

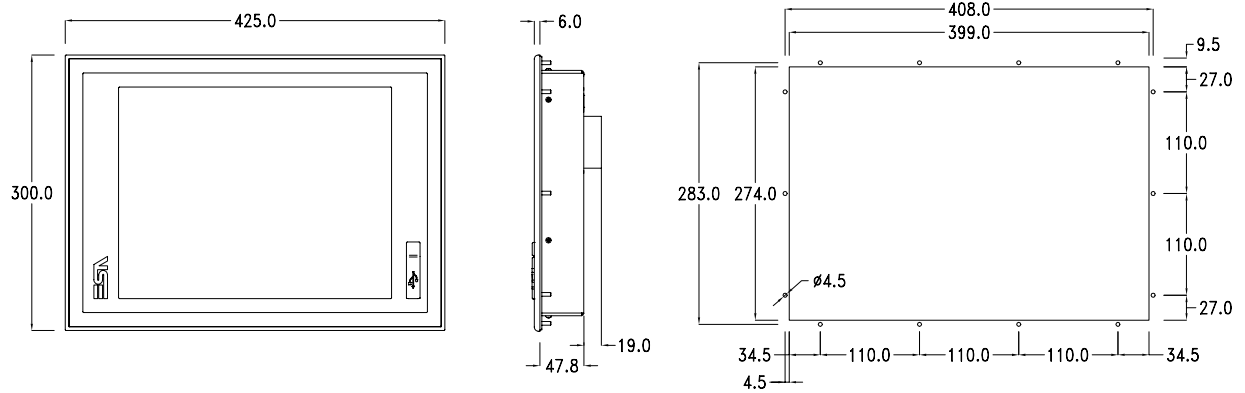

IT TERMINALI OPERATORE UNIVERSALI
IT UNIVERSAL OPERATOR TERMINALS
IT TERMINAUX OPERATEURS UNIVERSELS
IT UNIVERSELLE BEDIENTERMINALS
IT TERMINALES DE OPERADOR UNIVERSALES

**Dimensioni - Forature / Dimensions - Holes / Dimensions - Trous /
Abmessungen - Bohrungen / Dimensiones y perforaciones**

IT115



IT115

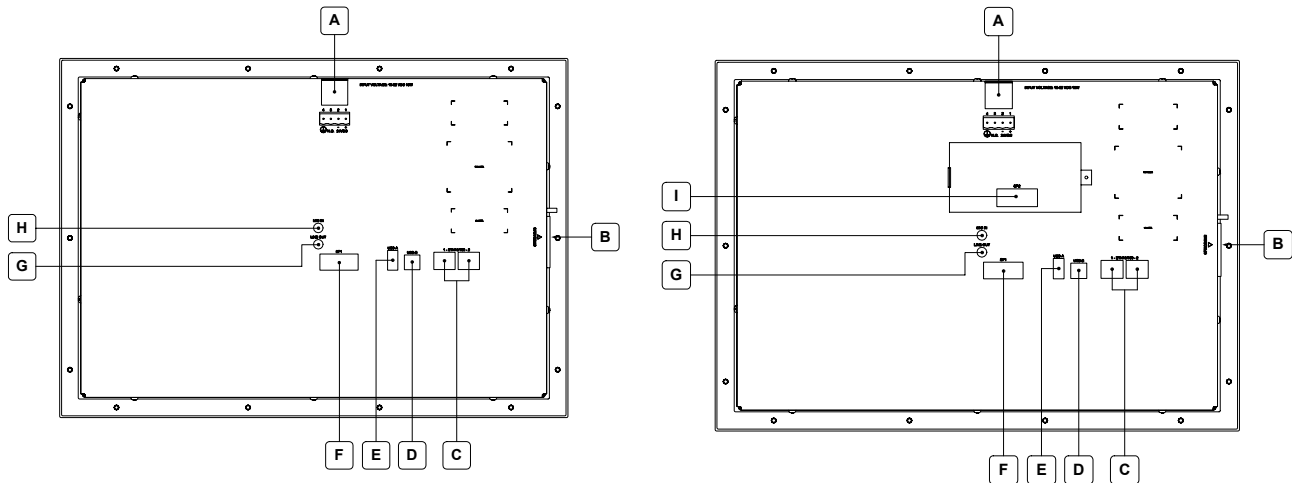

<p>A Connettore di alimentazione. Power supply connector. Connecteur d'alimentation. Anschluß für die Spannungsversorgung. Conector de alimentación.</p>	<p>F SP1 Porta seriale per la comunicazione con altri dispositivi. Serial port for communicating with other devices. Port sériel pour la communication avec autre dispositifs. Serielle Schnittstelle für die Kommunikation mit anderen Komponenten. Puerto serie para la comunicación con otros dispositivos.</p>
<p>B CF (Eject System) - SD/MMC (Push-Push System) Premere per inserire / Premere per estrarre Push-in / Push-out Pousser pour insérer / Pousser pour extraire Drücken - Karte einfügen / Drücken - Karte entnehmen Se inserta apretando / Se extrae apretando</p>	<p>G LINE OUT (Stereo - Jack 3,5mm) Presse per altoparlanti analogici alimentati o cuffie. Connection for powered analog loudspeakers or headphones. Connection pour haut-parleurs et écouteurs analogiques et alimentés. Anschluss für analoge Aktivboxen oder Kopfhörer. Toma para los altavoces analógicos alimentados o auriculares.</p>
<p>C 2 x ETH10/100 Ethernet 10/100 Mbit - Rj45 Ethernet 10/100 Mbit - Rj45 Ethernet 10/100 Mbit - Rj45 Ethernet 10/100 Mbit - Rj45 Ethernet 10/100 Mbit - Rj45</p>	<p>H MIC IN (Mono - Jack 3,5mm) Presse per microfono. Microphone connection. Connection microphone. Anschluss für Mikrofon. Toma para micrófono.</p>
<p>D USB-B Porta seriale per il trasferimento del progetto. Serial port to transfer the project. Port sériel pour le transfert du projet. USB-Schnittstelle für die Projektübertragung. Puerto serie para la transferencia del proyecto.</p>	<p>I SP2 (opzionale / optional / option / option / opción) Porta seriale per la comunicazione con altri dispositivi. Serial port for communicating with other devices. Port sériel pour la communication avec autre dispositifs. Serielle Schnittstelle für die Kommunikation mit anderen Komponenten. Puerto serie para la comunicación con otros dispositivos.</p>
<p>E USB-A Porta seriale USB. USB port. Port USB. USB-Schnittstelle. Puerto USB.</p>	

IT115

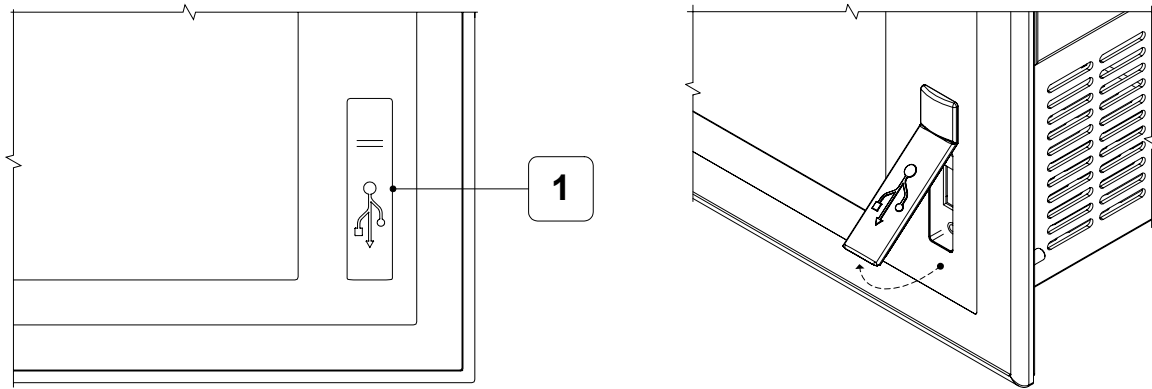

1	USB-A Porta Bus Seriale Universale Universal Serial Bus port Port Universal Serial Bus Universellen USB-Schnittstelle. Puerto Bus de Serie Universal
---	--

Alimentazione / Power supply / Alimentation / Spannungsversorgung / Alimentación

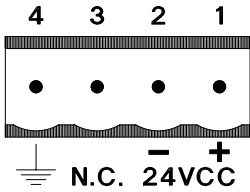

Power supply 4 pins connector	
1	+L 24 VDC
2	M 0 V
3	Not connected
4	PE Protective ground

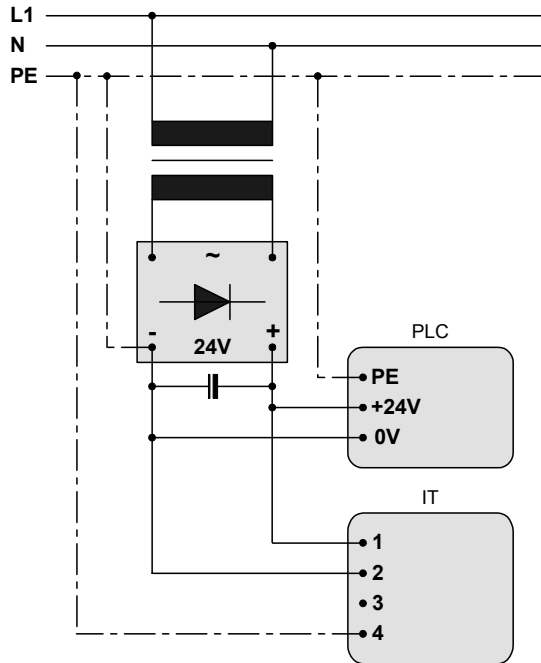

Attenzione: Queste due configurazioni danneggiano gravemente il IT.

Warning: These two configuration will seriously damage components.

Attention: Ces deux configurations peuvent endommager certains composants.

Warnung: Diese beiden Anschlussarten führen zu Schäden am IT Gerät.

Atención: Las dos configuraciones de arriba dañan gravemente el IT.

IMPORTANTE

La massa dei dispositivi collegati alle porte di comunicazione seriali e/o parallele deve essere tassativamente allo stesso potenziale dello 0V di alimentazione del IT. La circolazione di una corrente tra lo 0V di alimentazione e la massa delle porte di comunicazione potrebbe causare il danneggiamento di alcuni componenti del IT o dei dispositivi ad esso collegati.

IMPORTANT

The earth of the devices connected to the serial and/or parallel communication ports MUST have the same potential as the 0V supply of the IT. The circulation of current between the 0V supply and the earth of the communication ports could cause damage to certain components of the IT or of the devices connected to it.

IMPORTANT

La masse des dispositifs connectés aux portes de communication parallèles ou séries doit formellement être au même potentiel du 0V d'alimentation du IT. La circulation d'un courant entre le 0V d'alimentation et le masse des portes de communication pourrait causer des dommages aux composants du IT ou des dispositifs connectés.

WICHTIG

Die Erdung der Geräte, die über die parallelen und/oder seriellen Datenleitungen mit dem IT verbunden sind, muss das gleiche Potential haben wie die Erdung der Spannungsversorgung des Bedienterminals. Eine nicht korrekte Erdung der Spannungsversorgung und der Datenleitungen kann schwere Schäden an den Bediengeräten sowie an den angeschlossenen Komponenten hervorrufen.

ATENCIÓN

La masa de los dispositivos conectados en los puertos de comunicación serie y/o paralelo tiene que estar conectada imprescindiblemente al mismo potencial del 0V de alimentación del IT. La circulación de una corriente entre el 0V de alimentación y la masa de los puertos de comunicación podría causar daños a algunos componentes del IT o bien a algunos dispositivos conectados.

Temperatura di esercizio / Working temperature / Température d'exercice / Betriebstemperatur / Temperatura de servicio

Display / Display / Afficheur / Display / Pantalla: 0 / +50°C

Compatibilità elettromagnetica / Electromagnetic compatibility / Compatibilité électromagnétique / Elektromagnetische Verträglichkeit / Compatibilidad Electromagnética

Restrizioni d'uso: i requisiti di protezione non sono assicurati in zone residenziali / Restriction of use: the protection requirements is not ensured in residential areas / Restriction d'emploi: les protection n'est pas assurée dans les zones résidentielles / Nutzungsbeschränkung: den Schutzanforderungen in Wohngebieten nicht gewährleistet ist / Restricción de uso: los requisitos de protección no esté garantizado en zonas residenciales

**Porte di comunicazione / Communication ports / Portes de communication /
Kommunikations-Schnittstellen / Puertos de comunicación**

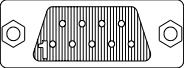
SP1	
	
Db 9 female connector	
1	Tx Rx485 +IN/OUT
2	RX1 IN
3	TX1 OUT
4	N.C.
5	Signal GND
6	Tx Rx485 -IN/OUT
7	RTS1 OUT
8	CTS1 IN
9	+ 3,3 VCC (reserved)

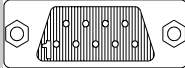
SP2	
	
Db 9 female connector	
1	Tx Rx485 +IN/OUT
2	RX1 IN
3	TX1 OUT
4	N.C.
5	Signal GND
6	Tx Rx485 -IN/OUT
7	RTS1 OUT
8	CTS1 IN
9	+ 3,3 VCC (reserved)

2 x ETH10/100	
	
RJ45 8 pin female connector	
1	TX+
2	TX-
3	RX+
4	N.C.
5	N.C.
6	RX-
7	N.C.
8	N.C.

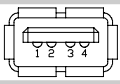
2 x USB-A	
	
4 pin male connector	
1	USBVCC (OUT)
2	USBD-
3	USBD+
4	Signal GND

USB-B	
	
4 pin male connector	
1	USBVCC (IN)
2	USBD-
3	USBD+
4	Signal GND

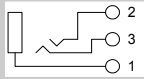
MIC IN	
	
3 pin female connector	
1	Signal GND
2	N.C.
3	Mic (IN)

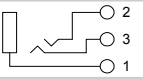
LINE OUT	
	
3 pin female connector	
1	Signal GND
2	Right (OUT)
3	Left (OUT)

N.C. : Not connected.



ESA elettronica S.p.A.
Via Padre Masciadri, 4/A
I - 22066 Mariano Comense (CO)
Tel. ++39-031757400 Fax ++39-031751777
web: <http://www.esahmi.com> e-mail: customer.care@esahmi.com