



YASKAWA

# YASKAWA AC Drive-V1000

## Compact Vector Control Drive

### Finless Type Installation Guide

Type CIMR-VA□□□□□□J□□  
CIMR-VA□□□□□□L□□

Models 200 V Class, Three-Phase Input: 0.1 to 18.5 kW  
200 V Class, Single-Phase Input: 0.1 to 3.0 kW  
400 V Class, Three-Phase Input: 0.2 to 18.5 kW

To properly use the product, read this manual thoroughly and retain for easy reference, inspection, and maintenance. Ensure the end user receives this manual.

## 安川インバータ V1000

小形ベクトル制御

### フィンレスタイプ 設置要領書

形 式 CIMR-VA□□□□□□J□□  
CIMR-VA□□□□□□L□□

容量範囲 200 V級(三相電源用)0.1~18.5 kW  
200 V級(单相電源用)0.1~3.0 kW  
400 V級(三相電源用)0.2~18.5 kW

製品を安全にお使い頂くために、この取扱説明書を必ずお読みください。  
また、本書をお手元に保管していただくとともに、最終的に本製品をご使用になるユーザー様のお手元に確実に届けられるよう、お取り計らい願います。

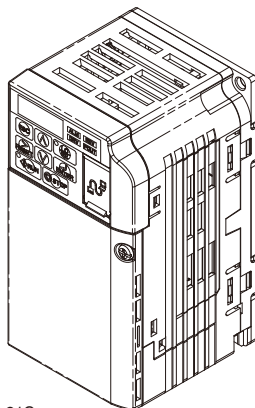

---

Copyright © 2007 YASKAWA ELECTRIC CORPORATION™

**All rights reserved. No part of this publication may be reproduced, stored in a retrieval system, or transmitted, in any form, or by any means, mechanical, electronic, photocopying, recording, or otherwise, without the prior written permission of Yaskawa. No patent liability is assumed with respect to the use of the information contained herein. Moreover, because Yaskawa is constantly striving to improve its high-quality products, the information contained in this manual is subject to change without notice. Every precaution has been taken in the preparation of this manual. Nevertheless, Yaskawa assumes no responsibility for errors or omissions. Neither is any liability assumed for damages resulting from the use of the information contained in this publication.**



# Table of Contents

---

<b>1 PREFACE</b> .....	<b>4</b>
<b>2 PRODUCT OVERVIEW</b> .....	<b>5</b>
<b>3 CONDITIONS OF ACCEPTABILITY</b> .....	<b>7</b>
<b>4 PERIODIC MAINTENANCE</b> .....	<b>14</b>
<b>5 DIMENSIONS</b> .....	<b>15</b>
<b>6 SELECTING AN EXTERNAL HEATSINK</b> .....	<b>20</b>
<b>7 REVISION HISTORY</b> .....	<b>24</b>

## 1 Preface

### ◆ Applicable Documentation

This manual provides instructions on installing the V1000 Finless drive. For more specific information on the operation of this product, refer to the other manuals listed in the following table:

	<b>Yaskawa AC Drive - V1000 Finless Installation Guide</b> <b>Manual No.: TOBPC71060621</b>
	This guide contains basic information required to install the V1000 Finless.
	<b>Yaskawa AC Drive - V1000 Technical Manual</b>
	This manual describes installation, wiring, operation procedures, functions, troubleshooting, maintenance, and inspections to perform before operation. To obtain instruction manuals for Yaskawa products access these sites: U.S.: <a href="http://www.yaskawa.com">http://www.yaskawa.com</a> Europe: <a href="http://www.yaskawa.eu.com">http://www.yaskawa.eu.com</a> Japan: <a href="http://www.e-mechatronics.com">http://www.e-mechatronics.com</a> Other areas: contact a Yaskawa representative.
	<b>Yaskawa AC Drive - V1000 Quick Start Guide</b>
This guide is packaged together with the product. It contains basic information required to install and wire the drive. This guide provides basic programming and simple setup and adjustment.	

### General Precautions

- The diagrams in this manual may be indicated without covers or safety shields to show details. Restore covers or shields before operating the drive and run the drive according to the instructions described in this manual.
- The products and specifications described in this manual or the content and presentation of the manual may be modified without notice to improve the product and/or the manual. Such modifications are indicated by a revised manual number.
- When ordering a new copy of the manual due to damage or loss, contact your Yaskawa representative or the nearest Yaskawa sales office and provide the manual number shown on the front cover.
- If nameplate becomes worn or damaged, order a replacement from your Yaskawa representative or the nearest Yaskawa sales office.
- Yaskawa is not responsible for any modification of the product by the end user. Modification of the product voids the warranty.

## 2 Product Overview

### ◆ About This Product

This manual describes installation conditions and dimensions for the V1000 Finless drive. Use this product only after you have a full understanding of the manual and its contents.

This V1000 Finless drive is a component recognized by Underwriters Laboratories Inc.(UL). The installation procedure and instructions have been provided to fulfill the requirements as specified by the “Conditions of Acceptability”.

### ◆ Model Number and Nameplate Check

Please perform the following tasks after receiving the drive:

- Inspect the drive for damage.
- If the drive appears damaged upon receipt, contact the shipper immediately.
- Verify receipt of the correct model by checking the information on the nameplate.
- If you have received the wrong model or the drive does not function properly, contact your supplier.

## 2 Product Overview

### ■ Nameplate

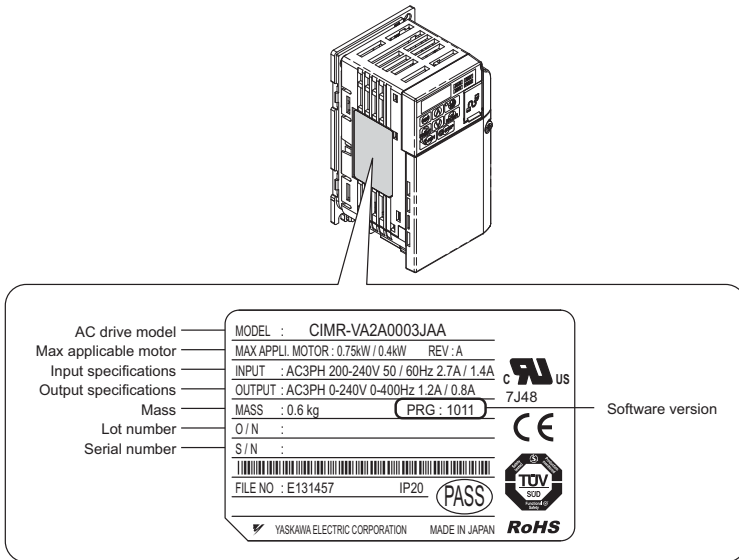

Figure 1 Nameplate Information

### ■ Drive Model Identification

The V1000 finless drive type is indicated by the letter “J” or “L” in the AC drive model designation code. Refer to the Quick Start Guide for complete model number information.

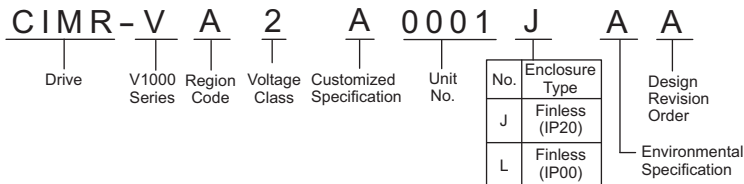

Figure 2 Understanding the Model Number

# 3 Conditions of Acceptability

Adhere to the installation conditions specified in this guide to take full advantage of the finless design of this drive.

### ◆ Ambient Temperature

The drive ambient temperature shall not exceed 50 °C (122 °F) for the drives installed location.

### ◆ Heatsink Plate Temperature

The aluminum panel on the back of the drive is referred to as the “heatsink plate.” The heatsink plate temperature should never exceed the following values:

CIMR-V□BA□□□□A, CIMR-V□2A0001~0020A, CIMR-V□4A0001~0011: 90 °C  
 CIMR-V□2A0030~0069A, CIMR-V□4A0018~0038: 80 °C

*Table 6* and *Table 7* lists the thermal characteristics of the drive.

Use parameter U4-08 to check the temperature of the heatsink plate as described below.

**NOTICE:** *The drive may be damaged if the temperature of the heatsink plate exceeds specified tolerance levels (90 °C or 80 °C, depending on the model). Excessive heat can also shorten the performance life of various drive components.*

### ■ Checking and Monitoring Heatsink Plate Temperature

#### Checking Heatsink Plate Temperature Using the LED Operator

Scroll to parameter U4-08 (heatsink plate temperature).

When the temperature of the heatsink plate is 89 °C, U4-08 will display:

00089

**Note:** Parameter U4-08 is available in drive software version 1011 or later.

#### Checking Heatsink Plate Temperature Using an Analog Output

**Example:** When using Multi-Function Analog Output Terminal AM, set the parameters shown in *Table 1*.

**Table 1 Using Analog Output 1**

No.	Name	Description
H4-01	Analog Output Terminal AM Function Selection	00408 (heatsink plate temperature)
H4-02	Analog Output Terminal AM Gain	100.0%
H4-03	Analog Output Terminal AM Bias	0.0%

### 3 Conditions of Acceptability

---

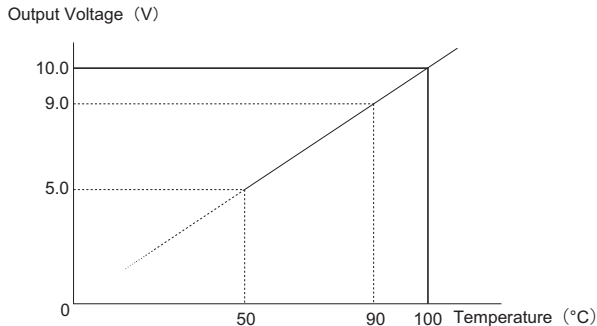

**Figure 3 Output of Heatsink Plate Temperature by Analog Output**

- Note:**
1. Accuracy of the temperature reading may vary  $\pm 5^\circ\text{C}$  between 50 and 100  $^\circ\text{C}$ .
  2. The heatsink temperature is affected by the ambient temperature. Never exceed the allowable maximum heatsink plate temperature.

#### ■ Drive Overheat Alarm (oH)

Use parameter L8-02 to cause the drive output an alarm when the heatsink plate exceeds the specified temperature.

L8-03 determines the action taken by the drive when an oH alarm is triggered. Refer to the V1000 Technical Manual for more details.

---

#### ◆ Installation to Metallic Surface

The mating surface shall have the following properties:

- Surface flatness shall not exceed 0.2 mm across the entire mating surface.
- Surface roughness shall not exceed 25 S.

**Note:** A surface roughness of 25 S means “Ra” (average roughness) is not greater than 6.3 and “Ry” (maximum peak) is not greater than 25  $\mu\text{m}$ .

---

#### ◆ Thermal Compound

Apply a thermal compound between the heatsink plate and the mating surface. The thermal compound assists in drive heat dissipation.

Yaskawa recommends the thermal compounds in [Table 2](#).



**Table 2 Recommended Heatsink Plate Thermal Compounds**

Manufacturer	Type	Model	Recommended spread amount
Shin-Etsu Chemical Inc.	Oil-based compound	G746	100 μm Apply the coating evenly across the surface
Dow Corning Toray Inc.	Silicone compound for heat dissipation	SC4471CV	

When applying the thermal compound, spread it over the surface of the heatsink plate. After mounting the heatsink plate to the metal back panel, wipe away any excess compound from around the heatsink plate.

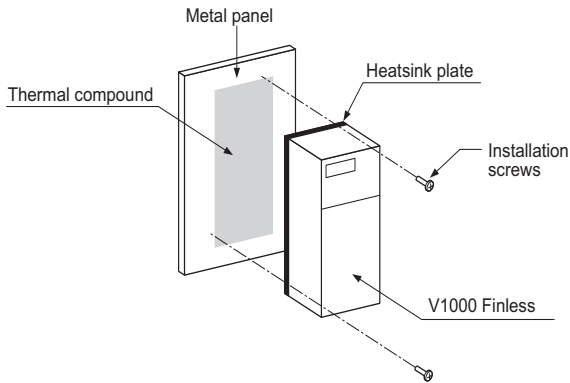

**Figure 4 Application of Thermal Compound**

#### ◆ Drive Heatsink Plate Installation Screw Size and Tightening Torque

Screw size and torque specifications for heatsink plate installation screws that hold the drive to a metal back panel are listed in [Table 3](#).

**Table 3 Screw Size and Tightening Torque**

Voltage Class	Model CIMR-V□	Screw Size	Tightening Torque N • m (ft-lbf)
Single-Phase 200 V class	BA0001 ~ BA0012	M4	1.0 to 1.3 (0.74 to 0.96)
	2A0001 ~ 2A0020	M4	1.0 to 1.3 (0.74 to 0.96)
Three-phase 200V class	2A0030 ~ 2A0056	M5	2.0 to 2.5 (1.48 to 1.84)
	2A0069	M6	4.0 to 5.0 (2.95 to 3.69)

### 3 Conditions of Acceptability

Voltage Class	Model CIMR-V□	Screw Size	Tightening Torque N • m (ft-lbf)
Three-phase 400V class	4A0001 ~ 4A0011	M4	1.0 to 1.3 (0.74 to 0.96)
	4A0018 ~ 4A0038	M5	2.0 to 2.5 (1.48 to 1.84)

**NOTICE:** Tighten all screws according to specified torques. Failure to do so may inhibit drive cooling and possible damage the drive.

#### ◆ Installation Spacing

*Figure 5* illustrates correct installation spacing for proper airflow, and wiring. The drive should be installed so that the heatsink plate rests flat against the metal back panel to ensure proper cooling.

**Table 4 Correct Installation Spacing**

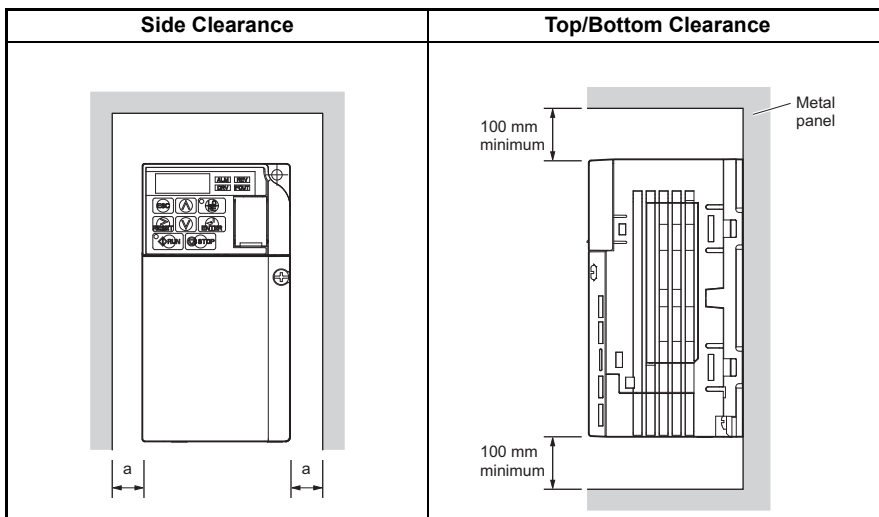

**Table 5 Correct Installation Spacing**

Voltage Class	Drive Model CIMR-V□	Side Clearance (a) mm / (in)
Single-Phase 200 V Class	BA0001 to BA0012	30 / (1.18)
Three-Phase 200 V Class	2A0001 to 2A0069	
Three-Phase 400 V Class	4A0001 to 4A0038	

### 3 Conditions of Acceptability

**NOTICE:** Do not install V1000 Finless drives using the Side-by-Side method available in standard V1000 drive models. Improper drive cooling may result in damage to the drive. Install V1000 Finless drives with a minimum side-by-side clearance of 30 mm (1.18 in).

#### ■ Ambient Temperature Derating

Parameters L8-12 (Ambient Temperature Setting) and L8-35 (Installation Method Selection) must be set according to the installation conditions if the ambient temperature is higher than 35°C. Refer to [Figure 5](#) for drive derating according to ambient temperature.

Parameter L8-12 = 40°C (default). The setting range is -10 to 50°C.

Operating the V1000 Finless drive between -10 and 35 °C allows 100% continuous current without derating. Drive operation between 35 and 50 °C requires drive derating according to [Figure 5](#).

The drive can be used with 100% rating between -10 and 50°C ambient temperature if the airflow around the unit is 0.5 m/s or more. In this case set L8-35 = 0 (Installation method = IP20 standard drive).

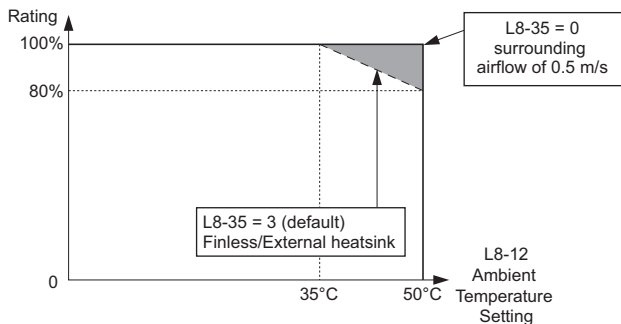

Figure 5 Ambient Temperature and Drive Derating

### 3 Conditions of Acceptability

#### ◆ V1000 Finless Drive Watt Loss Thermal Characteristics

##### ■ Normal Duty

Table 6 Drive Watt Loss (Normal Duty Rating)

200 V Single-Phase Class														
Model CIMR-V□BA		0001	0002	0003	0006	–	0010	0012	–	–	–	–	–	
Rated Output Current (A)		1.2	1.9	3.3	6.0	–	9.6	12.0	–	–	–	–	–	
Generated Heat Loss	Heatsink Plate (W)	5.0	7.6	14.6	30.1	–	51.7	61.3	–	–	–	–	–	
	Internal (W)	8.0	9.7	14.4	19.4	–	29.8	37.1	–	–	–	–	–	
	Total (W)	13.5	17.3	29.0	49.5	–	81.5	98.4	–	–	–	–	–	
200 V Three-Phase Class														
Model CIMR-V□2A		0001	0002	0004	0006	0008	0010	0012	0018	0020	0030	0040	0056	0069
Rated Output Current (A)		1.2	1.9	3.5	6.0	8.0	9.6	12.0	17.5	19.6	30.0	40.0	56.0	69.0
Generated Heat Loss	Heatsink Plate (W)	5.0	7.6	15.8	27.5	44.6	51.7	61.3	89.8	98.7	238.2	266.7	357.9	477.3
	Internal (W)	8.0	9.5	13.6	17.2	24.0	25.8	30.4	44.1	46.3	85.8	108.6	145.2	185.8
	Total (W)	13.0	17.1	29.4	44.7	68.6	77.5	91.7	133.9	145.0	324.0	375.3	503.1	663.1
400 V Three-Phase Class														
Model CIMR-V□4A		0001	0002	0004	0005	–	0007	0009	–	0011	0018	0023	0031	0038
Rated Output Current (A)		1.2	2.1	4.1	5.4	–	6.9	8.8	–	11.1	17.5	23.0	31.0	38.0
Generated Heat Loss	Heatsink Plate (W)	10.0	18.5	30.5	44.5	–	58.5	63.7	–	81.7	181.2	213.4	287.5	319.2
	Internal (W)	9.6	13.9	16.8	21.8	–	28.5	31.4	–	46.0	78.4	101.8	139.4	138.8
	Total (W)	19.6	32.4	47.3	66.3	–	87.0	95.1	–	127.7	259.6	315.2	426.9	458.0

Note: Carrier frequency is set to 2 kHz.

#### ■ Heavy Duty

**Table 7 Drive Watt Loss (Heavy Duty Rating)**

200 V Single-Phase Class														
Model CIMR-V□BA		0001 <>	0002 <>	0003 <>	0006 <>	–	0010 <>	0012 <>	–	–	–	–	–	
Rated Output Current (A)		0.8	1.6	3.0	5.0	–	8.0	11.0	–	–	–	–	–	
Generated Heat Loss	Heatsink Plate (W)	4.3	7.9	16.1	33.7	–	54.8	70.7	–	–	–	–	–	
	Internal (W)	7.4	8.9	11.5	16.8	–	25.9	34.1	–	–	–	–	–	
	Total (W)	11.7	16.8	27.6	50.5	–	80.7	104.8	–	–	–	–	–	
200 V Three-Phase Class														
Model CIMR-V□2A		0001 <>	0002 <>	0004 <>	0006 <>	0008 <>	0010 <>	0012 <>	0018 <>	0020 <>	0030 <>	0040 <>	0056 <>	0069 <>
Rated Output Current (A)		0.8	1.6	3.0	5.0	6.9	8.0	11.0	14.0	17.5	25.0	33.0	47.0	60.0
Generated Heat Loss	Heatsink Plate (W)	4.3	7.9	16.1	27.4	48.7	54.8	70.7	92.6	110.5	213.3	239.5	347.6	473.9
	Internal (W)	7.3	8.8	11.5	15.9	22.2	23.8	30.0	38.8	43.3	68.1	79.6	113.8	156.7
	Total (W)	11.6	16.7	27.6	43.3	70.9	78.6	100.7	131.4	153.8	281.4	319.1	461.4	630.6
400 V Three-Phase Class														
Model CIMR-V□4A		0001 <>	0002 <>	0004 <>	0005 <>	–	0007 <>	0009 <>	–	0011 <>	0018 <>	0023 <>	0031 <>	0038 <>
Rated Output Current (A)		1.2	1.8	3.4	4.8	–	5.5	7.2	–	9.2	14.8	18.0	24.0	31.0
Generated Heat Loss	Heatsink Plate (W)	19.2	28.9	42.3	70.7	–	81.0	84.6	–	107.2	166.0	207.1	266.9	319.1
	Internal (W)	11.4	14.9	17.9	26.2	–	30.7	32.9	–	41.5	61.7	75.0	102.1	115.4
	Total (W)	30.6	43.8	60.2	96.9	–	111.7	117.5	–	148.7	227.7	282.1	369.0	434.5

<1> Carrier frequency is set to 10 kHz.

<2> Carrier frequency is set to 8 kHz.

# 4 Periodic Maintenance

---

### ◆ Replacement

Estimated drive performance life is based on specific usage conditions. These conditions are provided for the purpose of maximizing useful drive life and performance. Drive performance and/or useful life are affected by application in harsh environments or rigorous use.

### ■ Conditions for Estimating Performance Life

The estimated performance life of the drive is 10 years under the following conditions:

- Drive ambient temperature: Yearly average of 35°C
- Load factor: 80% max.
- Operation time: 24 hours a day

Drive performance life may be less than 10 years if drive use exceeds the conditions above.

# 5 Dimensions

**Table 8 V1000 Finless Dimensions for Models BA0001~2A0006 (metric)**

Voltage Class	Drive Model CIMR-V□	Dimensions (mm)							Weight (kg)
		W	H	D	W1	H1	H2	t1	
Single-Phase 200 V class	BA0001	68	128	71	56	118	5	3	0.6
	BA0002	68	128	71	56	118	5	3	0.6
	BA0003	68	128	81	56	118	5	3	0.8
Three-Phase 200 V class	2A0001	68	128	71	56	118	5	3	0.6
	2A0002	68	128	71	56	118	5	3	0.6
	2A0004	68	128	71	56	118	5	3	0.7
	2A0006	68	128	71	56	118	5	3	0.7

**Table 9 V1000 Finless Dimensions for Models BA0001~2A0006 (U.S. units)**

Voltage Class	Drive Model CIMR-V□	Dimensions (in)							Weight (lb.)
		W	H	D	W1	H1	H2	t1	
Single-Phase 200 V class	BA0001	2.68	5.04	2.80	2.21	4.65	0.20	0.12	1.32
	BA0002	2.68	5.04	2.80	2.21	4.65	0.20	0.12	1.32
	BA0003	2.68	5.04	3.19	2.21	4.65	0.20	0.12	1.76
Three-Phase 200 V class	2A0001	2.68	5.04	2.80	2.21	4.65	0.20	0.12	1.32
	2A0002	2.68	5.04	2.80	2.21	4.65	0.20	0.12	1.32
	2A0004	2.68	5.04	2.80	2.21	4.65	0.20	0.12	1.54
	2A0006	2.68	5.04	2.80	2.21	4.65	0.20	0.12	1.54

## 5 Dimensions

Table 10 V1000 Finless Dimensions for Models BA0006~4A0009 (metric)

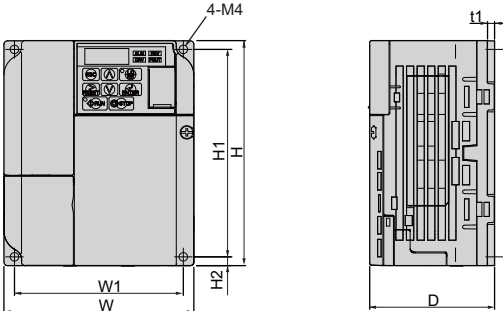

Voltage Class	Drive Model CIMR-V□	Dimensions (mm)							
		W	H	D	W1	H1	H2	t1	Weight (kg)
Single-Phase 200 V class	BA0006	108	128	79.5	96	118	5	4	1.1
	BA0010	108	128	91	96	118	5	4	1.1
Three-Phase 200 V class	2A0008	108	128	71	96	118	5	4	1.0
	2A0010	108	128	71	96	118	5	4	1.0
	2A0012	108	128	79.5	96	118	5	4	1.0
Three-Phase 400 V class	4A0001	108	128	71	96	118	5	4	0.9
	4A0002	108	128	71	96	118	5	4	0.9
	4A0004	108	128	79.5	96	118	5	4	1.0
	4A0005	108	128	96	96	118	5	4	1.0
	4A0007	108	128	96	96	118	5	4	1.1
	4A0009	108	128	96	96	118	5	4	1.1



**Table 11 V1000 Finless Dimensions for Models BA0006~4A0009 (U.S. units)**

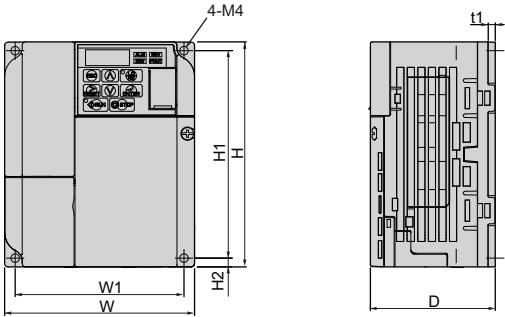

Voltage Class	Drive Model CIMR-V□	Dimensions (in)							
		W	H	D	W1	H1	H2	t1	Weight (lb.)
Single-Phase 200 V class	BA0006	4.26	5.04	3.13	3.78	4.65	0.20	0.16	2.43
	BA0010	4.26	5.04	3.59	3.78	4.65	0.20	0.16	2.43
Three-Phase 200 V class	2A0008	4.26	5.04	2.80	3.78	4.65	0.20	0.16	2.20
	2A0010	4.26	5.04	2.80	3.78	4.65	0.20	0.16	2.20
	2A0012	4.26	5.04	3.13	3.78	4.65	0.20	0.16	2.20
Three-Phase 400 V class	4A0001	4.26	5.04	2.80	3.78	4.65	0.20	0.16	1.98
	4A0002	4.26	5.04	2.80	3.78	4.65	0.20	0.16	1.98
	4A0004	4.26	5.04	3.13	3.78	4.65	0.20	0.16	2.20
	4A0005	4.26	5.04	3.78	3.78	4.65	0.20	0.16	2.20
	4A0007	4.26	5.04	3.78	3.78	4.65	0.20	0.16	2.43
	4A0009	4.26	5.04	3.78	3.78	4.65	0.20	0.16	2.43

## 5 Dimensions

Table 12 V1000 Finless Dimensions for Models BA0012~4A0011(metric)

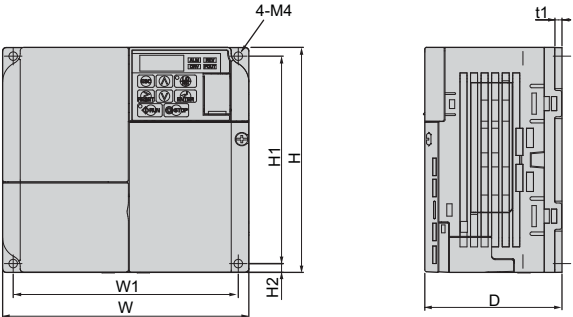

Voltage Class	Drive Model CIMR-V□	Dimensions (mm)							
		W	H	D	W1	H1	H2	t1	Weight (kg)
Single-Phase 200 V class	BA0012	140	128	98	128	118	5	4	1.4
Three-Phase 200 V class	2A0018	140	128	78	128	118	5	4	1.3
	2A0020	140	128	78	128	118	5	4	1.3
Three-Phase 400 V class	4A0011	140	128	78	128	118	5	4	1.3

Table 13 V1000 Finless Dimensions for Models BA0012~4A0011 (U.S. units)

Voltage Class	Drive Model CIMR-V□	Dimensions (in)							
		W	H	D	W1	H1	H2	t1	Weight (lb.)
Single-Phase 200 V class	BA0012	5.52	5.04	3.86	5.04	4.65	0.20	0.16	3.09
Three-Phase 200 V class	2A0018	5.52	5.04	3.07	5.04	4.65	0.20	0.16	2.87
	2A0020	5.52	5.04	3.07	5.04	4.65	0.20	0.16	2.87
Three-Phase 400 V class	4A0011	5.52	5.04	3.07	5.04	4.65	0.20	0.16	2.87

**Table 14 V1000 Finless Dimensions for Models 2A0030~4A0038 (metric)**

Voltage Class	Drive Model CIMR-V□	Dimensions (mm)											
		W	H	D	W1	H1	H2	H3	H4	H5	d	t1	Weight (kg)
Three-Phase 200 V class	2A0030	140	260	145	122	248	6	234	13	5	M5	5	3.2
	2A0040	140	260	145	122	248	6	234	13	5	M5	5	3.2
	2A0056	180	300	147	160	284	8	270	15	5	M5	5	4.6
	2A0069	220	350	152	192	336	7	320	15	5	M6	5	7.0
Three-Phase 400 V class	4A0018	140	260	145	122	248	6	234	13	5	M5	5	3.1
	4A0023	140	260	145	122	248	6	234	13	5	M5	5	3.2
	4A0031	180	300	147	160	284	8	270	15	5	M5	5	4.3
	4A0038	180	300	147	160	284	8	270	15	5	M5	5	4.6

**Table 15 V1000 Finless Dimensions for Models 2A0030~4A0038 (U.S. units)**

Voltage Class	Drive Model CIMR-V□	Dimensions (in)											
		W	H	D	W1	H1	H2	H3	H4	H5	d	t1	Weight (lb.)
Three-Phase 200 V class	2A0030	5.51	10.24	5.71	4.81	9.77	0.24	9.22	0.51	0.20	M5	0.20	7.06
	2A0040	5.51	10.24	5.71	4.81	9.77	0.24	9.22	0.51	0.20	M5	0.20	7.06
	2A0056	7.09	11.82	5.79	6.30	11.19	0.36	10.64	0.59	0.20	M5	0.20	10.14
	2A0069	8.69	13.79	5.99	7.56	13.24	0.28	12.61	0.59	0.20	M6	0.20	15.43
Three-Phase 400 V class	4A0018	5.51	10.24	5.71	4.81	9.77	0.24	9.22	0.51	0.20	M5	0.20	6.83
	4A0023	5.51	10.24	5.71	4.81	9.77	0.24	9.22	0.51	0.20	M5	0.20	7.06
	4A0031	7.09	11.82	5.79	6.30	11.19	0.36	10.64	0.59	0.20	M5	0.20	9.48
	4A0038	7.09	11.82	5.79	6.30	11.19	0.36	10.64	0.59	0.20	M5	0.20	10.14

## 6 Selecting an External Heatsink

# 6 Selecting an External Heatsink

This section describes the selection of a suitable external heatsink when using a V1000 Finless drive.

### ◆ Data Required for Heatsink Selection

The table below shows data that are needed to select a heatsink that suits drive and application.

Symbol	Description
$P_{Loss}$	Drive heat loss <i>Refer to V1000 Finless Drive Watt Loss Thermal Characteristics on page 12</i> to check the amount of heat loss from the heatsink plate of the drive.
$T_{HSP\_max}$	Maximum heatsink plate temperature This is the temperature at the surface of the heatsink plate. It can be monitored with U4-08. The maximum allowable value depends on drive model. CIMR-V□BA□□□□A, CIMR-V□2A0001~0020A, CIMR-V□4A0001~0011: 90 °C CIMR-V□2A0030~0069A, CIMR-V□4A0018~0038: 80 °C
$T_{Amb}$	External heatsink ambient temperature (air temperature around heatsink)
$R\theta_{HSP}$	Heatsink plate thermal resistance This value is 0.05 K/W
$R\theta_{HSP-EHS}$	Thermal resistance between the heatsink plate and the external heatsink Can be calculated by $R\theta_{HSP-EHS} = \frac{d_{Comp}}{\lambda_{comp} \cdot A_{th}}$
	$A_{th}$ Heat transfer area between drive heatsink plate and external heatsink Note: Due to uneven heat generation across the heatsink plate (by arrangement of internal components) the effective area for heat transfer is only ~70% of heatsink plate area. This must be considered when calculating the thermal resistance. Refer to <i>Dimensions on page 15</i> for values of H and W to calculate the area of the heatsink plate.
	$\lambda_{Comp}$ Thermal conductivity of the heatsink thermal compound
	$d_{Comp}$ Thickness of the thermal compound
$R\theta_{EHS}$	Thermal resistance of the external heatsink

### ◆ External Heatsink Selection

**Figure 6** shows the heat transfer principle from the drive heatsink plate to the heatsink ambient air.

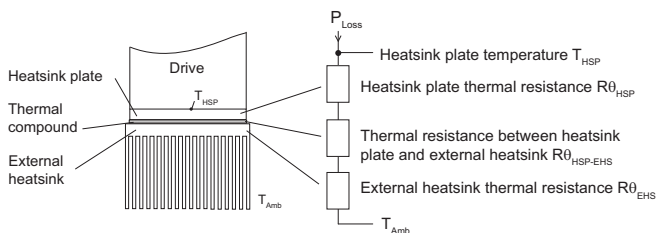

**Figure 6 Thermal Equivalent Circuit**

For a given ambient temperature the heatsink plate temperature must not exceed the maximum allowable value. As the  $R\theta_{HSP}$  and  $R\theta_{HSP-EHS}$  are essentially fixed, this condition must be satisfied with proper heatsink selection.

#### ■ Select an External Heatsink by the Thermal Resistance

Use the formula below to calculate the maximum thermal resistance  $R\theta_{EHS\_max}$ .

$$R\theta_{EHS\_max} = \left( \frac{T_{HSP\_max} - T_{Amb}}{P_{Loss}} - R\theta_{HSP} - R\theta_{HSP-EHS} \right)$$

Select a heatsink with a smaller thermal resistance than  $R\theta_{EHS\_max}$ . The heatsink height and width should be close to the drive dimensions. If the selected heatsink has a thermal resistance that is too high, then choose a heatsink with a different shape (e.g. longer or more fins). Compare the actual mounting conditions with the ones mentioned for the  $R\theta_{EHS}$  value in the heatsink specifications and apply reduction factors if necessary. Also remember that the heatsink cooling ability can reduce by time due to dirt.

**NOTICE:** If the heatsink height and width are much larger than the drive heatsink plate dimensions or if multiple drives are installed on one heatsink, it may be necessary to apply correction factors to the thermal resistance value given in the heatsink specification. Consult the heatsink manufacturer.

#### ■ Check the Feasibility of a Given Heatsink

If a heatsink is given or the selection is limited by the installation conditions (space available etc.) use the formula below to calculate the actual heatsink plate temperature.

$$T_{HSP} = P_{Loss} \cdot (R\theta_{HSP} + R\theta_{HSP-EHS} + R\theta_{EHS}) + T_{Amb}$$

If  $T_{HSP}$  is smaller than the maximum allowable heatsink plate temperature, the selected heatsink can be used. For verification of temperature, refer to [Checking and Monitoring Heatsink Plate Temperature on page 7](#).

## 6 Selecting an External Heatsink

**NOTICE:** Due to uneven compound thickness, uneven heat generation across the heatsink plate or other factors, the actual heatsink plate temperature (monitored in U4-08) can be slightly different from the calculated value. An oH drive fault may occur if the heatsink plate temperature exceeds the maximum allowable value.

### ◆ Heatsink Selection Example

This example shows heatsink selection for a CIMR-V□2A0006 drive in Normal Duty (ND) mode. The data required are listed in the table below.

Item	Value
$P_{Loss}$	27.5 W
$T_{HSP\_max}$	90°C
$T_{Amb}$	40°C
$R\theta_{HSP}$	0.05 K/W
$R\theta_{HSP\_EHS}$	$A_{th}$ $H = 128 \text{ mm}, D = 68 \text{ mm},$ $A_{th} = 0.7 \cdot 0.128 \text{ m} \cdot 0.068 \text{ m} = 6.1 \cdot 10^{-3} \text{ m}^2$
	$\lambda_{Comp}$ Thermal conductivity of “Thermal Compound G746” (Shin-Etsu Chemical Co., Ltd)
	$d_{Comp}$ Recommended compound thickness: 100 $\mu\text{m}$
	$R\theta_{HSP\_EHS} = \frac{100 \mu\text{m}}{0.8 \text{ W}/(\text{m}\cdot\text{K}) \times 6.1 \times 10^{-3} \text{ m}^2} = 0.02 \text{ K/W}$

### ■ Heatsink Selection by Thermal Resistance

Substituting the example values into the formula gives:

$$R\theta_{\text{EHS,max}} = \left( \frac{90\text{ }^{\circ}\text{C} - 40\text{ }^{\circ}\text{C}}{27.5\text{ W}} - 0.05\text{ K/W} - 0.02\text{ K/W} \right) = 1.74\text{ K/W}$$

The heatsink must have a thermal resistance lower than 1.7 K/W. When selecting the heatsink apply a safety margin to the calculated value in order to ensure tripless drive operation, even if the installation conditions change (temporary higher temperature, loss of cooling ability of the external heatsink due to dust, etc.).

### ■ Feasibility Check of a Selected Heatsink

If for example a heatsink with  $R\theta_{\text{EHS}} = 1.6\text{ K/W}$  is selected, the heatsink temperature will be:

$$T_{\text{HSP}} = 27.5\text{ W} \cdot (0.05\text{ K/W} + 0.02\text{ K/W} + 1.6\text{ K/W}) + 40\text{ }^{\circ}\text{C} = 85.9\text{ }^{\circ}\text{C}$$

The selected heatsink can be used, but considering that the heatsink area is probably larger than the drive footprint and the ambient conditions could change (reduced heatsink cooling ability by dirt, etc.), a heatsink with a lower  $R\theta_{\text{EHS}}$  (e.g.  $R\theta_{\text{EHS}} = 1.1\text{ K/W}$ , resulting in  $T_{\text{HSP}} = 72.2\text{ }^{\circ}\text{C}$ ) should be chosen.

## 7 Revision History

# 7 Revision History

Document numbers and revision dates are provided on the bottom of the back cover of the manual.

MANUAL NO. TOBP C710606 21B

Published in Japan July 2007 07-4 ◇

└─ Date of publication ─┬─ Revision number  
└─ Date of original publication ─┘

Date of Publication	Rev. No.	Section	Revised Content
April 2007	–	–	First edition
July 2007	◇	Chapter 2	Addition: Checking the Temperature of Heatsink Plate of Drive (software version 1011 or later)
		Chapter 4	Addition: Selecting an External Heatsink
March 2008	◇	All Chapters	New: Protective enclosure data (IP00) New models: 3-phase 200 V: CIMR-V□2A0030 - 2A0069 3-phase 400 V: CIMR-V□4A0018 - 4A0038
		Chapter 2	Corrections: Settings for H4-01 in Table 1. New: Warning for the heatsink plate temperature Overheat prealarm
		Chapter 3	New: Maintenance information
		Chapter 6	Revision: Selecting an External Heatsink



# YASKAWA AC Drive -V1000

## Compact Vector Control Drive

## Finless Type Installation Guide

---

### **IRUMA BUSINESS CENTER (SOLUTION CENTER)**

480, KamifujiSawa, Iruma, Saitama 358-8555, Japan  
Phone 81-4-2962-5696 Fax 81-4-2962-6138

### **YASKAWA ELECTRIC AMERICA, INC.**

2121 Norman Drive South, Waukegan, IL 60085, U.S.A.  
Phone 1-847-887-7000 Fax 1-847-887-7370

### **YASKAWA ELÉTRICO DO BRASIL LTDA.**

Avenida Fagundes Filho, 620 São Paulo-SP CEP 04304-000, Brazil  
Phone 55-11-3585-1100 Fax 55-11-5581-8795

### **YASKAWA ELECTRIC EUROPE GmbH**

Am Kronberger Hang 2, 65824 Schwalbach, Germany  
Phone 49-6196-569-300 Fax 49-6196-569-312

### **YASKAWA ELECTRIC UK LTD.**

1 Hunt Hill Orchardton Woods Cumbernauld, G68 9LF, United Kingdom  
Phone 44-1236-735000 Fax 44-1236-458182

### **YASKAWA ELECTRIC KOREA CORPORATION**

7F, Doore Bldg. 24, Yeoido-dong, Youngdungpo-Ku, Seoul 150-877, Korea  
Phone 82-2-784-7844 Fax 82-2-784-8495

### **YASKAWA ELECTRIC (SINGAPORE) PTE. LTD.**

151 Lorong Chuan, #04-01, New Tech Park 556741, Singapore  
Phone 65-6282-3003 Fax 65-6289-3003

### **YASKAWA ELECTRIC (SHANGHAI) CO., LTD.**

No.18 Xizang Zhong Road, Room 1702-1707, Harbour Ring Plaza Shanghai 200001, China  
Phone 86-21-5385-2200 Fax 86-21-5385-3299

### **YASKAWA ELECTRIC (SHANGHAI) CO., LTD. BEIJING OFFICE**

Room 1011A, Tower W3 Oriental Plaza, No.1 East Chang An Ave.,  
Dong Cheng District, Beijing 100738, China  
Phone 86-10-8518-4086 Fax 86-10-8518-4082

### **YASKAWA ELECTRIC TAIWAN CORPORATION**

9F, 16, Nanking E. Rd., Sec. 3, Taipei, Taiwan  
Phone 886-2-2502-5003 Fax 886-2-2505-1280



YASKAWA

YASKAWA ELECTRIC CORPORATION

In the event that the end user of this product is to be the military and said product is to be employed in any weapons systems or the manufacture thereof, the export will fall under the relevant regulations as stipulated in the Foreign Exchange and Foreign Trade Regulations. Therefore, be sure to follow all procedures and submit all relevant documentation according to any and all rules, regulations and laws that may apply. Specifications are subject to change without notice for ongoing product modifications and improvements.

© 2007-2008 YASKAWA ELECTRIC CORPORATION. All rights reserved.

MANUAL NO. TOBP C710606 21C

Published in Japan March 2008 07-4 -0  
07-11-2