

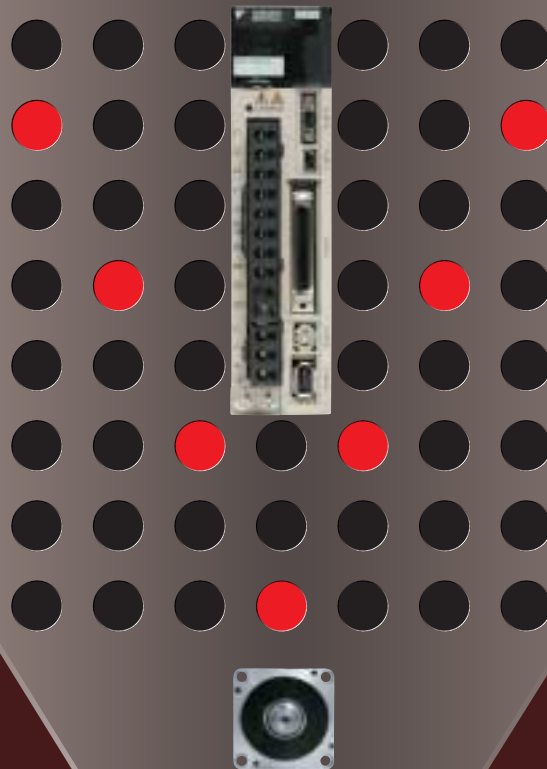

YASKAWA

AC SERVO DRIVES Σ -V SERIES PRODUCT CATALOG

Field-Proven Performance:
A Servo that Does What You Need!



Certified for
ISO9001 and
ISO14001



JQA-0422

JQA-EM0202

JQA-EM0924

Build the machine you've dreamed of, today!

AC servo drive
Sigma Five

Σ -V

You want maximum effect quickly and easily, as does every engineer in the field. And now the Σ -V series is here with the practical answer to your dreams!

How many times have you heard people say servos need adjustment to work well? Our new tuning-less function means it works as soon as you hook it up!

And if you want more performance than ever before, the Σ -V series advanced autotuning function lets you set up for it rapidly.

Advanced technology makes possible a host of safety standards compliance for the first time in Japan (as of April 2007), compliance with key international standards, a diverse motor line-up, compact size, high speed and simple maintenance: everything you need to answer today's requirements.

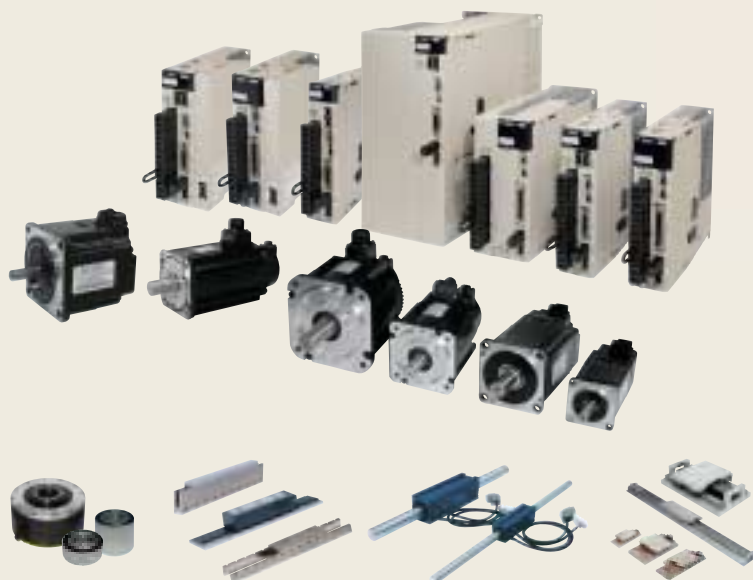

International Standards



Safety Standards

Safety Stop-0 (Standard)

RoHS Directive

RoHS Directive Stands for the EU directive on the Restriction of the Use of Certain Hazardous Substances in Electrical and Electronic Equipment.

Features

Superlative Performance

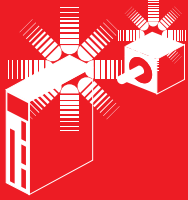

Operate your machinery faster and with higher precision than ever!

The Σ -V delivers the highest performance in the industry.

- The best **amplifier** response in the industry slashes settling time

In-house comparison: 1/12th

Outstanding frequency response
1.6 kHz*



*: Representative value when using a combination of the SGMJV-02ADA servomotor and SGD1V-1R6A SERVOPACK at one time of the load moment of inertia ratio.

● Servo Adjustment Example: When the ball screw slider was run using a combination of the SGMJV-02ADA servomotor and SGD1V-1R6A SERVOPACK.

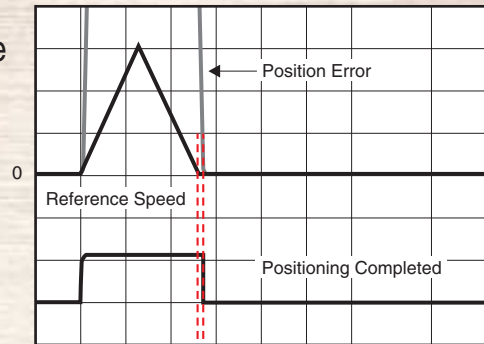

Settling Time 0 to 4 ms!

- Enhanced vibration suppression

Existing functions to minimize vibration have been enhanced, and new ones added, improving tracking and further improving settling time. Vibration and noise during driving have also been cut, along with vibration at machine edges when stopping.

- Contributing to machine performance in conjunction with a medium-inertia motor

Small Capacity
SGMJV Series



Low Heating

Improved motor constants have reduced both losses and heating.

Better Tact Time

Instantaneous peak torque has been boosted from 300% to 350%, contributing to shorter tact times

Ease of Use

Moment of inertia ratio has been doubled in the same motor, reducing the moment of inertia ratio and boosting gain for faster settling

Medium Capacity
SGMGV Series



Compact Design

Smaller package and about 20% lighter, but with the same moment of inertia ratio as the conventional model. A small encoder connector is applied.

Improved Vibration Resistance

New coupling delivers typical 5G vibration resistance

Encoder resolution
1,048,576 pulses/revolution

Simple Start-up

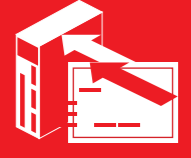

Making servo adjustment quick and simple

Let the Σ -V series simplify your life!

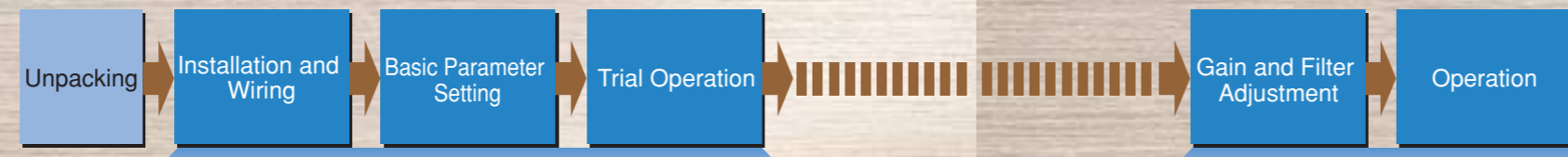

Faster setup

SigmaWin+

Setup Wizard
Simple parameter set-up with wizard-aided input

Wiring Check Function
The SigmaWin+ wiring check function checks your wiring in a single operation

Trace Function
Realtime trace of adjustment state means you can check instantly.

USB1.1 Support



Simple Tuning

New Advanced Autotuning Window

Get up and running quickly after hooking up the motor
New Tuning-less Function

Even without servo adjustment and with load changes, oscillation- and vibration-free drive is possible up to 20 times the load moment of inertia.
Settling time: 100 to 150 ms level

Minimize settling time with less vibration
New Advanced Autotuning

The reference filter and feedback gain adjustment functions have a new automatic feed forward gain adjustment for optimal adjustment performance. The friction compensation function automatically cancels out the effect of friction on machine characteristics.
Settling time: 10 ms level

Fine-tuning is a must
New "One-parameter" Tuning

Fine-tuning can tweak machine performance to the max.
Settling time: 0 to 4 ms level

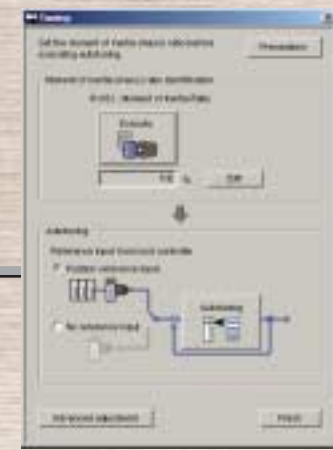

● Full of handy functions for start-up and more effective operation!

■ **Selection**
Servomotor capacity selection software
SigmaJunmaSize+
Optimal selection for your application:
With consideration of moment of inertia, DB resistance, etc.

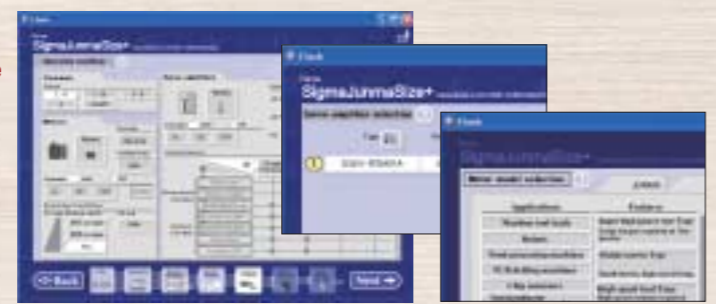

■ **Maintenance**
Faster Troubleshooting
Engineering tool
SigmaWin+
Alarm diagnostic function:
Presumes possible causes of the alarm and immediately displays suggested corrective actions.

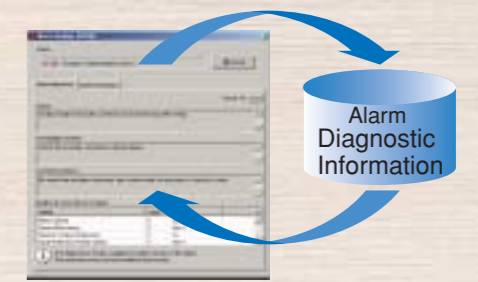

Outstanding Expandability



Use servos that really fit into your system

A rich selection of models and options to match your requirements

- Extensive variety of motors to match any machine
 Medium-inertia servomotors → Improved control stability
 Low-inertia servomotors → High-speed acceleration and deceleration
- Selection of servo actuators
 Support for direct drive servomotors, linear servomotors and linear sliders

- Standard support for three different types
 - Analog voltage/pulse train reference type
 - MECHATROLINK-II communications reference type
 - MECHATROLINK-III communications reference type

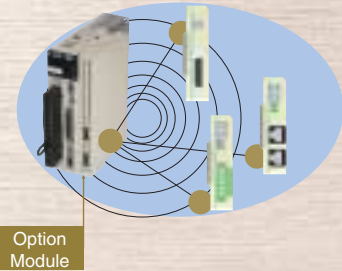

- Wide selection of option modules for various communication interfaces and feedback

- Compliant with applicable safety standards
 Easy compliance with machine safety standards

Note: Complaint with Standards: IEC61508-1 to 4 SIL2 and EN954-1 category 3 Stop category 0

The first in the industry in Japan!

- Compliant with applicable SEMI F47 standards for 200-VAC SERVOPACKS
 Easy use with applications for semiconductors and LCD manufacturing equipment

Note: SEMI F47 Standards: Specification for Semiconductor Processing Equipment Voltage Sag Immunity

- Motor line-up to handle a wide range of markets and applications

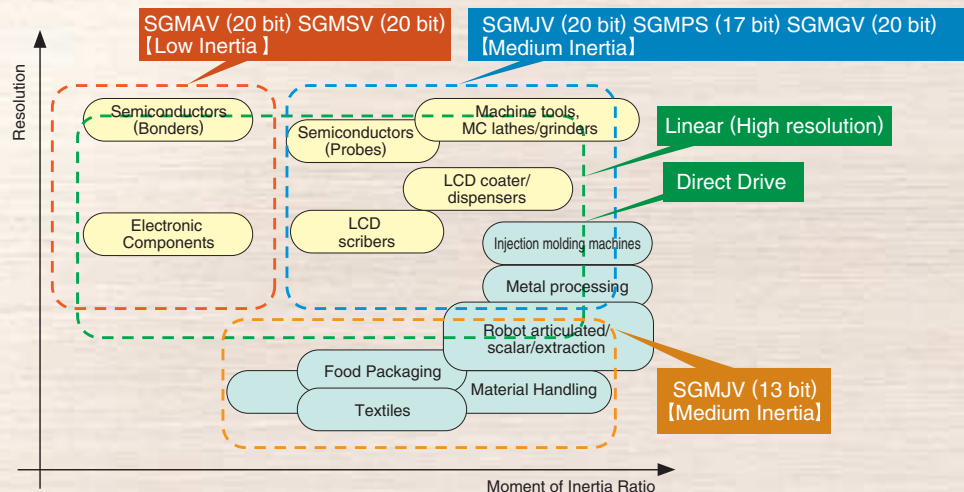

Product Line-up

Servomotors

◆ Rotary Servomotors (Small Capacity)



SGMJV
(Medium Inertia, Small Capacity)
50 W to 750 W



SGMAV
(Low Inertia, Small Capacity)
50 W to 1 kW



SGMPS
(Medium Inertia, Small Capacity, Flat Type)
100 W to 1.5 kW

◆ Rotary Servomotors (Medium Capacity)



SGMGV
(Medium Inertia, Medium Capacity)
300 W to 15 kW



SGMSV
(Low Inertia, Medium Capacity)
1.0 kW to 7.0 kW

◆ Direct Drive Servomotors



SGMCS (Small Capacity)
2 to 35 N·m



SGMCS (Medium Capacity)
45 to 200 N·m

◆ Linear Servomotors Linear Σ Series



SGLGW (Coreless Type)
12.5 to 750 N



SGLFW (With F-type Iron Core)
25 to 1120 N



SGLTW (With T-type Iron Core)
130 to 1300 N



◆ Cylinder Type Linear Servomotor
 Σ -Stick Series

SGLC
17 to 180 N

◆ Linear Sliders Σ -Trac Series



SGT (Σ -Trac)
47 to 560 N



SGTMM (Σ -Trac- μ)
3.5 to 7 N



SGTMF (Σ -Trac-MAG)
90 to 200 N

SERVOPACKs

◆ Analog Voltage /Pulse Train Reference



SGDV-□□□□01/05 SERVOPACK

◆ MECHATROLINK-II Communications Reference



SGDV-□□□□11/15 SERVOPACK

◆ MECHATROLINK-III Communications Reference



SGDV-□□□□21/25 SERVOPACK

◆ With Option Module



◆ Rotary Servomotors and SERVOPACKs

Rotary Servomotor Model		Capacity	SERVOPACK Model SGD□□□□			
			Single-phase 100 VAC	Three-phase 200 VAC	Three-phase 400 VAC	
SGMJV (Medium Inertia, Small Capacity) 3000 min ⁻¹	SGMJV-A5A	50 W	R70F	R70A	—	
	SGMJV-01A	100 W	R90F	R90A		
	SGMJV-02A	200 W	2R1F	1R6A		
	SGMJV-04A	400 W	2R8F	2R8A		
	SGMJV-08A	750 W	—	5R5A		
SGMAV (Low Inertia, Small Capacity) 3000 min ⁻¹	SGMAV-A5A	50 W	R70F	R70A	—	
	SGMAV-01A	100 W	R90F	R90A		
	SGMAV-C2A	150 W	2R1F	1R6A		
	SGMAV-02A	200 W				
	SGMAV-04A	400 W	2R8F	2R8A		
	SGMAV-06A	550 W	—	5R5A		
	SGMAV-08A	750 W				
SGMAV-10A	1 kW	120A*1				
SGMPS (Medium Inertia, Small Capacity, Flat Type) 3000 min ⁻¹	SGMPS-01A	100 W	R90F	R90A	—	
	SGMPS-02A	200 W	2R1F	2R8A		
	SGMPS-04A	400 W	2R8F			
	SGMPS-08A	750 W	—	5R5A		
	SGMPS-15A	1.5 kW		120A*1		
SGMSV (Low Inertia, Medium Capacity) 3000 min ⁻¹	SGMSV-10A	1.0 kW	—	7R6A	—	
	SGMSV-15A	1.5 kW		120A		
	SGMSV-20A	2.0 kW		180A		
	SGMSV-25A	2.5 kW		200A		
	SGMSV-30A	3.0 kW				
	SGMSV-40A	4.0 kW		330A		
	SGMSV-50A	5.0 kW		550A		
	SGMSV-70A	7.0 kW				
	SGMSV-10D	1.0 kW	—	—	3R5D	
	SGMSV-15D	1.5 kW			5R4D	
	SGMSV-20D	2.0 kW			8R4D	
	SGMSV-25D	2.5 kW			120D	
	SGMSV-30D	3.0 kW				
	SGMSV-40D	4.0 kW				
	SGMSV-50D	5.0 kW			170D	
	SGMGV (Medium Inertia, Medium Capacity) 1500 min ⁻¹	SGMGV-03A	300 W	—	3R8A	—
		SGMGV-05A	450 W		7R6A	
SGMGV-09A		850 W	120A			
SGMGV-13A		1.3 kW	180A			
SGMGV-20A		1.8 kW	330A/200A*2			
SGMGV-30A		2.9 kW				
SGMGV-44A		4.4 kW	330A			
SGMGV-55A		5.5 kW	470A			
SGMGV-75A		7.5 kW	550A			
SGMGV-1AA		11 kW	590A			
SGMGV-1EA		15 kW	780A			
SGMGV-03D		300 W	—	—	1R9D	
SGMGV-05D		450 W			3R5D	
SGMGV-09D		850 W			5R4D	
SGMGV-13D		1.3 kW			8R4D	
SGMGV-20D		1.8 kW			120D	
SGMGV-30D		2.9 kW			170D	
SGMGV-44D		4.4 kW			210D	
SGMGV-55D		5.5 kW			260D	
SGMGV-75D		7.5 kW			280D	
SGMGV-1AD		11 kW			370D	
SGMGV-1ED		15 kW				

*1: Single-phase 200 VAC SERVOPACKs are also available (base-mounted SERVOPACK model: SGD□V-120A□□□A008000, rack-mounted SERVOPACK model: SGD□V-120A□□□A009000).

*2: The combination of the SGD□V-200A SERVOPACK and the SGM□V-30A servomotor must be used at the following reduction ratings.

SERVOPACK Model	SGDV-200A	Reduction Ratings	Ratings
Rated Current	Arms	19.6	23.8
Rated Torque	N · m	15.3	18.6
Allowable Load Moment of Inertia		3 times	5 times

◆ Linear Servomotors and SERVOPACKs

Linear Servomotor Model		Rated Force N	Peak Force N	SERVOPACK Model SGD□-□□□□			
				Single-phase 100 VAC	Three-phase 200 VAC	Three-phase 400 VAC	
SGLGW (Coreless Type, With standard magnetic way)	SGLGW-30A050C	12.5	40	R70F	R70A	—	
	SGLGW-30A080C	25	80	R90F	R90A		
	SGLGW-40A140C	47	140				
	SGLGW-40A253C	93	280	2R1F	1R6A		
	SGLGW-60A140C	70	220				
	SGLGW-40A365C	140	420	2R8F	2R8A		
	SGLGW-60A253C	140	440				
	SGLGW-60A365C	210	660	—	5R5A		
	SGLGW-90A200C	325	1300		120A		
	SGLGW-90A370C	550	2200		180A		
	SGLGW-90A535C	750	3000		200A		
SGLGW (Coreless Type, With high-efficiency magnetic way)	SGLGW-40A140C	57	230	2R1F	1R6A	—	
	SGLGW-60A140C	85	360				
	SGLGW-40A253C	114	460	2R8F	2R8A		
	SGLGW-40A365C	171	690		—		3R8A
	SGLGW-60A253C	170	720				7R6A
SGLFW (With F-type Iron Core)	SGLFW-20A090A	25	86	2R1F	1R6A	—	
	SGLFW-20A120A	40	125				
	SGLFW-35A120A	80	220				
	SGLFW-35A230A	160	440				
	SGLFW-50A200B	280	600	—	3R8A		
	SGLFW-50A380B	560	1200		5R5A		
	SGLFW-1ZA200B	560	1200		120A		
	SGLFW-1ZA380B	1120	2400		200A		
	SGLFW-35D120A	80	220	—	—		1R9D
	SGLFW-35D230A	160	440				3R5D
	SGLFW-50D200B	280	600				5R4D
	SGLFW-50D380B	560	1200				120D
	SGLFW-1ZD200B	560	1200				
	SGLFW-1ZD380B	1120	2400				
SGLTW (With T-type Iron Core)	SGLTW-20A170A	130	380			—	3R8A
	SGLTW-35A170A	220	660				
	SGLTW-35A170H	300	600	5R5A			
	SGLTW-50A170H	450	900	7R6A			
	SGLTW-20A320A	250	760				
	SGLTW-20A460A	380	1140	120A			
	SGLTW-35A320A	440	1320				
	SGLTW-35A320H	600	1200				
	SGLTW-50A320H	900	1800				
	SGLTW-35A460A	670	2000	180A			
	SGLTW-40A400B	670	2600				
	SGLTW-40A600B	1000	4000	330A			
	SGLTW-80A400B	1300	5000				
	SGLTW-80A600B	2000	7500	550A			
	SGLTW-35D170H	300	600		—		3R5D
	SGLTW-50D170H	450	900	8R4D			
	SGLTW-35D320H	600	1200				
	SGLTW-50D320H	900	1800	120D			
	SGLTW-40D400B	670	2600				
	SGLTW-40D600B	1000	4000	170D			
SGLTW-80D400B	1300	5000					
SGLTW-80D600B	2000	7500	260D				

◆ Cylinder Type Servomotors (Σ -Stick) and SERVOPACKS

Linear Servomotor Model		Rated Force N	Peak Force N	SERVOPACK Model SGD Σ V-□□□□	
				Single-phase 100 VAC	Three-phase 200 VAC
SGLC	SGLC-D16A085	17	60	R70F	R70A
	SGLC-D16A115	25	90		
	SGLC-D16A145	34	120		
	SGLC-D20A100	30	150	2R1F	1R6A
	SGLC-D20A135	45	225		2R8A
	SGLC-D20A170	60	300		1R6A
	SGLC-D25A125	70	280		2R8A
	SGLC-D25A170	105	420	2R8F	2R8A
	SGLC-D32A165	90	420		
	SGLC-D25A215	140	560	—	5R5A
	SGLC-D32A225	135	630		
SGLC-D32A285	180	840			

◆ Linear Sliders (Σ -Trac) and SERVOPACKS

Linear Slider Model		Rated Force N	Peak Force N	SERVOPACK Model SGD Σ V-□□□□	
				Single-phase 100 VAC	Three-phase 200 VAC
SGT (Σ -Trac)	SGT□GD□	47	140	R90F	R90A
	SGT□GE□	93	280	2R1F	1R6A
	SGT□GG□	70	220		
	SGT□GF□	140	420	2R8F	2R8A
	SGT□GH□	140	440		
	SGT□GI□	210	660	—	5R5A
	SGT□F3□	80	220	2R1F	1R6A
	SGT□F4□	160	440	—	3R8A
	SGT□F9□	280	600		5R5A
	SGT□FA□	560	1200		120A
SGTMM (Σ -Trac- μ)	SGTMM01	3.5	10	R70F	R70A
	SGTMM03	7	25	R90F	R90A
SGTMF (Σ -Trac-MAG)	SGTMF4A	90	270	2R1F	1R6A
	SGTMF4B	120	360		
	SGTMF5A	150	540	—	5R5A
	SGTMF5B	200	720		

◆ Direct Drive Servomotors and SERVOPACKS

Direct Drive Servomotor Model		Rated Torque N · m	Peak Torque N · m	SERVOPACK Model SGD Σ V-□□□□		
				Single-phase 100 VAC	Three-phase 200 VAC	
SGMCS (Small Capacity)	SGMCS-02B	2	6	2R1F	2R8A	
	SGMCS-05B	5	15			
	SGMCS-07B	7	21			
	SGMCS-04C	4	12	2R8F		
	SGMCS-10C	10	30			
	SGMCS-14C	14	42			
	SGMCS-08D	8	24			
	SGMCS-17D	17	51			
	SGMCS-25D	25	75			
	SGMCS-16E	16	48	—		5R5A
	SGMCS-35E	35	105	—		
SGMCS-45M	45	135	7R6A			
SGMCS-80M	80	240	120A			
SGMCS-80N	80	240	180A			
SGMCS-1AM	110	330	200A			
SGMCS-1EN	150	450				
SGMCS-2ZN	200	600				

Servomotors

Rotary Servomotors 1

Medium inertia, small capacity	SGMJV	1
Low inertia, small capacity	SGMAV	23
Medium inertia, small capacity (Flat type)	SGMPS	47
Medium inertia, medium capacity	SGMGV	71
Low inertia, medium capacity	SGMSV	93
Rotary Servomotor General Instructions		111

Direct Drive Servomotors 121

Small capacity, medium capacity	SGMCS	121
---------------------------------	-------	-----

Linear Servomotors 139

Coreless type	SGLGW	139
With F-type iron core	SGLFW	159
With T-type iron core	SGLTW	179
Cylinder type Σ -Stick	SGLC	207
Linear Servomotor General Instructions		221

Linear Sliders 229

Σ -Trac	SGT	229
Σ -Trac- μ	SGTMM	241
Σ -Trac-MAG	SGTMF	249

SERVOPACKs

Analog Voltage/Pulse Train Reference Type SERVOPACKs 257

SGDV-□□□□01/05	257
With option module	321
Option Module for Fully-closed Loop Control SGD□□□□□□□□□□□□□□001	339

MECHATROLINK-II Communications Reference Type SERVOPACKs 281

SGDV-□□□□11/15	281
With option module	321
Option Module for Fully-closed Loop Control SGD□□□□□□□□□□□□□□001	339

MECHATROLINK-III Communications Reference Type SERVOPACKs 303

SGDV-□□□□21/25	303
With option module	321
Option Module for Fully-closed Loop Control SGD□□□□□□□□□□□□□□001	339

Wiring Main Circuit and Peripheral Devices 345

Others

Selecting Servomotor Capacity and Regenerative Capacity 363

Connection to Host Controller 379

Detailed Contents

Servomotors

Rotary Servomotors

SGMJV 1

Model Designations	1
Ratings and Specifications	3
External Dimensions Units: mm	6
Selecting Cables	8
With Low-backlash Gears Ratings and Specifications	15
With Low-backlash Gears External Dimensions Units: mm	17

SGMAV 23

Model Designations	23
Ratings and Specifications	25
External Dimensions Units: mm	28
Selecting Cables	30
With Low-backlash Gears Ratings and Specifications	39
With Low-backlash Gears External Dimensions Units: mm	41

SGMPS 47

Model Designations	47
Ratings and Specifications	49
External Dimensions Units: mm	52
Selecting Cables	54
With Low-backlash Gears Ratings and Specifications	63
With Low-backlash Gears External Dimensions Units: mm	65
Flange-type With Low-backlash Gears Ratings and Specifications	67
Flange-type With Low-backlash Gears External Dimensions Units: mm	69

SGMGV 71

Model Designations	71
Ratings and Specifications	73
External Dimensions Units: mm	76
Selecting Cables (SGMGV-03/-05)	83
Selecting Cables (SGMGV-09 to -1E)	85
Selecting Cables	89

SGMSV 93

Model Designations	93
Ratings and Specifications	95
External Dimensions Units: mm	98
Selecting Cables	102

Rotary Servomotor General Instructions 111

Precautions on Servomotor Installation	111
Cable Connections to SGMJV, SGMAV and SGMPS Servomotors	113
Cable Connections to SGMGV-03/-05 Servomotors	114
Mechanical Specifications	115
Rotor Moment of Inertia	115
Servomotor Heating Conditions	116
Holding Brake Delay Time	117

Terms for Servomotors with Gears	118
Cables	119
Battery Case	120

Direct Drive Servomotors

SGMCS 121

Model Designations	121
Ratings and Specifications	123
Mechanical Specifications	126
External Dimensions Units: mm	127
Selecting Cables	133

Linear Servomotors

SGLGW (Coreless Type) 139

Model Designations	139
Ratings and Specifications	141
External Dimensions Units: mm	145
Selecting Cables	156

SGLFW (With F-type iron core) 159

Model Designations	159
Ratings and Specifications	161
External Dimensions Units: mm	163
Selecting Cables	174

SGLTW (With T-type iron core) 179

Model Designations	179
Ratings and Specifications	181
External Dimensions Units: mm	184
Selecting Cables	202

SGLC (Cylinder Type) 207

Model Designations	207
Ratings and Specifications	209
External Dimensions Units: mm	211
Selecting Cables	219

Linear Servomotor General Instructions 221

Serial Converter Unit (Model: JZDP-□00□-□□□-E)	221
Flexible Cables	228

Linear Sliders

Σ-Trac 229

Model Designations	229
SGT1F3□ and SGT1F4□ Linear Sliders	231
SGT1F9□ and SGT1FA□ Linear Sliders	233

SGT1GD□, SGT1GE□, and SGT1GF□ Linear Sliders	235
SGT1GG□, SGT1GH□, and SGT1GI□ Linear Sliders	237
Selecting Cables and Connectors	239

Σ-Trac-μ	241
Model Designations	241
SGTMM Linear Sliders	243
Selecting Cables and Connectors	247

Σ-Trac-MAG	249
Model Designations	249
SGTMF4 Linear Sliders	251
SGTMF5 Linear Sliders	253
Selecting Cables and Connectors	255

SERVOPACKs

Analog Voltage/Pulse Train Reference Type SERVOPACKs

SGDV-□□□□01 (For Rotary Servomotors)	
SGDV-□□□□05 (For Linear Servomotors)	257
Model Designations	257
Ratings	258
Specifications	259
Power Supply Capacities and Power Losses	262
External Dimensions Units: mm	263
Selecting Cables	275

MECHATROLINK-II Communications Reference Type SERVOPACKs

SGDV-□□□□11 (For Rotary Servomotors)	
SGDV-□□□□15 (For Linear Servomotors)	281
Model Designations	281
Ratings	282
Specifications	283
Power Supply Capacities and Power Losses	285
External Dimensions Units: mm	286
Selecting Cables	298

MECHATROLINK-III Communications Reference Type SERVOPACKs

SGDV-□□□□21 (For Rotary Servomotors)	
SGDV-□□□□25 (For Linear Servomotors)	303
Model Designations	303
Ratings	304
Specifications	305
Power Supply Capacities and Power Losses	307
External Dimensions Units: mm	308
Selecting Cables	316

SERVOPACK with Option Module

Model Designations	321
Precautions	322
External Dimensions Units: mm (for Analog Voltage/Pulse Train Reference Type SERVOPACKs)	323
External Dimensions Units: mm (for MECHATROLINK-II Communications Reference Type SERVOPACKs)	331

Option Module for Fully-closed Loop Control

Option Module for Fully-closed Loop Control	340
Serial Converter Units	341

Wiring Main Circuit and Peripheral Devices

Wiring Main Circuit	345
SERVOPACK Main Circuit Wire	348
Molded-case Circuit Breaker and Fuse Capacity	350
Noise Filters	351
Surge Absorber	354
Magnetic Contactors	355
AC/DC Reactors	358
Holding Brake Power Supply Unit	359
Regenerative Resistors	360

Others

Selecting Servomotor Capacity and Regenerative Capacity

Servomotor Capacity Selection Examples	363
Selecting Regenerative Resistors	368

Connection to Host Controller

Example of Connection to Machine Controller MP2□□□	379
Example of Connection to MP2200/MP2300 Motion Module SVA-01	380
Example of Connection to MP920 4-axes Analog Module SVA-01	381
Example of Connection to OMRON's Motion Control Unit	382
Example of Connection to OMRON's Position Control Unit	383
Example of Connection to Mitsubishi's AD72 Positioning Unit (SERVOPACK in Speed Control)	384
Example of Connection to Mitsubishi's AD75 Positioning Unit (SERVOPACK in Position Control)	385
Example of Connection to Mitsubishi's QD75D□ Positioning Unit (SERVOPACK in Position Control)	386

Read Before Ordering

Rotary Servomotors

SGMJV



Model Designations

• Without Gears

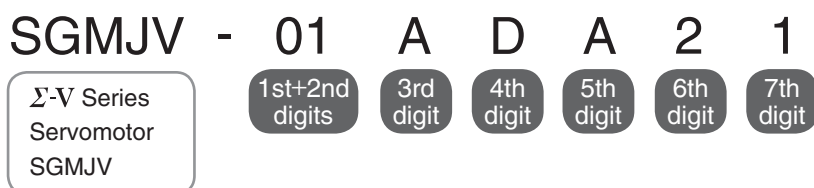

1st+2nd digits Rated Output

Code	Specifications
A5	50 W
01	100 W
02	200 W
04	400 W
08	750 W

3rd digit Power Supply Voltage

Code	Specifications
A	200 VAC

4th digit Serial Encoder

Code	Specifications
3	20-bit absolute (standard)*
D	20-bit incremental (standard)
A	13-bit incremental (standard)

5th digit Design Revision Order

Code	Specifications
A	Standard

6th digit Shaft End

Code	Specifications
2	Straight without key (standard)
6	Straight with key and tap (optional)
B	With two flat seats (optional)

7th digit Options

Code	Specifications
1	Without options
C	With holding brake (24 VDC)
E	With oil seal and holding brake (24 VDC)
S	With oil seal

*: When exporting the servomotors themselves, export restrictions may apply. Follow each country's export restrictions.

Features

- Medium inertia
- Instantaneous peak torque (350% of rated torque)
- Mounted high-resolution serial encoder: 13, 20 bits
- Maximum speed: 6,000 min⁻¹
- Wide Selection: 50 to 750 W capacity, holding brake and gear options

Application Examples

- Semiconductor equipment
- Chip mounters
- PCB drilling stations
- Robots
- Material handling machines
- Food processing equipment

● With Gears

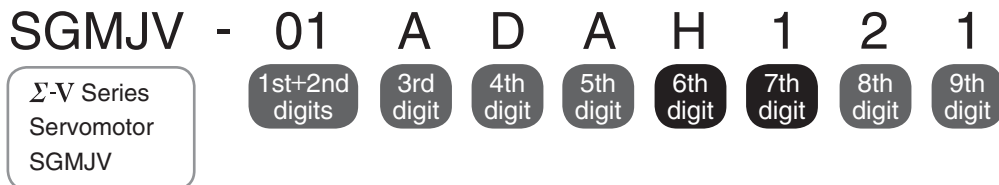

1st+2nd digits Rated Output

Code	Specifications
A5	50 W
01	100 W
02	200 W
04	400 W
08	750 W

3rd digit Power Supply Voltage

Code	Specifications
A	200 VAC

4th digit Serial Encoder

Code	Specifications
3	20-bit absolute (standard)*
D	20-bit incremental (standard)
A	13-bit incremental (standard)

5th digit Design Revision Order

Code	Specifications
A	Standard

6th digit Gear Type

Code	Specifications
H	HDS planetary low-backlash gear

7th digit Gear Ratio

Code	Specifications
B	1/11 (Not available: 50 W)
C	1/21
1	1/5
2	1/9 (Only 50 W)
7	1/33

8th digit Shaft End

Code	Specifications
0	Flange output
2	Straight without key
6	Straight with key and tap

9th digit Options

Code	Specifications
1	Without options
C	With holding brake (24 VDC)

*: When exporting the servomotors themselves, export restrictions may apply. Follow each country's export restrictions.

Ratings and Specifications

Time Rating: Continuous
Vibration Class: V15
Insulation Resistance: 500 VDC, 10 MΩ min.
Ambient Temperature: 0 to 40°C
Excitation: Permanent magnet
Mounting: Flange-mounted
Thermal Class: B

Withstand Voltage: 1500 VAC for one minute
Enclosure: Totally enclosed, self-cooled, IP65 (except for shaft opening)
Ambient Humidity: 20% to 80% (no condensation)
Drive Method: Direct drive
Rotation Direction: Counterclockwise (CCW) with forward run reference when viewed from the load side

Voltage		200 V				
Servomotor Model: SGMJV-□□□		A5A	01A	02A	04A	08A
Rated Output*1	W	50	100	200	400	750
Rated Torque*1, *2	N·m	0.159	0.318	0.637	1.27	2.39
Instantaneous Peak Torque*1	N·m	0.557	1.11	2.23	4.46	8.36
Rated Current*1	Arms	0.61	0.84	1.6	2.7	4.7
Instantaneous Max. Current*1	Arms	2.1	2.9	5.8	9.3	16.9
Rated Speed*1	min ⁻¹	3000				
Max. Speed*1	min ⁻¹	6000				
Torque Constant	N·m/Arms	0.285	0.413	0.435	0.512	0.544
Rotor Moment of Inertia	×10 ⁻⁴ kg·m ²	0.0414 (0.0561)	0.0665 (0.0812)	0.259 (0.323)	0.442 (0.506)	1.57 (1.74)
Rated Power Rate*1	kW/s	6.11	15.2	15.7	36.5	36.3
Rated Angular Acceleration*1	rad/s ²	38400	47800	24600	28800	15200
Applicable SERVOPACK	SGDV-□□□□	R70□	R90□	1R6A,2R1F	2R8□	5R5A

*1: These items and torque-motor speed characteristics quoted in combination with an SGD V SERVOPACK are at an armature winding temperature of 100°C. Other values quoted are at 20°C.

*2: Rated torques are continuous allowable torque values at 40°C with an aluminum heat sink of the following dimensions attached.

SGMJV-A5A, -01A: 200 mm×200 mm×6 mm

SGMJV-02A, -04A, -08A: 250 mm×250 mm×6 mm

Note: The values in parentheses are for servomotors with holding brakes.

● Torque-Motor Speed Characteristics A : Continuous Duty Zone B : Intermittent Duty Zone^(Note3)

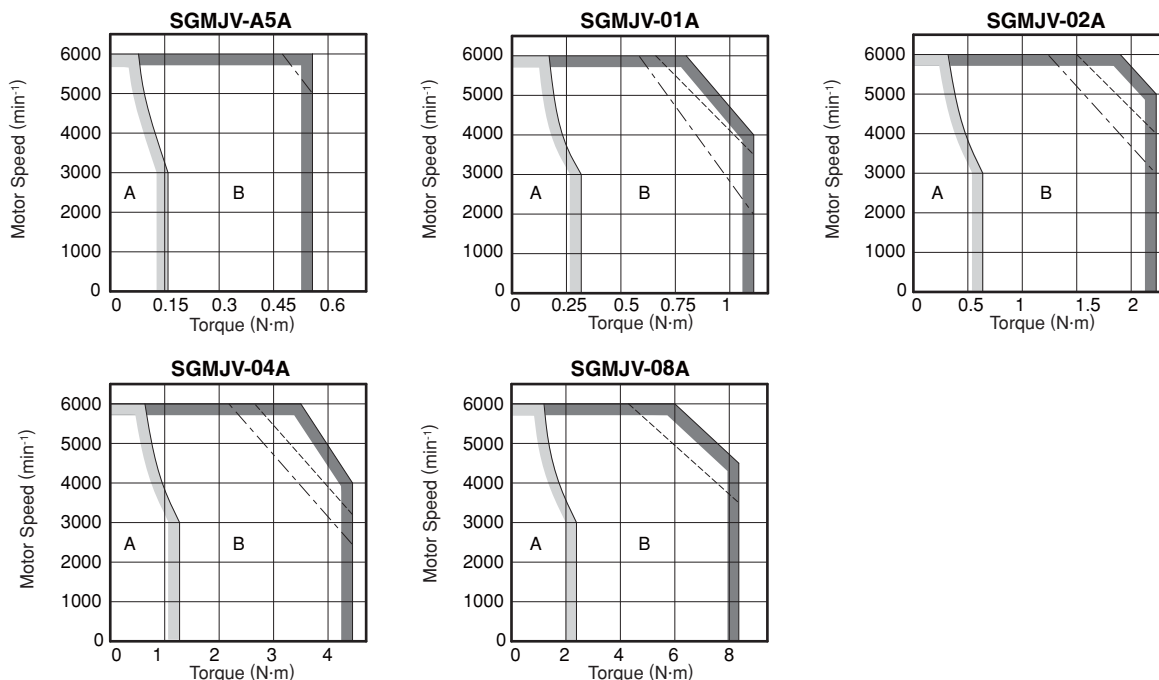

Notes: 1 The solid, dotted, and dashed-dotted lines of the intermittent duty zone indicate the characteristics when a servomotor runs with the following combinations:

- The solid line: With a three-phase 200 V or a single-phase 230 V SERVOPACK
- The dotted line: With a single-phase 200 V SERVOPACK
- The dashed-dotted line: With a single-phase 100 V SERVOPACK

An SGMJV-A5A servomotor has the same characteristics in combination with three-phase 200 V and single-phase 200 V SERVOPACKs.

2 The characteristics of the intermittent duty zone differ depending on the supply voltages.

3 When the effective torque during intermittent duty is within the rated torque, the servomotor can be used within the intermittent duty zone.

4 When the main circuit cable length exceeds 20 m, note that the intermittent duty zone of the *Torque-Motor Speed Characteristics* will shrink as the line-to-line voltage drops.

Ratings and Specifications

● Derating Rate for Servomotor Fitted with an Oil Seal

When a motor is fitted with an oil seal, use the following derating rate because of the higher friction torque.

Servomotor Model SGMJV-	A5A	01A	02A	04A	08A
Derating Rate %	80	90		95	

● Holding Brake Electrical Specifications

Holding Brake Rated Voltage	Servomotor Model	Servomotor Rated Output W	Holding Brake Specifications					
			Capacity W	Holding Torque N·m	Coil Resistance Ω (at 20°C)	Rated Current A(at 20°C)	Brake Release Time ms	Brake Operation Time ms
24 VDC ^{+10%} ₀	SGMJV-A5A	50	5.5	0.159	103	0.23	60	100
	SGMJV-01A	100	5.5	0.318	103	0.23	60	100
	SGMJV-02A	200	6	0.637	97.4	0.25	60	100
	SGMJV-04A	400	6	1.27	97.4	0.25	60	100
	SGMJV-08A	750	6.5	2.39	87.7	0.27	80	100

Notes: 1 The holding brake is only used to hold the load and cannot be used to stop the servomotor.

2 The holding brake open time and holding brake operation time vary depending on which discharge circuit is used. Make sure holding brake open time and holding brake operation time are correct for your servomotor.

3 A 24-VDC power supply is provided by customers.

● Overload Characteristics

The overload detection level is set under hot start conditions at a servomotor ambient temperature of 40°C.

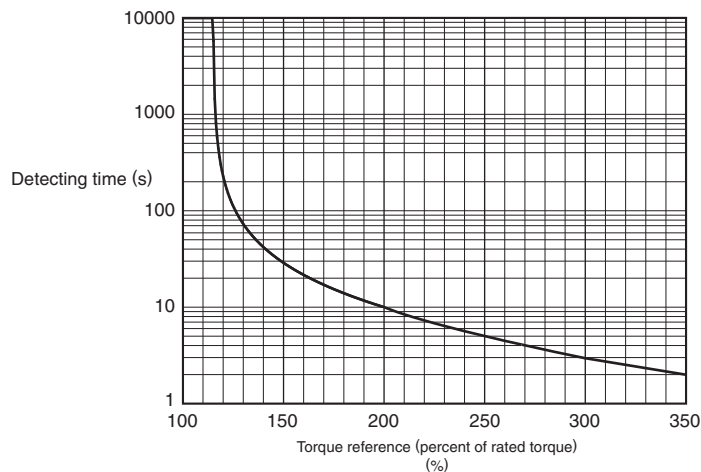

Note: Overload characteristics shown above do not guarantee continuous duty of 100% or more output. Use a servomotor with effective torque within the continuous duty zone of *Torque-Motor Speed Characteristics*.

Ratings and Specifications

● Allowable Load Moment of Inertia at the Motor Shaft

The rotor moment of inertia ratio is the value for a servomotor without a gear and a holding brake.

Servomotor Model		Servomotor Rated Output	Allowable Load Moment of Inertia (Rotor Moment of Inertia Ratio)
SGMJV-	A5A, 01A	50, 100 W	20 times
	02A	200 W	15 times
	04A, 08A	400, 750 W	10 times

● Load Moment of Inertia

The larger the load moment of inertia, the worse the movement response.

The allowable load moment of inertia (J_L) depends on the motor capacity, as shown above. This value is provided strictly as a guideline and results may vary depending on servomotor drive conditions.

Use the AC servo drive capacity selection program SigmaJunmaSize+ to check the operation conditions.

The program can be downloaded for free from our web site (<http://www.e-mechatronics.com/>) .

An overvoltage alarm (A.400) is likely to occur during deceleration if the load moment of inertia exceeds the allowable load moment of inertia. SERVOPACKs with a built-in regenerative resistor may generate a regenerative overload alarm (A.320). Take one of the following steps if this occurs.

- Reduce the torque limit.
- Reduce the deceleration rate.
- Reduce the maximum speed.
- Install an external regenerative resistor if the alarm cannot be cleared using the steps above. Refer to *Regenerative Resistors* on page 360.

Regenerative resistors are not built into SERVOPACKs for 400 W motors or less.

External regenerative resistors are required when this condition is exceeded or if the allowable loss capacity (W) of the built-in regenerative resistor is exceeded due to regenerative drive conditions when a regenerative resistor is already built in.

● Allowable Radial and Thrust Loads

Design the mechanical system so thrust and radial loads applied to the servomotor shaft end during operation fall within the ranges shown in the table.

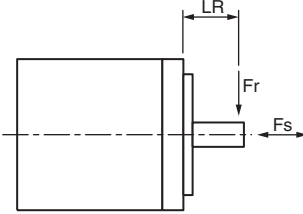
Servomotor Model		Allowable Radial Load (F_r) N	Allowable Thrust Load (F_s) N	LR mm	Reference Diagram
SGMJV-	A5A	78	54	20	
	01A				
	02A	245	74	25	
	04A				
	08A				

External Dimensions Units: mm

(1) 50, 100 W

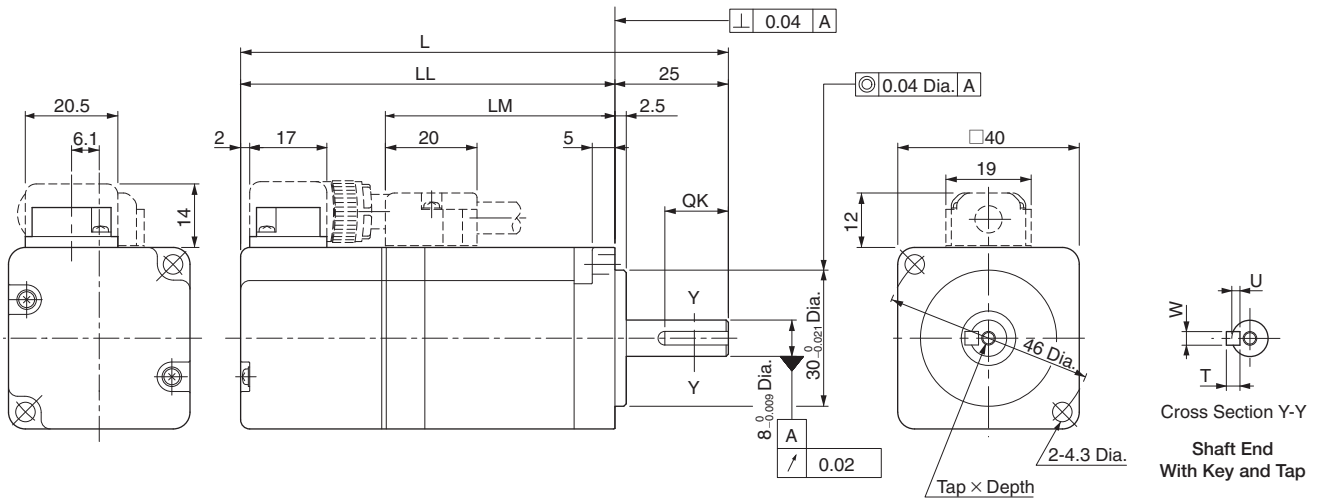

Model SGMJV-	L	LL	LM	Tap x Depth	Key Dimensions				Approx. Mass kg
					QK	U	W	T	
A5A□A21 (A5A□A2C)	94 (139)	69 (114)	37	No tap	No key				0.3 (0.6)
A5A□A61 (A5A□A6C)				M3 x 6L	14	1.8	3	3	
01A□A21 (01A□A2C)	107.5 (152.5)	82.5 (127.5)	50.5	No tap	No key				0.4 (0.7)
01A□A61 (01A□A6C)				M3 x 6L	14	1.8	3	3	

Note: The models and values in parentheses are for servomotors with holding brakes.

<Shaft End and Other Options>

● With Two Flat Seats

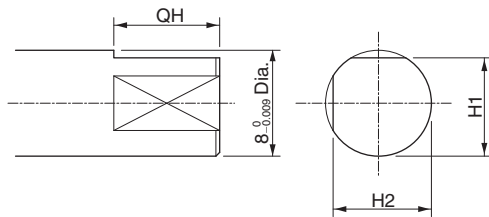

Model SGMJV-	Dimensions of Servomotor with Two Flat Seats mm		
	QH	H1	H2
A5A□AB□	15	7.5	7.5
01A□AB□			

● With an Oil Seal

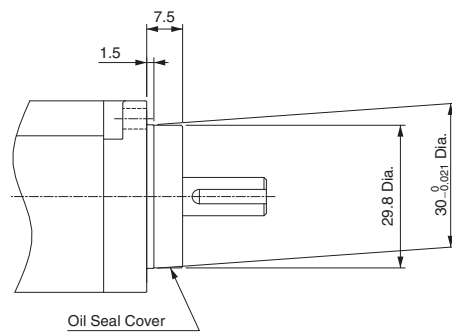

Notes: 1 The 7th digit of the model designation is "S" or "E."
2 Key dimensions are the same as those in the table above.

External Dimensions Units: mm

(2) 200 to 750 W

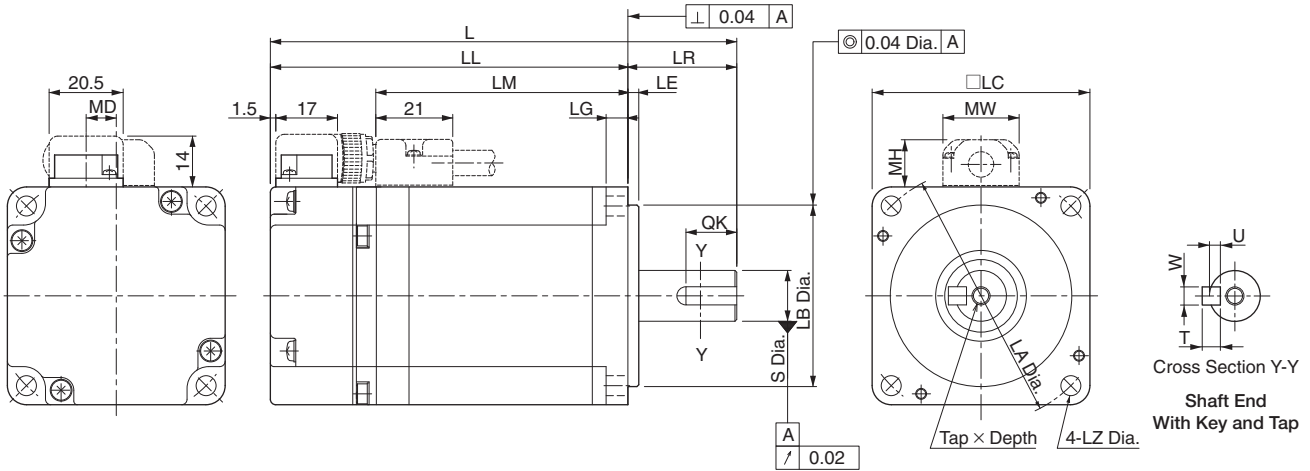

Model SGMJV-	L	LL	LM	Flange Face Dimensions								S	Tap× Depth	Key Dimensions				MD	MW	MH	Approx. Mass kg
				LR	LE	LG	LC	LA	LB	LZ	QK			U	W	T					
02A□A21 (02A□A2C)	110 (150)	80 (120)	51	30	3	6	60	70	50 ⁰ _{0.025}	5.5	14 ⁰ _{0.011}	No tap	No key				8.3	21	13	0.9 (1.5)	
02A□A61 (02A□A6C)												M5×8L	14	3	5	5					
04A□A21 (04A□A2C)	128.5 (168.5)	98.5 (138.5)	69.5	30	3	6	60	70	50 ⁰ _{0.025}	5.5	14 ⁰ _{0.011}	No tap	No key				8.3	21	13	1.3 (1.9)	
04A□A61 (04A□A6C)												M5×8L	14	3	5	5					
08A□A21 (08A□A2C)	155 (200)	115 (160)	85	40	3	8	80	90	70 ⁰ _{0.030}	7	19 ⁰ _{0.013}	No tap	No key				13.8	27	15	2.7 (3.6)	
08A□A61 (08A□A6C)												M6×10L	22	3.5	6	6					

Note: The models and values in parentheses are for servomotors with holding brakes.

<Shaft End and Other Options>

● With Two Flat Seats

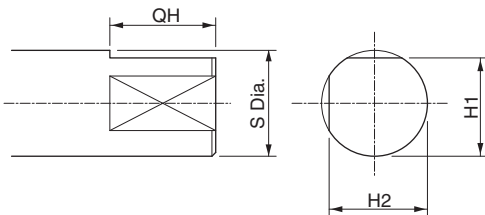

Model SGMJV-	Dimensions of Servomotor with Two Flat Seats mm			
	QH	S	H1	H2
02A□AB□	15	14 ⁰ _{0.011}	13	13
04A□AB□				
08A□AB□	22	19 ⁰ _{0.013}	18	18

● With an Oil Seal

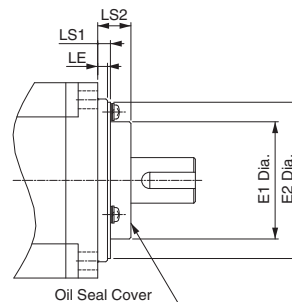

Model SGMJV-	Dimensions of Servomotor with an Oil Seal			
	E1	E2	LS1	LS2
02A, 04A	36	48	4	10
08A	49	66	6	11

Notes: 1 The 7th digit of the model designation is "S" or "E."
2 Key dimensions are the same as those in the table above.

Selecting Cables

● Cables Connections

- Standard Wiring (Max. encoder cable length: 20 m)

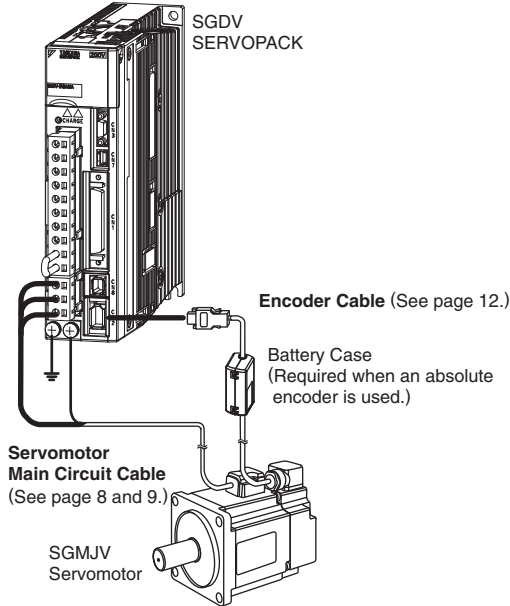

- Encoder Cable Extension from 30 to 50 m

(See page 14.)

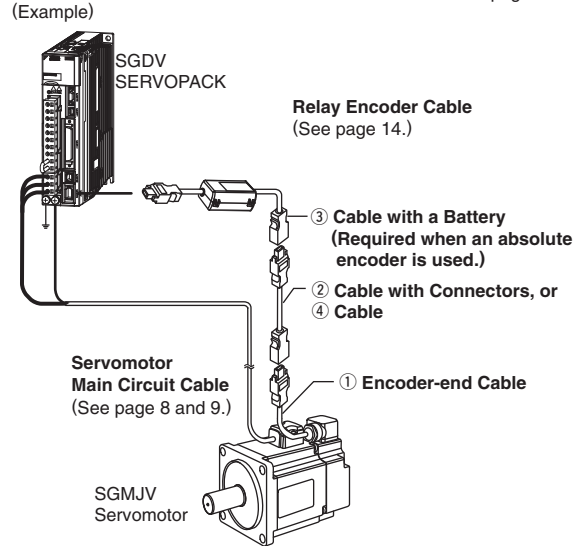

⚠ CAUTION



- Separate the servomotor main circuit cable wiring from the I/O signal cable and encoder cable at least 30 cm, and do not bundle or run them in the same duct.
- When the cable length exceeds 20 m, be sure to use a relay encoder cable.
- When the main circuit cable length exceeds 20 m, note that the intermittent duty zone of the *Torque-Motor Speed Characteristics* will shrink as the line-to-line voltage drops.

● Servomotor Main Circuit Cable

Name	Servomotor Rated Output	Length	Order No.		Specifications	Details
			Standard Type	Flexible Type*		
For Servomotor without Holding Brakes	50, 100 W	3 m	JZSP-CSM01-03-E	JZSP-CSM21-03-E		(1)
		5 m	JZSP-CSM01-05-E	JZSP-CSM21-05-E		
		10 m	JZSP-CSM01-10-E	JZSP-CSM21-10-E		
		15 m	JZSP-CSM01-15-E	JZSP-CSM21-15-E		
		20 m	JZSP-CSM01-20-E	JZSP-CSM21-20-E		
		30 m	JZSP-CSM01-30-E	JZSP-CSM21-30-E		
		40 m	JZSP-CSM01-40-E	JZSP-CSM21-40-E		
		50 m	JZSP-CSM01-50-E	JZSP-CSM21-50-E		
	200, 400 W	3 m	JZSP-CSM02-03-E	JZSP-CSM22-03-E		
		5 m	JZSP-CSM02-05-E	JZSP-CSM22-05-E		
		10 m	JZSP-CSM02-10-E	JZSP-CSM22-10-E		
		15 m	JZSP-CSM02-15-E	JZSP-CSM22-15-E		
		20 m	JZSP-CSM02-20-E	JZSP-CSM22-20-E		
		30 m	JZSP-CSM02-30-E	JZSP-CSM22-30-E		
		40 m	JZSP-CSM02-40-E	JZSP-CSM22-40-E		
		50 m	JZSP-CSM02-50-E	JZSP-CSM22-50-E		
	750 W	3 m	JZSP-CSM03-03-E	JZSP-CSM23-03-E		
		5 m	JZSP-CSM03-05-E	JZSP-CSM23-05-E		
		10 m	JZSP-CSM03-10-E	JZSP-CSM23-10-E		
		15 m	JZSP-CSM03-15-E	JZSP-CSM23-15-E		
		20 m	JZSP-CSM03-20-E	JZSP-CSM23-20-E		
		30 m	JZSP-CSM03-30-E	JZSP-CSM23-30-E		
		40 m	JZSP-CSM03-40-E	JZSP-CSM23-40-E		
		50 m	JZSP-CSM03-50-E	JZSP-CSM23-50-E		

(Cont'd)

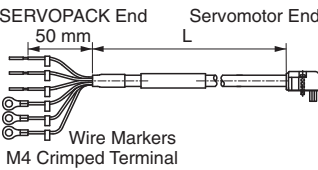
Selecting Cables

Name	Servomotor Rated Output	Length	Order No.		Specifications	Details
			Standard Type	Flexible Type*		
For Servomotor with Holding Brakes	50, 100 W	3 m	JZSP-CSM11-03-E	JZSP-CSM31-03-E		(2)
		5 m	JZSP-CSM11-05-E	JZSP-CSM31-05-E		
		10 m	JZSP-CSM11-10-E	JZSP-CSM31-10-E		
		15 m	JZSP-CSM11-15-E	JZSP-CSM31-15-E		
		20 m	JZSP-CSM11-20-E	JZSP-CSM31-20-E		
		30 m	JZSP-CSM11-30-E	JZSP-CSM31-30-E		
		40 m	JZSP-CSM11-40-E	JZSP-CSM31-40-E		
	200, 400 W	3 m	JZSP-CSM12-03-E	JZSP-CSM32-03-E		
		5 m	JZSP-CSM12-05-E	JZSP-CSM32-05-E		
		10 m	JZSP-CSM12-10-E	JZSP-CSM32-10-E		
		15 m	JZSP-CSM12-15-E	JZSP-CSM32-15-E		
		20 m	JZSP-CSM12-20-E	JZSP-CSM32-20-E		
		30 m	JZSP-CSM12-30-E	JZSP-CSM32-30-E		
		40 m	JZSP-CSM12-40-E	JZSP-CSM32-40-E		
	750 W	3 m	JZSP-CSM13-03-E	JZSP-CSM33-03-E		
		5 m	JZSP-CSM13-05-E	JZSP-CSM33-05-E		
		10 m	JZSP-CSM13-10-E	JZSP-CSM33-10-E		
		15 m	JZSP-CSM13-15-E	JZSP-CSM33-15-E		
		20 m	JZSP-CSM13-20-E	JZSP-CSM33-20-E		
		30 m	JZSP-CSM13-30-E	JZSP-CSM33-30-E		
		40 m	JZSP-CSM13-40-E	JZSP-CSM33-40-E		
Servomotor-end Connector Kit	50, 100 W	JZSP-CSM9-1-E		Crimping Type (A crimp tool is required.)	(3)	
	200, 400 W	JZSP-CSM9-2-E			(4)	
	750 W	JZSP-CSM9-3-E			(5)	
Cables	50 to 400 W	5 m	JZSP-CSM90-05-E	JZSP-CSM80-05-E		(6)
		10 m	JZSP-CSM90-10-E	JZSP-CSM80-10-E		
		15 m	JZSP-CSM90-15-E	JZSP-CSM80-15-E		
		20 m	JZSP-CSM90-20-E	JZSP-CSM80-20-E		
		30 m	JZSP-CSM90-30-E	JZSP-CSM80-30-E		
		40 m	JZSP-CSM90-40-E	JZSP-CSM80-40-E		
		50 m	JZSP-CSM90-50-E	JZSP-CSM80-50-E		
	750 W	5 m	JZSP-CSM91-05-E	JZSP-CSM81-05-E		(7)
		10 m	JZSP-CSM91-10-E	JZSP-CSM81-10-E		
		15 m	JZSP-CSM91-15-E	JZSP-CSM81-15-E		
		20 m	JZSP-CSM91-20-E	JZSP-CSM81-20-E		
		30 m	JZSP-CSM91-30-E	JZSP-CSM81-30-E		
		40 m	JZSP-CSM91-40-E	JZSP-CSM81-40-E		
		50 m	JZSP-CSM91-50-E	JZSP-CSM81-50-E		

*: Use flexible cables for movable sections such as robot arms.

(1) Wiring Specifications for Servomotors without Holding Brakes (2) Wiring Specifications for Servomotor with Holding Brakes

SERVOPACK-end Leads		Servomotor-end Connector	
Wire Color	Signal	Signal	Pin No.
Green/yellow	FG	FG	1
Blue	Phase W	Phase W	2
White	Phase V	Phase V	3
Red	Phase U	Phase U	4
		—	5
		—	6

SERVOPACK-end Leads		Servomotor-end Connector	
Wire Color	Signal	Signal	Pin No.
Green/yellow	FG	FG	1
Blue	Phase W	Phase W	2
White	Phase V	Phase V	3
Red	Phase U	Phase U	4
Black	Brake	Brake	5
Black	Brake	Brake	6

Note: No polarity for connection to a holding brake.

Selecting Cables

(3) Servomotor-end Connector Kit Specifications: For 50, 100 W Servomotors

Items	Specifications	External Dimensions mm	
Order No.	JZSP-CSM9-1-E (Cables are not included.)		
Applicable Servomotors	SGMJV-A5A, -01A		
Manufacturer	J.S.T. Mfg. Co., Ltd.		
Receptacle	J17-06FMH-7KL-1-CF		
Electrical Contact	SJ1F-01GF-P0.8		
Applicable Wire Size	AWG20 to 24		
Outer Diameter of Insulating Sheath	1.11 dia. to 1.53 dia. mm		
Crimp Tool	Hand tool		YRS-8841
	Applicator		APLMK SJ1F/M-01-08
Mounting Screw	M2 Pan-head screw		
Applicable Cable Outer Diameter	7±0.3 dia. mm		

(4) Servomotor-end Connector Kit Specifications: For 200, 400 W Servomotors

Items	Specifications	External Dimensions mm	
Order No.	JZSP-CSM9-2-E (Cables are not included.)		
Applicable Servomotors	SGMJV-02A, -04A		
Manufacturer	J.S.T. Mfg. Co., Ltd.		
Receptacle	J27-06FMH-7KL-1-CF		
Electrical Contact	SJ2F-01GF-P1.0		
Applicable Wire Size	AWG20 to 24		
Outer Diameter of Insulating Sheath	1.11 dia. to 1.53 dia. mm		
Crimp Tool	Hand tool		YRS-8861
	Applicator		APLMK SJ2F/M-01-08
Mounting Screw	M2 Pan-head screw		
Applicable Cable Outer Diameter	7±0.3 dia. mm		

(5) Servomotor-end Connector Kit Specifications: For 750 W Servomotors

Items	Specifications	External Dimensions mm		
Order No.	JZSP-CSM9-3-E (Cables are not included.)			
Applicable Servomotors	SGMJV-08A			
Manufacturer	J.S.T. Mfg. Co., Ltd.			
Receptacle	J37-06FMH-8KL-1-CF			
Cable Type	Standard			
Electrical Contact	SJ3F-41GF-P1.8 (For power terminals)		SJ3F-01GF-P1.8 (For brake terminals)	
	Applicable Wire Size		AWG16 to 20	AWG20 to 24
Outer Diameter of Insulating Sheath	1.53 dia. to 2.5 dia. mm		1.11 dia. to 1.86 dia. mm	
Crimp Tool	Hand tool		YRF-880	YRF-881
	Applicator		APLMK SF3F/M-41-20	APLMK SF3F/M-01-20
Mounting Screw	M2.5 Pan-head screw			
Applicable Cable Outer Diameter	8±0.3 dia. mm			

Selecting Cables

(6) Cable Specifications: For 50 to 400 W Servomotors

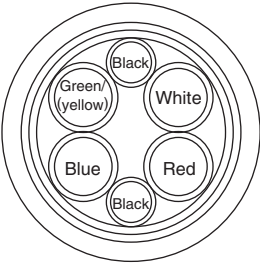
Items	Standard Type	Flexible Type
Order No.*	JZSP-CSM90-□□-E (50 m max.)	JZSP-CSM80-□□-E (50 m max.)
Specifications	UL2517 (Rating temperature: 105°C) AWG20×6C For power line: AWG20 (0.52 mm ²) Outer diameter of insulating sheath: 1.53 dia. mm For holding brake line: AWG20 (0.52 mm ²) Outer diameter of insulating sheath: 1.53 dia. mm	UL2517 (Rating temperature: 105°C) AWG22×6C For power line: AWG22 (0.33 mm ²) Outer diameter of insulating sheath: 1.37 dia. mm For holding brake line: AWG22 (0.33 mm ²) Outer diameter of insulating sheath: 1.37 dia. mm
Finished Dimensions	7±0.3 dia. mm	
Internal Configuration and Lead Color		
Yaskawa Standard Specifications (Standard Length)	Cable length: 5 m, 10 m, 15 m, 20 m, 30 m, 40 m, 50 m	

*: Specify the cable length in □□ of order no.
 Example: JZSP-CSM90-05-E (5 m)

(7) Cable Specifications: For 750 W Servomotors

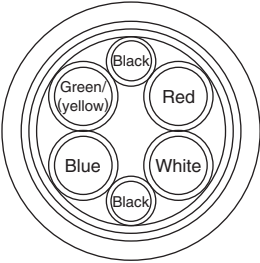
Items	Standard Type	Flexible Type
Order No.*	JZSP-CSM91-□□-E (50 m max.)	JZSP-CSM81-□□-E (50 m max.)
Specifications	UL2517 (Rating temperature: 105°C) AWG16×4C, AWG20×2C For power line: AWG16 (1.31 mm ²) Outer diameter of insulating sheath: 2.15 dia. mm For holding brake line: AWG20 (0.52 mm ²) Outer diameter of insulating sheath: 1.6 dia. mm	UL2517 (Rating temperature: 105°C) AWG16×4C, AWG22×2C For power line: AWG16 (1.31 mm ²) Outer diameter of insulating sheath: 2.35 dia. mm For holding brake line: AWG22 (0.33 mm ²) Outer diameter of insulating sheath: 1.37 dia. mm
Finished Dimensions	8±0.3 dia. mm	
Internal Configuration and Lead Color		
Yaskawa Standard Specifications (Standard Length)	Cable length: 5 m, 10 m, 15 m, 20 m, 30 m, 40 m, 50 m	

*: Specify the cable length in □□ of order no.
 Example: JZSP-CSM91-05-E (5 m)

Selecting Cables

Encoder Cables (Length: 20 m or less)

Name	Length	Order No.		Specifications	Details
		Standard Type	Flexible Type*		
Cable with Connectors (For Incremental Encoder)	3 m	JZSP-CSP01-03-E	JZSP-CSP21-03-E		(1)
	5 m	JZSP-CSP01-05-E	JZSP-CSP21-05-E		
	10 m	JZSP-CSP01-10-E	JZSP-CSP21-10-E		
	15 m	JZSP-CSP01-15-E	JZSP-CSP21-15-E		
	20 m	JZSP-CSP01-20-E	JZSP-CSP21-20-E		
Cable with Connectors (For Absolute Encoder, with a Battery Case)	3 m	JZSP-CSP05-03-E	JZSP-CSP25-03-E		(2)
	5 m	JZSP-CSP05-05-E	JZSP-CSP25-05-E		
	10 m	JZSP-CSP05-10-E	JZSP-CSP25-10-E		
	15 m	JZSP-CSP05-15-E	JZSP-CSP25-15-E		
	20 m	JZSP-CSP05-20-E	JZSP-CSP25-20-E		
SERVOPACK-end Connector Kit		JZSP-CMP9-1-E		Soldered	(3)
Encoder-end Connector Kit		JZSP-CSP9-2-E		Crimping Type (A crimp tool is required.)	
Cables	3 m	JZSP-CMP09-03-E	JZSP-CSP39-03-E		(4)
	5 m	JZSP-CMP09-05-E	JZSP-CSP39-05-E		
	10 m	JZSP-CMP09-10-E	JZSP-CSP39-10-E		
	15 m	JZSP-CMP09-15-E	JZSP-CSP39-15-E		
	20 m	JZSP-CMP09-20-E	JZSP-CSP39-20-E		

*: Use flexible cables for movable sections such as robot arms.

Note: When the battery from the host controller is used for the absolute encoder, no battery case is required. In this case, use a cable for the incremental encoders.

(1) Wiring Specifications for Cable with Connectors (For incremental encoder)

Standard Type

SERVOPACK End		Encoder (Servomotor) End	
Pin No.	Signal	Pin No.	Wire Color
6	/PS	5	Light blue/white
5	PS	4	Light blue
4	BAT (-)	8	Orange/white
3	BAT (+)	9	Orange
2	PG 0V	3	Black
1	PG 5V	6	Red
Shell	FG	Shell	FG

Flexible Type

SERVOPACK End		Encoder (Servomotor) End	
Pin No.	Signal	Pin No.	Wire Color
6	/PS	5	Black/pink
5	PS	4	Red/pink
4	BAT (-)	8	Black/light blue
3	BAT (+)	9	Red/light blue
2	PG 0V	3	Green
1	PG 5V	6	Orange
Shell	FG	Shell	FG

(2) Wiring Specifications for Cable with Connectors (For absolute encoder, with a battery case)

Standard Type

SERVOPACK End		Encoder (Servomotor) End	
Pin No.	Signal	Pin No.	Wire Color
6	/PS	5	Light blue/white
5	PS	4	Light blue
4	BAT (-)	8	Orange/white
3	BAT (+)	9	Orange
2	PG 0V	3	Black
1	PG 5V	6	Red
Shell	FG	Shell	FG

Battery Case	
Pin No.	Signal
2	BAT (-)
1	BAT (+)

Flexible Type

SERVOPACK End		Encoder (Servomotor) End	
Pin No.	Signal	Pin No.	Wire Color
6	/PS	5	Black/pink
5	PS	4	Red/pink
4	BAT (-)	8	Black/light blue
3	BAT (+)	9	Red/light blue
2	PG 0V	3	Green
1	PG 5V	6	Orange
Shell	FG	Shell	FG

Battery Case	
Pin No.	Signal
2	BAT (-)
1	BAT (+)

Selecting Cables

(3) SERVOPACK-end/Encoder-end Connector Kit Specifications

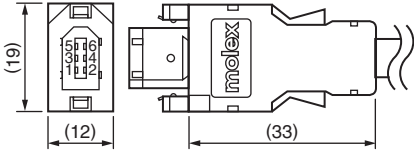
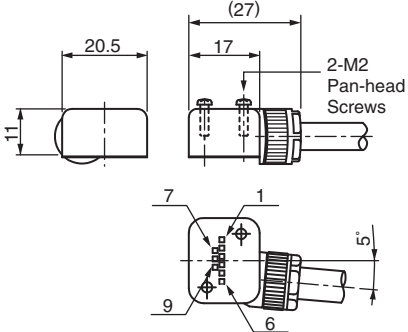
Items	SERVOPACK-end Connector Kit	Encoder-end Connector Kit
Order No.	JZSP-CMP9-1-E (Cables are not included.)	JZSP-CSP9-2-E (Cables are not included.)
Manufacturer	Molex Japan Co., Ltd.	Molex Japan Co., Ltd.
Specifications	55100-0670 (soldered) Product Specification: PS-54280	54346-0070 (crimped)* Mounting screw: M2 pan-head screw (× 2) Applicable cable outer diameter of applicable cable: 6.3 dia. to 7.7 dia. mm Applicable wire size: AWG22 to 26 Outer diameter of insulating sheath: 1.05 dia. to 1.4 dia. mm Application Specification: AS-54992 Crimping Specification: CS-56161
External Dimensions (Units: mm)		

*: A crimp tool is required.

The following crimp tools are applicable for the cables provided by Yaskawa. When using other wire sizes, contact the respective manufacturer for crimp tools.

Applicable crimp tool for Yaskawa's wire size: Hand Tool Model No. 57175-5000
Applicator Model No. 57175-3000

(4) Cable Specifications

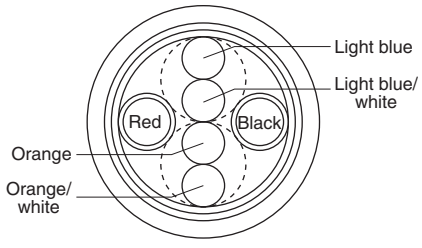
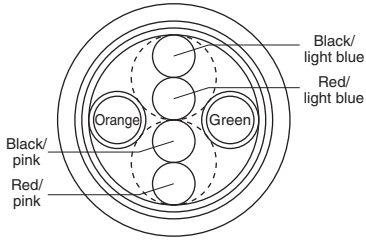
Items	Standard Type	Flexible Type
Order No.*	JZSP-CMP09-□□-E	JZSP-CSP39-□□-E
Cable Length	20 m max.	
Specifications	UL20276 (Rating temperature: 80°C) AWG22×2C+AWG24×2P AWG22 (0.33 mm ²) Outer diameter of insulating sheath: 1.15 dia. mm AWG24 (0.20 mm ²) Outer diameter of insulating sheath: 1.09 dia. mm	UL20276 (Rating temperature: 80°C) AWG22×2C+AWG24×2P AWG22 (0.33 mm ²) Outer diameter of insulating sheath: 1.35 dia. mm AWG24 (0.20 mm ²) Outer diameter of insulating sheath: 1.21 dia. mm
Finished Dimensions	6.5 dia. mm	6.8 dia. mm
Internal Configuration and Lead Color		
Yaskawa Standards Specifications (Standard Length)	Cable length: 5 m, 10 m, 15 m, 20 m	

*: Specify the cable length in □□ of order no.
Example: JZSP-CMP09-05-E (5 m)

Selecting Cables

● Relay Encoder Cables (For extending from 30 to 50 m)

Name	Length	Order No.	Specifications	Details
		Standard Type		
① Encoder-end Cables (For incremental and absolute encoder)	0.3 m	JZSP-CSP11-E	<p>SERVOPACK End 0.3 m Encoder End Plug Connector (Crimped) (Molex Japan Co., Ltd.) Connector (Molex Japan Co., Ltd.)</p>	(1)
② Cable with Connectors (For incremental and absolute encoder)	30 m	JZSP-UCMP00-30-E	<p>SERVOPACK End L Encoder End Plug Connector (Crimped) (Molex Japan Co., Ltd.) Socket Connector (Soldered) (Molex Japan Co., Ltd.)</p>	(2)
	40 m	JZSP-UCMP00-40-E		
	50 m	JZSP-UCMP00-50-E		
③ Cable with a Battery Case (Required when an absolute encoder is used.)	0.3 m	JZSP-CSP12-E*	<p>SERVOPACK End 0.3 m Encoder End Plug Connector (Crimped) (Molex Japan Co., Ltd.) Battery Case (Battery attached) Socket Connector (Soldered) (Molex Japan Co., Ltd.)</p>	(3)
④ Cables	30 m	JZSP-CMP19-30-E		(4)
	40 m	JZSP-CMP19-40-E		
	50 m	JZSP-CMP19-50-E		

*: When using an incremental encoder or using an absolute encoder with a battery connected to the host controller, no battery case is required.

(1) Wiring Specifications for Encoder-end Cable

SERVOPACK End		Encoder (Servomotor) End	
Pin No.	Signal	Pin No.	Wire Color
6	/PS	5	Light blue/white
5	PS	4	Light blue
4	BAT (-)	8	Orange/white
3	BAT (+)	9	Orange
2	PG 0V	3	Black
1	PG 5V	6	Red
Shell	FG	Shell	FG

(2) Wiring Specifications for Cable with Connectors

SERVOPACK End		Encoder (Servomotor) End	
Pin No.	Signal	Pin No.	Wire Color
6	/PS	6	Light blue/white
5	PS	5	Light blue
4	BAT (-)	4	Orange/white
3	BAT (+)	3	Orange
2	PG 0V	2	Black
1	PG 5V	1	Red
Shell	FG	Shell	FG

(3) Wiring Specifications for Cable with a Battery Case

SERVOPACK End		Encoder (Servomotor) End	
Pin No.	Signal	Pin No.	Wire Color
6	/PS	6	Light blue/white
5	PS	5	Light blue
4	BAT (-)	4	Orange/white
3	BAT (+)	3	Orange
2	PG 0V	2	Black
1	PG 5V	1	Red
Shell	FG	Shell	FG

Battery Case	
Pin No.	Signal
2	BAT (-)
1	BAT (+)

(4) Cable Specifications

Item	Standard Type
Order No.*	JZSP-CMP19-□□-E
Cable Length	50 m max.
Specifications	UL20276 (Rating temperature: 80°C) AWG16×2C+AWG26×2P AWG16 (1.31 mm ²) Outer diameter of insulating sheath: 2.0 dia. mm AWG26 (0.13 mm ²) Outer diameter of insulating sheath: 0.91 dia. mm
Finished Dimensions	6.8 dia. mm
Internal Configuration and Lead Colors	
Yaskawa Standard Specifications (Standard Length)	Cable length: 30 m, 40 m, 50 m

*: Specify the cable length in □□ of order no.
Example: JZSP-CMP19-30-E (30 m)

With Low-backlash Gears

Ratings and Specifications

Time Rating: Continuous
Insulation Resistance: 500 VDC, 10 MΩ min.
Ambient Temperature: 0 to 40°C
Excitation: Permanent magnet
Mounting: Flange-mounted
Gear Mechanism: Planetary gear mechanism
Thermal Class: B

Withstand Voltage: 1500 VAC for one minute
Enclosure: Totally enclosed, self-cooled, IP55
 (except for shaft opening)
Ambient Humidity: 20% to 80% (no condensation)
Drive Method: Direct drive
Rotation Direction: Counterclockwise (CCW) with forward run
 reference when viewed from the load side

Servomotor Model SGMJV-	Servomotor					Gear					
	Rated Output W	Rated Speed min ⁻¹	Max. Speed min ⁻¹	Rated Torque N·m	Instantaneous Peak Torque N·m	Gear Ratio	Lost Motion arc-min	Rated Torque / Efficiency* ¹ N·m / %	Instantaneous Peak Torque N·m	Rated Speed min ⁻¹	Max. Speed min ⁻¹
A5A□AH1□	50	3000	6000	0.159	0.557	1/5	3 max.	0.433/64* ²	2.37	600	1200
A5A□AH2□						1/9		1.12/78	3.78* ³	333	667
A5A□AHC□						1/21		2.84/85	10.6	143	286
A5A□AH7□						1/33		3.68/70	15.8	91	182
01A□AH1□	100	3000	6000	0.318	1.11	1/5	3 max.	1.06/78* ²	4.96	600	1200
01A□AHB□						1/11		2.52/72	10.7	273	545
01A□AHC□						1/21		5.35/80	20.8	143	286
01A□AH7□						1/33		7.35/70	32.7	91	182
02A□AH1□	200	3000	6000	0.637	2.23	1/5	3 max.	2.39/75	9.80	600	1200
02A□AHB□						1/11		5.74/82	22.1	273	545
02A□AHC□						1/21		10.2/76	42.1	143	286
02A□AH7□						1/33		17.0/81	67.6	91	182
04A□AH1□	400	3000	6000	1.27	4.46	1/5	3 max.	5.35/84	20.1	600	1200
04A□AHB□						1/11		11.5/82	45.1	273	545
04A□AHC□						1/21		23.0/86	87.0	143	286
04A□AH7□						1/33		34.0/81	135	91	182
08A□AH1□	750	3000	6000	2.39	8.36	1/5	3 max.	10.0/84	38.4	600	1200
08A□AHB□						1/11		23.1/88	86.4	273	545
08A□AHC□						1/21		42.1/84	163	143	286
08A□AH7□						1/33		69.3/88	259	91	182

*1: Gear output torque is expressed using the following equation.

$$(\text{Gear output torque}) = (\text{Servomotor output torque}) \times \frac{1}{(\text{gear ratio})} \times (\text{efficiency})$$

Gear efficiency depends on operating conditions such as output torque, motor speed, and temperature etc. The values in the table are representative values with rated torque, rated speed, and an ambient temperature of 25°C, and are not guaranteed values.

*2: When using SGMJV-A5A, -01A servomotors with a gear ratio of 1/5, maintain an 85% max. effective load ratio. The values in the table are provided with consideration given to the effective load ratio.

*3: Instantaneous Peak torque is 300%

Notes: 1 The gear mounted to our servomotor has not been broken in. Break in the servomotor if necessary. First, run the motor at low speed with no load. If no problems arise, gradually increase the speed and load.

2 The no-load torque for a servomotor with a gear is high immediately after the servomotor starts, and it then decreases and becomes stable a few minutes later. This is a common phenomenon caused by grease being circulated in the gear and not by a faulty gear.

IMPORTANT The SERVOPACK speed control range is 5000:1. When using servomotors at extremely low speeds (0.02 min⁻¹ at gear output shaft), when using servomotors with one pulse feed reference for extended periods and in some other situations, the gear bearing lubrication may be insufficient. That may cause deterioration of bearing or increase the load ratio. Contact your Yaskawa representative if you are using your servomotor under these conditions.

With Low-backlash Gears Ratings and Specifications

● **Moment of Inertia and Allowable Radial and Thrust Loads**

Servomotor Model SGMJV-	Moment of Inertia×10 ⁻⁴ kg·m ²				Servomotors with Low-backlash Gears			Reference Diagram
	Motor + Gear	Gear	Flange Output		Allowable Radial Load (Fr) N	Allowable Thrust Load (Fs) N	LR mm	
			Motor + Gear	Gear				
A5A□AH1□	0.0474	0.006	0.0464	0.005	95	431	37	
A5A□AH2□	0.0444	0.003	0.0444	0.003	113	514	37	
A5A□AHC□	0.0454	0.004	0.0454	0.004	146	663	37	
A5A□AH7□	0.0864	0.045	0.0864	0.045	267	1246	53	
01A□AH1□	0.0725	0.006	0.0715	0.005	95	431	37	
01A□AHB□	0.127	0.060	0.126	0.059	192	895	53	
01A□AHC□	0.117	0.050	0.117	0.050	233	1087	53	
01A□AH7□	0.132	0.065	0.131	0.064	605	2581	75	
02A□AH1□	0.466	0.207	0.460	0.201	152	707	53	
02A□AHB□	0.452	0.193	0.451	0.192	192	895	53	
02A□AHC□	0.749	0.490	0.747	0.488	528	2254	75	
02A□AH7□	0.709	0.450	0.708	0.449	605	2581	75	
04A□AH1□	0.649	0.207	0.643	0.201	152	707	53	
04A□AHB□	1.01	0.570	1.00	0.560	435	1856	75	
04A□AHC□	0.932	0.490	0.930	0.488	528	2254	75	
04A□AH7□	1.06	0.620	1.05	0.610	951	4992	128	
08A□AH1□	2.27	0.700	2.23	0.660	343	1465	75	
08A□AHB□	2.17	0.600	2.16	0.590	435	1856	75	
08A□AHC□	4.57	3.00	4.55	2.98	830	4359	128	
08A□AH7□	4.37	2.80	4.36	2.79	951	4992	128	

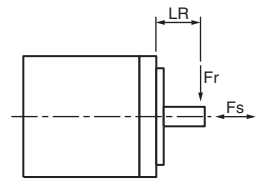

IMPORTANT

The gear generates the loss at gear mechanism and oil seal. The loss varies with torque and motor speed conditions. The temperature rise depends on heating conditions. Always check the actual gear and motor temperature. If the temperature is high, take the measures shown below.

- Decrease the load ratio.
- Change the heating conditions.
- Cool the motor with a cooling fan etc.

Rated Output W	Heat Sink Size			
	1/5	1/9 or 1/11	1/21	1/33
50	A			
100	A			
200	A			
400	B			
750	C			

A : 250 mm×250 mm×6 mm, aluminum
 B : 300 mm×300 mm×12 mm, aluminum
 C : 350 mm×350 mm×12 mm, aluminum

With Low-backlash Gears

External Dimensions Units: mm

(1) 50, 100 W

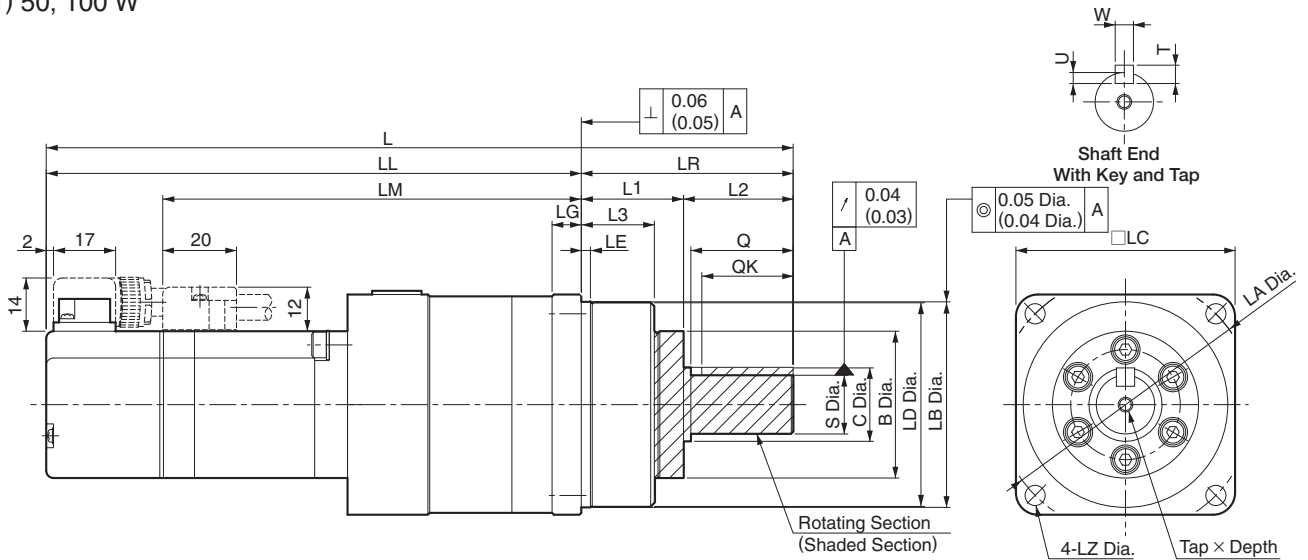

Model SGMJV-	Gear Ratio	L	LL	LM	Flange Face Dimensions								
					LR	LE	LG	B	LD	LB	LC	LA	LZ
A5A□AH1※1 (A5A□AH1※C)	1/5	150.5 (195.5)	108.5 (153.5)	76.5	42	2.2	5	29	39.5	40 ⁰ _{0.025}	40	46	3.4
A5A□AH2※1 (A5A□AH2※C)	1/9												
A5A□AHC※1 (A5A□AHC※C)	1/21	159.5 (204.5)	117.5 (162.5)	85.5									
A5A□AH7※1 (A5A□AH7※C)	1/33	191 (236)	133 (178)	101	58	2.5	8	40	55.5	56 ⁰ _{0.030}	60	70	5.5
01A□AH1※1 (01A□AH1※C)	1/5	164 (209)	122 (167)	90	42	2.2	5	29	39.5	40 ⁰ _{0.025}	40	46	3.4
01A□AHB※1 (01A□AHB※C)	1/11	204.5 (249.5)	146.5 (191.5)	114.5	58	2.5	8	40	55.5	56 ⁰ _{0.030}	60	70	5.5
01A□AHC※1 (01A□AHC※C)	1/21												
01A□AH7※1 (01A□AH7※C)	1/33	229 (274)	149 (194)	117	80	7.5	10	59	84	85 ⁰ _{0.035}	90	105	9

Model SGMJV-	Flange Face Dimensions			Q	C	S	Tap×Depth	Key Dimensions				Approx. Mass kg
	L1	L2	L3					QK	U	W	T	
A5A□AH1※1 (A5A□AH1※C)	22	20	14.6	-	-	10 ⁰ _{0.015}	M3×6L	15	2.5	4	4	0.6 (0.9)
A5A□AH2※1 (A5A□AH2※C)												
A5A□AHC※1 (A5A□AHC※C)												
A5A□AH7※1 (A5A□AH7※C)	28	30	20	28	20	16 ⁰ _{0.018}	M4×8L	25	3	5	5	1.3 (1.6)
01A□AH1※1 (01A□AH1※C)	22	20	14.6	-	-	10 ⁰ _{0.015}	M3×6L	15	2.5	4	4	0.7 (1.0)
01A□AHB※1 (01A□AHB※C)	28	30	20	28	20	16 ⁰ _{0.018}	M4×8L	25	3	5	5	1.4 (1.7)
01A□AHC※1 (01A□AHC※C)												
01A□AH7※1 (01A□AH7※C)	36	44	26	42	32	25 ⁰ _{0.021}	M6×12L	36	4	8	7	2.8 (3.1)

※: The asterisk (*) describes the values of the 8th digit of the model designation, "shaft end code 6 (straight with key and tap)." If a key or tap is not necessary, order a servomotor with "shaft end code 2 (without key and tap)."

Notes: 1 The models and values in parentheses are for servomotors with holding brakes.

2 Please note that gear dimensions are different from those of Σ-I, Σ-II, and Σ-III series.

With Low-backlash Gears External Dimensions Units: mm

● Flange Output Face

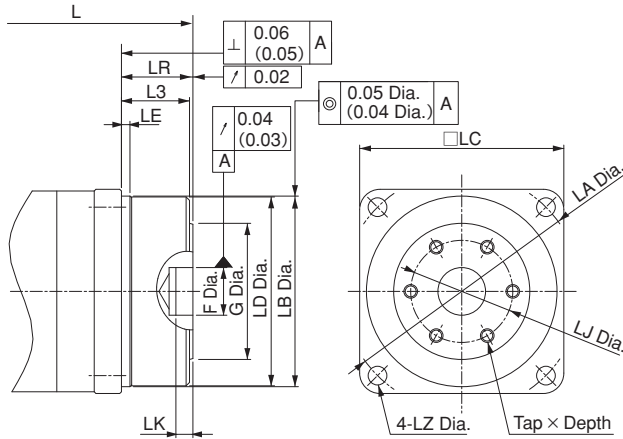

Model SGMJV-	Gear Ratio	L	LR	LJ	F	G	LK	No. of pcs Tap x Depth	Approx. Mass kg
A5A□AH101 (A5A□AH10C)	1/5	123.5 (168.5)							
A5A□AH201 (A5A□AH20C)	1/9	123.5 (168.5)	15	18	$5^{+0.012}_0$	24	3	3-M4 x 6L	0.6 (0.9)
A5A□AHC01 (A5A□AHC0C)	1/21	132.5 (177.5)							
A5A□AH701 (A5A□AH70C)	1/33	154 (199)	21	30	$14^{+0.018}_0$	40	5	6-M4 x 7L	1.2 (1.5)
01A□AH101 (01A□AH10C)	1/5	137 (182)	15	18	$5^{+0.012}_0$	24	3	3-M4 x 6L	0.7 (1.0)
01A□AHB01 (01A□AHB0C)	1/11	167.5 (212.5)							
01A□AHC01 (01A□AHC0C)	1/21	167.5 (212.5)	21	30	$14^{+0.018}_0$	40	5	3-M4 x 7L	1.3 (1.6)
01A□AH701 (01A□AH70C)	1/33	176 (221)	27	45	$24^{+0.021}_0$	59	5	6-M6 x 10L	2.4 (2.7)

Notes: 1 The models and values in parentheses are for servomotors with holding brakes.
2 Dimensions not found in the table above are the same as those in the table on the previous page.

IMPORTANT

Regarding the flange output type shaft end, when the flange "LC" is 40 mm, we recommend designing a servomotor with the dimensions shown in the diagram on the right, in order to secure the gap between the gear oil seal and the parts on the load side.

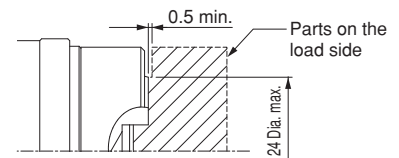

With Low-backlash Gears

External Dimensions Units: mm

(2) 200, 400 W

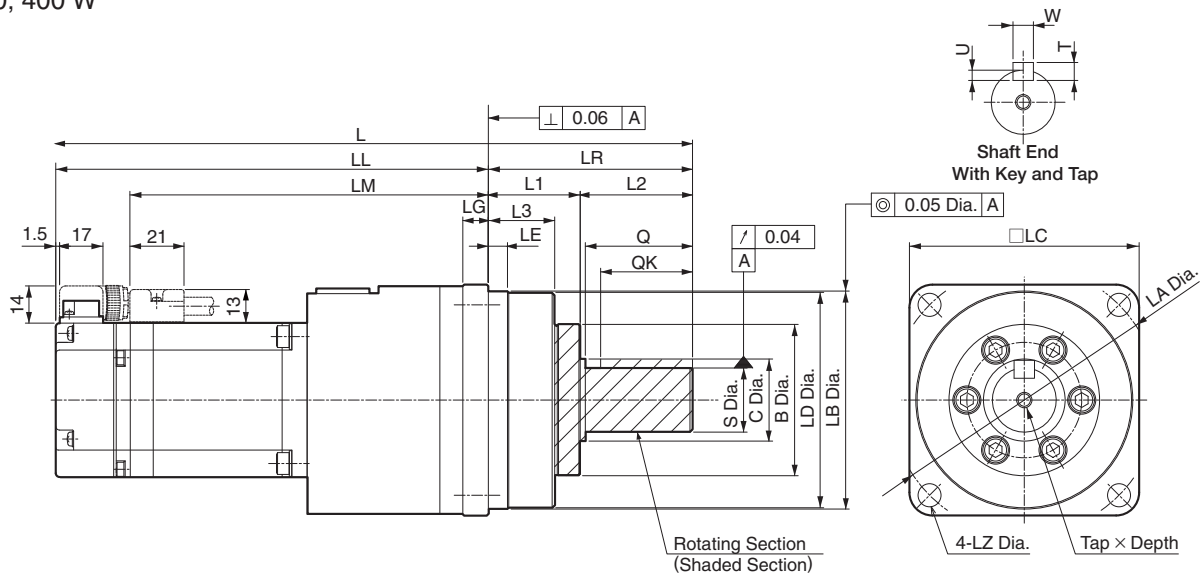

Model SGMJV-	Gear Ratio	L	LL	LM	Flange Face Dimensions								
					LR	LE	LG	B	LD	LB	LC	LA	LZ
02A□AH1※1 (02A□AH1※C)	1/5	202 (242)	144 (184)	115	58	2.5	8	40	55.5	56 ⁰ _{-0.030}	60	70	5.5
02A□AHB※1 (02A□AHB※C)	1/11												
02A□AHC※1 (02A□AHC※C)	1/21	231 (271)	151 (191)	122	80	7.5	10	59	84	85 ⁰ _{-0.035}	90	105	9
02A□AH7※1 (02A□AH7※C)	1/33												
04A□AH1※1 (04A□AH1※C)	1/5	220.5 (260.5)	162.5 (202.5)	133.5	58	2.5	8	40	55.5	56 ⁰ _{-0.030}	60	70	5.5
04A□AHB※1 (04A□AHB※C)	1/11												
04A□AHC※1 (04A□AHC※C)	1/21	249.5 (289.5)	169.5 (209.5)	140.5	80	7.5	10	59	84	85 ⁰ _{-0.035}	90	105	9
04A□AH7※1 (04A□AH7※C)	1/33												
04A□AH7※1 (04A□AH7※C)	1/33	335.5 (375.5)	202.5 (242.5)	173.5	133	12.5	13	84	114	115 ⁰ _{-0.035}	120	135	11

Model SGMJV-	Flange Face Dimensions			Q	C	S	Tap×Depth	Key Dimensions				Approx. Mass kg
	L1	L2	L3					QK	U	W	T	
02A□AH1※1 (02A□AH1※C)	28	30	20	28	20	16 ⁰ _{-0.018}	M4×8L	25	3	5	5	1.9 (2.5)
02A□AHB※1 (02A□AHB※C)												2.0 (2.6)
02A□AHC※1 (02A□AHC※C)	36	44	26	42	32	25 ⁰ _{-0.021}	M6×12L	36	4	8	7	3.8 (4.4)
02A□AH7※1 (02A□AH7※C)												
04A□AH1※1 (04A□AH1※C)	28	30	20	28	20	16 ⁰ _{-0.018}	M4×8L	25	3	5	5	2.3 (2.9)
04A□AHB※1 (04A□AHB※C)												36
04A□AHC※1 (04A□AHC※C)												
04A□AH7※1 (04A□AH7※C)	48	85	33	82	44	40 ⁰ _{-0.025}	M10×20L	70	5	12	8	8.8 (9.4)

: The asterisk () describes the values of the 8th digit of the model designation, "shaft end code 6 (straight with key and tap)." If a key or tap is not necessary, order a servomotor with "shaft end code 2 (without key and tap)."
 Notes: 1 The models and values in parentheses are for servomotors with holding brakes.
 2 Please note that gear dimensions are different from those of Σ-I, Σ-II, and Σ-III series.

With Low-backlash Gears External Dimensions Units: mm

● Flange Output Face

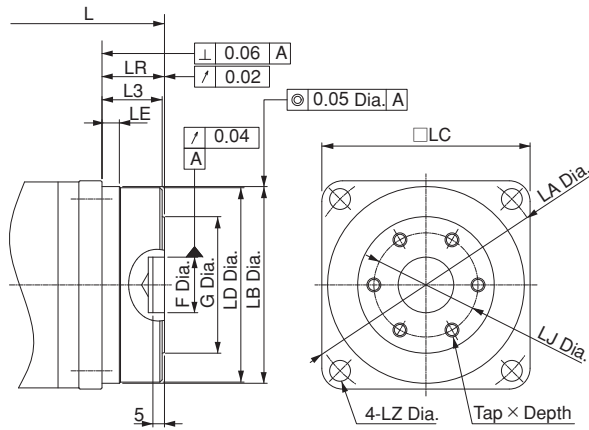

Model SGMJV-	Gear Ratio	L	LR	LJ	F	G	No. of pcs Tap x Depth	Approx. Mass kg
02A□AH101 (02A□AH10C)	1/5	165 (205)	21	30	14 ^{+0.018} ₀	40	6-M4×7L	1.8 (2.4)
02A□AHB01 (02A□AHB0C)	1/11							1.9 (2.5)
02A□AHC01 (02A□AHC0C)	1/21	178 (218)	27	45	24 ^{+0.021} ₀	59	6-M6×10L	3.4 (4.0)
02A□AH701 (02A□AH70C)	1/33							
04A□AH101 (04A□AH10C)	1/5	183.5 (223.5)	21	30	14 ^{+0.018} ₀	40	6-M4×7L	2.2 (2.8)
04A□AHB01 (04A□AHB0C)	1/11	196.5 (236.5)	27	45	24 ^{+0.021} ₀	59	6-M6×10L	3.8 (4.4)
04A□AHC01 (04A□AHC0C)	1/21							
04A□AH701 (04A□AH70C)	1/33	237.5 (277.5)	35	60	32 ^{+0.025} ₀	84	6-M8×12L	7.4 (8.0)

Notes: 1 The models and values in parentheses are for servomotors with holding brakes.
 2 Dimensions not found in the table above are the same as those in the table on the previous page.

(3) 750 W

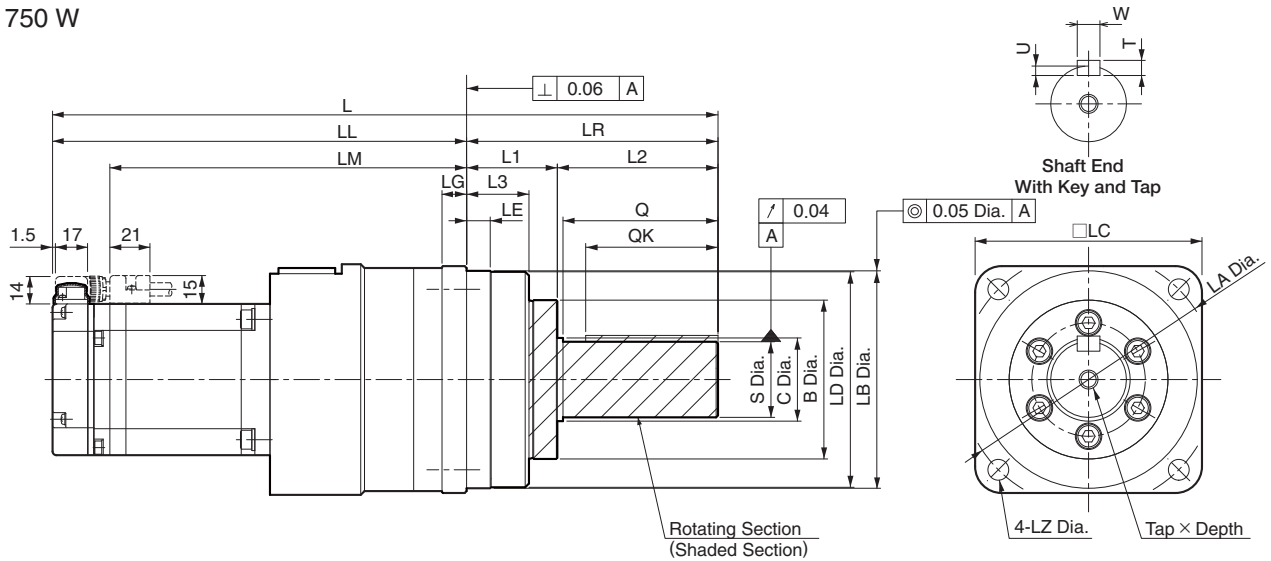

Model SGMJV-	Gear Ratio	L	LL	LM	Flange Face Dimensions								
					LR	LE	LG	B	LD	LB	LC	LA	LZ
08A□AH1※1 (08A□AH1※C)	1/5	273 (318)	193 (238)	163	80	7.5	10	59	84	85 ⁰ _{-0.035}	90	105	9
08A□AHB※1 (08A□AHB※C)	1/11												
08A□AHC※1 (08A□AHC※C)	1/21	352 (397)	219 (264)	189	133	12.5	13	84	114	115 ⁰ _{-0.035}	120	135	11
08A□AH7※1 (08A□AH7※C)	1/33												

Model SGMJV-	Flange Face Dimensions			Q	C	S	Tap×Depth	Key Dimensions				Approx. Mass kg
	L1	L2	L3					QK	U	W	T	
08A□AH1※1 (08A□AH1※C)	36	44	26	42	32	25 ⁰ _{-0.021}	M6×12L	36	4	8	7	5.6 (6.5)
08A□AHB※1 (08A□AHB※C)												5.8 (6.7)
08A□AHC※1 (08A□AHC※C)	48	85	33	82	44	40 ⁰ _{-0.025}	M10×20L	70	5	12	8	10.5 (11.4)
08A□AH7※1 (08A□AH7※C)												

※: The asterisk (*) describes the values of the 8th digit of the model designation, "shaft end code 6 (straight with key and tap)." If a key or tap is not necessary, order a servomotor with "shaft end code 2 (without key and tap)."

Notes: 1 The models and values in parentheses are for servomotors with holding brakes.

2 Please note that gear dimensions are different from those of Σ-I, Σ-II, and Σ-III series.

With Low-backlash Gears External Dimensions Units: mm

● Flange Output Face

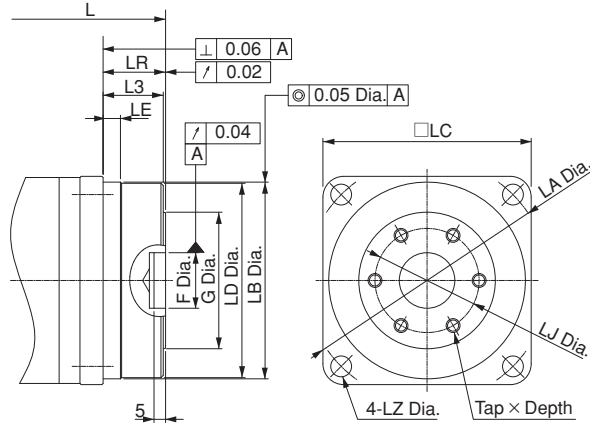

Model SGMJV-	Gear Ratio	L	LR	LJ	F	G	No. of pcs Tap x Depth	Approx. Mass kg
08A□AH101 (08A□AH10C)	1/5	220 (265)	27	45	24 ^{+0.021} ₀	59	6-M6×10L	5.2 (6.1)
08A□AHB01 (08A□AHB0C)	1/11							5.4 (6.3)
08A□AHC01 (08A□AHC0C)	1/21	254 (299)	35	60	32 ^{+0.025} ₀	84	6-M8×12L	9.1 (10.0)
08A□AH701 (08A□AH70C)	1/33							

Notes: 1 The models and values in parentheses are for servomotors with holding brakes.
2 Dimensions not found in the table above are the same as those in the table on the previous page.

Rotary Servomotors

SGMAV



Model Designations

● Without Gears

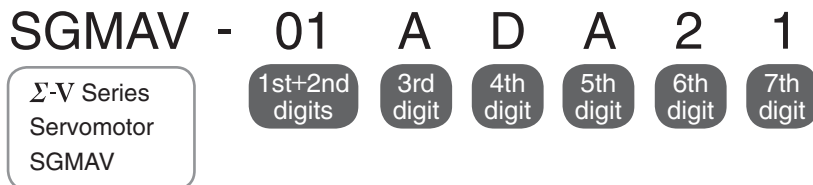

1st+2nd digits Rated Output

Code	Specifications
A5	50 W
01	100 W
C2	150 W
02	200 W
04	400 W
06	550 W
08	750 W
10	1.0 kW

3rd digit Power Supply Voltage

Code	Specifications
A	200 VAC

4th digit Serial Encoder

Code	Specifications
3	20-bit absolute (standard)*
D	20-bit incremental (standard)

5th digit Design Revision Order

Code	Specifications
A	Standard

6th digit Shaft End

Code	Specifications
2	Straight without key (standard)
6	Straight with key and tap (optional)
B	With two flat seats (optional)

7th digit Options

Code	Specifications
1	Without options
C	With holding brake (24 VDC)
E	With oil seal and holding brake (24 VDC)
S	With oil seal

*: When exporting the servomotors themselves, export restrictions may apply. Follow each country's export restrictions.

Features

- Super high power rate (Extremely low inertia)
- Instantaneous peak torque (300% of rated torque)
- Mounted high-resolution serial encoder: 20 bits
- Maximum speed: 6,000 min⁻¹
- Wide selection: 50 W to 1.0 kW capacity, holding brake and gear options

Application Examples

- Semiconductor equipment
- Chip mounters
- PCB drilling stations
- Robots
- Material handling machines
- Food processing equipment

● With Gears



1st+2nd digits Rated Output

Code	Specifications
A5	50 W
01	100 W
C2	150 W
02	200 W
04	400 W
06	550 W
08	750 W
10	1.0 kW

3rd digit Power Supply Voltage

Code	Specifications
A	200 VAC

4th digit Serial Encoder

Code	Specifications
3	20-bit absolute (standard)*
D	20-bit incremental (standard)

5th digit Design Revision Order

Code	Specifications
A	Standard

6th digit Gear Type

Code	Specifications
H	HDS planetary low-backlash gear

7th digit Gear Ratio

Code	Specifications
B	1/11 (Not available: 50 W)
C	1/21
1	1/5
2	1/9 (Only 50 W)
7	1/33

8th digit Shaft End

Code	Specifications
0	Flange output
2	Straight without key
6	Straight with key and tap

9th digit Options

Code	Specifications
1	Without options
C	With holding brake (24 VDC)

*: When exporting the servomotors themselves, export restrictions may apply. Follow each country's export restrictions.

Ratings and Specifications

Time Rating: Continuous
Vibration Class: V15
Insulation Resistance: 500 VDC, 10 MΩ min.
Ambient Temperature: 0 to 40°C
Excitation: Permanent magnet
Mounting: Flange-mounted
Thermal Class: B

Withstand Voltage: 1500 VAC for one minute
Enclosure: Totally enclosed, self-cooled, IP65
 (except for shaft opening)
Ambient Humidity: 20% to 80% (no condensation)
Drive Method: Direct drive
Rotation Direction: Counterclockwise (CCW) with forward run
 reference when viewed from the load side

Voltage		200 V							
Servomotor Model: SGMVA-□□□		A5A	01A	C2A	02A	04A	06A	08A	10A
Rated Output*1	W	50	100	150	200	400	550	750	1000
Rated Torque*1, *2	N·m	0.159	0.318	0.477	0.637	1.27	1.75	2.39	3.18
Instantaneous Peak Torque*1	N·m	0.477	0.955	1.43	1.91	3.82	5.25	7.16	9.55
Rated Current*1	Arms	0.66	0.91	1.3	1.5	2.6	3.8	5.3	7.4
Instantaneous Max. Current*1	Arms	2.1	2.8	4.2	5.3	8.5	12.2	16.6	23.9
Rated Speed*1	min ⁻¹	3000							
Max. Speed*1	min ⁻¹	6000							
Torque Constant	N·m/Arms	0.265	0.375	0.381	0.450	0.539	0.496	0.487	0.467
Rotor Moment of Inertia	× 10 ⁻⁴ kg·m ²	0.0242 (0.0389)	0.0380 (0.0527)	0.0531 (0.0678)	0.116 (0.180)	0.190 (0.254)	0.326 (0.403)	0.769 (0.940)	1.20 (1.41)
Rated Power Rate*1	kW/s	10.4	26.6	42.8	35.0	84.9	93.9	74.1	84.3
Rated Angular Acceleration*1	rad/s ²	65800	83800	89900	54900	67000	53700	31000	26500
Applicable SERVOPACK	SGDV-□□□□	R70□	R90□	1R6A,2R1F		2R8□	5R5A	5R5A	120A

*1: These items and torque-motor speed characteristics quoted in combination with an SGDV SERVOPACK are at an armature winding temperature of 100°C. Other values quoted are at 20°C.

*2: Rated torques are continuous allowable torque values at 40°C with an aluminum heat sink of the following dimensions attached.

SGMVA-A5A, -01A: 200 mm×200 mm×6 mm
 SGMVA-C2A, -02A, -04A, -06A, -08A: 250 mm×250 mm×6 mm
 SGMVA-10A: 300 mm×300 mm×12 mm

Note: The values in parentheses are for servomotors with holding brakes.

● Torque-Motor Speed Characteristics A: Continuous Duty Zone B: Intermittent Duty Zone^(Note3)

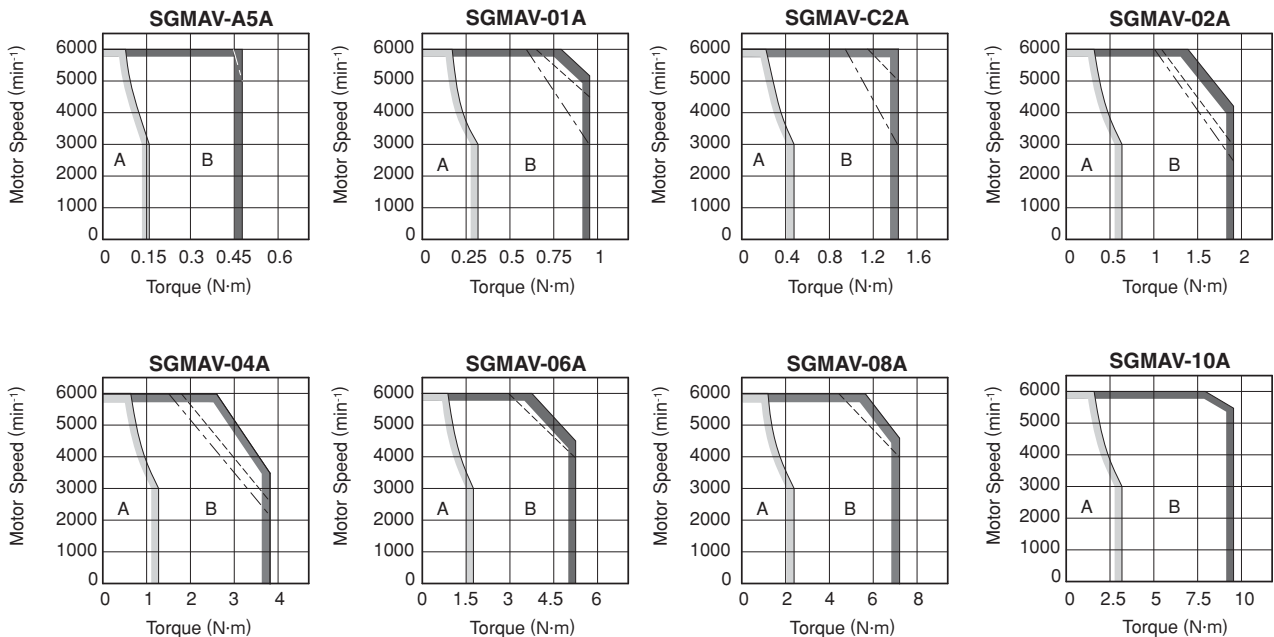

Notes: 1 The solid, dotted, and dashed-dotted lines of the intermittent duty zone indicate the characteristics when a servomotor runs with the following combinations:

- The solid line: With a three-phase 200 V or a single-phase 230 V SERVOPACK
- The dotted line: With a single-phase 200 V SERVOPACK
- The dashed-dotted line: With a single-phase 100 V SERVOPACK

An SGMVA-A5A servomotor has the same characteristics in combination with three-phase 200 V and single-phase 200 V SERVOPACKs.

2 The characteristics of the intermittent duty zone differ depending on the supply voltages.

3 When the effective torque during intermittent duty is within the rated torque, the servomotor can be used within the intermittent duty zone.

4 When the main circuit cable length exceeds 20 m, note that the intermittent duty zone of the *Torque-Motor Speed Characteristics* will shrink as the line-to-line voltage drops.

Ratings and Specifications

● Derating Rate for Servomotor Fitted with an Oil Seal

When a motor is fitted with an oil seal, use the following derating rate because of the higher friction torque.

Servomotor Model SGMAV-	A5A	01A	C2A	02A	04A	06A	08A	10A
Derating Rate %	80	90			95			

● Holding Brake Electrical Specifications

Holding Brake Rated Voltage	Servomotor Model	Servomotor Rated Output W	Holding Brake Specifications					
			Capacity W	Holding Torque N·m	Coil Resistance Ω (at 20°C)	Rated Current A(at 20°C)	Brake Release Time ms	Brake Operation Time ms
24 VDC ^{+10%} ₀	SGMAV-A5A	50	5.5	0.159	103	0.23	60	100
	SGMAV-01A	100		0.318				
	SGMAV-C2A	150	5.1	0.477	114	0.21	60	100
	SGMAV-02A	200	6	0.637	97.4	0.25	60	100
	SGMAV-04A	400		1.27				
	SGMAV-06A	550	8	1.75	74.3	0.32	80	100
	SGMAV-08A	750	6.5	2.39	87.7	0.27	80	100
	SGMAV-10A	1000	7	3.18	82.8	0.29	80	100

- Notes: 1 The holding brake is only used to hold the load and cannot be used to stop the servomotor.
 2 The holding brake open time and holding brake operation time vary depending on which discharge circuit is used. Make sure holding brake open time and holding brake operation time are correct for your servomotor.
 3 A 24-VDC power supply is provided by customers.

● Overload Characteristics

The overload detection level is set under hot start conditions at a servomotor ambient temperature of 40°C.

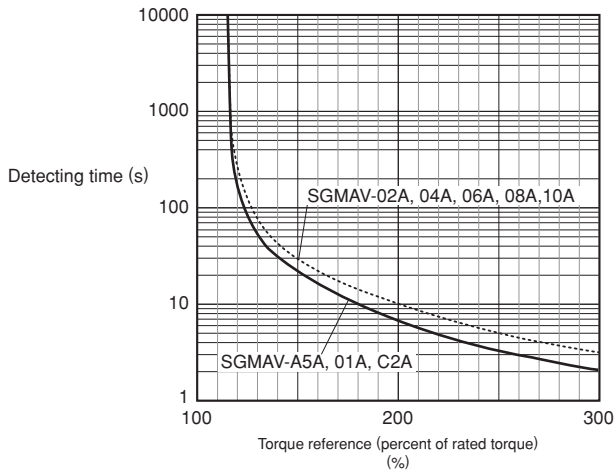

Note: Overload characteristics shown above do not guarantee continuous duty of 100% or more output. Use a servomotor with effective torque within the continuous duty zone of *Torque-Motor Speed Characteristics*.

Ratings and Specifications

● Allowable Load Moment of Inertia at the Motor Shaft

The rotor moment of inertia ratio is the value for a servomotor without a gear and a brake.

Servomotor Model		Servomotor Rated Output	Allowable Load Moment of Inertia (Rotor Moment of Inertia Ratio)
SGMAV-	A5A, 01A, C2A, 02A	50 to 200 W	30 times
	04A, 06A, 08A	400 to 750 W	20 times
	10A	1000 W	10 times

● Load Moment of Inertia

The larger the load moment of inertia, the worse the movement response.

The allowable load moment of inertia (J_L) depends on the motor capacity, as shown above. This value is provided strictly as a guideline and results may vary depending on servomotor drive conditions.

Use the AC servo drive capacity selection program SigmaJunmaSize+ to check the operation conditions. The program can be downloaded for free from our web site (<http://www.e-mechatronics.com/>).

An overvoltage alarm (A.400) is likely to occur during deceleration if the load moment of inertia exceeds the allowable load moment of inertia. SERVOPACKs with a built-in regenerative resistor may generate a regenerative overload alarm (A.320). Take one of the following steps if this occurs.

- Reduce the torque limit.
- Reduce the deceleration rate.
- Reduce the maximum speed.
- Install an external regenerative resistor if the alarm cannot be cleared using the steps above. Refer to *Regenerative Resistors* on page 360.

Regenerative resistors are not built into SERVOPACKs for 400 W motors or less.

External regenerative resistors are required when this condition is exceeded or if the allowable loss capacity (W) of the built-in regenerative resistor is exceeded due to regenerative drive conditions when a regenerative resistor is already built in.

● Allowable Radial and Thrust Loads

Design the mechanical system so thrust and radial loads applied to the servomotor shaft end during operation fall within the ranges shown in the table.

Servomotor Model		Allowable Radial Load (F_r) N	Allowable Thrust Load (F_s) N	LR mm	Reference Diagram
SGMAV-	A5A	78	54	20	
	01A				
	C2A				
	02A	245	74	25	
	04A				
	06A				
	08A				
	10A	392	147	35	

External Dimensions Units: mm

(1) 50 to 150 W

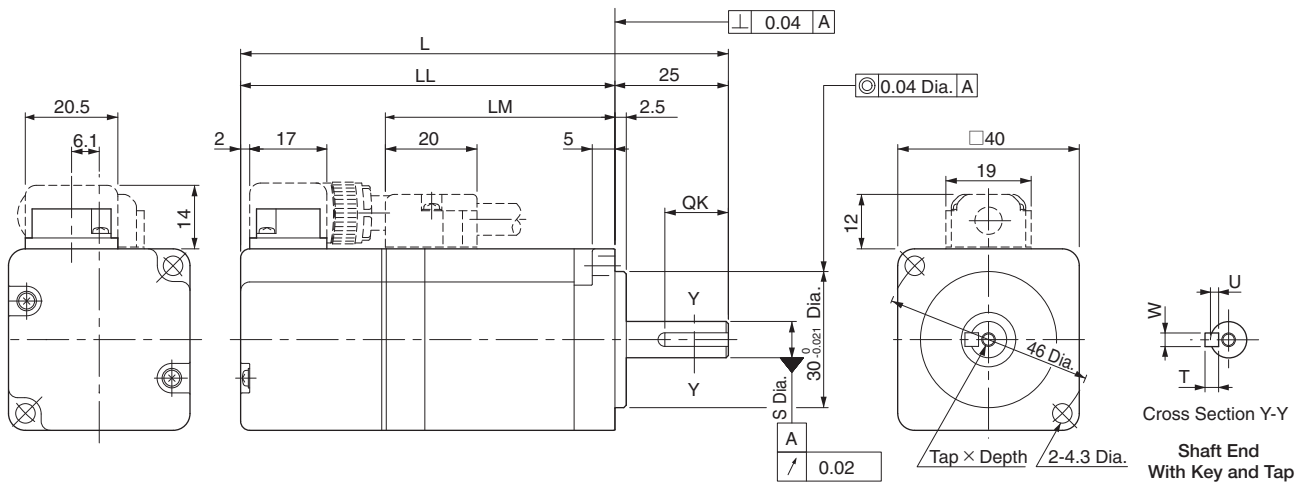

Model SGMAV-	L	LL	LM	S	Tap×Depth	Key Dimensions				Approx. Mass kg
						QK	U	W	T	
A5A□A21 (A5A□A2C)	95.5 (140.5)	70.5 (115.5)	38.5	$8_{-0.009}^0$ *	No tap	No key				0.3 (0.6)
M3×6L					14	1.8	3	3		
A5A□A61 (A5A□A6C)										
01A□A21 (01A□A2C)	107.5 (152.5)	82.5 (127.5)	50.5	$8_{-0.009}^0$	No tap	No key				0.4 (0.7)
M3×6L					14	1.8	3	3		
01A□A61 (01A□A6C)										
C2A□A21 (C2A□A2C)	119.5 (164.5)	94.5 (139.5)	62.5	$8_{-0.009}^0$	No tap	No key				0.5 (0.8)
M3×6L					14	1.8	3	3		
C2A□A61 (C2A□A6C)										

Note: The models and values in parentheses are for servomotors with holding brakes.

*: When you need the same shaft diameter as the conventional servomotors, contact your Yaskawa representative.

〈Shaft End and Other Options〉

●With Two Flat Seats

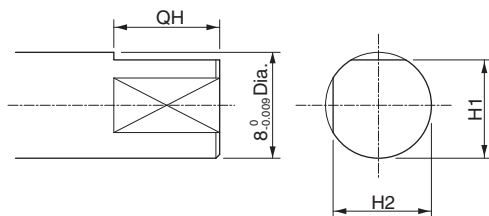

Model SGMAV-	Dimensions of Servomotor with Two Flat Seats		
	QH	H1	H2
A5A□AB□	15	7.5	7.5
01A□AB□			
C2A□AB□			

●With an Oil Seal

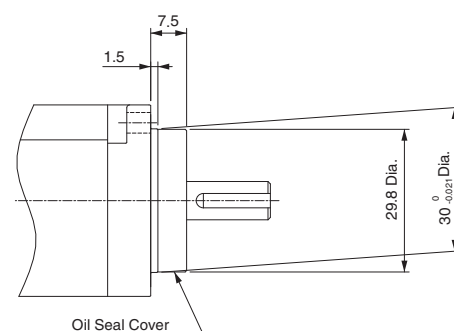

Note: The 7th digit of the model designation is "S" or "E."
The key dimensions are the same as those in the table above.

External Dimensions Units: mm

(2) 200 W to 1.0 kW

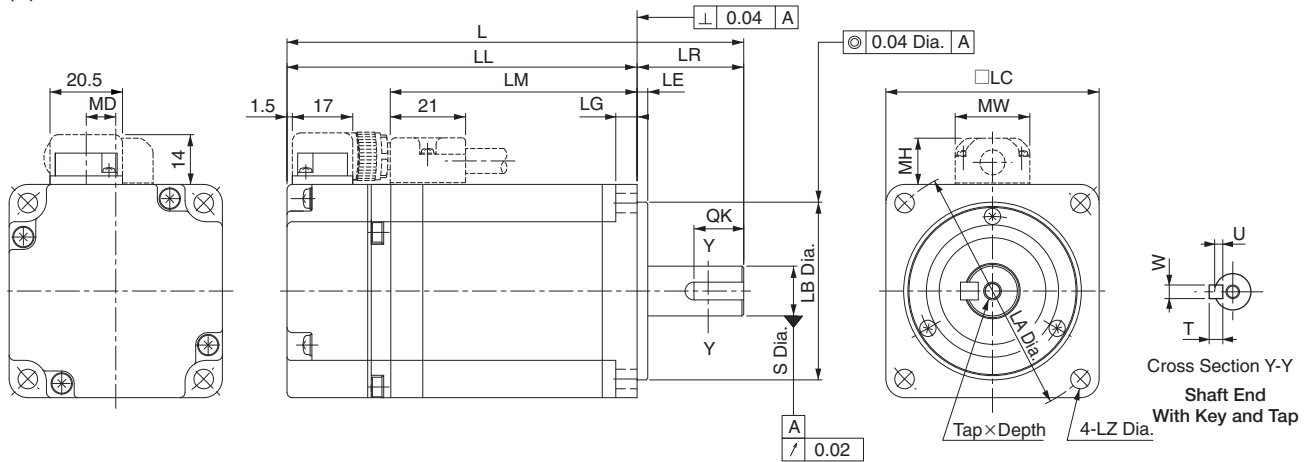

Model SGMAV-	L	LL	LM	Flange Face Dimensions								S	Tap x Depth	Key Dimensions				MD	MW	MH	Approx. Mass kg
				LR	LE	LG	LC	LA	LB	LZ	QK			U	W	T					
02A□A21 (02A□A2C)	110 (150)	80 (120)	51	30	3	6	60	70	50 ⁰ _{-0.025}	5.5	14 ⁰ _{-0.011}	No tap	No key				8.5	21	13	0.9 (1.5)	
02A□A61 (02A□A6C)												M5×8L	14	3	5	5					
04A□A21 (04A□A2C)	128.5 (168.5)	98.5 (138.5)	69.5	30	3	6	60	70	50 ⁰ _{-0.025}	5.5	14 ⁰ _{-0.011}	No tap	No key				8.5	21	13	1.2 (1.8)	
04A□A61 (04A□A6C)												M5×8L	14	3	5	5					
06A□A21 (06A□A2C)	154.5 (200.5)	124.5 (170.5)	95.5	30	3	6	60	70	50 ⁰ _{-0.025}	5.5	14 ⁰ _{-0.011}	No tap	No key				8.5	21	13	1.7 (2.4)	
06A□A61 (06A□A6C)												M5×8L	14	3	5	5					
08A□A21 (08A□A2C)	155 (200)	115 (160)	85	40	3	8	80	90	70 ⁰ _{-0.030}	7	19 ⁰ _{-0.013} *	No tap	No key				13.8	27	15	2.6 (3.2)	
08A□A61 (08A□A6C)												M6×10L	22	3.5	6	6					
10A□A21 (10A□A2C)	185 (235)	145 (195)	115	40	3	8	80	90	70 ⁰ _{-0.030}	7	19 ⁰ _{-0.013} *	No tap	No key				13.8	27	15	3.6 (4.6)	
10A□A61 (10A□A6C)												M6×10L	22	3.5	6	6					

Note: The models and values in parentheses are for servomotors with holding brakes.

*: When you need the same shaft diameter as the conventional servomotors, contact your Yaskawa representative.

<Shaft End and Other Options>

● With Two Flat Seats

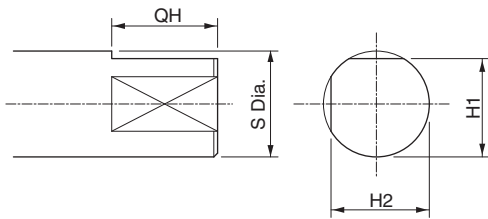

Model SGMAV-	Dimensions of Servomotor with Two Flat Seats			
	QH	S	H1	H2
02A□AB□	14	14 ⁰ _{-0.011}	13	13
04A□AB□				
06A□AB□				
08A□AB□	22	19 ⁰ _{-0.013}	18	18
10A□AB□				

● With an Oil Seal

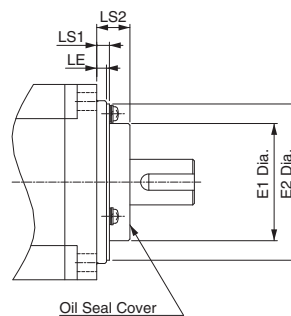

Model SGMAV-	Dimensions of Servomotor with an Oil Seal			
	E1	E2	LS1	LS2
02A, 04A, 06A	36	48	4	10
08A, 10A	49	66	6	11

Note: The 7th digit of the model designation is "S" or "E."

The key dimensions are the same as those in the table above.

Selecting Cables

● Cables Connections

- Standard Wiring (Max. encoder cable length: 20 m)

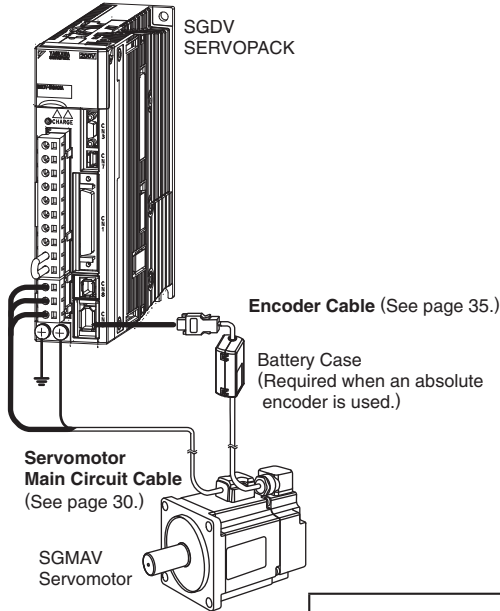

- Encoder Cable Extension from 30 to 50 m (Example) (See page 37.)

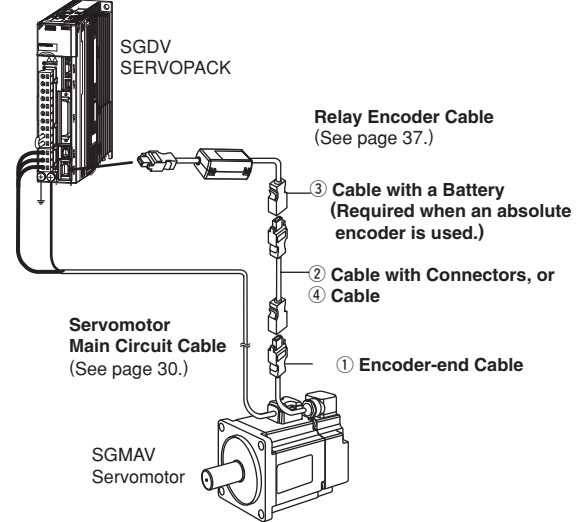

⚠ CAUTION



- Separate the servomotor main circuit cable wiring from the I/O signal cable and encoder cable at least 30 cm, and do not bundle or run them in the same duct.
- When the cable length exceeds 20 m, be sure to use a relay encoder cable.
- When the main circuit cable length exceeds 20 m, note that the intermittent duty zone of the *Torque-Motor Speed Characteristics* will shrink as the line-to-line voltage drops.

● Servomotor Main Circuit Cable

Name	Servomotor Rated Output	Length	Order No.		Specifications	Details
			Standard Type	Flexible Type*		
For Servomotor without Holding Brakes	50 to 150 W	3 m	JZSP-CSM01-03-E	JZSP-CSM21-03-E		(1)
		5 m	JZSP-CSM01-05-E	JZSP-CSM21-05-E		
		10 m	JZSP-CSM01-10-E	JZSP-CSM21-10-E		
		15 m	JZSP-CSM01-15-E	JZSP-CSM21-15-E		
		20 m	JZSP-CSM01-20-E	JZSP-CSM21-20-E		
		30 m	JZSP-CSM01-30-E	JZSP-CSM21-30-E		
		40 m	JZSP-CSM01-40-E	JZSP-CSM21-40-E		
		50 m	JZSP-CSM01-50-E	JZSP-CSM21-50-E		
	200 to 550 W	3 m	JZSP-CSM02-03-E	JZSP-CSM22-03-E		
		5 m	JZSP-CSM02-05-E	JZSP-CSM22-05-E		
		10 m	JZSP-CSM02-10-E	JZSP-CSM22-10-E		
		15 m	JZSP-CSM02-15-E	JZSP-CSM22-15-E		
		20 m	JZSP-CSM02-20-E	JZSP-CSM22-20-E		
		30 m	JZSP-CSM02-30-E	JZSP-CSM22-30-E		
		40 m	JZSP-CSM02-40-E	JZSP-CSM22-40-E		
		50 m	JZSP-CSM02-50-E	JZSP-CSM22-50-E		
	750 W, 1.0 kW	3 m	JZSP-CSM03-03-E	JZSP-CSM23-03-E		
		5 m	JZSP-CSM03-05-E	JZSP-CSM23-05-E		
		10 m	JZSP-CSM03-10-E	JZSP-CSM23-10-E		
		15 m	JZSP-CSM03-15-E	JZSP-CSM23-15-E		
		20 m	JZSP-CSM03-20-E	JZSP-CSM23-20-E		
		30 m	JZSP-CSM03-30-E	JZSP-CSM23-30-E		
		40 m	JZSP-CSM03-40-E	JZSP-CSM23-40-E		
		50 m	JZSP-CSM03-50-E	JZSP-CSM23-50-E		

(Cont'd)

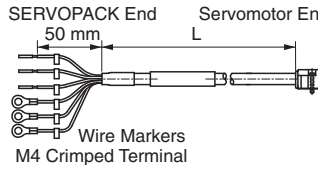
Selecting Cables

Name	Servomotor Rated Output	Length	Order No.		Specifications	Details
			Standard Type	Flexible Type*		
For Servomotor with Holding Brakes	50 to 150 W	3 m	JZSP-CSM11-03-E	JZSP-CSM31-03-E	 <p>SERVOPACK End Servomotor End</p> <p>50 mm L</p> <p>Wire Markers M4 Crimped Terminal</p>	(2)
		5 m	JZSP-CSM11-05-E	JZSP-CSM31-05-E		
		10 m	JZSP-CSM11-10-E	JZSP-CSM31-10-E		
		15 m	JZSP-CSM11-15-E	JZSP-CSM31-15-E		
		20 m	JZSP-CSM11-20-E	JZSP-CSM31-20-E		
		30 m	JZSP-CSM11-30-E	JZSP-CSM31-30-E		
		40 m	JZSP-CSM11-40-E	JZSP-CSM31-40-E		
	50 m	JZSP-CSM11-50-E	JZSP-CSM31-50-E			
	200 to 550 W	3 m	JZSP-CSM12-03-E	JZSP-CSM32-03-E		
		5 m	JZSP-CSM12-05-E	JZSP-CSM32-05-E		
		10 m	JZSP-CSM12-10-E	JZSP-CSM32-10-E		
		15 m	JZSP-CSM12-15-E	JZSP-CSM32-15-E		
		20 m	JZSP-CSM12-20-E	JZSP-CSM32-20-E		
		30 m	JZSP-CSM12-30-E	JZSP-CSM32-30-E		
		40 m	JZSP-CSM12-40-E	JZSP-CSM32-40-E		
	50 m	JZSP-CSM12-50-E	JZSP-CSM32-50-E			
	750 W, 1.0 kW	3 m	JZSP-CSM13-03-E	JZSP-CSM33-03-E		
		5 m	JZSP-CSM13-05-E	JZSP-CSM33-05-E		
		10 m	JZSP-CSM13-10-E	JZSP-CSM33-10-E		
		15 m	JZSP-CSM13-15-E	JZSP-CSM33-15-E		
		20 m	JZSP-CSM13-20-E	JZSP-CSM33-20-E		
30 m		JZSP-CSM13-30-E	JZSP-CSM33-30-E			
40 m		JZSP-CSM13-40-E	JZSP-CSM33-40-E			
50 m	JZSP-CSM13-50-E	JZSP-CSM33-50-E				
Servomotor-end Connector Kit	50 to 150 W	JZSP-CSM9-1-E		Crimping Type (A crimp tool is required.) 	(3)	
	200 to 550 W	JZSP-CSM9-2-E			(4)	
	750 W, 1.0 kW	JZSP-CSM9-3-E			(5)	
Cables	50 to 550 W	5 m	JZSP-CSM90-05-E	JZSP-CSM80-05-E		(6)
		10 m	JZSP-CSM90-10-E	JZSP-CSM80-10-E		
		15 m	JZSP-CSM90-15-E	JZSP-CSM80-15-E		
		20 m	JZSP-CSM90-20-E	JZSP-CSM80-20-E		
		30 m	JZSP-CSM90-30-E	JZSP-CSM80-30-E		
		40 m	JZSP-CSM90-40-E	JZSP-CSM80-40-E		
		50 m	JZSP-CSM90-50-E	JZSP-CSM80-50-E		
	750 W, 1.0kW	5 m	JZSP-CSM91-05-E	JZSP-CSM81-05-E		(7)
		10 m	JZSP-CSM91-10-E	JZSP-CSM81-10-E		
		15 m	JZSP-CSM91-15-E	JZSP-CSM81-15-E		
		20 m	JZSP-CSM91-20-E	JZSP-CSM81-20-E		
		30 m	JZSP-CSM91-30-E	JZSP-CSM81-30-E		
		40 m	JZSP-CSM91-40-E	JZSP-CSM81-40-E		
		50 m	JZSP-CSM91-50-E	JZSP-CSM81-50-E		

*: Use flexible cables for movable sections such as robot arms.

Selecting Cables

(1) Wiring Specifications for Servomotors without Holding Brakes (2) Wiring Specifications for Servomotor with Holding Brakes

SERVOPACK-end Leads		Servomotor-end Connector	
Wire Color	Signal	Signal	Pin No.
Green/yellow	FG	FG	1
Blue	Phase W	Phase W	2
White	Phase V	Phase V	3
Red	Phase U	Phase U	4
		-	5
		-	6

SERVOPACK-end Leads		Servomotor-end Connector	
Wire Color	Signal	Signal	Pin No.
Green/yellow	FG	FG	1
Blue	Phase W	Phase W	2
White	Phase V	Phase V	3
Red	Phase U	Phase U	4
Black	Brake	Brake	5
Black	Brake	Brake	6

Note: No polarity for connection to a holding brake.

(3) Servomotor-end Connector Kit Specifications: For 50 to 150 W Servomotors

Items	Specifications	External Dimensions mm
Order No.	JZSP-CSM9-1-E (Cables are not included.)	
Applicable Servomotors	SGMAV-A5A, -01A, -C2A	
Manufacturer	J.S.T. Mfg. Co., Ltd.	
Receptacle	J17-06FMH-7KL-1-CF	
Electrical Contact	SJ1F-01GF-P0.8	
Applicable Wire Size	AWG20 to 24	
Outer Diameter of Insulating Sheath	1.11 dia. to 1.53 dia. mm	
Crimp Tool	Hand tool: YRS-8841 Applicator: APLMK SJ1F/M-01-08	
Mounting Screw	M2 Pan-head screw	
Applicable Cable Outer Diameter	7±0.3 dia. mm	

Selecting Cables

(4) Servomotor-end Connector Kit Specifications: For 200 to 550 W Servomotors

Items	Specifications	External Dimensions mm	
Order No.	JZSP-CSM9-2-E (Cables are not included.)		
Applicable Servomotors	SGMAV-02A, -04A, -06A		
Manufacturer	J.S.T. Mfg. Co., Ltd.		
Receptacle	J27-06FMH-7KL-1-CF		
Electrical Contact	SJ2F-01GF-P1.0		
Applicable Wire Size	AWG20 to 24		
Outer Diameter of Insulating Sheath	1.11 dia. to 1.53 dia. mm		
Crimp Tool	Hand tool		YRS-8861
	Applicator		APLMK SJ2F/M-01-08
Mounting Screw	M2 Pan-head screw		
Applicable Cable Outer Diameter	7±0.3 dia. mm		

(5) Servomotor-end Connector Kit Specifications: For 750 W, 1.0 kW Servomotors

Items	Specifications	External Dimensions mm		
Order No.	JZSP-CSM9-3-E (Cables are not included.)			
Applicable Servomotors	SGMAV-08A, -10A			
Manufacturer	J.S.T. Mfg. Co., Ltd.			
Receptacle	J37-06FMH-8KL-1-CF			
Cable Type	Standard			
Electrical Contact	SJ3F-41GF-P1.8 (For power terminals)		SJ3F-01GF-P1.8 (For holding brake terminals)	
	Applicable Wire Size		AWG16 to 20	AWG20 to 24
Outer Diameter of Insulating Sheath	1.53 dia. to 2.5 dia. mm		1.11 dia. to 1.86 dia. mm	
Crimp Tool	Hand tool		YRF-880	YRF-881
	Applicator		APLMK SF3F/M-41-20	APLMK SF3F/M-01-20
Mounting Screw	M2.5 Pan-head screw			
Applicable Cable Outer Diameter	8±0.3 dia. mm			

Selecting Cables

(6) Cable Specifications: For 50 to 550 W Servomotors

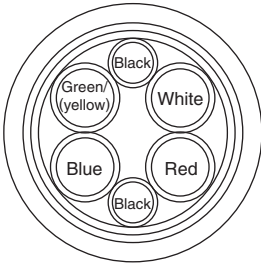
Items	Standard Type	Flexible Type
Order No.*	JZSP-CSM90-□□-E (50 m max.)	JZSP-CSM80-□□-E (50 m max.)
Specifications	UL2517 (Rating temperature: 105°C) AWG20×6C For power line: AWG20 (0.52 mm ²) Outer diameter of insulating sheath: 1.53 dia. mm For holding brake line: AWG20 (0.52 mm ²) Outer diameter of insulating sheath: 1.53 dia. mm	UL2517 (Rating temperature: 105°C) AWG22×6C For power line: AWG22 (0.33 mm ²) Outer diameter of insulating sheath: 1.37 dia. mm For holding brake line: AWG22 (0.33 mm ²) Outer diameter of insulating sheath: 1.37 dia. mm
Finished Dimensions	7±0.3 dia. mm	
Internal Configuration and Lead Color		
Yaskawa Standard Specifications (Standard Length)	Cable length: 5 m, 10 m, 15 m, 20 m, 30 m, 40 m, 50 m	

*: Specify the cable length in □□ of order no.
 Example: JZSP-CSM90-05-E (5 m)

(7) Cable Specifications: For 750 W, 1.0 kW Servomotors

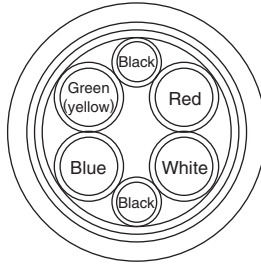
Items	Standard Type	Flexible Type
Order No.*	JZSP-CSM91-□□-E (50 m max.)	JZSP-CSM81-□□-E (50 m max.)
Specifications	UL2517 (Rating temperature: 105°C) AWG16×4C, AWG20×2C For power line: AWG16 (1.31 mm ²) Outer diameter of insulating sheath: 2.15 dia. mm For holding brake line: AWG20 (0.52 mm ²) Outer diameter of insulating sheath: 1.6 dia. mm	UL2517 (Rating temperature: 105°C) AWG16×4C, AWG22×2C For power line: AWG16 (1.31 mm ²) Outer diameter of insulating sheath: 2.35 dia. mm For holding brake line: AWG22 (0.33 mm ²) Outer diameter of insulating sheath: 1.37 dia. mm
Finished Dimensions	8±0.3 dia. mm	
Internal Configuration and Lead Color		
Yaskawa Standard Specifications (Standard Length)	Cable length: 5 m, 10 m, 15 m, 20 m, 30 m, 40 m, 50 m	

*: Specify the cable length in □□ of order no.
 Example: JZSP-CSM91-15-E (15 m)

Selecting Cables

● Encoder Cables (Length: 20 m or less)

Name	Length	Order No.		Specifications	Details
		Standard Type	Flexible Type*		
Cable with Connectors (For Incremental Encoder)	3 m	JZSP-CSP01-03-E	JZSP-CSP21-03-E		(1)
	5 m	JZSP-CSP01-05-E	JZSP-CSP21-05-E		
	10 m	JZSP-CSP01-10-E	JZSP-CSP21-10-E		
	15 m	JZSP-CSP01-15-E	JZSP-CSP21-15-E		
	20 m	JZSP-CSP01-20-E	JZSP-CSP21-20-E		
Cable with Connectors (For Absolute Encoder, with a Battery Case)	3 m	JZSP-CSP05-03-E	JZSP-CSP25-03-E		(2)
	5 m	JZSP-CSP05-05-E	JZSP-CSP25-05-E		
	10 m	JZSP-CSP05-10-E	JZSP-CSP25-10-E		
	15 m	JZSP-CSP05-15-E	JZSP-CSP25-15-E		
	20 m	JZSP-CSP05-20-E	JZSP-CSP25-20-E		
SERVOPACK-end Connector Kit		JZSP-CMP9-1-E		Soldered 	(3)
Encoder-end Connector Kit		JZSP-CSP9-2-E		Crimping Type (A crimp tool is required.) 	
Cables	3 m	JZSP-CMP09-03-E	JZSP-CSP39-03-E		(4)
	5 m	JZSP-CMP09-05-E	JZSP-CSP39-05-E		
	10 m	JZSP-CMP09-10-E	JZSP-CSP39-10-E		
	15 m	JZSP-CMP09-15-E	JZSP-CSP39-15-E		
	20 m	JZSP-CMP09-20-E	JZSP-CSP39-20-E		

*: Use flexible cables for movable sections such as robot arms.

Note: When the battery from the host controller is used for the absolute encoder, no battery case is required. In this case, use a cable for the incremental encoders.

(1) Wiring Specifications for Cable with Connectors (For incremental encoder)

• Standard Type

SERVOPACK End		Encoder (Servomotor) End	
Pin No.	Signal	Pin No.	Wire Color
6	/PS	5	Light blue/white
5	PS	4	Light blue
4	BAT (-)	8	Orange/white
3	BAT (+)	9	Orange
2	PG 0V	3	Black
1	PG 5V	6	Red
Shell	FG	Shell	FG

• Flexible Type

SERVOPACK End		Encoder (Servomotor) End	
Pin No.	Signal	Pin No.	Wire Color
6	/PS	5	Black/pink
5	PS	4	Red/pink
4	BAT (-)	8	Black/light blue
3	BAT (+)	9	Red/light blue
2	PG 0V	3	Green
1	PG 5V	6	Orange
Shell	FG	Shell	FG

(2) Wiring Specifications for Cable with Connectors (For absolute encoder, with a battery case)

• Standard Type

SERVOPACK End		Encoder (Servomotor) End	
Pin No.	Signal	Pin No.	Wire Color
6	/PS	5	Light blue/white
5	PS	4	Light blue
4	BAT (-)	8	Orange/white
3	BAT (+)	9	Orange
2	PG 0V	3	Black
1	PG 5V	6	Red
Shell	FG	Shell	FG

Battery Case	
Pin No.	Signal
2	BAT (-)
1	BAT (+)

• Flexible Type

SERVOPACK End		Encoder (Servomotor) End	
Pin No.	Signal	Pin No.	Wire Color
6	/PS	5	Black/pink
5	PS	4	Red/pink
4	BAT (-)	8	Black/light blue
3	BAT (+)	9	Red/light blue
2	PG 0V	3	Green
1	PG 5V	6	Orange
Shell	FG	Shell	FG

Battery Case	
Pin No.	Signal
2	BAT (-)
1	BAT (+)

Selecting Cables

(3) SERVOPACK-end/Encoder-end Connector Kit Specifications

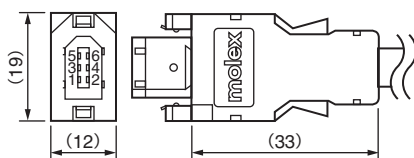
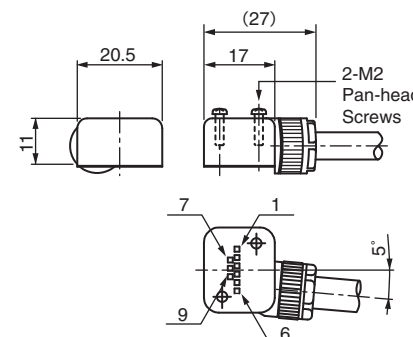
Items	SERVOPACK-end Connector Kit	Encoder-end Connector Kit
Order No.	JZSP-CMP9-1-E (Cables are not included.)	JZSP-CSP9-2-E (Cables are not included.)
Manufacturer	Molex Japan Co., Ltd.	Molex Japan Co., Ltd.
Specifications	55100-0670 (soldered) Product Specification: PS-54280	54346-0070 (crimped)* Mounting screw: M2 pan-head screw (×2) Outer diameter of applicable cable: 6.3 dia. to 7.7 dia. mm Applicable wire size: AWG22 to 26 Outer diameter of insulating sheath: 1.05 dia. to 1.4 dia. mm Application Specification: AS-54992 Crimping Specification: CS-56161
External Dimensions mm		

*: A crimp tool is required.

The following crimp tools are applicable for the cables provided by Yaskawa. When using other wire sizes, contact the respective manufacturer for crimp tools.
Applicable crimp tool for Yaskawa's wire size: Hand Tool Model No. 57175-5000
Applicator Model No. 57175-3000

(4) Cable Specifications

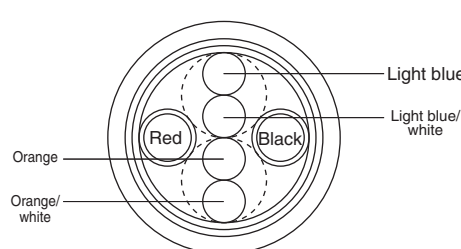
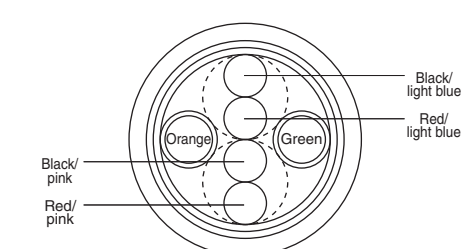
Items	Standard Type	Flexible Type
Order No.*	JZSP-CMP09-□□-E	JZSP-CSP39-□□-E
Cable Length	20 m max.	
Specifications	UL20276 (Rating temperature: 80°C) AWG22×2C+AWG24×2P AWG22 (0.33 mm ²) Outer diameter of insulating sheath: 1.15 dia. mm AWG24 (0.20 mm ²) Outer diameter of insulating sheath: 1.09 dia. mm	UL20276 (Rating temperature: 80°C) AWG22×2C+AWG24×2P AWG22 (0.33 mm ²) Outer diameter of insulating sheath: 1.35 dia. mm AWG24 (0.20 mm ²) Outer diameter of insulating sheath: 1.21 dia. mm
Finished Dimensions	6.5 dia. mm	6.8 dia. mm
Internal Configuration and Lead Color		
Yaskawa Standards Specifications (Standard Length)	Cable length: 5 m, 10 m, 15 m, 20 m	

*: Specify the cable length in □□ of order no.
Example: JZSP-CMP09-05-E (5 m)

Selecting Cables

● Relay Encoder Cables (For extending from 30 to 50 m)

Name	Length	Order No. Standard Type	Specifications	Details
① Encoder-end Cables (For incremental and absolute encoder)	0.3 m	JZSP-CSP11-E	<p>SERVOPACK End 0.3 m Encoder End</p> <p>Plug Connector (Crimped) Connector (Molex Japan Co., Ltd.) (Molex Japan Co., Ltd.)</p>	(1)
② Cable with Connectors (For incremental and absolute encoder)	30 m	JZSP-UCMP00-30-E	<p>SERVOPACK End L Encoder End</p> <p>Plug Connector (Crimped) Socket Connector (Soldered) (Molex Japan Co., Ltd.) (Molex Japan Co., Ltd.)</p>	(2)
	40 m	JZSP-UCMP00-40-E		
	50 m	JZSP-UCMP00-50-E		
③ Cable with a Battery Case (Required when an absolute encoder is used.)	0.3 m	JZSP-CSP12-E*	<p>SERVOPACK End 0.3 m Encoder End</p> <p>Plug Connector (Crimped) Socket Connector (Soldered) (Molex Japan Co., Ltd.) (Molex Japan Co., Ltd.)</p> <p>Battery Case (Battery attached)</p>	(3)
④ Cables	30 m	JZSP-CMP19-30-E		(4)
	40 m	JZSP-CMP19-40-E		
	50 m	JZSP-CMP19-50-E		

* : When using an incremental encoder or using an absolute encoder with a battery connected to the host controller, no battery case is required.

(1) Wiring Specifications for Encoder-end Cable

SERVOPACK End		Encoder (Servomotor) End	
Pin No.	Signal	Pin No.	Wire Color
6	/PS	5	Light blue/white
5	PS	4	Light blue
4	BAT (-)	8	Orange/white
3	BAT (+)	9	Orange
2	PG 0V	3	Black
1	PG 5V	6	Red
Shell	FG	Shell	FG

Shield Wire

(2) Wiring Specifications for Cable with Connectors

SERVOPACK End		Encoder (Servomotor) End	
Pin No.	Signal	Pin No.	Wire Color
6	/PS	6	Light blue/white
5	PS	5	Light blue
4	BAT (-)	4	Orange/white
3	BAT (+)	3	Orange
2	PG 0V	2	Black
1	PG 5V	1	Red
Shell	FG	Shell	FG

Shield Wire

Selecting Cables

(3) Wiring Specifications for Cable with a Battery Case

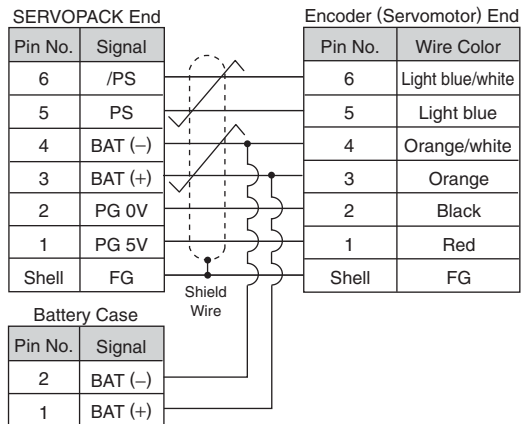

(4) Cable Specifications

Item	Standard Type
Order No.*	JZSP-CMP19-□□-E
Cable Length	50 m max.
Specifications	UL20276 (Rating temperature: 80°C) AWG16×2C+AWG26×2P AWG16 (1.31 mm ²) Outer diameter of insulating sheath: 2.0 dia. mm AWG26 (0.13 mm ²) Outer diameter of insulating sheath: 0.91 dia. mm
Finished Dimensions	6.8 dia. mm
Internal Configuration and Lead Colors	
Yaskawa Standard Specifications (Standard Length)	Cable length: 30 m, 40 m, 50 m

*: Specify the cable length in □□ of order no.
Example: JZSP-CMP19-30-E (30 m)

With Low-backlash Gears

Ratings and Specifications

Time Rating: Continuous
 Insulation Resistance: 500 VDC, 10 MΩ min.
 Ambient Temperature: 0 to 40°C
 Excitation: Permanent magnet
 Mounting: Flange-mounted
 Gear Mechanism: Planetary gear mechanism
 Thermal Class: B

Withstand Voltage: 1500 VAC for one minute
 Enclosure: Totally enclosed, self-cooled, IP55
 (except for shaft opening)
 Ambient Humidity: 20% to 80% (no condensation)
 Drive Method: Direct drive
 Rotation Direction: Counterclockwise (CCW) with forward run
 reference when viewed from the load side

Servomotor Model SGMAV-	Servomotor					Gear					
	Rated Output W	Rated Speed min ⁻¹	Max. Speed min ⁻¹	Rated Torque N·m	Instantaneous Peak Torque N·m	Gear Ratio	Lost Motion arc-min	Rated Torque / Efficiency*1 N·m / %	Instantaneous Peak Torque N·m	Rated Speed min ⁻¹	Max. Speed min ⁻¹
A5A□AH1□	50	3000	6000	0.159	0.477	1/5	3 max.	0.433/64*2	1.98	600	1200
A5A□AH2□						1/9		1.12/78	3.8	333	667
A5A□AHC□						1/21		2.84/85	9.0	143	286
A5A□AH7□						1/33		3.68/70	13.4	91	182
01A□AH1□	100	3000	6000	0.318	0.955	1/5	3 max.	1.06/78*2	4.20	600	1200
01A□AHB□						1/11		2.52/72	9.0	273	545
01A□AHC□						1/21		5.35/80	17.8	143	286
01A□AH7□						1/33		7.35/70	27.4	91	182
C2A□AH1□	150	3000	6000	0.477	1.43	1/5	3 max.	1.68/83*2	6.45	600	1200
C2A□AHB□						1/11		3.53/79*2	13.9	273	545
C2A□AHC□						1/21		6.3/70*2	26.2	143	286
C2A□AH7□						1/33		11.2/79*2	42.5	91	182
02A□AH1□	200	3000	6000	0.637	1.91	1/5	3 max.	2.39/75	8.31	600	1200
02A□AHB□						1/11		5.74/82	18.7	273	545
02A□AHC□						1/21		10.2/76	35.7	143	286
02A□AH7□						1/33		17.0/81	57.4	91	182
04A□AH1□	400	3000	6000	1.27	3.82	1/5	3 max.	5.35/84	17.2	600	1200
04A□AHB□						1/11		11.5/82	38.2	273	545
04A□AHC□						1/21		23.0/86	74.6	143	286
04A□AH7□						1/33		34.0/81	115	91	182
06A□AH1□	550	3000	6000	1.75	5.25	1/5	3 max.	6.9/79	23.6	600	1200
06A□AHB□						1/11		16.6/86	53.7	273	545
06A□AHC□						1/21		29.4/80	100	143	286
06A□AH7□						1/33		49.1/85	159	91	182
08A□AH1□	750	3000	6000	2.39	7.16	1/5	3 max.	10.0/84	32.9	600	1200
08A□AHB□						1/11		23.1/88	73.3	273	545
08A□AHC□						1/21		42.1/84	138	143	286
08A□AH7□						1/33		69.3/88	220	91	182
10A□AH1□	1000	3000	6000	3.18	9.55	1/5	3 max.	13.7/86	44.4	600	1200
10A□AHB□						1/11		29.1/83	96.6	273	545
10A□AHC□						1/21		58.2/87	186	143	286
10A□AH7□						1/33		94.5/90	296	91	182

*1: Gear output torque is expressed using the following equation.

$$(\text{Gear output torque}) = (\text{Servomotor output torque}) \times \frac{1}{(\text{gear ratio})} \times (\text{efficiency})$$

Gear efficiency depends on operating conditions such as output torque, motor speed, and temperature etc. The values in the table are representative values with rated torque, rated speed, and an ambient temperature of 25°C, and are not guaranteed values.

*2: When using SGMAV-A5A, -01A, -C2A servomotors with a gear ratio of 1/5, or an SGMAV-C2A servomotor with a gear ratio of 1/11, maintain an 85% max. effective load ratio. For an SGMAV-C2A servomotor with a gear ratio of 1/21 or 1/31, maintain a 90% max. effective load ratio.

Notes: 1 The gear mounted to our servomotor has not been broken in. Break in the servomotor if necessary. First, run the motor at low speed with no load. If no problems arise, gradually increase the speed and load.

2 The no-load torque for a servomotor with a gear is high immediately after the servomotor starts, and it then decreases and becomes stable a few minutes later. This is a common phenomenon caused by grease being circulated in the gear and not by a faulty gear.

IMPORTANT The SERVOPACK speed control range is 5000:1. When using servomotors at extremely low speeds (0.02 min⁻¹ at gear output shaft), or when using servomotors with 1 pulse feed reference for extended periods etc., the gear bearing lubrication may be insufficient. That may cause deterioration of bearing or increase the load ratio. Contact your Yaskawa representative if you are using your servomotor under these conditions.

With Low-backlash Gears Ratings and Specifications

● **Moment of Inertia and Allowable Radial and Thrust Loads**

Servomotor Model SGMAV-	Moment of Inertia × 10 ⁻⁴ kg·m ²				Servomotors with Low-backlash Gears			Reference Diagram
	Motor + Gear	Gear	Flange Output		Allowable Radial Load (Fr) N	Allowable Thrust Load (Fs) N	LR mm	
			Motor + Gear	Gear				
A5A□AH1□	0.0302	0.006	0.0292	0.005	95	431	37	
A5A□AH2□	0.0272	0.003	0.0272	0.003	113	514	37	
A5A□AHC□	0.0282	0.004	0.0282	0.004	146	663	37	
A5A□AH7□	0.0692	0.045	0.0692	0.045	267	1246	53	
01A□AH1□	0.0430	0.005	0.0420	0.004	95	431	37	
01A□AHB□	0.0980	0.060	0.0970	0.059	192	895	53	
01A□AHC□	0.0880	0.050	0.0880	0.050	233	1087	53	
01A□AH7□	0.1030	0.065	0.1020	0.064	605	2581	75	
C2A□AH1□	0.0581	0.005	0.0571	0.004	95	431	37	
C2A□AHB□	0.1131	0.060	0.1121	0.059	192	895	53	
C2A□AHC□	0.1631	0.110	0.1611	0.108	528	2254	75	
C2A□AH7□	0.1181	0.065	0.1171	0.064	605	2581	75	
02A□AH1□	0.323	0.207	0.317	0.201	152	707	53	
02A□AHB□	0.309	0.193	0.308	0.192	192	895	53	
02A□AHC□	0.606	0.490	0.604	0.480	528	2254	75	
02A□AH7□	0.566	0.450	0.565	0.449	605	2581	75	
04A□AH1□	0.397	0.207	0.391	0.201	152	707	53	
04A□AHB□	0.760	0.570	0.750	0.560	435	1856	75	
04A□AHC□	0.680	0.490	0.678	0.488	528	2254	75	
04A□AH7□	0.810	0.620	0.800	0.610	951	4992	128	
06A□AH1□	1.026	0.700	0.986	0.660	343	1465	75	
06A□AHB□	0.896	0.570	0.886	0.560	435	1856	75	
06A□AHC□	1.166	0.840	1.146	0.820	830	4359	128	
06A□AH7□	0.946	0.620	0.936	0.610	951	4992	128	
08A□AH1□	1.469	0.700	1.429	0.660	343	1465	75	
08A□AHB□	1.369	0.600	1.359	0.590	435	1856	75	
08A□AHC□	3.77	3.000	3.75	2.980	830	4359	128	
08A□AH7□	3.57	2.800	3.56	2.790	951	4992	128	
10A□AH1□	1.90	0.700	1.86	0.660	343	1465	75	
10A□AHB□	4.60	3.400	4.54	3.340	684	3590	128	
10A□AHC□	4.20	3.000	4.18	2.980	830	4359	128	
10A□AH7□	4.00	2.800	3.99	2.790	951	4992	128	

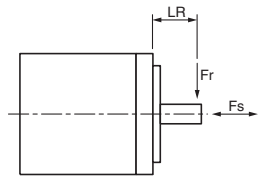

IMPORTANT

The gear generates the loss at gear mechanism and oil seal. The loss varies with torque and motor speed conditions. The temperature rise depends on heating conditions. Always check the actual gear and motor temperature. If the temperature is high, take the measures shown below.

- Decrease the load ratio.
- Change the heating conditions.
- Cool the motor with a cooling fan etc.

Rated Output W	Heat Sink Size			
	1/5	1/9 or 1/11	1/21	1/33
50	A			
100	A			
150	A			
200	B			
400	B			
550	B			
750	C			
1000	C			

A: 250 mm×250 mm×6 mm, aluminum
 B: 300 mm×300 mm×12 mm, aluminum
 C: 350 mm×350 mm×12 mm, aluminum

(1) 50 to 150 W

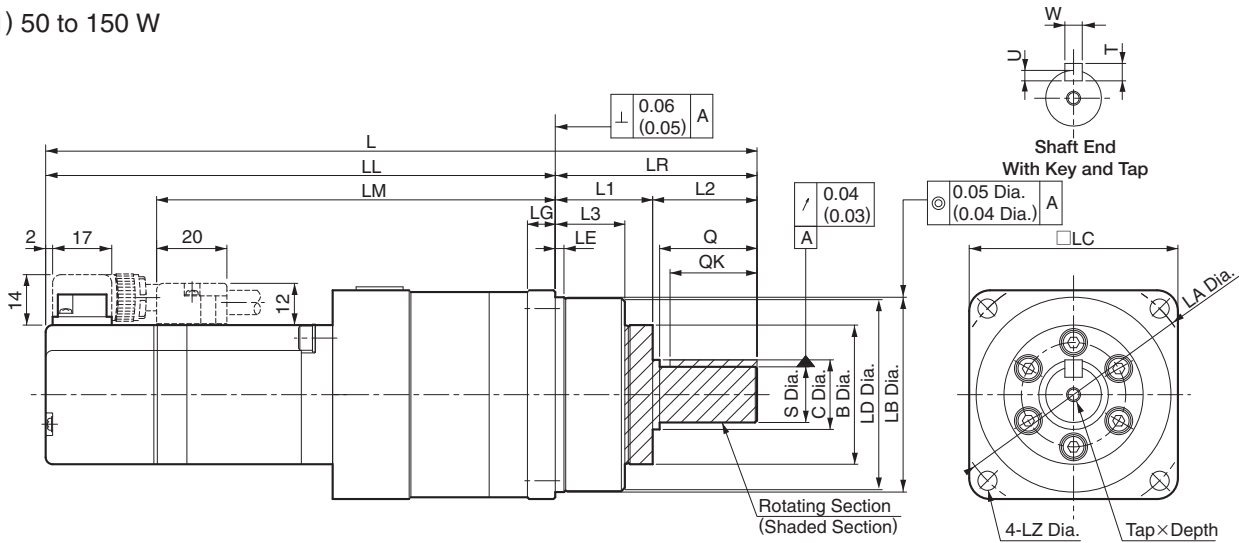

Model SGMAV-	Gear Ratio	L	LL	LM	Flange Face Dimensions								
					LR	LE	LG	B	LD	LB	LC	LA	LZ
A5A□AH1※1 (A5A□AH1※C)	1/5	152 (197)	110 (155)	78	42	2.2	5	29	39.5	40 ⁰ _{-0.025}	40	46	3.4
A5A□AH2※1 (A5A□AH2※C)	1/9												
A5A□AHC※1 (A5A□AHC※C)	1/21	161 (206)	119 (164)	87									
A5A□AH7※1 (A5A□AH7※C)	1/33	192.5 (237.5)	134.5 (179.5)	102.5	58	2.5	8	40	55.5	56 ⁰ _{-0.030}	60	70	5.5
01A□AH1※1 (01A□AH1※C)	1/5	164 (209)	122 (167)	90	42	2.2	5	29	39.5	40 ⁰ _{-0.025}	40	46	3.4
01A□AHB※1 (01A□AHB※C)	1/11	204.5 (249.5)	146.5 (191.5)	114.5	58	2.5	8	40	55.5	56 ⁰ _{-0.030}	60	70	5.5
01A□AHC※1 (01A□AHC※C)	1/21												
01A□AH7※1 (01A□AH7※C)	1/33	229 (274)	149 (194)	117	80	7.5	10	59	84	85 ⁰ _{-0.035}	90	105	9
C2A□AH1※1 (C2A□AH1※C)	1/5	176 (221)	134 (179)	102	42	2.2	5	29	39.5	40 ⁰ _{-0.025}	40	46	3.4
C2A□AHB※1 (C2A□AHB※C)	1/11	216.5 (261.5)	158.5 (203.5)	126.5	58	2.5	8	40	55.5	56 ⁰ _{-0.030}	60	70	5.5
C2A□AHC※1 (C2A□AHC※C)	1/21	241 (286)	161 (206)	129	80	7.5	10	59	84	85 ⁰ _{-0.035}	90	105	9
C2A□AH7※1 (C2A□AH7※C)	1/33												

Model SGMAV-	Flange Face Dimensions						Tap × Depth	Key Dimensions				Approx. Mass kg
	L1	L2	L3	Q	C	S		QK	U	W	T	
A5A□AH1※1 (A5A□AH1※C)	22	20	14.6	-	-	10 ⁰ _{-0.015}	M3×6L	15	2.5	4	4	0.6 (0.9)
A5A□AH2※1 (A5A□AH2※C)												
A5A□AHC※1 (A5A□AHC※C)												
A5A□AH7※1 (A5A□AH7※C)	28	30	20	28	20	16 ⁰ _{-0.018}	M4×8L	25	3	5	5	1.3 (1.6)
01A□AH1※1 (01A□AH1※C)	22	20	14.6	-	-	10 ⁰ _{-0.015}	M3×6L	15	2.5	4	4	0.7 (1.0)
01A□AHB※1 (01A□AHB※C)	28	30	20	28	20	16 ⁰ _{-0.018}	M4×8L	25	3	5	5	1.4 (1.7)
01A□AHC※1 (01A□AHC※C)												
01A□AH7※1 (01A□AH7※C)												
C2A□AH1※1 (C2A□AH1※C)	22	20	14.6	-	-	10 ⁰ _{-0.015}	M3×6L	15	2.5	4	4	0.8 (1.1)
C2A□AHB※1 (C2A□AHB※C)	28	30	20	28	20	16 ⁰ _{-0.018}	M4×8L	25	3	5	5	1.5 (1.8)
C2A□AHC※1 (C2A□AHC※C)												
C2A□AH7※1 (C2A□AH7※C)												

※: The asterisk (*) describes the values of the 8th digit of the model designation, "shaft end code 6 (straight with key and tap)." If a key or tap is not necessary, order a servomotor with "shaft end code 2 (without key and tap)."

Notes: 1 The models and values in parentheses are for servomotors with holding brakes.

2 Please note that gear dimensions are different from those of Σ-I, Σ-II, and Σ-III series.

With Low-backlash Gears External Dimensions Units: mm

● Flange Output Face

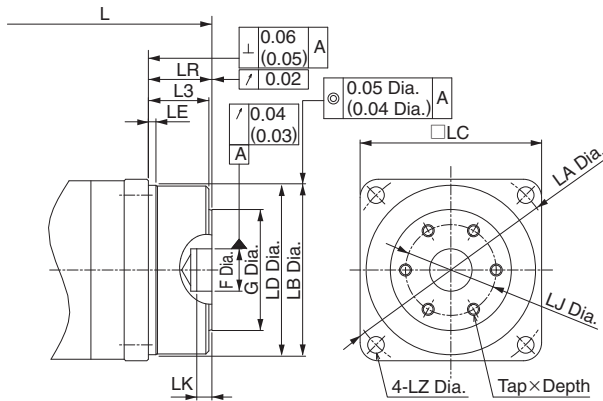

Model SGMAV-	Gear Ratio	L	LR	LJ	F	G	LK	No. of pcs Tap x Depth	Approx. Mass kg
A5A□AH101 (A5A□AH10C)	1/5	125 (170)	15	18	5 ^{+0.012} ₀	24	3	3-M4×6L	0.6 (0.9)
A5A□AH201 (A5A□AH20C)	1/9								
A5A□AHC01 (A5A□AHC0C)	1/21	134 (179)							
A5A□AH701 (A5A□AH70C)	1/33	155.5 (200.5)	21	30	14 ^{+0.018} ₀	40	5	6-M4×7L	1.2 (1.5)
01A□AH101 (01A□AH10C)	1/5	137 (182)	15	18	5 ^{+0.012} ₀	24	3	3-M4×6L	0.7 (1.0)
01A□AHB01 (01A□AHB0C)	1/11	167.5 (212.5)	21	30	14 ^{+0.018} ₀	40	5	6-M4×7L	1.3 (1.6)
01A□AHC01 (01A□AHC0C)	1/21								
01A□AH701 (01A□AH70C)	1/33	176 (221)	27	45	24 ^{+0.021} ₀	59	5	6-M6×10L	2.4 (2.7)
C2A□AH101 (C2A□AH10C)	1/5	149 (194)	15	18	5 ^{+0.012} ₀	24	3	3-M4×6L	0.8 (1.1)
C2A□AHB01 (C2A□AHB0C)	1/11	179.5 (224.5)	21	30	14 ^{+0.018} ₀	40	5	6-M4×7L	1.4 (1.7)
C2A□AHC01 (C2A□AHC0C)	1/21	188 (233)	27	45	24 ^{+0.021} ₀	59	5	6-M6×10L	2.5 (2.8)
C2A□AH701 (C2A□AH70C)	1/33								

Notes: 1 The models and values in parentheses are for servomotors with holding brakes.
2 The dimensions not given on the table above are the same as those in the table on the previous page.

IMPORTANT

Regarding the flange output type shaft end, when the flange "LC" is 40 mm, we recommend designing a servomotor with the dimensions shown in the diagram on the right, in order to secure the gap between the gear oil seal and the parts on the load side.

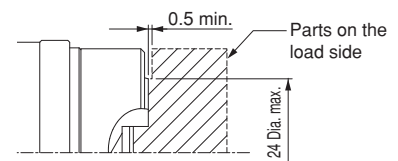

(2) 200 to 550 W

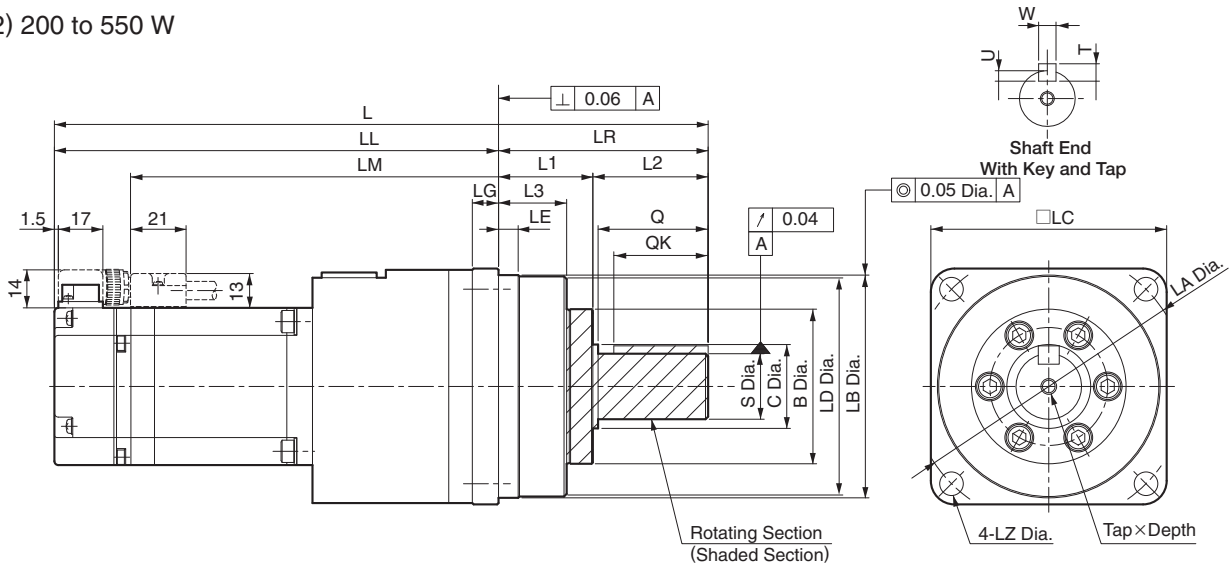

Model SGMAV-	Gear Ratio	L	LL	LM	Flange Face Dimensions									
					LR	LE	LG	B	LD	LB	LC	LA	LZ	
02A□AH1※1 (02A□AH1※C)	1/5	202 (242)	144 (184)	115	58	2.5	8	40	55.5	56 ⁰ _{-0.030}	60	70	5.5	
02A□AHB※1 (02A□AHB※C)	1/11													
02A□AHC※1 (02A□AHC※C)	1/21	231 (271)	151 (191)	122	80	7.5	10	59	84	85 ⁰ _{-0.035}	90	105	9	
02A□AH7※1 (02A□AH7※C)	1/33													
04A□AH1※1 (04A□AH1※C)	1/5	220.5 (260.5)	162.5 (202.5)	133.5	58	2.5	8	40	55.5	56 ⁰ _{-0.030}	60	70	5.5	
04A□AHB※1 (04A□AHB※C)	1/11													
04A□AHC※1 (04A□AHC※C)	1/21	249.5 (289.5)	169.5 (209.5)	140.5	80	7.5	10	59	84	85 ⁰ _{-0.035}	90	105	9	
04A□AH7※1 (04A□AH7※C)	1/33													
06A□AH1※1 (06A□AH1※C)	1/5	275.5 (321.5)	195.5 (241.5)	166.5	80	7.5	10	59	84	85 ⁰ _{-0.035}	90	105	9	
06A□AHB※1 (06A□AHB※C)	1/11													
06A□AHC※1 (06A□AHC※C)	1/21	361.5 (407.5)	228.5 (274.5)	199.5	133	12.5	13	84	114	115 ⁰ _{-0.035}	120	135	11	
06A□AH7※1 (06A□AH7※C)	1/33													

Model SGMAV-	Flange Face Dimensions						Tap × Depth	Key Dimensions				Approx. Mass kg
	L1	L2	L3	Q	C	S		QK	U	W	T	
02A□AH1※1 (02A□AH1※C)	28	30	20	28	20	16 ⁰ _{-0.018}	M4×8L	25	3	5	5	1.9 (2.5)
02A□AHB※1 (02A□AHB※C)												2.0 (2.6)
02A□AHC※1 (02A□AHC※C)	36	44	26	42	32	25 ⁰ _{-0.021}	M6×12L	36	4	8	7	3.8 (4.4)
02A□AH7※1 (02A□AH7※C)												
04A□AH1※1 (04A□AH1※C)	28	30	20	28	20	16 ⁰ _{-0.018}	M4×8L	25	3	5	5	2.2 (2.8)
04A□AHB※1 (04A□AHB※C)												
04A□AHC※1 (04A□AHC※C)	36	44	26	42	32	25 ⁰ _{-0.021}	M6×12L	36	4	8	7	4.1 (4.7)
04A□AH7※1 (04A□AH7※C)												
06A□AH1※1 (06A□AH1※C)	48	85	33	82	44	40 ⁰ _{-0.025}	M10×20L	70	5	12	8	8.7 (9.3)
06A□AHB※1 (06A□AHB※C)												
06A□AHC※1 (06A□AHC※C)	36	44	26	42	32	25 ⁰ _{-0.021}	M6×12L	36	4	8	7	4.4 (5.1)
06A□AH7※1 (06A□AH7※C)												4.6 (5.3)
06A□AHC※1 (06A□AHC※C)	48	85	33	82	44	40 ⁰ _{-0.025}	M10×20L	70	5	12	8	9.2 (9.9)
06A□AH7※1 (06A□AH7※C)												

※: The asterisk (※) describes the values of the 8th digit of the model designation, "shaft end code 6 (straight with key and tap)." If a key or tap is not necessary, order a servomotor with "shaft end code 2 (without key and tap)."

Notes: 1 The models and values in parentheses are for servomotors with holding brakes.
2 Please note that gear dimensions are different from those of Σ-I, Σ-II, and Σ-III series.

With Low-backlash Gears External Dimensions Units: mm

● Flange Output Face

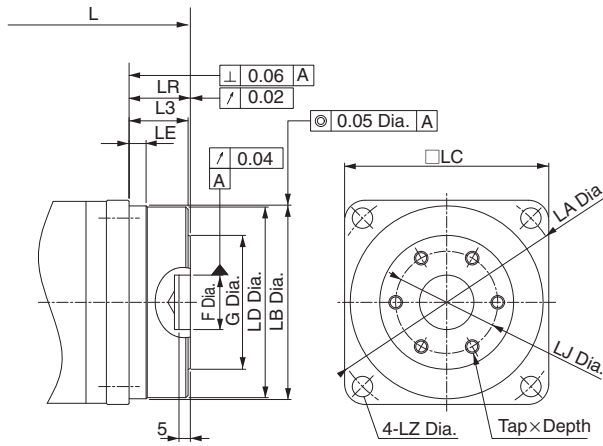

Model SGMAV-	Gear Ratio	L	LR	LJ	F	G	No. of pcs Tap x Depth	Approx. Mass kg
02A□AH101 (02A□AH10C)	1/5	165 (205)	21	30	14 ^{+0.018} ₀	40	6-M4×7L	1.8 (2.4)
02A□AHB01 (02A□AHB0C)	1/11							1.9 (2.5)
02A□AHC01 (02A□AHC0C)	1/21	178 (218)	27	45	24 ^{+0.021} ₀	59	6-M6×10L	3.4 (4.0)
02A□AH701 (02A□AH70C)	1/33							
04A□AH101 (04A□AH10C)	1/5	183.5 (223.5)	21	30	14 ^{+0.018} ₀	40	6-M4×7L	2.1 (2.7)
04A□AHB01 (04A□AHB0C)	1/11	196.5 (236.5)	27	45	24 ^{+0.021} ₀	59	6-M6×10L	3.7 (4.3)
04A□AHC01 (04A□AHC0C)	1/21							
04A□AH701 (04A□AH70C)	1/33	237.5 (277.5)	35	60	32 ^{+0.025} ₀	84	6-M8×12L	7.3 (7.9)
06A□AH101 (06A□AH10C)	1/5	222.5 (268.5)	27	45	24 ^{+0.021} ₀	59	6-M6×10L	4.0 (4.7)
06A□AHB01 (06A□AHB0C)	1/11							4.2 (4.9)
06A□AHC01 (06A□AHC0C)	1/21	263.5 (309.5)	35	60	32 ^{+0.025} ₀	84	6-M8×12L	7.8 (8.5)
06A□AH701 (06A□AH70C)	1/33							

Notes: 1 The models and values in parentheses are for servomotors with holding brakes.
2 The dimensions not given on the table above are the same as those in the table on the previous page.

With Low-backlash Gears

External Dimensions Units: mm

(3) 750 W, 1.0 kW

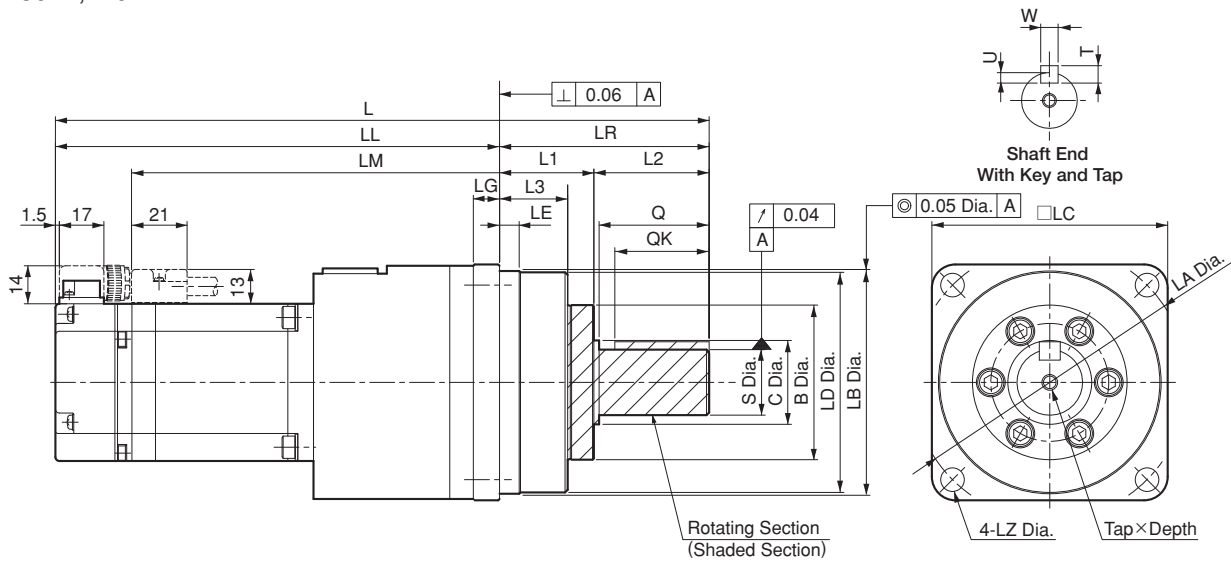

Model SGMAV-	Gear Ratio	L	LL	LM	Flange Face Dimensions								
					LR	LE	LG	B	LD	LB	LC	LA	LZ
08A□AH1※1 (08A□AH1※C)	1/5	273 (318)	193 (238)	163	80	7.5	10	59	84	85	90	105	9
08A□AHB※1 (08A□AHB※C)	1/11												
08A□AHC※1 (08A□AHC※C)	1/21	352 (397)	219 (264)	189	133	12.5	13	84	114	115	120	135	11
08A□AH7※1 (08A□AH7※C)	1/33												
10A□AH1※1 (10A□AH1※C)	1/5	303 (353)	223 (273)	193	80	7.5	10	59	84	85	90	105	9
10A□AHB※1 (10A□AHB※C)	1/11												
10A□AHC※1 (10A□AHC※C)	1/21	382 (432)	249 (299)	219	133	12.5	13	84	114	115	120	135	11
10A□AH7※1 (10A□AH7※C)	1/33												

Model SGMAV-	Flange Face Dimensions			Q	C	S	Tap × Depth	Key Dimensions				Approx. Mass kg
	L1	L2	L3					QK	U	W	T	
08A□AH1※1 (08A□AH1※C)	36	44	26	42	32	25	M6×12L	36	4	8	7	5.2 (6.1)
08A□AHB※1 (08A□AHB※C)												5.4 (6.3)
08A□AHC※1 (08A□AHC※C)	48	85	33	82	44	40	M10×20L	70	5	12	8	10.1 (11)
08A□AH7※1 (08A□AH7※C)												
10A□AH1※1 (10A□AH1※C)	36	44	26	42	32	25	M6×12L	36	4	8	7	6.5 (7.5)
10A□AHB※1 (10A□AHB※C)												
10A□AHC※1 (10A□AHC※C)	48	85	33	82	44	40	M10×20L	70	5	12	8	11.4 (12.4)
10A□AH7※1 (10A□AH7※C)												

: The asterisk () describes the values of the 8th digit of the model designation, "shaft end code 6 (straight with key and tap)." If a key or tap is not necessary, order a servomotor with "shaft end code 2 (without key and tap)."

Notes: 1 The models and values in parentheses are for servomotors with holding brakes.
2 Please note that gear dimensions are different from those of Σ-I, Σ-II, and Σ-III series.

With Low-backlash Gears External Dimensions Units: mm

● Flange Output Face

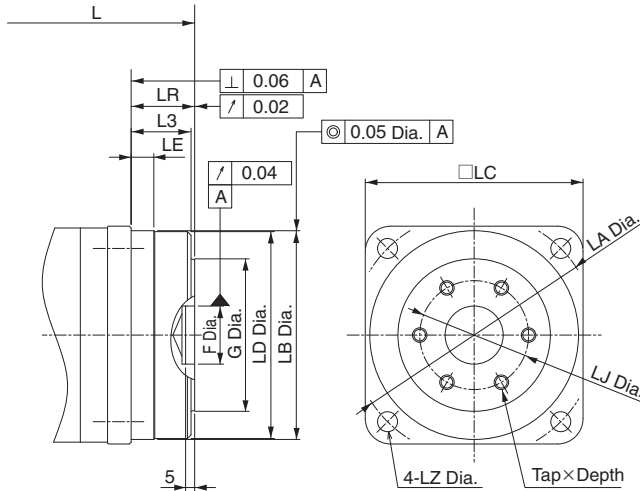

Model SGMAV-	Gear Ratio	L	LR	LJ	F	G	No. of pcs Tap x Depth	Approx. Mass kg
08A□AH101 (08A□AH10C)	1/5	220 (265)	27	45	24 ^{+0.021} ₀	59	6-M6×10L	4.8 (5.7)
08A□AHB01 (08A□AHB0C)	1/11							5.0 (5.9)
08A□AHC01 (08A□AHC0C)	1/21	254 (299)	35	60	32 ^{+0.025} ₀	84	6-M8×12L	8.7 (9.6)
08A□AH701 (08A□AH70C)	1/33							
10A□AH101 (10A□AH10C)	1/5	250 (300)	27	45	24 ^{+0.021} ₀	59	6-M6×10L	6.1 (7.1)
10A□AHB01 (10A□AHB0C)	1/11							
10A□AHC01 (10A□AHC0C)	1/21	284 (334)	35	60	32 ^{+0.025} ₀	84	6-M8×12L	10.0 (11.0)
10A□AH701 (10A□AH70C)	1/33							

Notes: 1 The models and values in parentheses are for servomotors with holding brakes.
2 The dimensions not given on the table above are the same as those in the table on the previous page.

Rotary Servomotors

SGMPS



Model Designations

• Without Gears

SGMPS - 01 A C A 2 1 - E

Σ-III Series
Servomotor
SGMPS

1st+2nd
digits

3rd
digit

4th
digit

5th
digit

6th
digit

7th
digit

8th
digit

1st+2nd digits Rated Output

Code	Specifications
01	100 W
02	200 W
04	400 W
08	750 W
15	1.5 kW

3rd digit Power Supply Voltage

Code	Specifications
A	200 VAC

4th digit Serial Encoder

Code	Specifications
2	17-bit absolute (standard)
C	17-bit incremental (standard)

5th digit Design Revision Order

Code	Specifications
A	IP55 (Standard)
E	IP67 (Optional)

6th digit Shaft End

Code	Specifications
2	Straight without key (standard)
6	Straight with key and tap (optional)

7th digit Options

Code	Specifications
1	Without options
C	With holding brake (24 VDC)
E	With oil seal and holding brake (24 VDC)
S	With oil seal

8th digit RoHS Directive

Code	Specifications
E	RoHS Compliant

Features

- Medium inertia
- Flat type
- Mounted high-resolution serial encoder: 17 bits
- Maximum speed: 6,000 min⁻¹
- Wide selection: 100 W to 1.5 kW capacity, holding brake and gear options
- Standard protection level: IP55 (IP67 available on request)

Application Examples

- Semiconductor equipment
- Chip mounters
- PCB drilling stations
- Robots
- Material handling machines
- Food processing equipment

● With Gears

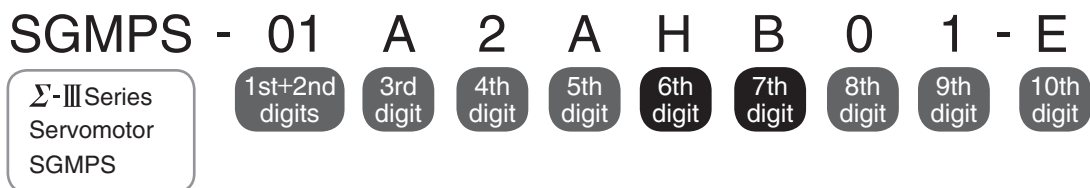

1st+2nd digits Rated Output

Code	Specifications
01	100 W
02	200 W
04	400 W
08	750 W
15	1.5 kW

3rd digit Power Supply Voltage

Code	Specifications
A	200 VAC

4th digit Serial Encoder

Code	Specifications
2	17-bit absolute (standard)
C	17-bit incremental (standard)

5th digit Design Revision Order

Code	Specifications
A	IP55 (Standard)

6th digit Gear Type

Code	Specifications
H	HDS planetary low-backlash gear

7th digit Gear Ratio

Code	Specifications
B	1/11
C	1/21
1	1/5
7	1/33

8th digit Shaft End

Code	Specifications
0	Flange output
2	Straight without key
6	Straight with key and tap (Optional)

9th digit Options

Code	Specifications
1	Without holding brake
C	With holding brake (24 VDC)

10th digit RoHS Directive

Code	Specifications
E	RoHS Compliant

Ratings and Specifications

Time Rating: Continuous
Vibration Class: V15
Insulation Resistance: 500 VDC, 10 MΩ min.
Ambient Temperature: 0 to 40°C
Excitation: Permanent magnet
Mounting: Flange-mounted
Thermal Class: B

Withstand Voltage: 1500 VAC for one minute
Enclosure: Totally enclosed, self-cooled, IP55
 (except for shaft opening)
Ambient Humidity: 20% to 80% (no condensation)
Drive Method: Direct drive
Rotation Direction: Counterclockwise (CCW) with forward run
 reference when viewed from the load side

Voltage		200 V				
Servomotor Model: SGMPS-□□□□		01A	02A	04A	08A	15A
Rated Output*1	W	100	200	400	750	1500
Rated Torque*1, *2	N·m	0.318	0.637	1.27	2.39	4.77
Instantaneous Peak Torque*1	N·m	0.955	1.91	3.82	7.16	14.3
Rated Current*1	Arms	0.86	2.0	2.6	5.4	9.2
Instantaneous Max. Current*1	Arms	2.8	6.4	8.4	16.5	28.0
Rated Speed*1	min ⁻¹	3000				
Max. Speed*1	min ⁻¹	6000				
Torque Constant	N·m/Arms	0.401	0.361	0.524	0.476	0.559
Rotor Moment of Inertia	×10 ⁻⁴ kg·m ²	0.0592 (0.0892)	0.263 (0.415)	0.409 (0.561)	2.10 (2.98)	4.02 (4.90)
Rated Power Rate*1	kW/s	17.1	15.4	39.6	27.2	56.6
Rated Angular Acceleration*1	rad/s ²	53700	24200	31100	11400	11900
Applicable SERVOPACK	SGDV-□□□□	R90□	2R8A, 2R1F	2R8□	5R5A	120A

*1: These items and torque-motor speed characteristics quoted in combination with an SGDV SERVOPACK are at an armature winding temperature of 100°C. Other values quoted are at 20°C.

*2: Rated torques are continuous allowable torque values at 40°C with an aluminum heat sink of the following dimensions attached.
 SGMPS-01, 02, 04 : 250 mm×250 mm×6 mm
 SGMPS-08, 15 : 300 mm×300 mm×12 mm

Note: The values in parentheses are for servomotors with holding brakes.

● Torque-Motor Speed Characteristics A: Continuous Duty Zone B: Intermittent Duty Zone ^(Note 3)

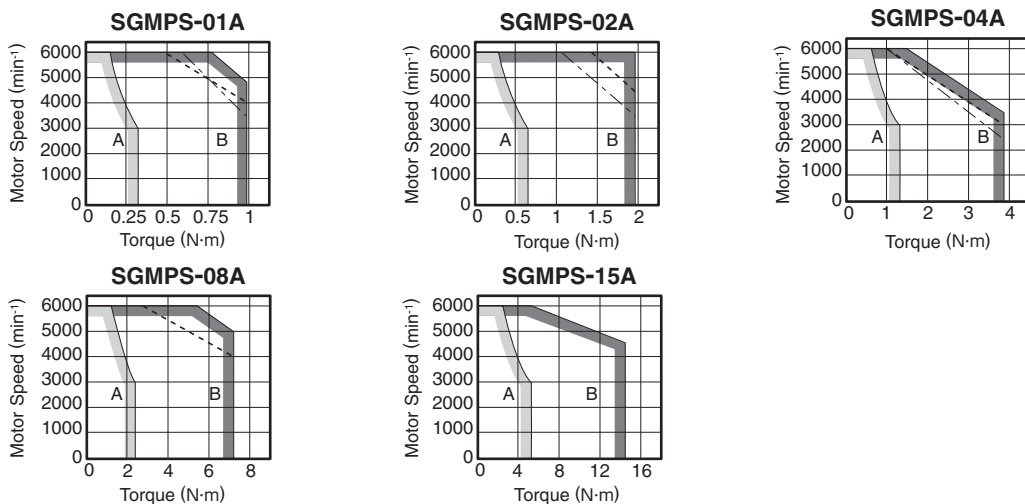

Notes: 1 The solid, dotted, and dashed-dotted lines of the intermittent duty zone indicate the characteristics when a servomotor runs in the following combinations:

- The solid line: With a three-phase 200 V or a single-phase 230 V
- The dotted line: With a single-phase 200 V
- The dashed-dotted line: With a single-phase 100 V

2 The characteristics of the intermittent duty zone differ depending on the supply voltages.

3 When the effective torque during intermittent duty is within the rated torque, the servomotor can be used within the intermittent duty zone.

4 When the main circuit cable length exceeds 20 m, note that the intermittent duty zone of the *Torque-Motor Speed Characteristics* will shrink as the line-to-line voltage drops.

Ratings and Specifications

● Derating Rate for Servomotor Fitted with an Oil Seal

When a motor is fitted with an oil seal, use the following derating rate because of the higher friction torque.

Servomotor Model SGMPS-	01A	02A	04A	08A	15A
Derating Rate %	90		95		

● Holding Brake Electrical Specifications

Holding Brake Rated Voltage	Servomotor Model	Servomotor Rated Output W	Holding Brake Specifications					
			Capacity W	Holding Torque N·m	Coil Resistance Ω (at 20°C)	Rated Current A(at 20°C)	Brake Release Time ms	Brake Operation Time ms
24 VDC ^{+10%} ₀	SGMPS-01A	100	7.8	0.318	71.6	0.34	20	100
	SGMPS-02A	200	7.6	0.637	74.2	0.32	40	100
	SGMPS-04A	400	8.2	1.27	70.9	0.32	40	100
	SGMPS-08A	750	7.5	2.39	58	0.31	20	100
	SGMPS-15A	1500	10	4.77	57.6	0.31	20	100

Notes: 1 The holding brake is only used to hold the load and cannot be used to stop the servomotor.

2 The holding brake open time and holding brake operation time vary depending on which discharge circuit is used. Make sure holding brake open time and holding brake operation time are correct for your servomotor.

● Overload Characteristics

The overload detection level is set under hot start conditions at a servomotor ambient temperature of 40°C.

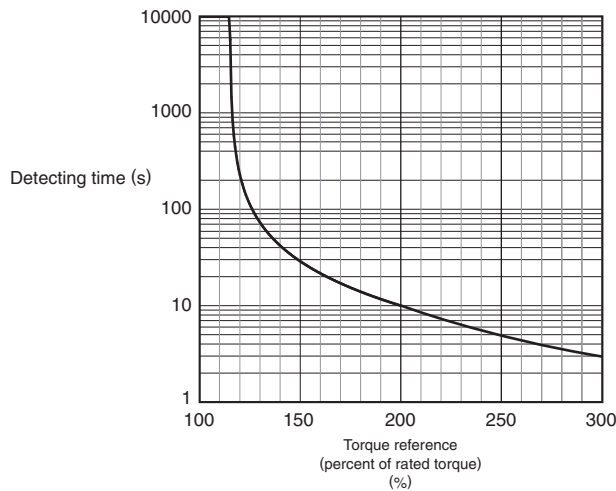

Note: Overload characteristics shown above do not guarantee continuous duty of 100% or more output. Use a servomotor with effective torque within the continuous duty zone of *Torque-Motor Speed Characteristics*.

Ratings and Specifications

● Allowable Load Moment of Inertia at the Motor Shaft

The rotor moment of inertia ratio is the value for a servomotor without a gear and a holding brake.

Servomotor Model		Servomotor Rated Output	Allowable Load Moment of Inertia (Rotor Moment of Inertia Ratio)
SGMPS-	01	100 W	25 times
	02	200 W	15 times
	04	400 W	7 times
	08	750 W	5 times
	15	1500 W	

● Load Moment of Inertia

The larger the load moment of inertia, the worse the movement response.

The allowable load moment of inertia (J_L) depends on the motor capacity, as shown above. This value is provided strictly as a guideline and results may vary depending on servomotor drive conditions.

Use the AC servo drive capacity selection program SigmaJunmaSize+ to check the operation conditions.

The program can be downloaded for free from our web site (<http://www.e-mechatronics.com/>).

An overvoltage alarm (A.400) is likely to occur during deceleration if the load moment of inertia exceeds the allowable load moment of inertia. SERVOPACKs with a built-in regenerative resistor may generate a regenerative overload alarm (A.320). Take one of the following steps if this occurs.

- Reduce the torque limit.
- Reduce the deceleration rate.
- Reduce the maximum speed.
- Install an external regenerative resistor if the alarm cannot be cleared using the steps above. Refer to *Regenerative Resistors* on page 360.

Regenerative resistors are not built into SERVOPACKs for 400 W motors or less.

External regenerative resistors are required when this condition is exceeded or if the allowable loss capacity (W) of the built-in regenerative resistor is exceeded due to regenerative drive conditions when a regenerative resistor is already built in.

● Allowable Radial and Thrust Loads

Design the mechanical system so thrust and radial loads applied to the servomotor shaft end during operation fall within the ranges shown in the table.

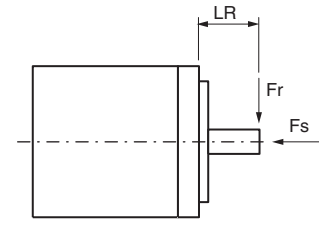
Servomotor Model		Allowable Radial Load (F_r) N	Allowable Thrust Load (F_s) N	LR mm	Reference Diagram
SGMPS-	01A	78	49	20	
	02A	245	68	25	
	04A				
	08A	392	147	35	
	15A	490	147	35	

External Dimensions Units: mm

(1) 100 to 400 W

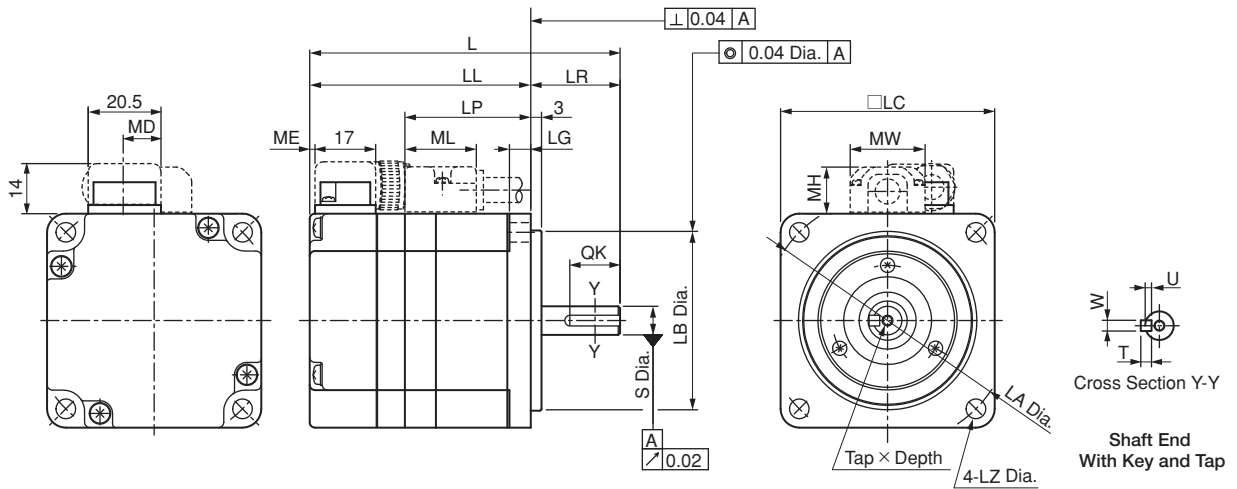

Model SGMPS-	L	LL	LP	LR	LC	LA	LB	LZ	LG	S	Tap x Depth	Key Dimensions				MD	ME	MH	ML	MW	Approx. Mass kg
												QK	U	W	T						
01A□A21-E (01A□A2C-E)	87 (115)	62 (90)	36	25	60	70	50 ⁰ _{-0.025}	5.5	6	8 ⁰ _{-0.009}	No tap	No key				9	1	12	20	19.8	0.5 (0.7)
01A□A61-E (01A□A6C-E)											M3×6L	14	1.8	3	3						
02A□A21-E (02A□A2C-E)	97 (128.5)	67 (98.5)	43	30	80	90	70 ⁰ _{-0.030}	7	8	14 ⁰ _{-0.011}	No tap	No key				14	1.5	13	21	21	1.1 (1.6)
02A□A61-E (02A□A6C-E)											M5×8L	16	3	5	5						
04A□A21-E (04A□A2C-E)	107 (138.5)	77 (108.5)	53	30	80	90	70 ⁰ _{-0.030}	7	8	14 ⁰ _{-0.011}	No tap	No key				14	1.5	13	21	21	1.4 (1.9)
04A□A61-E (04A□A6C-E)											M5×8L	16	3	5	5						

Note: The models and values in parentheses are for servomotors with holding brakes.

<Option>

● With an Oil Seal

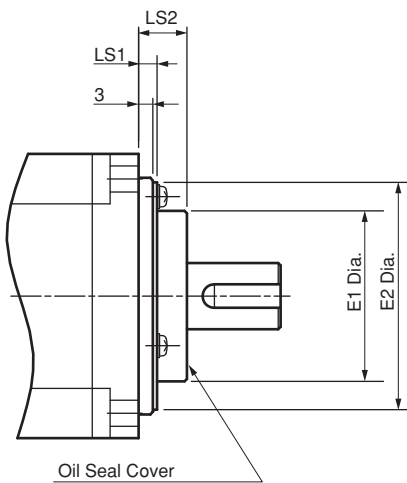

Model SGMPS-	Dimensions of Servomotor with an Oil Seal			
	E1	E2	LS1	LS2
01A	22	39	3.5	7
02A,04A	35	49	6.5	10

Note: The 7th digit of the model designation is "S" or "E."
The key dimensions are the same as those in the table above.

External Dimensions Units: mm

(2) 750 W, 1.5 kW

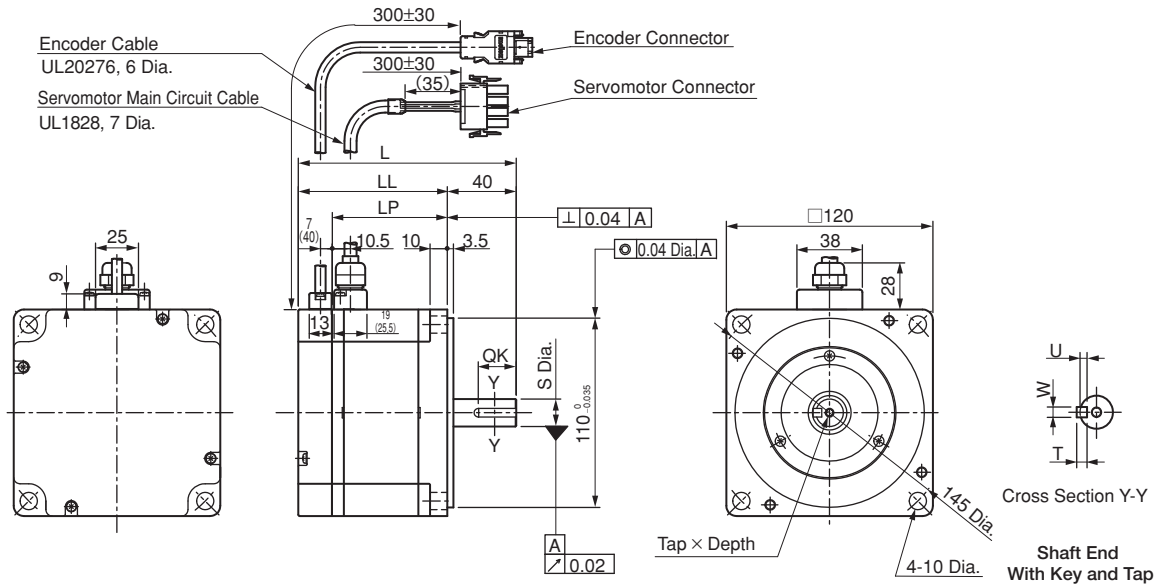

Model SGMPS-	L	LL	LP	S	Tap × Depth	Key Dimensions				Approx. Mass kg
						QK	U	W	T	
08A□A21-E (08A□A2C-E)	126.5 (160)	86.5 (120)	66.7	16 ⁰ _{-0.011}	No tap	No key				4.2 (5.7)
M5×8L					22	3	5	5		
15A□A21-E (15A□A2C-E)	154.5 (187.5)	114.5 (147.5)	94.7	19 ⁰ _{-0.013}	No tap	No key				6.6 (8.1)
M6×10L					22	3.5	6	6		

Note: The models and values in parentheses are for servomotors with holding brakes.

<Option>

●With an Oil Seal

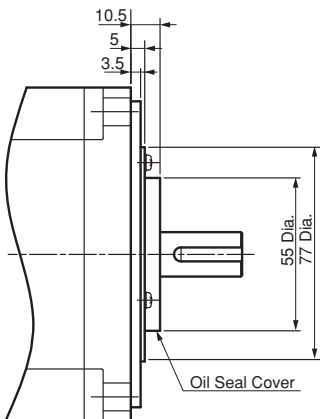

Selecting Cables

● Cables Connections

- Standard Wiring (Max. encoder cable length: 20 m)

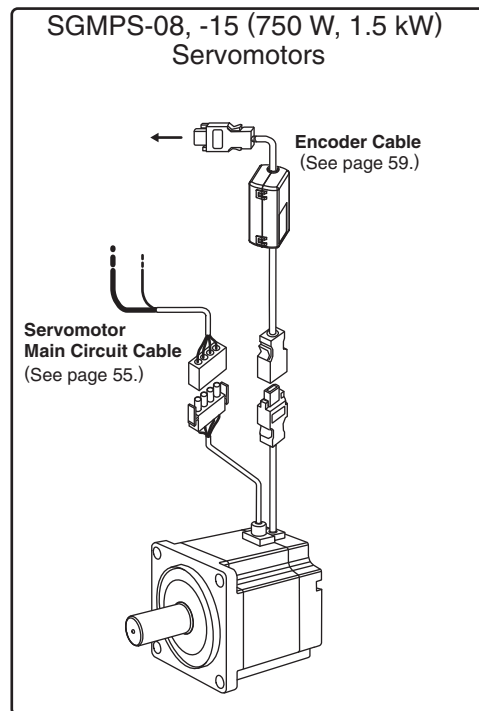
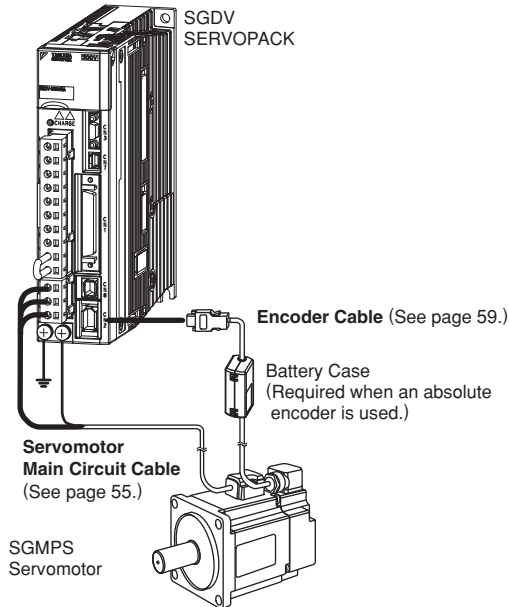

- Encoder Cable Extension from 30 to 50 m

(See page 62.)

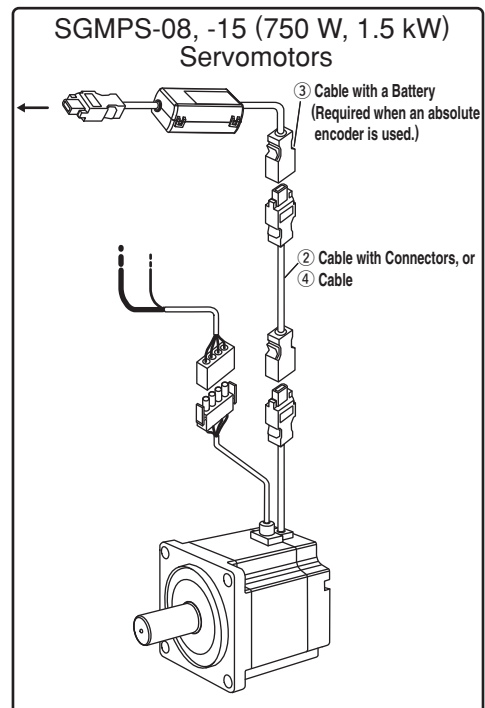
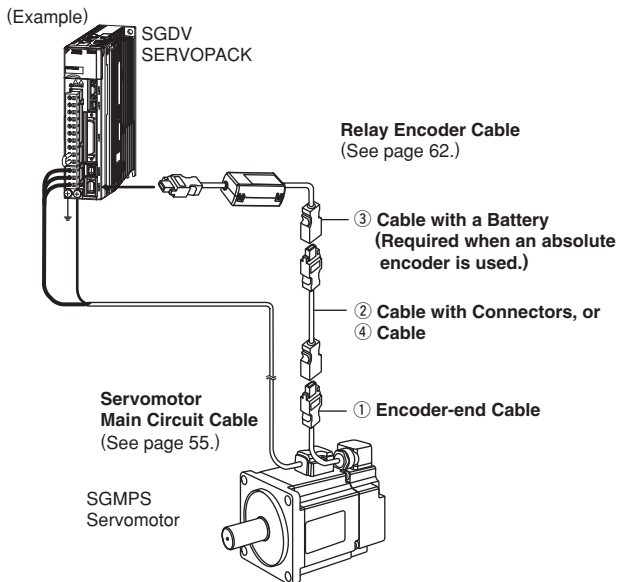

⚠ CAUTION

- Separate the servomotor main circuit cable wiring from the I/O signal cable and encoder cable at least 30 cm, and do not bundle or run them in the same duct.
- When the cable length exceeds 20 m, be sure to use a relay encoder cable.
- When the main circuit cable length exceeds 20 m, note that the intermittent duty zone of the *Torque-Motor Speed Characteristics* will shrink as the line-to-line voltage drops.

Selecting Cables

● Servomotor Main Circuit Cable



Name	Servomotor Rated Output	Length	Order No.		Specifications	Details		
			Standard Type	Flexible Type*				
For Servomotor without Holding Brakes	100 W	3 m	JZSP-CSM01-03-E	JZSP-CSM21-03-E		(1)		
		5 m	JZSP-CSM01-05-E	JZSP-CSM21-05-E				
		10 m	JZSP-CSM01-10-E	JZSP-CSM21-10-E				
		15 m	JZSP-CSM01-15-E	JZSP-CSM21-15-E				
		20 m	JZSP-CSM01-20-E	JZSP-CSM21-20-E				
		30 m	JZSP-CSM01-30-E	JZSP-CSM21-30-E				
		40 m	JZSP-CSM01-40-E	JZSP-CSM21-40-E				
	200 W, 400 W	3 m	JZSP-CSM02-03-E	JZSP-CSM22-03-E				
		5 m	JZSP-CSM02-05-E	JZSP-CSM22-05-E				
		10 m	JZSP-CSM02-10-E	JZSP-CSM22-10-E				
		15 m	JZSP-CSM02-15-E	JZSP-CSM22-15-E				
		20 m	JZSP-CSM02-20-E	JZSP-CSM22-20-E				
		30 m	JZSP-CSM02-30-E	JZSP-CSM22-30-E				
		40 m	JZSP-CSM02-40-E	JZSP-CSM22-40-E				
	750 W	3 m	JZSP-CMM00-03-E	JZSP-CMM01-03-E				(2)
		5 m	JZSP-CMM00-05-E	JZSP-CMM01-05-E				
		10 m	JZSP-CMM00-10-E	JZSP-CMM01-10-E				
		15 m	JZSP-CMM00-15-E	JZSP-CMM01-15-E				
		20 m	JZSP-CMM00-20-E	JZSP-CMM01-20-E				
		30 m	JZSP-CMM00-30-E	JZSP-CMM01-30-E				
		40 m	JZSP-CMM00-40-E	JZSP-CMM01-40-E				
1.5 kW	3 m	JZSP-CMM20-03-E	—					
	5 m	JZSP-CMM20-05-E	—					
	10 m	JZSP-CMM20-10-E	—					
	15 m	JZSP-CMM20-15-E	—					
	20 m	JZSP-CMM20-20-E	—					
For Servomotor with Holding Brakes	100 W	3 m	JZSP-CSM11-03-E	JZSP-CSM31-03-E		(3)		
		5 m	JZSP-CSM11-05-E	JZSP-CSM31-05-E				
		10 m	JZSP-CSM11-10-E	JZSP-CSM31-10-E				
		15 m	JZSP-CSM11-15-E	JZSP-CSM31-15-E				
		20 m	JZSP-CSM11-20-E	JZSP-CSM31-20-E				
		30 m	JZSP-CSM11-30-E	JZSP-CSM31-30-E				
		40 m	JZSP-CSM11-40-E	JZSP-CSM31-40-E				
	200 W, 400 W	3 m	JZSP-CSM12-03-E	JZSP-CSM32-03-E				
		5 m	JZSP-CSM12-05-E	JZSP-CSM32-05-E				
		10 m	JZSP-CSM12-10-E	JZSP-CSM32-10-E				
		15 m	JZSP-CSM12-15-E	JZSP-CSM32-15-E				
		20 m	JZSP-CSM12-20-E	JZSP-CSM32-20-E				
		30 m	JZSP-CSM12-30-E	JZSP-CSM32-30-E				
		40 m	JZSP-CSM12-40-E	JZSP-CSM32-40-E				
	750 W	3 m	JZSP-CMM10-03-E	JZSP-CMM11-03-E				(4)
		5 m	JZSP-CMM10-05-E	JZSP-CMM11-05-E				
		10 m	JZSP-CMM10-10-E	JZSP-CMM11-10-E				
		15 m	JZSP-CMM10-15-E	JZSP-CMM11-15-E				
		20 m	JZSP-CMM10-20-E	JZSP-CMM11-20-E				
		30 m	JZSP-CMM10-30-E	JZSP-CMM11-30-E				
		40 m	JZSP-CMM10-40-E	JZSP-CMM11-40-E				
1.5 kW	3 m	JZSP-CMM10-50-E	JZSP-CMM11-50-E					
	3 m	JZSP-CMM30-03-E	—					
	5 m	JZSP-CMM30-05-E	—					
	10 m	JZSP-CMM30-10-E	—					
	15 m	JZSP-CMM30-15-E	—					
20 m	JZSP-CMM30-20-E	—						

*: Use flexible cables for movable sections such as robot arms.

(Cont'd)

Selecting Cables

● Servomotor Main Circuit Cable (cont'd)

Name	Servomotor Rated Output	Length	Order No.		Specifications	Details
			Standard Type	Flexible Type*		
Servomotor-end Connector Kit	100 W		JZSP-CSM9-1-E		Crimping Type (A crimp tool is required.) 	(5)
	200 W, 400 W		JZSP-CSM9-2-E			(6)
	750 W, 1.5 kW (Without holding brake)		JZSP-CMM9-3-E		Crimping Type (A crimp tool is required.) 	(7)
	750 W, 1.5 kW (With holding brake)		JZSP-CSM9-5-E			
Cables	100 to 400 W	5 m	JZSP-CSM90-05-E	JZSP-CSM80-05-E		(8)
		10 m	JZSP-CSM90-10-E	JZSP-CSM80-10-E		
		15 m	JZSP-CSM90-15-E	JZSP-CSM80-15-E		
		20 m	JZSP-CSM90-20-E	JZSP-CSM80-20-E		
		30 m	JZSP-CSM90-30-E	JZSP-CSM80-30-E		
		40 m	JZSP-CSM90-40-E	JZSP-CSM80-40-E		
	750 W, 1.5 kW	5 m	JZSP-CSM91-05-E	JZSP-CSM81-05-E		(9)
		10 m	JZSP-CSM91-10-E	JZSP-CSM81-10-E		
		15 m	JZSP-CSM91-15-E	JZSP-CSM81-15-E		
		20 m	JZSP-CSM91-20-E	JZSP-CSM81-20-E		
		30 m	JZSP-CSM91-30-E	JZSP-CSM81-30-E		
		40 m	JZSP-CSM91-40-E	JZSP-CSM81-40-E		
		50 m	JZSP-CSM91-50-E	JZSP-CSM81-50-E		

*: Use flexible cables for movable sections such as robot arms.

(1) Wiring Specifications for Servomotors without Holding Brakes: 100 to 400 W

SERVOPACK-end Leads		Servomotor-end Connector	
Wire Color	Signal	Signal	Pin No.
Green/yellow	FG	FG	1
Blue	Phase W	Phase W	2
White	Phase V	Phase V	3
Red	Phase U	Phase U	4
		-	5
		-	6

(2) Wiring Specifications for Servomotors without Holding Brakes: 750 W, 1.5 kW

SERVOPACK-end Leads		Servomotor-end Connector	
Wire Color	Signal	Signal	Pin No.
Red	Phase U	Phase U	1
White	Phase V	Phase V	2
Blue	Phase W	Phase W	3
Green/yellow	FG	FG	4

(3) Wiring Specifications for Servomotor with Holding Brakes: 100 to 400 W

SERVOPACK-end Leads		Servomotor-end Connector	
Wire Color	Signal	Signal	Pin No.
Green/yellow	FG	FG	1
Blue	Phase W	Phase W	2
White	Phase V	Phase V	3
Red	Phase U	Phase U	4
Black	Brake	Brake	5
Black	Brake	Brake	6

Note: No polarity for connection to a holding brake.

(4) Wiring Specifications for Servomotor with Holding Brakes: 750 W, 1.5 kW

SERVOPACK-end Leads		Servomotor-end Connector	
Wire Color	Signal	Signal	Pin No.
Red	Phase U	Phase U	1
White	Phase V	Phase V	2
Blue	Phase W	Phase W	3
Green/yellow	FG	FG	4
Black	Brake	Brake	5
Black	Brake	Brake	6

Note: No polarity for connection to a holding brake.

Selecting Cables

(5) Servomotor-end Connector Kit Specifications: For 100 W Servomotors

Items		Specifications	External Dimensions mm
Order No.	JZSP-CSM9-1-E (Cables are not included.)		
Applicable Servomotors	SGMPS-01A		
Manufacturer	J.S.T. Mfg. Co., Ltd.		
Receptacle	J17-06FMH-7KL-1-CF		
Electrical Contact	SJ1F-01GF-P0.8		
Applicable Wire Size	AWG20 to 24		
Outer Diameter of Insulating Sheath	1.11 dia. to 1.53 dia. mm		
Crimp Tool	Hand tool	YRS-8841	
	Applicator	APLMK SJ1F/M-01-08	
Mounting Screw	M2 Pan-head screw		
Applicable Cable Outer Diameter	7±0.3 dia. mm		

(6) Servomotor-end Connector Kit Specifications: For 200, 400 W Servomotors

Items		Specifications	External Dimensions mm
Order No.	JZSP-CSM9-2-E (Cables are not included.)		
Applicable Servomotors	SGMPS-02A, -04A		
Manufacturer	J.S.T. Mfg. Co., Ltd.		
Receptacle	J27-06FMH-7KL-1-CF		
Electrical Contact	SJ2F-01GF-P1.0		
Applicable Wire Size	AWG20 to 24		
Outer Diameter of Insulating Sheath	1.11 dia. to 1.53 dia. mm		
Crimp Tool	Hand tool	YRS-8861	
	Applicator	APLMK SJ2F/M-01-08	
Mounting Screw	M2 Pan-head screw		
Applicable Cable Outer Diameter	7±0.3 dia. mm		

(7) Servomotor-end Connector Kit Specifications: For 750 W, 1.5 kW Servomotors

Items	Specifications		
	For Servomotors without Holding Brakes	For Servomotors with Holding Brakes	
		For power line	For brake line
Order No.	JZSP-CMM9-3-E	JZSP-CSM9-5-E	
Applicable Servomotors	SGMPS-08A, -15A		
Manufacturer	Tyco Electronics AMP K.K.		
Cap	350780-1	350781-1	
Socket	350550-6	350550-6	350689-3
Applicable Wire Size	AWG20 to 14	AWG20 to 14	AWG24 to 18
Crimp Tool	Hand tool	90296-2	90300-2
	Applicator	687763-2	466320-2
External Dimensions mm			

Selecting Cables

(8) Cable Specifications: For 100 to 400 W Servomotors

Items	Standard Type	Flexible Type
Order No.*	JZSP-CSM90-□□-E (50 m max.)	JZSP-CSM80-□□-E (50 m max.)
Specifications	UL2517 (Rating temperature: 105°C) AWG20×6C For power line: AWG20 (0.52 mm ²) Outer diameter of insulating sheath: 1.53 dia. mm For holding brake line: AWG20 (0.52 mm ²) Outer diameter of insulating sheath: 1.53 dia. mm	UL2517 (Rating temperature: 105°C) AWG22×6C For power line: AWG22 (0.33 mm ²) Outer diameter of insulating sheath: 1.37 dia. mm For holding brake line: AWG22 (0.33 mm ²) Outer diameter of insulating sheath: 1.37 dia. mm
Finished Dimensions	7±0.3 dia. mm	
Internal Configuration and Lead Color		
Yaskawa Standard Specifications (Standard Length)	Cable length: 5 m, 10 m, 15 m, 20 m, 30 m, 40 m, 50 m	

*: Specify the cable length in □□ of order no.
 Example: JZSP-CSM90-05-E (5 m)

(9) Cable Specifications: For 750 W, 1.5 kW Servomotors

Items	Standard Type	Flexible Type
Order No.*	JZSP-CSM91-□□-E (50 m max.)	JZSP-CSM81-□□-E (50 m max.)
Specifications	UL2517 (Rating temperature: 105°C) AWG16×4C, AWG20×2C For power line: AWG16 (1.31 mm ²) Outer diameter of insulating sheath: 2.15 dia. mm For holding brake line: AWG20 (0.52 mm ²) Outer diameter of insulating sheath: 1.6 dia. mm	UL2517 (Rating temperature: 105°C) AWG16×4C, AWG22×2C For power line: AWG16 (1.31 mm ²) Outer diameter of insulating sheath: 2.35 dia. mm For holding brake line: AWG22 (0.33 mm ²) Outer diameter of insulating sheath: 1.37 dia. mm
Finished Dimensions	8±0.3 dia. mm	
Internal Configuration and Lead Color		
Yaskawa Standard Specifications (Standard Length)	Cable length: 5 m, 10 m, 15 m, 20 m, 30 m, 40 m, 50 m	

*: Specify the cable length in □□ of order no.
 Example: JZSP-CSM91-05-E (5 m)

Selecting Cables

●Encoder Cables (Length: 20 m or less)

Name	Servo motor Capacity	Length	Order No.		Specifications	Details
			Standard Type	Flexible Type*		
Cable with Connectors (For Incremental Encoder)	100 to 400 W	3 m	JZSP-CSP01-03-E	JZSP-CSP21-03-E		(1)
		5 m	JZSP-CSP01-05-E	JZSP-CSP21-05-E		
		10 m	JZSP-CSP01-10-E	JZSP-CSP21-10-E		
		15 m	JZSP-CSP01-15-E	JZSP-CSP21-15-E		
		20 m	JZSP-CSP01-20-E	JZSP-CSP21-20-E		
	750 W, 1.5 kW	3 m	JZSP-CMP00-03-E	JZSP-CMP10-03-E		(2)
		5 m	JZSP-CMP00-05-E	JZSP-CMP10-05-E		
		10 m	JZSP-CMP00-10-E	JZSP-CMP10-10-E		
		15 m	JZSP-CMP00-15-E	JZSP-CMP10-15-E		
		20 m	JZSP-CMP00-20-E	JZSP-CMP10-20-E		
Cable with Connectors (For Absolute Encoder, with a Battery Case)	100 to 400 W	3 m	JZSP-CSP05-03-E	JZSP-CSP25-03-E		(3)
		5 m	JZSP-CSP05-05-E	JZSP-CSP25-05-E		
		10 m	JZSP-CSP05-10-E	JZSP-CSP25-10-E		
		15 m	JZSP-CSP05-15-E	JZSP-CSP25-15-E		
		20 m	JZSP-CSP05-20-E	JZSP-CSP25-20-E		
	750 W, 1.5 kW	3 m	JZSP-CSP19-03-E	JZSP-CSP29-03-E		(4)
		5 m	JZSP-CSP19-05-E	JZSP-CSP29-05-E		
		10 m	JZSP-CSP19-10-E	JZSP-CSP29-10-E		
		15 m	JZSP-CSP19-15-E	JZSP-CSP29-15-E		
		20 m	JZSP-CSP19-20-E	JZSP-CSP29-20-E		
SERVOPACK-end Connector Kit	100 W to 1.5 kW		JZSP-CMP9-1-E		Soldered 	(5)
Encoder-end Connector Kit	100 to 400 W		JZSP-CSP9-2-E		Crimping Type (A crimp tool is required.) 	
	750 W, 1.5 kW		JZSP-CMP9-2-E		Soldered 	
Cables		5 m	JZSP-CMP09-05-E	JZSP-CSP39-05-E	20 m Max. 	(6)
		10 m	JZSP-CMP09-10-E	JZSP-CSP39-10-E		
		15 m	JZSP-CMP09-15-E	JZSP-CSP39-15-E		
		20 m	JZSP-CMP09-20-E	JZSP-CSP39-20-E		

*: Use flexible cables for movable sections such as robot arms.

Note: When the battery from the host controller is used for the absolute encoder, no battery case is required. In this case, use a cable for the incremental encoders.

Selecting Cables

(1) Wiring Specifications for Cable with Connectors: 100 to 400 W (For incremental encoder)

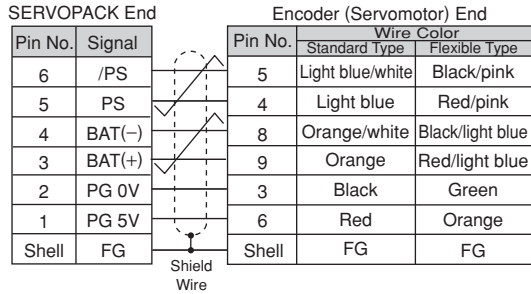

(2) Wiring Specifications for Cable with Connectors: 750 W, 1.5 kW (For incremental encoder)

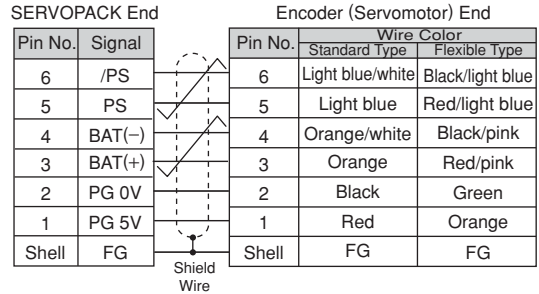

(3) Wiring Specifications for Cable with Connectors: 100 to 400 W (For absolute encoder, with a battery case)

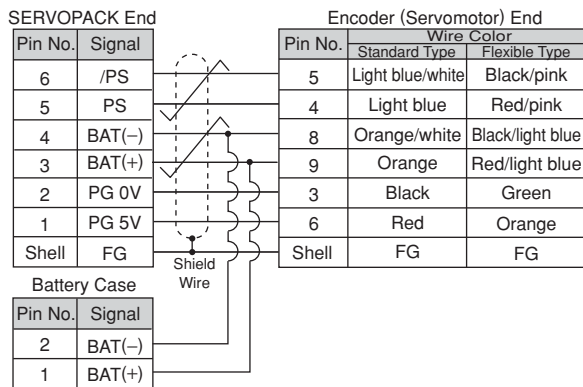

(4) Wiring Specifications for Cable with Connectors: 750 W, 1.5 kW (For absolute encoder, with a battery case)

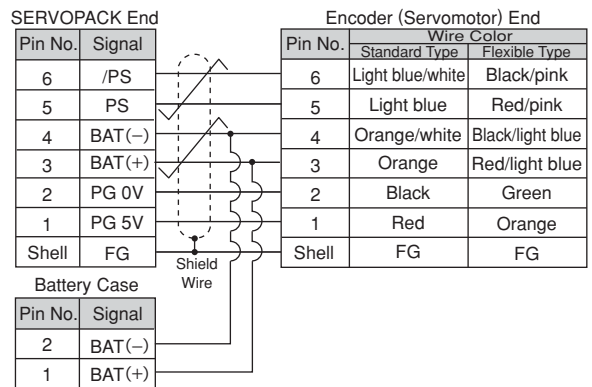

(5) SERVOPACK-end/Encoder-end Connector Kit Specifications

Items	SERVOPACK-end Connector Kit	Encoder-end Connector Kit	
Order No.	JZSP-CMP9-1-E (Cables are not included.)	JZSP-CSP9-2-E (Cables are not included.)	JZSP-CMP9-2-E (Cables are not included.)
Manufacturer	Molex Japan Co., Ltd.	Molex Japan Co., Ltd.	Molex Japan Co., Ltd.
Specifications	55100-0670 (soldered) Product Specification: PS-54280	54346-0070 (crimped)* Mounting screw: M2 pan-head screw (x2) Outer diameter of applicable cable: 6.3 dia. to 7.7 dia. mm Applicable wire size: AWG22 to 26 Outer diameter of insulating sheath: 1.05 dia. to 1.4 dia. mm Application Specification: AS-54992 Crimping Specification: CS-56161	54280-0609 (soldered) Product Specification: PS-54280
External Dimensions mm			

*: A crimp tool is required.

The following crimp tools are applicable for the cables provided by Yaskawa. When using other wire sizes, contact the respective manufacturer for crimp tools.
Applicable crimp tool for Yaskawa's wire size: Hand Tool Model No. 57175-5000
Applicator Model No. 57175-3000

Selecting Cables

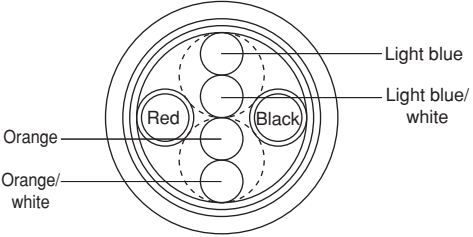
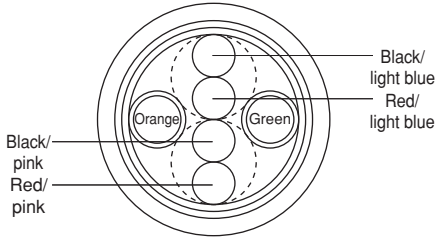

(6) Cable Specifications

Items	Standard Type	Flexible Type
Order No.*	JZSP-CMP09-□□-E	JZSP-CSP39-□□-E
Cable Length	20 m max.	
Specifications	UL20276 (Rating temperature: 80°C) AWG22×2C+AWG24×2P AWG22 (0.33 mm ²) Outer diameter of insulating sheath: 1.15 dia. mm AWG24 (0.20 mm ²) Outer diameter of insulating sheath: 1.09 dia. mm	UL20276 (Rating temperature: 80°C) AWG22×2C+AWG24×2P AWG22 (0.33 mm ²) Outer diameter of insulating sheath: 1.35 dia. mm AWG24 (0.20 mm ²) Outer diameter of insulating sheath: 1.21 dia. mm
Finished Dimensions	6.5 dia. mm	6.8 dia. mm
Internal Configuration and Lead Color		
Yaskawa Standards Specifications (Standard Length)	Cable length: 5 m, 10 m, 15 m, 20 m	

*: Specify the cable length in □□ of order no.
 Example: JZSP-CMP09-05-E (5 m)

Selecting Cables

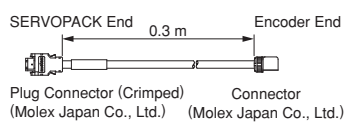
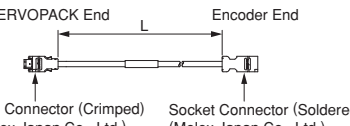
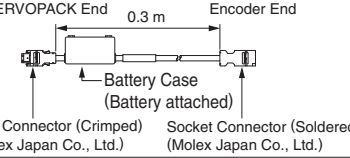
● Relay Encoder Cables (For extending from 30 to 50 m)

Name	Length	Order No. Standard Type	Specifications	Details
① Encoder-end Cables (For incremental and absolute encoder)	0.3 m	JZSP-CSP11-E		(1)
② Cable with Connectors (For incremental and absolute encoder)	30 m	JZSP-UCMP00-30-E		(2)
	40 m	JZSP-UCMP00-40-E		
	50 m	JZSP-UCMP00-50-E		
③ Cable with a Battery Case (Required when an absolute encoder is used)	0.3 m	JZSP-CSP12-E*		(3)
④ Cables	30 m	JZSP-CMP19-30-E		(4)
	40 m	JZSP-CMP19-40-E		
	50 m	JZSP-CMP19-50-E		

*: When using an incremental encoder or using an absolute encoder with a battery connected to the host controller, no battery case is required.

(1) Wiring Specifications for Encoder-end Cable

SERVOPACK End		Encoder (Servomotor) End	
Pin No.	Signal	Pin No.	Wire Color
6	/PS	5	Light blue/white
5	PS	4	Light blue
4	BAT (-)	8	Orange/white
3	BAT (+)	9	Orange
2	PG 0V	3	Black
1	PG 5V	6	Red
Shell	FG	Shell	FG

(2) Wiring Specifications for Cable with Connectors

SERVOPACK End		Encoder (Servomotor) End	
Pin No.	Signal	Pin No.	Wire Color
6	/PS	6	Light blue/white
5	PS	5	Light blue
4	BAT (-)	4	Orange/white
3	BAT (+)	3	Orange
2	PG 0V	2	Black
1	PG 5V	1	Red
Shell	FG	Shell	FG

(3) Wiring Specifications for Cable with a Battery Case

SERVOPACK End		Encoder (Servomotor) End	
Pin No.	Signal	Pin No.	Wire Color
6	/PS	6	Light blue/white
5	PS	5	Light blue
4	BAT (-)	4	Orange/white
3	BAT (+)	3	Orange
2	PG 0V	2	Black
1	PG 5V	1	Red
Shell	FG	Shell	FG

Battery Case	
Pin No.	Signal
2	BAT (-)
1	BAT (+)

(4) Cable Specifications

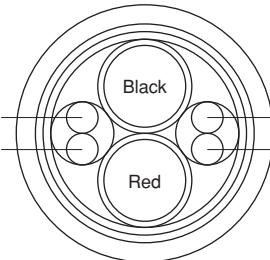
Item	Standard Type
Order No.*	JZSP-CMP19-□□-E
Cable Length	50 m max.
Specifications	UL20276 (Rating temperature: 80°C) AWG16×2C+AWG26×2P AWG16 (1.31 mm ²) Outer diameter of insulating sheath: 2.0 dia. mm AWG26 (0.13 mm ²) Outer diameter of insulating sheath: 0.91 dia. mm
Finished Dimensions	6.8 dia. mm
Internal Configuration and Lead Colors	
Yaskawa Standard Specifications (Standard Length)	Cable length: 30 m, 40 m, 50 m

*: Specify the cable length in □□ of order no.
Example: JZSP-CMP19-30-E (30 m)

With Low-backlash Gears

Ratings and Specifications

Time Rating: Continuous
Insulation Resistance: 500 VDC, 10 MΩ min.
Ambient Temperature: 0 to 40°C
Excitation: Permanent magnet
Mounting: Flange-mounted
Gear Mechanism: Planetary gear mechanism
Thermal Class: B

Withstand Voltage: 1500 VAC for one minute
Enclosure: Totally enclosed, self-cooled, IP55
 (except for shaft opening)
Ambient Humidity: 20% to 80% (no condensation)
Drive Method: Direct drive
Rotation Direction: Counterclockwise (CCW) with forward run
 reference when viewed from the load side

Servomotor Model SGMPS-	Servomotor			Gear					
	Rated Output W	Rated Speed min ⁻¹	Rated Torque N·m	Gear Ratio	Lost Motion arc-min	Rated Torque / Efficiency* ¹ N·m / %	Instantaneous Peak Torque N·m	Rated Speed min ⁻¹	Max. Speed* ² min ⁻¹
01A□AH1□	100	3000	0.318	1/5	3 max.	1.27/80	4.34	600	800
01A□AHB□				1/11		2.80/80	9.55	273	363
01A□AHC□				1/21		5.34/80	18.2	143	190
01A□AH7□				1/33		8.40/80	28.7	91	121
02A□AH1□	200	3000	0.637	1/5	3 max.	2.55/80	8.40	600	800
02A□AHB□				1/11		5.96/85	19.3	273	363
02A□AHC□				1/21		11.4/85	37.3	143	190
02A□AH7□				1/33		17.9/85	58.6	91	121
04A□AH1□	400	3000	1.27	1/5	3 max.	5.40/85	17.6	600	800
04A□AHB□				1/11		11.9/85	39.1	273	363
04A□AHC□				1/21		22.7/85	72.2	143	190
04A□AH7□				1/33		33.5/80	115	91	121
08A□AH1□	750	3000	2.39	1/5	3 max.	10.2/85	33.3	600	800
08A□AHB□				1/11		22.3/85	71.0	273	363
08A□AHC□				1/21		42.7/85	140	143	190
08A□AH7□				1/33		67.0/85	206	91	121
15A□AH1□	1500	3000	4.77	1/5	3 max.	20.3/85	65.9	600	800
15A□AHB□				1/11		44.6/85	148	273	363
15A□AHC□				1/21		80.1/80	270	143	190
15A□AH7□				1/33		126/80	353* ³	91	121

*1: Gear output torque is expressed using the following equation.

$$(\text{Gear output torque}) = (\text{Servomotor output torque}) \times \frac{1}{(\text{gear ratio})} \times (\text{efficiency})$$

Gear efficiency depends on operating conditions such as rated output, motor speed, and temperature etc. The values in the table are representative values with rated output, rated speed, and an ambient temperature of 25°C, and are not guaranteed values.

*2: Max. speed is up to 4000 min⁻¹ at the shaft.

*3: The instantaneous peak torque values indicated with *3 are limited by the gear, so use the following servomotor instantaneous peak torque. In this case, set torque limit parameters Pn402 and 403 for the SERVOPACK at 250%

Notes: 1 The gear mounted to our servomotor has not been broken in. Break in the servomotor if necessary. First, run the motor at low speed with no load. If no problems arise, gradually increase the speed and load.

2 The no-load torque for a servomotor with a gear is high immediately after the servomotor starts, and it then decreases and becomes stable a few minutes later. This is a common phenomenon caused by grease being circulated in the gear and not by a faulty gear.

IMPORTANT The SERVOPACK speed control range is 5000:1. When using servomotors at extremely low speeds (0.02 min⁻¹ at gear output shaft), or when using servomotors with 1 pulse feed reference for extended periods etc., the gear bearing lubrication may be insufficient. That may cause deterioration of bearing or increase the load ratio.
Contact your Yaskawa representative if you are using your servomotor under these conditions.

With Low-backlash Gears Ratings and Specifications

● **Moment of Inertia and Allowable Radial and Thrust Loads**

Servomotor Model SGMPS-	Moment of Inertia ×10 ⁻⁴ kg·m ²		Servomotors with Low-backlash Gears			Reference Diagram
	Motor + Gear	Gear	Allowable Radial Load (Fr) N	Allowable Thrust Load (Fs) N	LR mm	
01A□AH1□	0.152	0.093	167	147	55	
01A□AHB□	0.107	0.048	216			
01A□AHC□	0.102	0.043	392	235	69	
01A□AH7□	0.092	0.033	431			
02A□AH1□	0.623	0.360	245	235	69	
02A□AHB□	0.351	0.088	323			
02A□AHC□	0.373	0.110	549	294	79	
02A□AH7□	0.328	0.065	608			
04A□AH1□	0.769	0.360	245	235	69	
04A□AHB□	0.604	0.195	441	294	79	
04A□AHC□	0.604	0.195	568	314	100	
04A□AH7□	0.582	0.173	657			
08A□AH1□	2.87	0.765	343	294	79	
08A□AHB□	2.62	0.523	451	314	100	
08A□AHC□	2.76	0.663	813	490	137	
08A□AH7□	2.56	0.455	921			
15A□AH1□	5.56	1.540	353	314	137	
15A□AHB□	6.11	2.090	647	490		
15A□AHC□	6.00	1.980	1274	882	151	
15A□AH7□	5.14	1.116				

IMPORTANT

The gear generates the loss at gear mechanism and oil seal. The loss varies with torque and motor speed conditions. The temperature rise depends on heating conditions. Always check the actual gear and motor temperature. If the temperature is high, take the measures shown below.

- Decrease the load ratio.
- Change the heating conditions.
- Cool the motor with a cooling fan etc.

Rated Output W	Heat Sink Size				
	1/5	1/11	1/21	1/33	
100	A				
200	B				
400					
750					C
1500					

- A : 250 mm×250 mm×6 mm, aluminum
- B : 300 mm×300 mm×12 mm, aluminum
- C : 350 mm×350 mm×12 mm, aluminum

With Low-backlash Gears

External Dimensions Units: mm

(1) 100 to 400 W

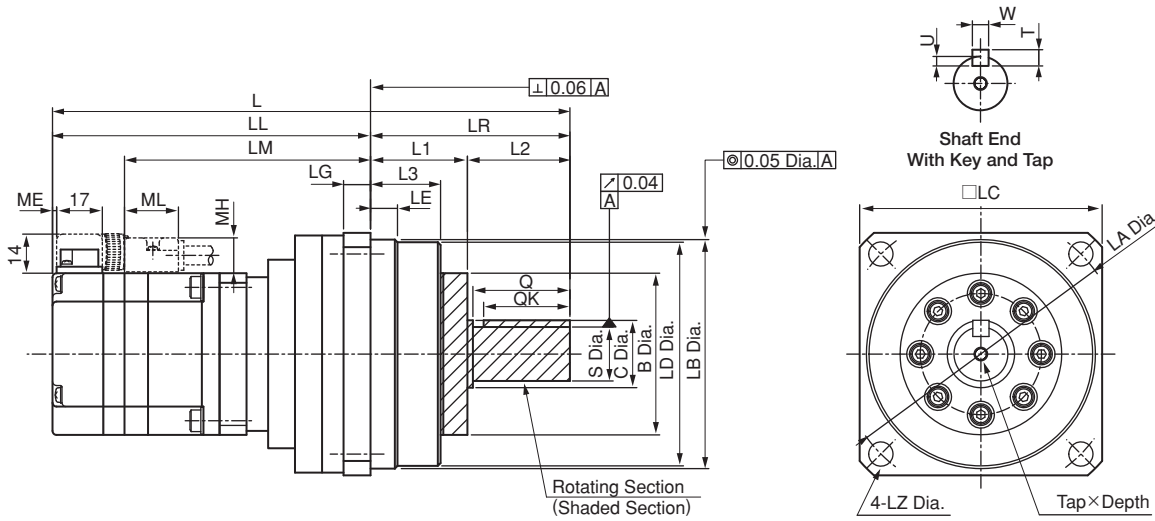

Model SGMPS-	Gear Ratio	L	LL	LM	LR	LE	LG	B	C	LD	LB	LC	LA	LZ	L1	L2	L3	Q	S	Tap× Depth	Key Dimensions					ME	MH	ML	Approx. Mass kg				
																					QK	U	W	T									
01A□AH1※1-E (01A□AH1※C-E)	1/5	168	108	82	60	8	9	40	20	64.5	65 ⁰ _{-0.030}	70	80	6.6	30	30	22	28	16 ⁰ _{-0.016}	M4×8L	25	3	5	5	1	12	20	1.3 (1.5)					
01A□AHB※1-E (01A□AHB※C-E)	1/11	(196)	(136)																														
01A□AHC※1-E (01A□AHC※C-E)	1/21	191	117	91	74	7.5	10	59	26	84	85 ⁰ _{-0.035}	90	105	9	36	38	26	36	20 ⁰ _{-0.021}	M5×10L	32	3.5	6	6	1	12	20	2.8 (3.0)					
01A□AH7※1-E (01A□AH7※C-E)	1/33	(219)	(145)																														
02A□AH1※1-E (02A□AH1※C-E)	1/5	197	123	99	74	7.5	10	59	26	84	85 ⁰ _{-0.035}	90	105	9	36	38	26	36	20 ⁰ _{-0.021}	M5×10L	32	3.5	6	6	1.5	13	21	3.2 (3.7)					
02A□AHB※1-E (02A□AHB※C-E)	1/11	(228.5)	(154.5)																														
02A□AHC※1-E (02A□AHC※C-E)	1/21	215	131	107	84	12	12	59	32	96	100 ⁰ _{-0.035}	105	120	9	40	44	29	42	25 ⁰ _{-0.021}	M6×12L	36	4	8	7	1.5	13	21	3.8 (4.3)					
02A□AH7※1-E (02A□AH7※C-E)	1/33	(246.5)	(162.5)																														
04A□AH1※1-E (04A□AH1※C-E)	1/5	207	133	109	74	7.5	10	59	26	84	85 ⁰ _{-0.035}	90	105	9	36	38	26	36	20 ⁰ _{-0.021}	M5×10L	32	3.5	6	6	1.5	13	21	3.5 (4.0)					
04A□AHB※1-E (04A□AHB※C-E)	1/11	225	141	117	84	12	12	59	32	96	100 ⁰ _{-0.035}	105	120	9	40	44	29	42	25 ⁰ _{-0.021}	M6×12L	36	4	8	7	1.5	13	21	4.1 (4.6)					
04A□AHC※1-E (04A□AHC※C-E)	1/21	253	148	124	105	14	13	59	40	112	115 ⁰ _{-0.035}	120	135	11	45	60	33	58	32 ⁰ _{-0.025}	M8×16L	50	5	10	8	1.5	13	21	4.5 (5.0)					
04A□AH7※1-E (04A□AH7※C-E)	1/33	254	149	125	105	12.5	13	84	40	114	115 ⁰ _{-0.035}	120	135	11	45	60	33	58	32 ⁰ _{-0.025}	M8×16L	50	5	10	8	1.5	13	21	7.0 (7.5)					

: The asterisk () describes the values of the 8th digit of the model designation, "shaft end code 6 (straight with key and tap)." If a key or tap is not necessary, order a servomotor with "shaft end code 2 (without key and tap)."
 Note: The models and values in parentheses are for servomotors with holding brakes.

With Low-backlash Gears External Dimensions Units: mm

(2) 750 W, 1.5 kW

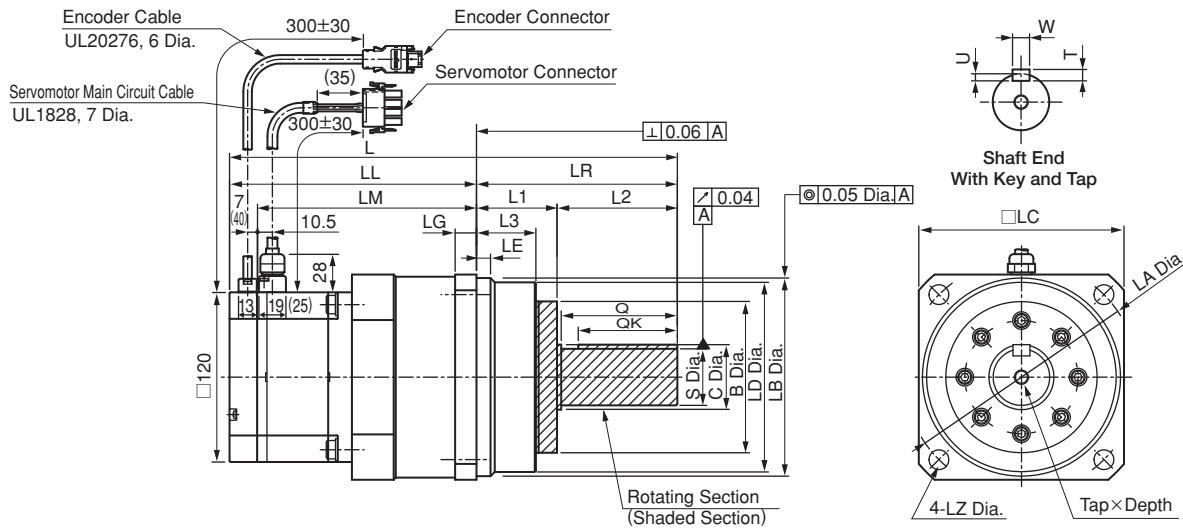

Model SGMPS-	Gear Ratio	L	LL	LM	LR	LE	LG	B	C	LD	LB	LC	LA	LZ	L1	L2	L3	Q	S	Tap x Depth	Key Dimensions				Approx. Mass kg	
																					QK	U	W	T		
08A□AH1※1-E (08A□AH1※C-E)	1/5	234.5 (268)	150.5 (184)	131	84	12	12	59	32	96	100 ⁰ _{-0.035}	105	120	9	40	44	29	42	25 ⁰ _{-0.021}	M6×12L	36	4	8	7	6.9 (8.4)	
08A□AHB※1-E (08A□AHB※C-E)	1/11	263.5 (297)	158.5 (192)	139	105	14	13	59	40	112	115 ⁰ _{-0.035}	120	135	11	45	60	33	58	32 ⁰ _{-0.025}	M8×16L	50	5	10	8	8.0 (9.5)	
08A□AHC※1-E (08A□AHC※C-E)	1/21	316.5 (350)	174.5 (208)	155	142	10	15	84	44	134	140 ⁰ _{-0.040}	145	165	14	57	85	40	82	40 ⁰ _{-0.025}	M10×20L	70	5	12	8	11.0 (12.5)	
08A□AH7※1-E (08A□AH7※C-E)	1/33	291.5 (325)	186.5 (220)	167	105	12.5	13	84	40	114	115 ⁰ _{-0.035}	120	135	11	45	60	33	58	32 ⁰ _{-0.025}	M8×16L	50	5	10	8	13.1 (10.7)	
15A□AH1※1-E (15A□AH1※C-E)	1/5	344.5 (378)	202.5 (236)	183	142	10	15	84	44	134	140 ⁰ _{-0.040}	145	165	14	57	85	40	82	40 ⁰ _{-0.025}	M10×20L	70	5	12	8	11.3 (12.8)	
15A□AHB※1-E (15A□AHB※C-E)	1/11	364.5 (398)	208.5 (242)	189	156	16	16	135	51	163	165 ⁰ _{-0.040}	170	190	14	70	86	51	82	45 ⁰ _{-0.025}	M10×20L	70	5.5	14	9	23.6 (25.1)	
15A□AHC※1-E (15A□AHC※C-E)	1/21																									
15A□AH7※1-E (15A□AH7※C-E)	1/33																									

※: The asterisk (※) describes the values of the 8th digit of the model designation, "shaft end code 6 (straight with key and tap)." If a key or tap is not necessary, order a servomotor with "shaft end code 2 (without key and tap)."

Note: The models and values in parentheses are for servomotors with holding brakes.

Flange-type With Low-backlash Gears

Ratings and Specifications

Time Rating: Continuous
Insulation Resistance: 500 VDC, 10 MΩ min.
Ambient Temperature: 0 to 40°C
Excitation: Permanent magnet
Mounting: Flange-mounted
Gear Mechanism: Planetary gear mechanism
Thermal Class: B

Withstand Voltage: 1500 VAC for one minute
Enclosure: Totally enclosed, self-cooled, IP55
 (except for shaft opening)
Ambient Humidity: 20% to 80% (no condensation)
Drive Method: Direct drive
Rotation Direction: Counterclockwise (CCW) with forward run
 reference when viewed from the load side

Servomotor Model SGMPS-	Servomotor			Gear					
	Rated Output W	Rated Speed min ⁻¹	Rated Torque N·m	Gear Ratio	Lost Motion arc-min	Rated Torque / Efficiency*1 N·m/%	Instantaneous Peak Torque N·m	Rated Speed min ⁻¹	Max. Speed*2 min ⁻¹
01A□AH10	100	3000	0.318	1/5	3	1.27/80	4.32	600	800
01A□AHB0				1/11		2.80/80	9.5	273	363
01A□AHC0				1/21		5.34/80	18.1	143	190
01A□AH70				1/33		8.40/80	27.0	91	121
02A□AH10	200	3000	0.637	1/5	3	2.55/80	8.6	600	800
02A□AHB0				1/11		5.62/80	18.9	273	363
02A□AHC0				1/21		10.7/80	36.1	143	190
02A□AH70				1/33		16.8/80	48.0*3	91	121
04A□AH10	400	3000	1.27	1/5	3	5.08/80	17.2	600	800
04A□AHB0				1/11		11.2/80	35.0	273	363
04A□AHC0				1/21		21.3/80	72.2	143	190
04A□AH70				1/33		33.5/80	93.0*3	91	121
08A□AH10	750	3000	2.39	1/5	3	9.56/80	32.0	600	800
08A□AHB0				1/11		21.0/80	56.0*3	273	363
08A□AHC0				1/21		40.2/80	134	143	190
08A□AH70				1/33		63.1/80	156*3	91	121
15A□AH10	1500	3000	4.77	1/5	3	19.1/80	64.4	600	800
15A□AHB0				1/11		42.0/80	142	272	363
15A□AHC0				1/21		80.1/80	270	143	190
15A□AH70				1/33		126/80	353*3	91	121

*1: Gear output torque is expressed using the following equation.

$$(\text{Gear output torque}) = (\text{Servomotor output torque}) \times \frac{1}{(\text{gear ratio})} \times (\text{efficiency})$$

Gear efficiency depends on operating conditions such as rated output, motor speed, and temperature etc. The values in the table are representative values with rated output, rated speed, and an ambient temperature of 25°C, and are not guaranteed values.

*2: Max. speed is up to 4000 min⁻¹ at the shaft.

*3: The instantaneous peak torque values indicated with *3 are limited by the gear, so use the following servomotor instantaneous peak torque. In this case, set torque limit parameters Pn402 and 403 for the SERVOPACK at 250%.

Notes: 1 The gear mounted to our servomotor has not been broken in. Break in the servomotor if necessary. First, run the motor at low speed with no load. If no problems arise, gradually increase the speed and load.

2 The no-load torque for a servomotor with a gear is high immediately after the servomotor starts, and it then decreases and becomes stable a few minutes later. This is a common phenomenon caused by grease being circulated in the gear and not by a faulty gear.

IMPORTANT The SERVOPACK speed control range is 5000:1. When using servomotors at extremely low speeds (0.02 min⁻¹ at gear output shaft), or when using servomotors with 1 pulse feed reference for extended periods etc., the gear bearing lubrication may be insufficient. That may cause deterioration of bearing or increase the load ratio. Contact your Yaskawa representative if you are using your servomotor under these conditions.

Flange-type With Low-backlash Gears Ratings and Specifications

● **Moment of Inertia and Allowable Radial and Thrust Loads**

Servomotor Model SGMPS-	Moment of Inertia × 10 ⁻⁴ kg · m ²		Servomotors with Low-backlash Gears			Reference Diagram
	Motor + Gear	Gear	Allowable Radial Load (Fr) N	Allowable Thrust Load (Fs) N	LR mm	
01A□AH10	0.144	0.085	167	147	55	
01A□AHB0	0.100	0.041	216			
01A□AHC0	0.102	0.043	392	235	69	
01A□AH70	0.085	0.026	431			
02A□AH10	0.543	0.280	245	235	69	
02A□AHB0	0.364	0.101	323			
02A□AHC0	0.351	0.088	549	294	79	
02A□AH70	0.317	0.054	608			
04A□AH10	0.689	0.280	245	235	69	
04A□AHB0	0.636	0.227	441	294	79	
04A□AHC0	0.628	0.219	568	314	100	
04A□AH70	0.545	0.136	657			
08A□AH10	2.72	0.616	343	294	79	
08A□AHB0	2.65	0.552	451	314	100	
08A□AHC0	2.65	0.552	813	490	137	
08A□AH70	2.43	0.327	921			
15A□AH10	5.59	1.57	353	314	137	
15A□AHB0	5.58	1.56	647	490		
15A□AHC0	5.9	1.88	1274	882	151	
15A□AH70	5.1	1.08				

IMPORTANT The gear generates the loss at gear mechanism and oil seal. The loss varies with torque and motor speed conditions. The temperature rise depends on heating conditions. Always check the actual gear and motor temperature. If the temperature is high, take the measures shown below.

- Decrease the load ratio.
- Change the heating conditions.
- Cool the motor with a cooling fan etc.

Rated Output W	Heat Sink Size			
	1/5	1/11	1/21	1/33
100	A			
200	B			
400				
750				
1500	C			

A : 250 mm×250 mm×6 mm, aluminum
 B : 300 mm×300 mm×12 mm, aluminum
 C : 350 mm×350 mm×12 mm, aluminum

Flange-type With Low-backlash Gears

External Dimensions Units: mm

(1) 100 to 400 W

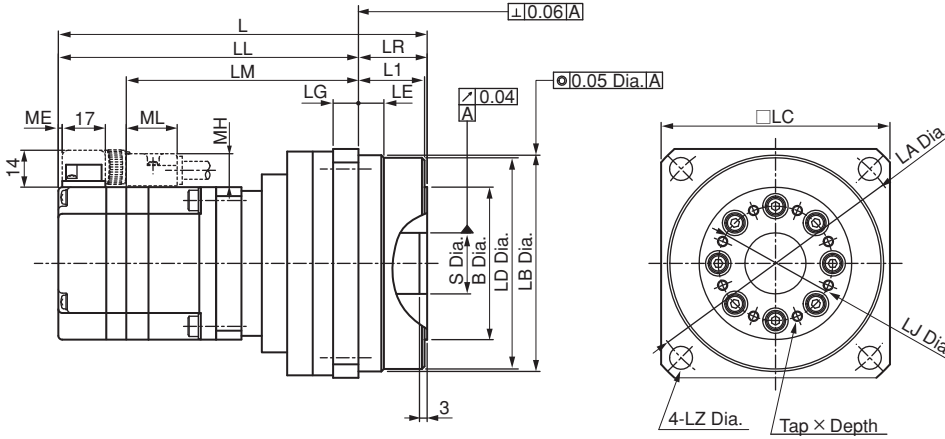

Model SGMPS-	Gear Ratio	L	LL	LM	LR	LE	LG	B	LD	LB	LC	LA	LZ	L1	S	Tap × Depth	LJ	ME	MH	ML	Approx. Mass kg
01A□AH101-E (01A□AH10C-E)	1/5	132	109	83	23	8	9	50	64.5	65 ⁰ _{-0.030}	70	80	6.6	22	19 ^{+0.021} ₀	M3 × 6L	35	1	12	20	1.3 (1.5)
01A□AHB01-E (01A□AHB0C-E)	1/11	(160)	(137)																		1.4 (1.6)
01A□AHC01-E (01A□AHC0C-E)	1/21	145	118	92	27	10	10	60	83	85 ⁰ _{-0.035}	90	105	9	26	24 ^{+0.021} ₀	M4 × 7L	45	1	12	20	2.4 (2.6)
01A□AH701-E (01A□AH70C-E)	1/33	(173)	(146)																		
02A□AH101-E (02A□AH10C-E)	1/5	150	123	99	27	10	10	60	83	85 ⁰ _{-0.035}	90	105	9	26	24 ^{+0.021} ₀	M4 × 7L	45	1.5	13	21	2.9 (3.4)
02A□AHB01-E (02A□AHB0C-E)	1/11	(181.5)	(154.5)																		3.0 (3.5)
02A□AHC01-E (02A□AHC0C-E)	1/21	162	131	107	31	12	12	70	96	100 ⁰ _{-0.035}	105	120	9	29	28 ^{+0.021} ₀	M5 × 8L	55	1.5	13	21	4.1 (4.6)
02A□AH701-E (02A□AH70C-E)	1/33	(193.5)	(162.5)																		
04A□AH101-E (04A□AH10C-E)	1/5	160	133	109	27	10	10	60	83	85 ⁰ _{-0.035}	90	105	9	26	24 ^{+0.021} ₀	M4 × 7L	45	1.5	13	21	3.2 (3.7)
04A□AHB01-E (04A□AHB0C-E)	1/11	172	141	117	31	12	12	70	96	100 ⁰ _{-0.035}	105	120	9	29	28 ^{+0.021} ₀	M5 × 8L	55	1.5	13	21	4.4 (4.9)
04A□AHC01-E (04A□AHC0C-E)	1/21	184	149	125	35	14	13	90	112	115 ⁰ _{-0.035}	120	135	11	33	32 ^{+0.025} ₀	M5 × 8L	70	1.5	13	21	5.8 (6.3)
04A□AH701-E (04A□AH70C-E)	1/33	(215.5)	(180.5)																		

Note: The models and values in parentheses are for servomotors with holding brakes.

Flange-type With Low-backlash Gears External Dimensions Units: mm

(2) 750 W, 1.5 kW

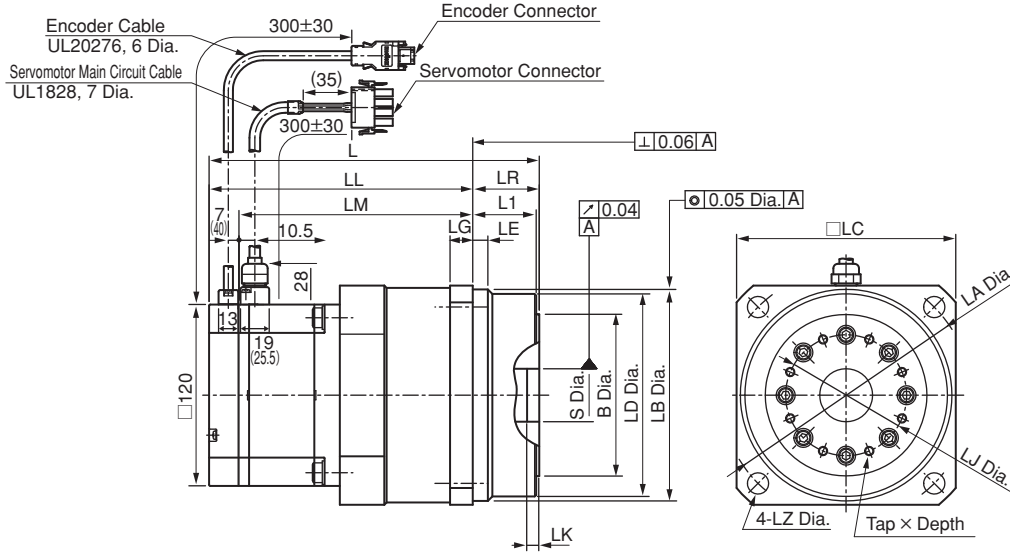

Model SGMPS-	Gear Ratio	L	LL	LM	LR	LE	LG	B	LD	LB	LC	LA	LZ	L1	LJ	LK	S	Tap x Depth	Approx. Mass kg
08A□AH101-E (08A□AH10C-E)	1/5	181.5 (215)	150.5 (184)	131	31	12	12	70	96	100 ⁰ _{-0.035}	105	120	9	29	55	3	28 ^{+0.021} ₀	M5×8L	6.9 (8.4)
08A□AHB01-E (08A□AHB0C-E)	1/11	193.5 (227)	158.5 (192)	139	35	14	13	90	112	115 ⁰ _{-0.035}	120	135	11	33	70	3	32 ^{+0.025} ₀	M5×8L	8.6 (10.1)
08A□AHC01-E (08A□AHC0C-E)	1/21	218.5 (252)	174.5 (208)	155	44	10	15	107	134	140 ⁰ _{-0.040}	145	165	14	42	80	4	35 ^{+0.025} ₀	M6×10L	12.2 (13.7)
08A□AH701-E (08A□AH70C-E)	1/33																		
15A□AH101-E (15A□AH10C-E)	1/5	221.5 (255)	186.5 (220)	167	35	12.5	13	90	112	115 ⁰ _{-0.035}	120	135	11	33	70	3	32 ^{+0.025} ₀	M5×8L	11.6 (13.1)
15A□AHB01-E (15A□AHB0C-E)	1/11	246.5 (280)	202.5 (236)	183	44	10	15	107	134	140 ⁰ _{-0.040}	145	165	14	42	80	4	35 ^{+0.025} ₀	M6×10L	15.8 (17.3)
15A□AHC01-E (15A□AHC0C-E)	1/21	261.5 (295)	208.5 (242)	189	53	16	16	135	163	165 ⁰ _{-0.040}	170	190		51	100	6	47 ^{+0.025} ₀	M8×12L	20.5 (22.0)
15A□AH701-E (15A□AH70C-E)	1/33																		

Note: The models and values in parentheses are for servomotors with holding brakes.

Rotary Servomotors

SGMGV

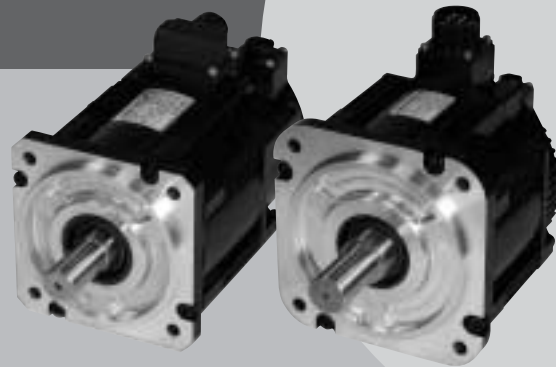

Model Designations

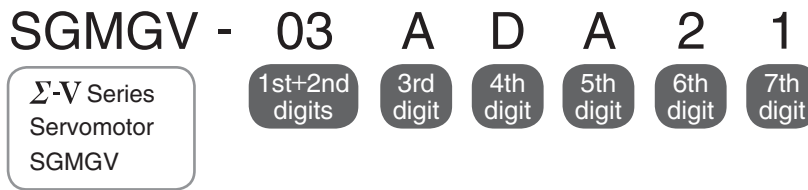

1st+2nd digits Rated Output

Code	Specifications
03	300 W
05	450 W
09	850 W
13	1.3 kW
20	1.8 kW
30	2.9 kW
44	4.4 kW
55	5.5 kW
75	7.5 kW
1A	11 kW
1E	15 kW

3rd digit Power Supply Voltage

Code	Specifications
A	200 VAC
D	400 VAC

4th digit Serial Encoder

Code	Specifications
3	20-bit absolute (standard)
D	20-bit incremental (standard)

5th digit Design Revision Order

Code	Specifications
A	Standard

6th digit Shaft End

Code	Specifications
2	Straight without key (standard)
6	Straight with key and tap (optional)

7th digit Options

Code	Specifications
1	Without options
B	With holding brake (90 VDC)
C	With holding brake (24 VDC)
D	With oil seal and holding brake (90 VDC)
E	With oil seal and holding brake (24 VDC)
S	With oil seal

Features

- High-speed driving of feed shafts for various machines
- Wide selection: 300 W to 15 kW capacity, holding brake option
- Mounted serial encoder: 20 bits, high resolution
- Protective structure: IP67

Application Examples

- Machine tools
- Transfer machines
- Material handling machines
- Food processing equipment

Configurations of connectors for the main circuit vary depending on servomotor capacity.



SGMGV-03/-05

The connectors are used only for Yaskawa servomotors. Order the connectors specified by Yaskawa. Both protective structure IP67 and European Safety Standards compliant connectors are available. For details, refer to page 83 and 84.



SGMGV-09 to -1E

The connectors for these models are round. The connectors specified by Yaskawa are required. Note that the connectors vary depending on the operation environment of servomotors.

Two types of connectors are available.

- Standard connectors:

For details, refer to page 86 and 87.

- Protective structure IP67 and European Safety Standards compliant connectors:

For details, refer to page 88.

Ratings and Specifications

Time Rating: Continuous

Vibration Class: V15

Insulation Resistance: 500 VDC, 10 MΩ min.

Ambient Temperature: 0 to 40°C

Excitation: Permanent magnet

Mounting: Flange-mounted

Thermal Class: F

Withstand Voltage: 1500 VAC for one minute (200-V Class)

1800 VAC for one minute (400-V Class)

Enclosure: Totally enclosed, self-cooled, IP67

(except for shaft opening)

Ambient Humidity: 20% to 80% (no condensation)

Drive Method: Direct drive

Rotation Direction: Counterclockwise (CCW) with forward run reference when viewed from the load side

200-V Class

Servomotor Model: SGMGV-□□□□		03A	05A	09A	13A	20A	30A	44A	55A	75A	1AA	1EA
Rated Output* ¹	kW	0.3	0.45	0.85	1.3	1.8	2.9	4.4	5.5	7.5	11	15
Rated Torque* ¹	N·m	1.96	2.86	5.39	8.34	11.5	18.6	28.4	35.0	48.0	70.0	95.4
Instantaneous Peak Torque* ¹	N·m	5.88	8.92	13.8	23.3	28.7	45.1	71.1	87.6	119	175	224
Rated Current* ¹	Arms	2.8	3.8	6.9	10.7	16.7	23.8	32.8	42.1	54.7	58.6	78
Instantaneous Max. Current* ¹	Arms	8	11	17	28	42	56	84	110	130	140	170
Rated Speed* ¹	min ⁻¹	1500										
Max. Speed* ¹	min ⁻¹	3000									2000	
Torque Constant	N·m/Arms	0.776	0.854	0.859	0.891	0.748	0.848	0.934	0.871	0.957	1.32	1.37
Rotor Moment of Inertia	×10 ⁻⁴ kg·m ²	2.48 (2.73)	3.33 (3.58)	13.9 (16)	19.9 (22)	26 (28.1)	46 (54.5)	67.5 (76.0)	89.0 (97.5)	125 (134)	242 (261)	303 (341)
Rated Power Rate* ¹	kW/s	15.5 (14.1)	24.6 (22.8)	20.9 (18.2)	35.0 (31.6)	50.9 (47.1)	75.2 (63.5)	119 (106)	138 (126)	184 (172)	202 (188)	300 (283)
Rated Angular Acceleration* ¹	rad/s ²	7900 (7180)	8590 (7990)	3880 (3370)	4190 (3790)	4420 (4090)	4040 (3410)	4210 (3740)	3930 (3590)	3840 (3580)	2890 (2680)	3150 (2960)
Applicable SERVOPACK	SGDV-□□□□	3R8A	3R8A	7R6A	120A	180A	330A 220A* ²	330A	470A	550A	590A	780A

*1: These items and torque-motor speed characteristics quoted in combination with a SERVOPACK are at an armature winding temperature of 20°C.

*2: Some restrictions apply when using an SGDV-200A SERVOPACK in combination with an SGMGV-30A servomotor.

Notes: 1 The values in parentheses are for servomotors with holding brakes.

2 The above specifications show the values under the cooling condition when the following heat sinks are mounted on the servomotors.

SGMGV-03A/-05A: 250 mm × 250 mm × 6 mm (aluminum)

SGMGV-09A/-13A/-20A: 400 mm × 400 mm × 20 mm (iron)

SGMGV-30A/-44A/-55A/-75A: 550 mm × 550 mm × 30 mm (iron)

SGMGV-1AA/-1EA: 650 mm × 650 mm × 35 mm (iron)

400-V Class

Servomotor Model: SGMGV-□□□□		03D	05D	09D	13D	20D	30D	44D	55D	75D	1AD	1ED
Rated Output*	kW	0.3	0.45	0.85	1.3	1.8	2.9	4.4	5.5	7.5	11	15
Rated Torque*	N·m	1.96	2.86	5.39	8.34	11.5	18.6	28.4	35.0	48.0	70.0	95.4
Instantaneous Peak Torque*	N·m	5.88	8.92	13.8	23.3	28.7	45.1	71.1	87.6	119	175	224
Rated Current*	Arms	1.4	1.9	3.5	5.4	8.4	11.9	16.5	20.8	25.7	28.1	37.2
Instantaneous Max. Current*	Arms	4	5.5	8.5	14	20	28	40.5	52	65	70	85
Rated Speed*	min ⁻¹	1500										
Max. Speed*	min ⁻¹	3000									2000	
Torque Constant	N·m/Arms	1.55	1.71	1.72	1.78	1.50	1.70	1.93	1.80	1.92	2.64	2.74
Rotor Moment of Inertia	×10 ⁻⁴ kg·m ²	2.48 (2.73)	3.33 (3.58)	13.9 (16)	19.9 (22)	26 (28.1)	46 (54.5)	67.5 (76.0)	89.0 (97.5)	125 (134)	242 (261)	303 (341)
Rated Power Rate*	kW/s	15.5 (14.1)	24.6 (22.8)	20.9 (18.2)	35.0 (31.6)	50.9 (47.1)	75.2 (63.5)	119 (106)	138 (126)	184 (172)	202 (188)	300 (283)
Rated Angular Acceleration*	rad/s ²	7900 (7180)	8590 (7990)	3880 (3370)	4190 (3790)	4420 (4090)	4040 (3410)	4210 (3740)	3930 (3590)	3840 (3580)	2890 (2680)	3150 (2960)
Applicable SERVOPACK	SGDV-□□□□	1R9D	1R9D	3R5D	5R4D	8R4D	120D	170D	210D	260D	280D	370D

*: These items and torque-motor speed characteristics quoted in combination with a SERVOPACK are at an armature winding temperature of 20°C.

Notes: 1 The values in parentheses are for servomotors with holding brakes.

2 The above specifications show the values under the cooling condition when the following heat sinks are mounted on the servomotors.

SGMGV-03D/-05D: 250 mm × 250 mm × 6 mm (aluminum)

SGMGV-09D/-13D/-20D: 400 mm × 400 mm × 20 mm (iron)

SGMGV-30D/-44D/-55D/-75D: 550 mm × 550 mm × 30 mm (iron)

SGMGV-1AD/-1ED: 650 mm × 650 mm × 35 mm (iron)

Ratings and Specifications

● Torque-Motor Speed Characteristics (200 V/400 V) A : Continuous Duty Zone B : Intermittent Duty Zone ^{Note1}

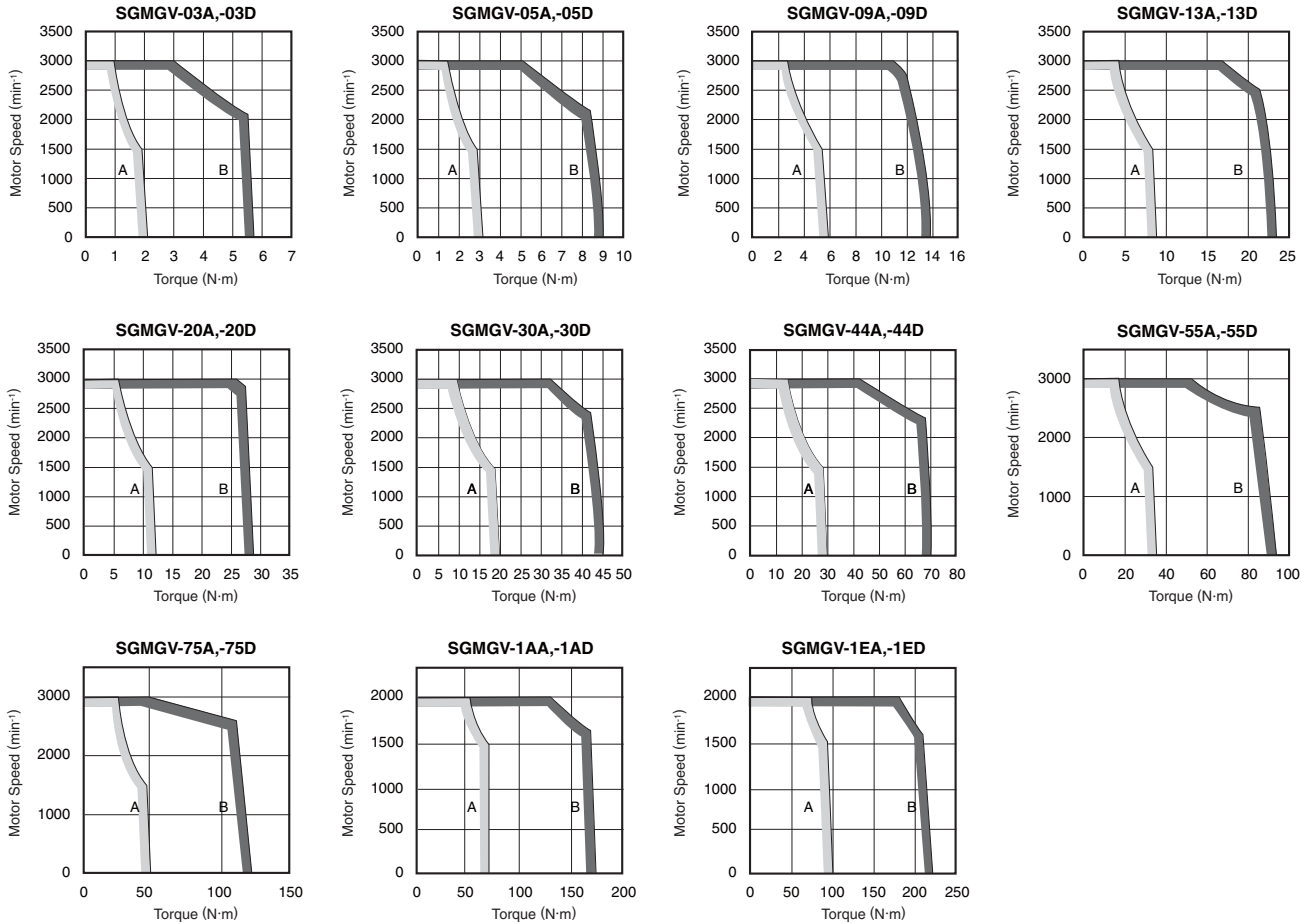

Notes: 1 When the effective torque during intermittent duty is within the rated torque, the servomotor can be used within the intermittent duty zone.
2 When the main circuit cable length exceeds 20 m, note that the intermittent duty zone of the *Torque-Motor Speed Characteristics* will shrink as the line-to-line voltage drops.

● Holding Brake Electrical Specifications

Servomotor Model	Servomotor Rated Output kW	Holding Brake Specifications				
		Holding Torque N·m	Rated Voltage 24 VDC		Rated Voltage 90 VDC	
			Capacity W	Rated Current A (at 20°C)	Capacity W	Rated Current A (at 20°C)
SGMGV-03	0.3	4.5	10	0.42	10	0.11
SGMGV-05	0.45	4.5	10	0.42	10	0.11
SGMGV-09	0.85	12.7	10	0.41	10	0.11
SGMGV-13	1.3	19.6	10	0.41	10	0.11
SGMGV-20	1.8	19.6	10	0.41	10	0.11
SGMGV-30	2.9	43.1	18.5	0.77	18.5	0.21
SGMGV-44	4.4	43.1	18.5	0.77	18.5	0.21
SGMGV-55	5.5	72.6	25	1.05	25	0.28
SGMGV-75	7.5	72.6	25	1.05	25	0.28
SGMGV-1A	11	84.3	32	1.33	32	0.36
SGMGV-1E	15	114.6	35	1.46	35	0.39

Notes: 1 The holding brake is only used to hold the load and cannot be used to stop the servomotor.
2 The holding brake open time and holding brake operation time vary depending on which discharge circuit is used. Make sure holding brake open time and holding brake operation time are correct for your servomotor.
3 A 24-VDC power supply is provided by customers.
4 Refer to page 359 for information on the 90-VDC power supply.

Ratings and Specifications

● Allowable Load Moment of Inertia at the Motor Shaft

The rotor moment of inertia ratio is the value for a servomotor without a gear and a holding brake.

Servomotor Model	Servomotor Rated Output	Allowable Load Moment of Inertia (Rotor Moment of Inertia Ratio)
SGMGV-03 to -1E	0.3 to 1.5 kW	5 times

● Load Moment of Inertia

The larger the load moment of inertia, the worse the movement response of the load.

The allowable load moment of inertia (J_L) depends on the motor capacity, as shown above. This value is provided strictly as a guideline and results may vary depending on servomotor drive conditions.

Use the AC servo drive capacity selection program SigmaJunmaSize+ to check the operation conditions. The program can be downloaded for free from our web site (<http://www.e-mechatronics.com/>).

An overvoltage alarm (A.400) is likely to occur during deceleration if the load moment of inertia exceeds the allowable load moment of inertia. SERVOPACKs with a built-in regenerative resistor may generate a regenerative overload alarm (A.320). Take one of the following steps if this occurs.

- Reduce the torque limit.
- Reduce the deceleration rate.
- Reduce the maximum speed.
- Install an external regenerative resistor if the alarm cannot be cleared using the steps above. Refer to *Regenerative Resistors* on page 360.

● Allowable Radial and Thrust Loads

Design the mechanical system so thrust and radial loads applied to the servomotor shaft end during operation fall within the ranges shown in the table.

Servomotor Model	Allowable Radial Load (F_r) N	Allowable Thrust Load (F_s) N	LR mm	Reference Diagram	
SGMGV-	03□□A21	490	98	37	
	05□□A21	490	98	40	
	09□□A21	490	98	58	
	13□□A21	686	343	58	
	20□□A21	980	392	58	
	30□□A21	1470	490	79	
	44□□A21	1470	490	79	
	55□□A21	1764	588	113	
	75□□A21	1764	588	113	
	1A□□A21	1764	588	116	
	1E□□A21	4998	2156	116	

External Dimensions Units: mm

● Without Holding Brakes

(1) 300 W, 450 W

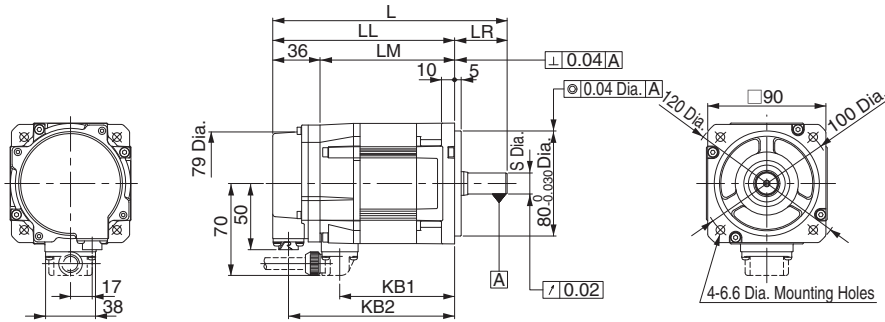

Note: For the specifications of the other shaft ends, refer to page 82.

Model SGMGV-	L	LL	LM	LR	KB1	KB2	Shaft End Dimensions		Approx. Mass kg
							S	Q	
03□□A21	163	126	90	37	75	114	14 ⁰ _{0.011}	25	2.6
05□□A21	179	139	103	40	88	127	16 ⁰ _{0.011}	30	3.2

Note: Models with oil seals are of the same configuration.

• Cable Specifications for Encoder-end Connector (20-bit Encoder)

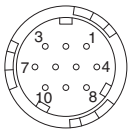

Receptacle: CM10-R10P-D
Applicable plug (To be provided by the customer)
Plug: CM10-AP10S-□-D (Angle)
CM10-SP10S-□-D (Straight)
(Boxes (□) indicate a value that varies, depending on cable size.)
Manufacturer: DDK Ltd.

• Cable Specifications for Servomotor-end Connector

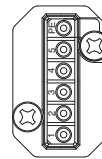

PE	FG (Frame ground)
5	—
4	—
3	Phase U
2	Phase V
1	Phase W

With an Absolute Encoder

1	PS	6	BAT (+)
2	/PS	7	—
3	—	8	—
4	PG 5V	9	PG 0V
5	BAT (-)	10	FG (Frame ground)

With an Incremental Encoder

1	PS	6	—
2	/PS	7	—
3	—	8	—
4	PG 5V	9	PG 0V
5	—	10	FG (Frame ground)

Manufacturer: Japan Aviation Electronics Industry, Ltd.

External Dimensions Units: mm

(2) 850 W to 7.5 kW

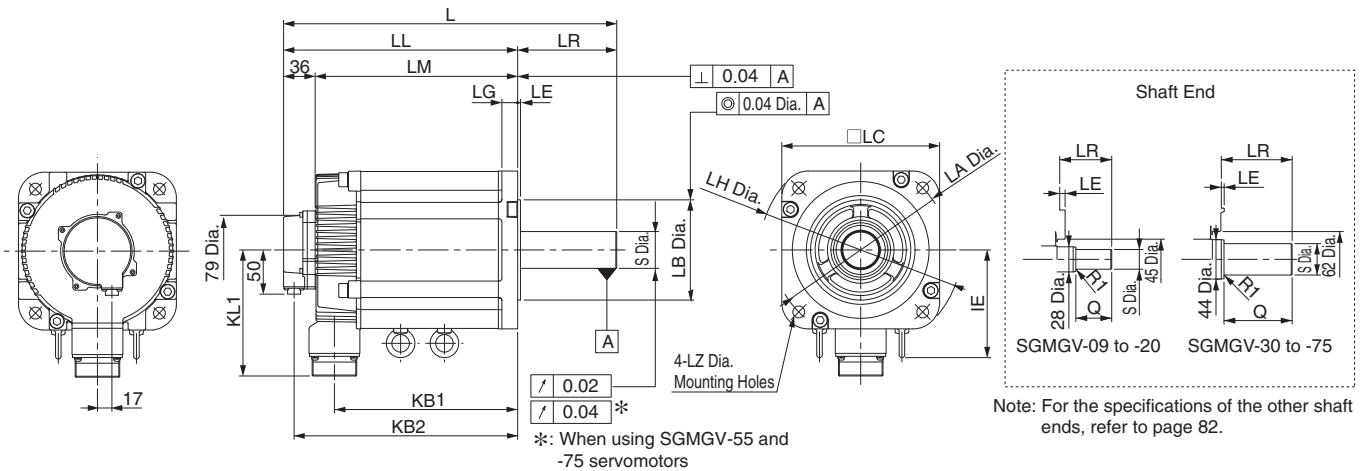

Model SGMGV-	L	LL	LM	LR	KB1	KB2	IE	KL1	Flange Face Dimensions						Shaft End Dimensions		Approx. Mass kg	
									LA	LB	LC	LE	LG	LH	LZ	S		Q
09□□A21	195	137	101	58	83	125	-	104	145	110 ⁰ _{-0.035}	130	6	12	165	9	19 ⁰ _{-0.013}	40	5.5
13□□A21	211	153	117	58	99	141	-	104	145	110 ⁰ _{-0.035}	130	6	12	165	9	22 ⁰ _{-0.013}	40	7.1
20□□A21	229	171	135	58	117	159	-	104	145	110 ⁰ _{-0.035}	130	6	12	165	9	24 ⁰ _{-0.013}	40	8.6
30□□A21	239	160	124	79	108	148	-	134	200	114.3 ⁰ _{-0.025}	180	3.2	18	230	13.5	35 ^{+0.01} ₀	76	13.5
44□□A21	263	184	148	79	132	172	-	134	200	114.3 ⁰ _{-0.025}	180	3.2	18	230	13.5	35 ^{+0.01} ₀	76	17.5
55□□A21	334	221	185	113	163	209	123	144	200	114.3 ⁰ _{-0.025}	180	3.2	18	230	13.5	42 ⁰ _{-0.016}	110	21.5
75□□A21	380	267	231	113	209	255	123	144	200	114.3 ⁰ _{-0.025}	180	3.2	18	230	13.5	42 ⁰ _{-0.016}	110	29.5

Note: Models with oil seals are of the same configuration.

• Cable Specifications for Encoder-end Connector (20-bit Encoder)

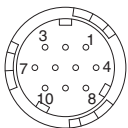

Receptacle: CM10-R10P-D
 Applicable plug (To be provided by the customer)
 Plug: CM10-AP10S-□-D (Angle)
 CM10-SP10S-□-D (Straight)
 (Boxes (□) indicate a value that varies, depending on cable size.)
 Manufacturer: DDK Ltd.

• Cable Specifications for Servomotor-end Connector

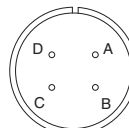

A	Phase U
B	Phase V
C	Phase W
D	FG (Frame ground)

Manufacturer: DDK Ltd.

With an Absolute Encoder

1	PS	6	BAT (+)
2	/PS	7	-
3	-	8	-
4	PG 5V	9	PG 0V
5	BAT (-)	10	FG (Frame ground)

With an Incremental Encoder

1	PS	6	-
2	/PS	7	-
3	-	8	-
4	PG 5V	9	PG 0V
5	-	10	FG (Frame ground)

External Dimensions Units: mm

(3) 11 kW, 15 kW

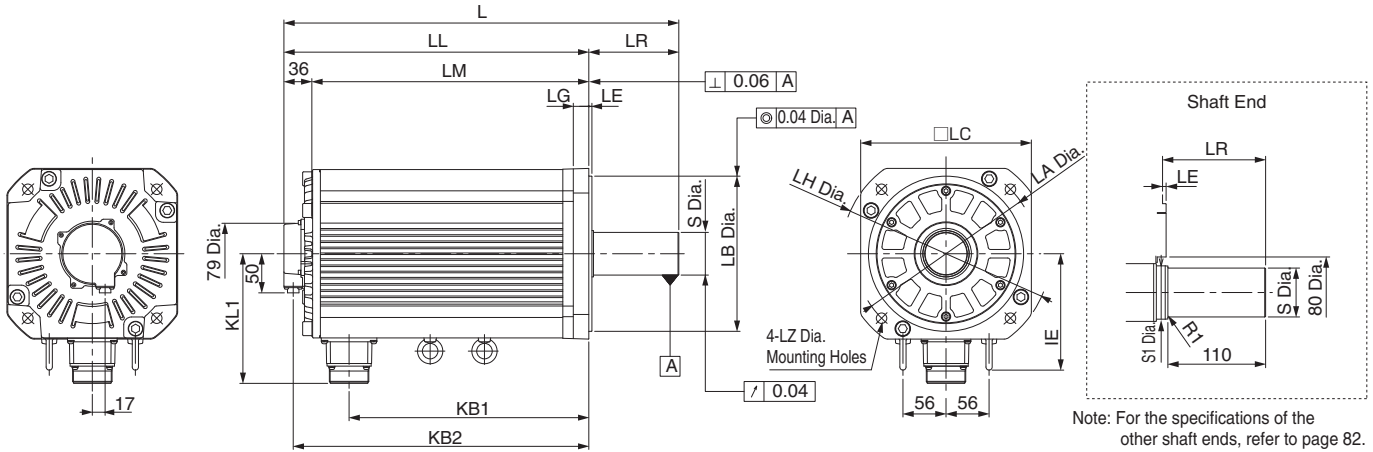

Model SGMGV-	L	LL	LM	LR	KB1	KB2	IE	KL1	Flange Face Dimensions							Shaft End Dimensions		Approx. Mass kg
									LA	LB	LC	LE	LG	LH	LZ	S	S1	
1A □ □ A21	447	331	295	116	247	319	150	168	235	200 ⁰ _{-0.046}	220	4	20	270	13.5	42 ⁰ _{-0.016}	50	57
1E □ □ A21	509	393	357	116	309	381	150	168	235	200 ⁰ _{-0.046}	220	4	20	270	13.5	55 ^{+0.030} _{-0.011}	60	67

Note: Models with oil seals are of the same configuration.

• Cable Specifications for Encoder-end Connector
(20-bit Encoder)

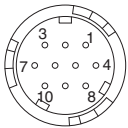

Receptacle: CM10-R10P-D
Applicable plug (To be provided by the customer)
Plug: CM10-AP10S-□-D (Angle)
CM10-SP10S-□-D (Straight)
(Boxes (□) indicate a value that varies,
depending on cable size.)
Manufacturer: DDK Ltd.

• Cable Specifications for Servomotor-end Connector

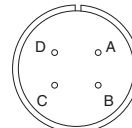

A	Phase U
B	Phase V
C	Phase W
D	FG (Frame ground)

Manufacturer: DDK Ltd.

With an Absolute Encoder

1	PS	6	BAT (+)
2	/PS	7	-
3	-	8	-
4	PG 5V	9	PG 0V
5	BAT (-)	10	FG (Frame ground)

With an Incremental Encoder

1	PS	6	-
2	/PS	7	-
3	-	8	-
4	PG 5V	9	PG 0V
5	-	10	FG (Frame ground)

External Dimensions Units: mm

●With Holding Brakes

(1) 300 W, 450 W

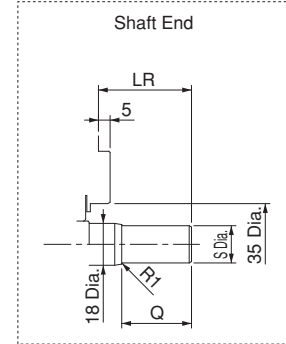
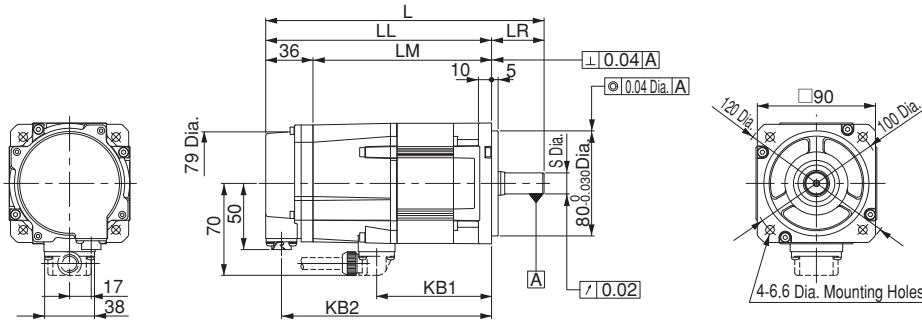

Note: For the specifications of the other shaft ends, refer to page 82.

Model SGMGV-	L	LL	LM	LR	KB1	KB2	Shaft End Dimensions		Approx. Mass kg
							S	Q	
03□□A2□	196	159	123	37	75	147	14 ⁰ _{0.011}	25	3.6
05□□A2□	212	172	136	40	88	160	16 ⁰ _{0.011}	30	4.2

Note: Models with oil seals are of the same configuration.

· Cable Specifications for Encoder-end Connector (20-bit Encoder)

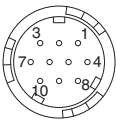

Receptacle: CM10-R10P-D
 Applicable plug (To be provided by the customer)
 Plug: CM10-AP10S-□-D (Angle)
 CM10-SP10S-□-D (Straight)
 (Boxes (□) indicate a value that varies, depending on cable size.)
 Manufacturer: DDK Ltd.

· Cable Specifications for Servomotor-end Connector

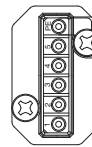

PE	FG (Frame ground)
5	Brake terminal
4	Brake terminal
3	Phase U
2	Phase V
1	Phase W

With an Absolute Encoder

1	PS	6	BAT (+)
2	/PS	7	-
3	-	8	-
4	PG 5V	9	PG 0V
5	BAT (-)	10	FG (Frame ground)

With an Incremental Encoder

1	PS	6	-
2	/PS	7	-
3	-	8	-
4	PG 5V	9	PG 0V
5	-	10	FG (Frame ground)

Manufacturer: Japan Aviation Electronics Industry, Ltd.

External Dimensions Units: mm

(2) 850 W to 7.5 kW

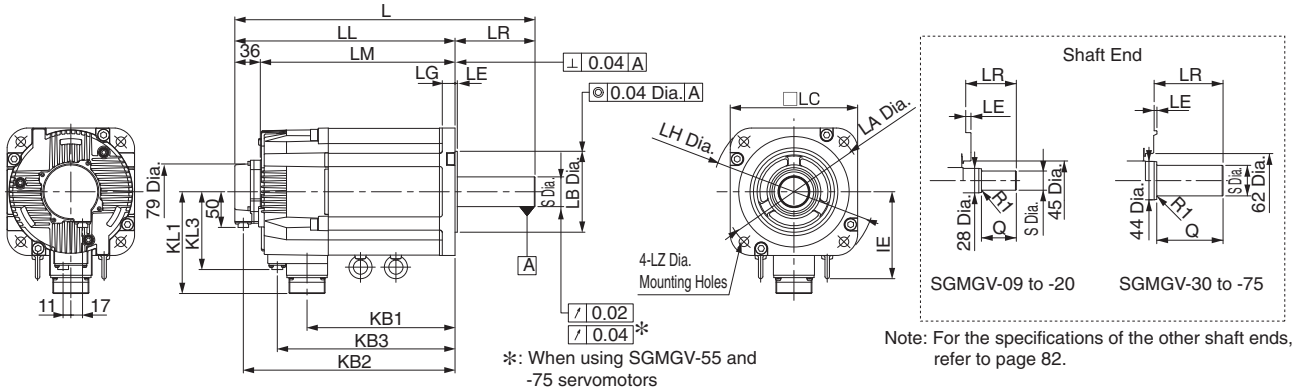

Model SGMGV-	L	LL	LM	LR	KB1	KB2	KB3	IE	KL1	KL3	Flange Face Dimensions							Shaft End Dimensions		Approx. Mass kg
											LA	LB	LC	LE	LG	LH	LZ	S	Q	
09□□A2□	231	173	137	58	83	161	115	-	104	80	145	110 ⁰ _{-0.035}	130	6	12	165	9	19 ⁰ _{-0.013}	40	7.5
13□□A2□	247	189	153	58	99	177	131	-	104	80	145	110 ⁰ _{-0.035}	130	6	12	165	9	22 ⁰ _{-0.013}	40	9.0
20□□A2□	265	207	171	58	117	195	149	-	104	80	145	110 ⁰ _{-0.035}	130	6	12	165	9	24 ⁰ _{-0.013}	40	11.0
30□□A2□	287	208	172	79	108	196	148	-	134	110	200	114.3 ⁰ _{-0.025}	180	3.2	18	230	13.5	35 ⁰ _{-0.01}	76	19.5
44□□A2□	311	232	196	79	132	220	172	-	134	110	200	114.3 ⁰ _{-0.025}	180	3.2	18	230	13.5	35 ⁰ _{-0.01}	76	23.5
55□□A2□	378	265	229	113	163	253	205	123	144	110	200	114.3 ⁰ _{-0.025}	180	3.2	18	230	13.5	42 ⁰ _{-0.016}	110	27.5
75□□A2□	424	311	275	113	209	299	251	123	144	110	200	114.3 ⁰ _{-0.025}	180	3.2	18	230	13.5	42 ⁰ _{-0.016}	110	35

Note: Models with oil seals are of the same configuration.

• Cable Specifications for Encoder-end Connector (20-bit Encoder)

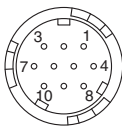

Receptacle: CM10-R10P-D
Applicable plug (To be provided by the customer)
Plug: CM10-AP10S-□-D (Angle)
CM10-SP10S-□-D (Straight)
(Boxes (□) indicate a value that varies, depending on cable size.)
Manufacturer: DDK Ltd.

• Cable Specifications for Servomotor-end Connector

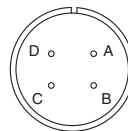

A	Phase U
B	Phase V
C	Phase W
D	FG (Frame ground)

Manufacturer: DDK Ltd.

With an Absolute Encoder

1	PS	6	BAT (+)
2	/PS	7	-
3	-	8	-
4	PG 5V	9	PG 0V
5	BAT (-)	10	FG (Frame ground)

With an Incremental Encoder

1	PS	6	-
2	/PS	7	-
3	-	8	-
4	PG 5V	9	PG 0V
5	-	10	FG (Frame ground)

• Cable Specifications for Brake-end Connector

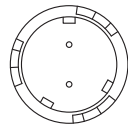

Receptacle: CM10-R2P-D
Applicable plug (To be provided by the customer)
Plug: CM10-AP2S-□-D (Angle)
CM10-SP2S-□-D (Straight)
(Boxes (□) indicate a value that varies, depending on cable size.)
Manufacturer: DDK Ltd.

Brake terminal
Brake terminal

Note: No polarity for connection to the brake terminals

External Dimensions Units: mm

(3) 11 kW, 15 kW

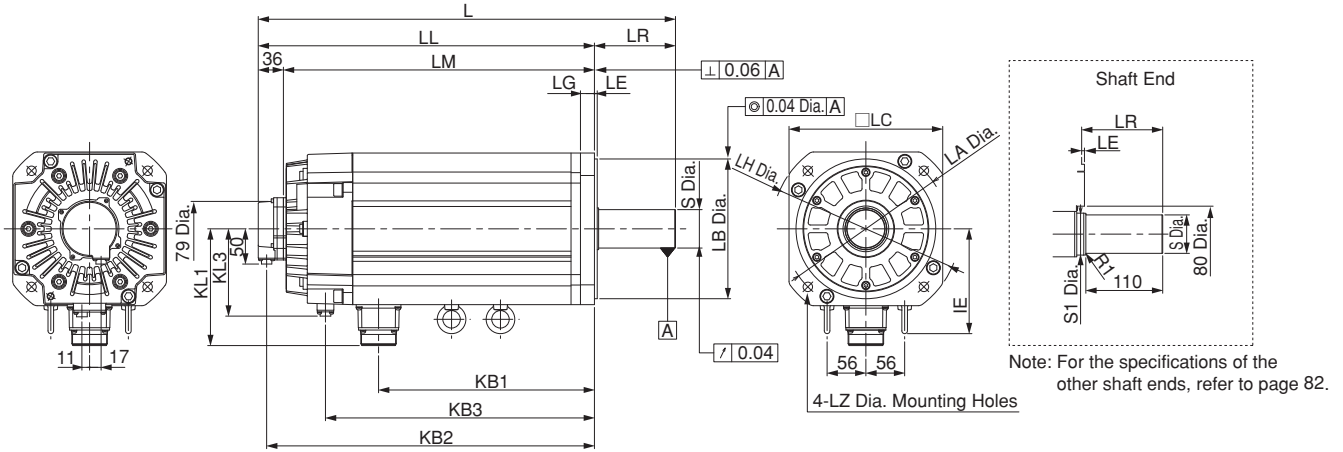

Model SGMGV-	L	LL	LM	LR	KB1	KB2	KB3	IE	KL1	KL3	Flange Face Dimensions						Shaft End Dimensions		Approx. Mass kg	
											LA	LB	LC	LE	LG	LH	LZ	S		S1
1A□□A2□	498	382	346	116	247	370	315	150	168	125	235	200 ⁰ _{0.046}	220	4	20	270	13.5	42 ⁰ _{0.016}	50	65
1E□□A2□	598	482	446	116	309	470	385	150	168	125	235	200 ⁰ _{0.046}	220	4	20	270	13.5	55 ^{+0.030} _{+0.011}	60	85

Note: Models with oil seals are of the same configuration.

• Cable Specifications for Encoder-end Connector
(20-bit Encoder)

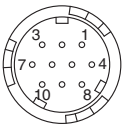

Receptacle: CM10-R10P-D
Applicable plug (To be provided by the customer)
Plug: CM10-AP10S-□-D (Angle)
CM10-SP10S-□-D (Straight)
(Boxes □ indicate a value that varies,
depending on cable size.)
Manufacturer: DDK Ltd.

• Cable Specifications for Servomotor-end Connector

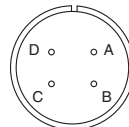

A	Phase U
B	Phase V
C	Phase W
D	FG (Frame ground)

Manufacturer: DDK Ltd.

With an Absolute Encoder

1	PS	6	BAT (+)
2	/PS	7	-
3	-	8	-
4	PG 5V	9	PG 0V
5	BAT (-)	10	FG (Frame ground)

With an Incremental Encoder

1	PS	6	-
2	/PS	7	-
3	-	8	-
4	PG 5V	9	PG 0V
5	-	10	FG (Frame ground)

• Cable Specifications for Brake-end Connector

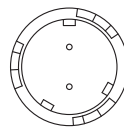

Receptacle: CM10-R2P-D
Applicable plug (To be provided by the customer)
Plug: CM10-AP2S-□-D (Angle)
CM10-SP2S-□-D (Straight)
(Boxes □ indicate a value that varies,
depending on cable size.)
Manufacturer: DDK Ltd.

Brake terminal
Brake terminal

Note: No polarity for connection to the brake terminals

External Dimensions Units: mm

● Shaft End

SGMGV -

Code	Specifications	Remarks
2	Straight without key	Standard
6	Straight with key and tap for one location (Key slot is JIS B1301-1996 fastening type)	Optional

Shaft End	Model SGMGV-									
	03	05	09	13	20	30/44	55/75	1A	1E	
Code: 2 (Straight without Key)										
	LR	37	40	58	58	58	79	113	116	116
	Q	25	30	40	40	40	76	110	110	110
	S	14 ⁰ _{-0.011}	16 ⁰ _{-0.011}	19 ⁰ _{-0.013}	22 ⁰ _{-0.013}	24 ⁰ _{-0.013}	35 ^{+0.01} ₀	42 ⁰ _{-0.016}	42 ⁰ _{-0.016}	55 ^{+0.030} _{+0.011}
Code: 6 (Straight with Key and Tap)										
	LR	37	40	58	58	58	79	113	116	116
	Q	25	30	40	40	40	76	110	110	110
	QK	15	20	25	25	25	60	90	90	90
	S	14 ⁰ _{-0.011}	16 ⁰ _{-0.011}	19 ⁰ _{-0.013}	22 ⁰ _{-0.013}	24 ⁰ _{-0.013}	35 ^{+0.01} ₀	42 ⁰ _{-0.016}	42 ⁰ _{-0.016}	55 ^{+0.030} _{+0.011}
	W	5	5	5	6	8	10	12	12	16
	T	5	5	5	6	7	8	8	8	10
	U	3	3	3	3.5	4	5	5	5	6
	P	M4 Screw, Depth 10	M5 Screw, Depth 12				M12 Screw, Depth 25	M16 Screw, Depth 32	M20 Screw, Depth 40	

Selecting Cables (SGMGV-03 / -05)

● Cables Connections

- Standard Wiring (Max. encoder cable length: 20 m)

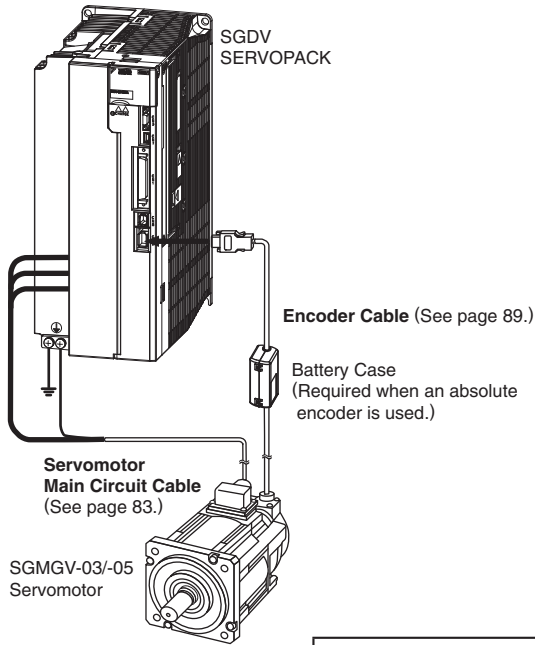

- Encoder Cable Extension from 30 to 50 m
(See page 91.)

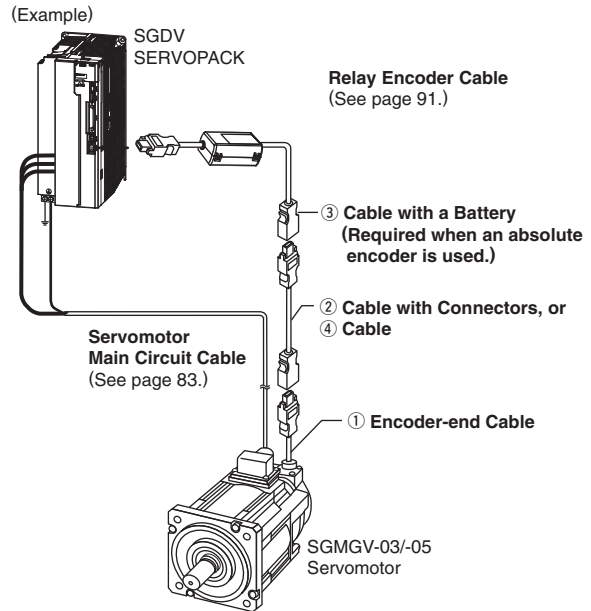

⚠ CAUTION

- Separate the servomotor main circuit cable wiring from the I/O signal cable and encoder cable at least 30 cm, and do not bundle or run them in the same duct.
- When the main circuit cable length exceeds 20 m, note that the intermittent duty zone of the *Torque-Motor Speed Characteristics* will shrink as the line-to-line voltage drops.

● Servomotor Main Circuit Cable

Servomotor Rated Output	Name	Length	Order No.	Specifications	Details
			Standard (Flexible) Type*		
0.3 kW 0.45 kW	For Servomotor without Holding Brakes	3 m	JZSP-CVM21-03-E		(1)
		5 m	JZSP-CVM21-05-E		
		10 m	JZSP-CVM21-10-E		
		15 m	JZSP-CVM21-15-E		
		20 m	JZSP-CVM21-20-E		
		30 m	JZSP-CVM21-30-E		
		40 m	JZSP-CVM21-40-E		
	50 m	JZSP-CVM21-50-E			
	For Servomotor with Holding Brakes	3 m	JZSP-CVM41-03-E		(2)
		5 m	JZSP-CVM41-05-E		
		10 m	JZSP-CVM41-10-E		
		15 m	JZSP-CVM41-15-E		
		20 m	JZSP-CVM41-20-E		
		30 m	JZSP-CVM41-30-E		
40 m		JZSP-CVM41-40-E			
50 m	JZSP-CVM41-50-E				
	Servomotor-end Connector Kit	—	JZSP-CVM9-1-E	Crimping Type (A crimp tool is required.)	(3)

*: These flexible cables are provided as standard equipment.

(Cont'd)

Selecting Cables (SGMGV-03 / -05)

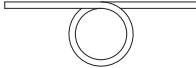
Servomotor Rated Output	Name	Length	Order No.		Specifications	Details
			Standard (Flexible) Type*			
0.3 kW 0.45 kW	Cables	For Servomotor without Holding Brakes (4 wires)	5 m	JZSP-CVM29-05-E		(4)
			10 m	JZSP-CVM29-10-E		
			15 m	JZSP-CVM29-15-E		
			20 m	JZSP-CVM29-20-E		
			30 m	JZSP-CVM29-30-E		
			40 m	JZSP-CVM29-40-E		
			50 m	JZSP-CVM29-50-E		
			For Servomotor with Holding Brakes (6 wires)	5 m		
		10 m		JZSP-CVM49-10-E		
		15 m		JZSP-CVM49-15-E		
		20 m		JZSP-CVM49-20-E		
		30 m		JZSP-CVM49-30-E		
		50 m		JZSP-CVM49-50-E		

*: These flexible cables are provided as standard equipment.

(1) Wiring Specifications for Servomotors without Holding Brakes

SERVOPACK-end Leads		Servomotor-end Connector	
Wire Color	Signal	Signal	Pin No.
Green/yellow	FG	FG	PE
Blue	Phase W	Phase W	1
White	Phase V	Phase V	2
Red	Phase U	Phase U	3
		-	4
		-	5

(2) Wiring Specifications for Servomotor with Holding Brakes

SERVOPACK-end Leads		Servomotor-end Connector	
Wire Color	Signal	Signal	Pin No.
Green/yellow	FG	FG	PE
Blue	Phase W	Phase W	1
White	Phase V	Phase V	2
Red	Phase U	Phase U	3
Black	Brake	Brake	4
Black	Brake	Brake	5

Note: No polarity for connection to a holding brake

(3) Servomotor-end Connector Kit Specifications

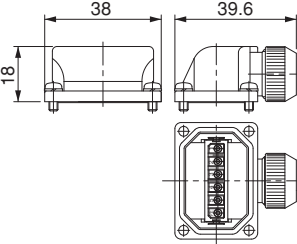
Items	Specifications	External Dimensions mm
Order No.	JZSP-CVM9-1-E (Cables are not included.)	
Applicable Servomotors	SGMGV-03/-05	
Manufacturer	Japan Aviation Electronics Industry, Ltd.	
Plug	JNYFX06SJ3	
Electrical Contact	ST-TMH-S-C1B	
Applicable Wire Size	AWG18 to 22	
Outer Diameter of Insulating Sheath	1.3 dia. to 1.8 dia.	
Crimp Hand tool	CT160-3-TMH5B	
Tool Applicator	350-TMH5B-2B	
Mounting Screw	M3 Pan head screw	
Applicable Cable Outer Diameter	6.9 dia. to 8.3 dia.	

(4) Cable Specifications (Flexible Type)

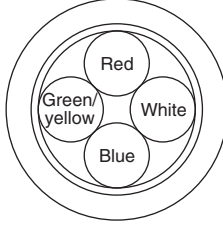
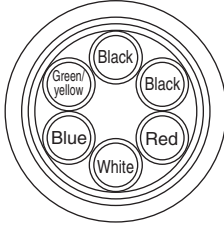
Items	For Servomotor without Holding Brakes (4 wires)	For Servomotor with Holding Brakes (6 wires)
Order No.*	JZSP-CVM29-□□-E	JZSP-CVM49-□□-E
Cable Length	50 m max.	
Specifications	UL2586 (Rating temperature: 105°C) AWG20×4C For power line: AWG20 (0.55 mm ²) Outer diameter of insulating sheath: 1.77 dia.	UL2586 (Rating temperature: 105°C) AWG20×6C For power line: AWG20 (0.55 mm ²) Outer diameter of insulating sheath: 1.77 dia. For holding brake line: AWG20 (0.55 mm ²) Outer diameter of insulating sheath: 1.77 dia.
Finished Dimensions	7.3±0.3 dia.	7.4±0.3 dia.
Internal Configuration and Lead Color		
Yaskawa Standard Specifications (Standard Length)	Cable length: 5 m, 10 m, 15 m, 20 m, 30 m, 40 m, 50 m	

*: Specify the cable length in □□ of order no.
Example: JZSP-CVM29-□□-05-E (5 m)

Selecting Cables (SGMGV-09 to -1E)

● Cables Connections

- Standard Wiring (Max. encoder cable length: 20 m)

- Encoder Cable Extension from 30 to 50 m

(See page 91.)

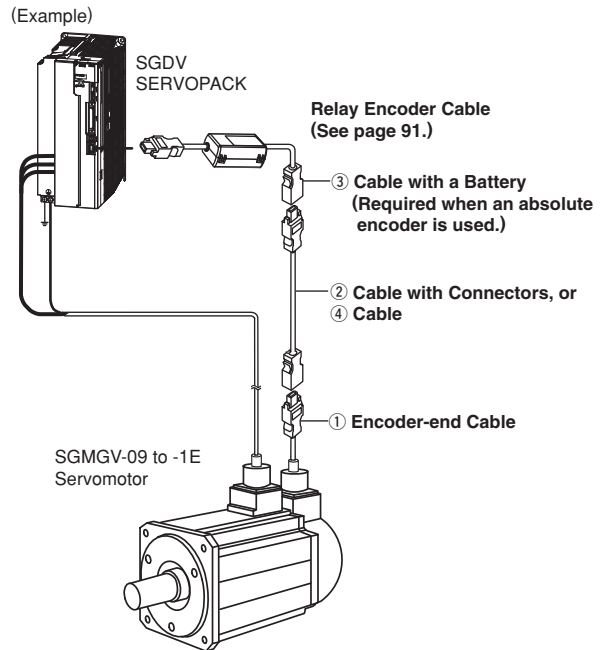
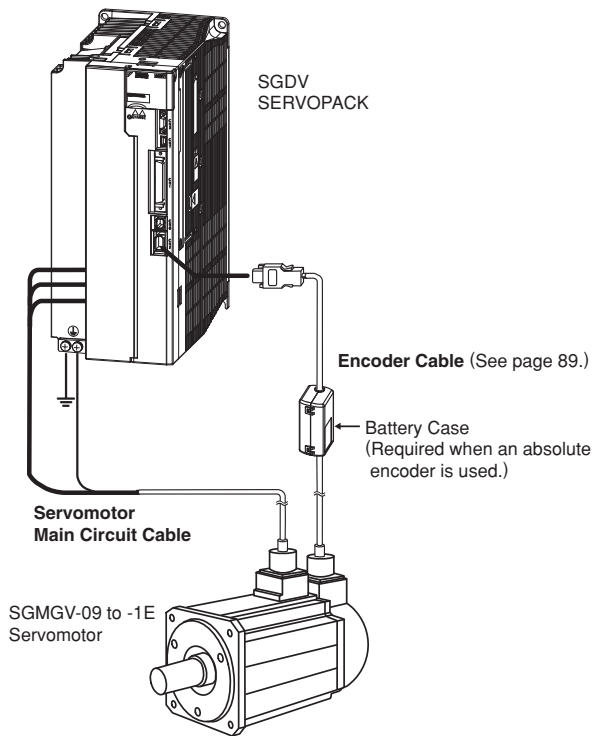

⚠ CAUTION

- Separate the servomotor main circuit cable wiring from the I/O signal cable and encoder cable at least 30 cm, and do not bundle or run them in the same duct.
- When the main circuit cable length exceeds 20 m, note that the intermittent duty zone of the *Torque-Motor Speed Characteristics* will shrink as the line-to-line voltage drops.

● Servomotor Main Circuit Cables

Customers must assemble the servomotor's main circuit cables and attach connectors to connect the SERVOPACKs and the SGMGV servomotors.

The connectors specified by Yaskawa are required. Note that the connectors vary depending on the operation environment of servomotors.

Two types of connectors are available.

- Standard connectors
- Protective structure IP67 and European Safety Standards compliant connectors

Yaskawa does not specify which cables to use. Use appropriate cables for the connectors.

Selecting Cables (SGMGV-09 to -1E)

● Standard Connectors
● Connector Configuration

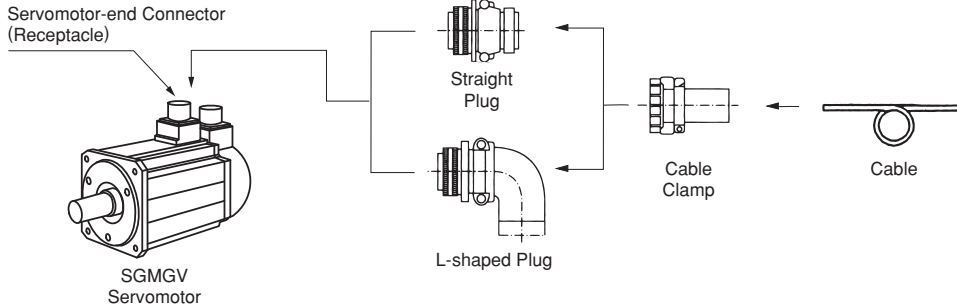

(1) Without Holding Brakes

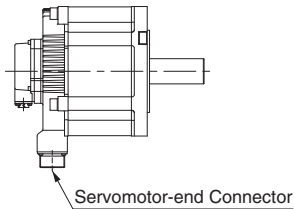

Servomotor-end Connector
For 0.85 to 15 kW

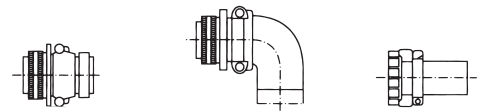

Capacity kW	Servomotor-end Connector (Receptacle)	Cable-end Connector (Not provided by Yaskawa)		
		Straight Plug	L-shaped Plug	Cable Clamp
0.85 1.3 1.8	MS3102A18-10P	MS3106B18-10S	MS3108B18-10S	MS3057-10A
2.9 4.4	MS3102A22-22P	MS3106B22-22S	MS3108B22-22S	MS3057-12A
5.5 to 15	MS3102A32-17P	MS3106B32-17S	MS3108B32-17S	MS3057-20A

Note: Servomotor-end connectors (receptacles) are RoHS-compliant. Contact the respective connector manufacturers for RoHS-compliant cable-end connectors (not provided by Yaskawa).

(2) With Holding Brakes

0.85 to 15 kW servomotors require servomotor-end connector and brake power supply connector. The servomotor-end connector is the same as is used for servomotors without holding brakes.

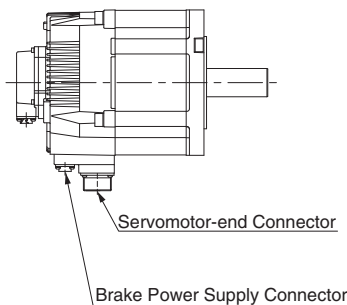

Brake Power Supply Connector
0.85 to 15 kW



Capacity kW	Servomotor-end Connector (Receptacle)	Cable-end Connector (Not provided by Yaskawa)		
		Straight Plug	L-shaped Plug	Manufacturer
0.85 to 15	CM10-R2P-D	CM10-SP2S-S-D Applicable Cable: 4.0 dia. to 6.0 dia.	CM10-AP2S-S-D Applicable Cable: 4.0 dia. to 6.0 dia.	DDK Ltd.
		CM10-SP2S-M-D Applicable Cable: 6.0 dia. to 9.0 dia.	CM10-AP2S-M-D Applicable Cable: 6.0 dia. to 9.0 dia.	
		CM10-SP2S-L-D Applicable Cable: 9.0 dia. to 11.6 dia.	CM10-AP2S-L-D Applicable Cable: 9.0 dia. to 11.6 dia.	

To order a brake power supply connector kit (0.85 to 15 kW) with the order no. below, contact your Yaskawa representative.

J Z S P - C V B 9 - S M S2 - E

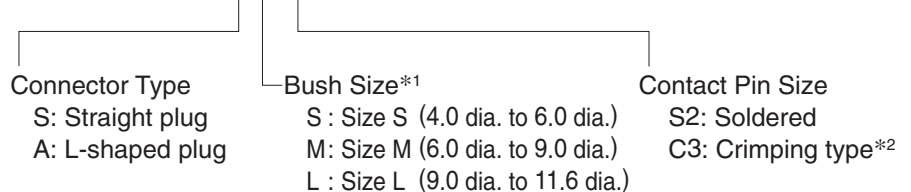

*1: A size-M connector kit is available as a standard equipment.
*2: A crimp tool (model: 357J-50448T) by DDK Ltd. is required.

Selecting Cables (SGMGV-09 to -1E) Units: mm

• Cable-end Connectors

(1) MS3106B□□-□□S :

Straight Plug

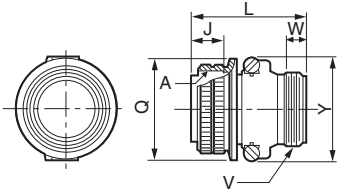

Shell Size	Joint Screw A	Length of Joint Portion J±0.12	Overall Length L max.	Outer Diameter of Joint Nut Q ⁺⁰ _{-0.38}	Cable Clamp Set Screw V	Effective Screw Length W min.	Maximum Width Y max.
18	1-1/8-18UNEF	18.26	52.37	34.13	1-20UNEF	9.53	42
22	1-3/8-18UNEF	18.26	55.57	40.48	1-3/16-18UNEF	9.53	50
32	2-18UNS	18.26	61.92	56.33	1-3/4-18UNS	11.13	66

(2) MS3108B□□-□□S :

L-shaped Plug

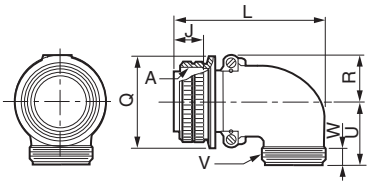

Shell Size	Joint Screw A	Length of Joint Portion J±0.12	Overall Length L max.	Outer Diameter of Joint Nut Q ⁺⁰ _{-0.38}	R ±0.5	U ±0.5	Cable Clamp Set Screw V	Effective Screw Length W min.
18	1-1/8-18UNEF	18.26	68.27	34.13	20.5	30.2	1-20UNEF	9.53
22	1-3/8-18UNEF	18.26	76.98	40.48	24.1	33.3	1-3/16-18UNEF	9.53
32	2-18UNS	18.26	95.25	56.33	32.8	44.4	1-3/4-18UNS	11.13

(3) MS3057-□□A : Cable Clamp with Rubber Bushing

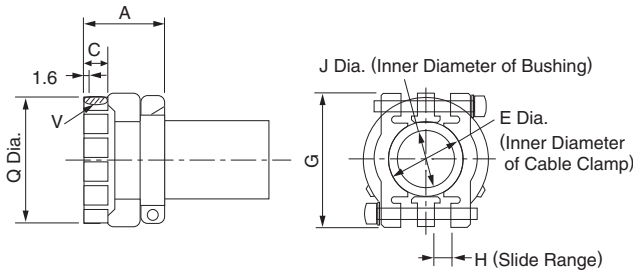

Cable Clamp Type	Applicable Connector Shell Size	Overall Length A±0.7	Effective Screw Length C	E Diameter G±0.7	H	J Diameter	Set Screw V	Outer Diameter Q±0.7 Dia.	Attached Bushing
MS3057-10A	18	23.8	10.3	15.9	31.7	3.2	14.3	1-20UNEF	AN3420-10
MS3057-12A	20, 22	23.8	10.3	19	37.3	4	15.9	1-3/16-18UNEF	AN3420-12
MS3057-20A	32	27.8	11.9	31.7	51.6	6.3	23.8	1-3/4-18UNS	AN3420-20

• Dimensional Drawings of Brake Power Supply

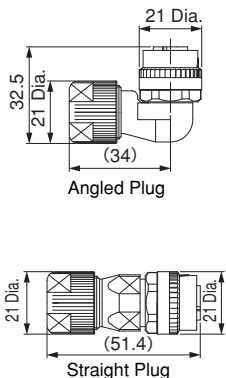

Items	Specifications
Connector Order No.	CM10-□P2S-□-D (Cables are not included.)
Protective Structure	IP67
Manufacturer	DDK Ltd.
Instructions	Angled plug (CM10-AP2S-□-D): TC-573, Straight plug (CM10-SP2S-□-D): TC-583
Electrical Contact Order No.	<p>Electrical contact (100 pcs in one bag)</p> <ul style="list-style-type: none"> ·Crimping type: CM10-#22SC(C3)-100, Wire size: AWG16 to 20, Outer diameter of sheath: 1.87 to 2.45 dia., Hand tool: 357J-50448T ·Soldered type: CM10-#22SC (S2)-100, Wire size: AWG16 max. <p>Real contact (4000 pcs on one reel)</p> <ul style="list-style-type: none"> ·Crimping type: CM10-#22SC(C3)-4000, Wire size: AWG 16 to 20, Outer diameter of sheath: 1.87 to 2.45 dia., Semi-automatic tool: AP-A50541T (product name for one set), AP-A50541T-1 (product name for applicator) <p>Note: The product name of the semi-automatic tool refers to the product name of the press and applicator (crimper) as a set.</p>

Selecting Cables (SGMGV-09 to -1E)

● **Protective Structure IP67 and European Safety Standards Compliant Connector**

● **Connector Configuration**

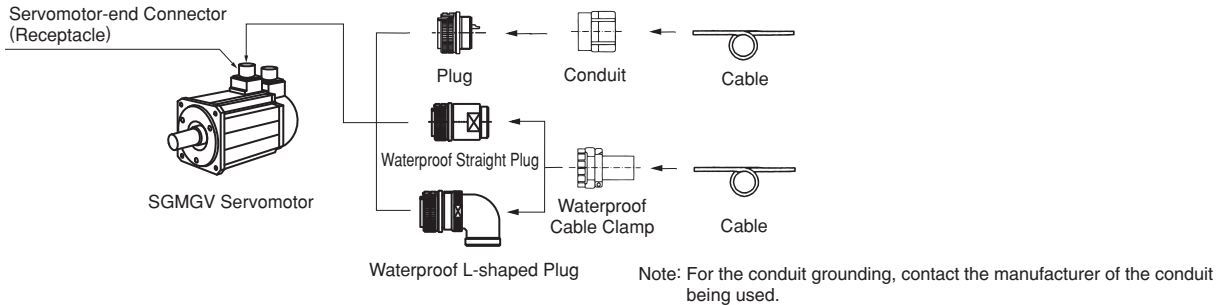

(1) Without Holding Brakes

Servomotor-end Connector
For 0.85 to 15 kW

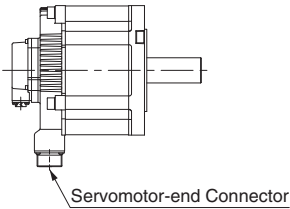

Capacity kW	Servomotor-end Connector (Receptacle)	Cable-end Connector (Not Provided by Yaskawa)			Applicable Cable Diameter (For Reference)	Manufacturer
		Straight Plug	L-shaped Plug	Cable Clamp		
0.85 1.3 1.8	CE05-2A18-10PD-D	CE05-6A18-10SD-D-BSS	CE05-8A18-10SD-D-BAS	CE3057-10A-1-D	10.5 dia. to 14.1 dia.	DDK Ltd.
				CE3057-10A-2-D	8.5 dia. to 11.0 dia.	
				CE3057-10A-3-D	6.5 dia. to 8.7 dia.	
2.9 4.4	CE05-2A22-22PD-D	CE05-6A22-22SD-D-BSS	CE05-8A22-22SD-D-BAS	CE3057-12A-1-D	12.5 dia. to 16.0 dia.	
				CE3057-12A-2-D	9.5 dia. to 13.0 dia.	
				CE3057-12A-3-D	6.8 dia. to 10.0 dia.	
				CE3057-12A-7-D	14.5 dia. to 17.0 dia.	
5.5 to 15	CE05-2A32-17PD-D	CE05-6A32-17SD-D-BSS	CE05-8A32-17SD-D-BAS	CE3057-20A-1-D	22 dia. to 23.8 dia.	
				CE3057-20A-2-D	24 dia. to 26.6 dia.	
				CE3057-20A-3-D	22 dia. to 22.5 dia.	

(2) With Holding Brakes

0.85 to 15 kW servomotors require servomotor-end connector and brake power supply connector.
The servomotor-end connector is the same as is used for servomotors without holding brakes.

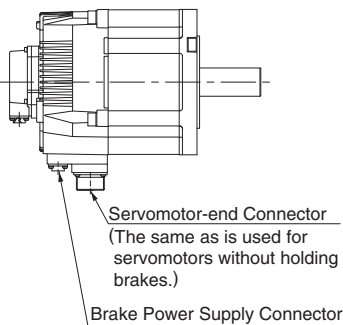

Brake Power Supply Connector
0.85 to 15 kW

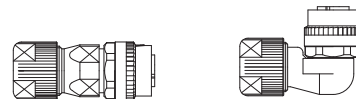

Capacity kW	Servomotor-end Connector (Receptacle)	Cable-end Connector (Not provided by Yaskawa)		Manufacturer
		Straight Plug	L-shaped Plug	
0.85 to 15	CM10-R2P-D	CM10-SP2S-S-D Applicable Cable: 4.0 dia. to 6.0 dia.	CM10-AP2S-S-D Applicable Cable: 4.0 dia. to 6.0 dia.	DDK Ltd.
		CM10-SP2S-M-D Applicable Cable: 6.0 dia. to 9.0 dia.	CM10-AP2S-M-D Applicable Cable: 6.0 dia. to 9.0 dia.	
		CM10-SP2S-L-D Applicable Cable: 9.0 dia. to 11.6 dia.	CM10-AP2S-L-D Applicable Cable: 9.0 dia. to 11.6 dia.	

To order a brake power supply connector kit (0.85 to 15 kW) with the order no. below, contact your Yaskawa representative.

J Z S P - C V B 9 - S M S2 - E

Connector Type
S: Straight plug
A: L-shaped plug





Bush Size*1
S: Size S (4.0 dia. to 6.0 dia.)
M: Size M (6.0 dia. to 9.0 dia.)
L: Size L (9.0 dia. to 11.6 dia.)

Contact Pin Size
S2: Soldered
C3: Crimping type*2

*1: A size-M connector kit is available as a standard equipment.
*2: A crimp tool (model: 357J-50448T) by DDK Ltd. is required.

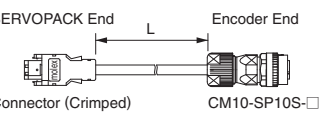
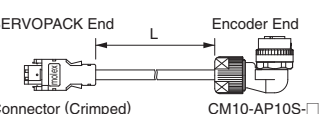
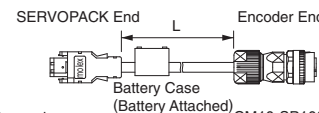
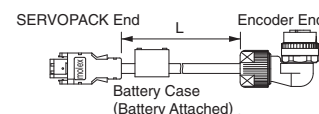
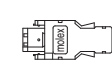
Selecting Cables

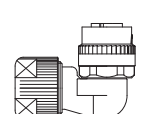
●Encoder Cables (Max. length: 20 m)

Name	Length (L)	Order No.		Specifications	Details
		Standard Type	Flexible Type*1		
Encoder Cable with Connectors (For Incremental Encoder)	3 m	JZSP-CVP01-03-E	JZSP-CVP11-03-E	 <p>SERVOPACK End Encoder End</p> <p>Connector (Crimped) (Molex Japan Co., Ltd.) CM10-SP10S-□-D (DDK Ltd.)</p>	(1)
	5 m	JZSP-CVP01-05-E	JZSP-CVP11-05-E		
	10 m	JZSP-CVP01-10-E	JZSP-CVP11-10-E		
	15 m	JZSP-CVP01-15-E	JZSP-CVP11-15-E		
	20 m	JZSP-CVP01-20-E	JZSP-CVP11-20-E		
	3 m	JZSP-CVP02-03-E	JZSP-CVP12-03-E	 <p>SERVOPACK End Encoder End</p> <p>Connector (Crimped) (Molex Japan Co., Ltd.) CM10-AP10S-□-D (DDK Ltd.)</p>	
	5 m	JZSP-CVP02-05-E	JZSP-CVP12-05-E		
	10 m	JZSP-CVP02-10-E	JZSP-CVP12-10-E		
	15 m	JZSP-CVP02-15-E	JZSP-CVP12-15-E		
	20 m	JZSP-CVP02-20-E	JZSP-CVP12-20-E		
Encoder Cable with Connectors (For Absolute Encoder, with a Battery Case)	3 m	JZSP-CVP06-03-E	JZSP-CVP26-03-E	 <p>SERVOPACK End Encoder End</p> <p>Connector (Crimped)(Molex Japan Co., Ltd.) CM10-SP10S-□-D (DDK Ltd.)</p>	(2)
	5 m	JZSP-CVP06-05-E	JZSP-CVP26-05-E		
	10 m	JZSP-CVP06-10-E	JZSP-CVP26-10-E		
	15 m	JZSP-CVP06-15-E	JZSP-CVP26-15-E		
	20 m	JZSP-CVP06-20-E	JZSP-CVP26-20-E	 <p>SERVOPACK End Encoder End</p> <p>Connector (Crimped)(Molex Japan Co., Ltd.) CM10-AP10S-□-D (DDK Ltd.)</p>	
	3 m	JZSP-CVP07-03-E	JZSP-CVP27-03-E		
	5 m	JZSP-CVP07-05-E	JZSP-CVP27-05-E		
	10 m	JZSP-CVP07-10-E	JZSP-CVP27-10-E		
SERVOPACK-end Connector Kit		JZSP-CMP9-1-E		<p>Soldered</p>  <p>(Molex Japan Co., Ltd.)</p>	(3)
	Encoder-end Connectors for Protective Structure IP67 Straight Plug	JZSP-CVP9-1-E	<p>Connector Specifications</p> <p>Plug: CM10-SP10S-M-D</p> <p>Electrical Contact: (Crimped)*2</p> <p>CM10-#22SC(C4)-100</p> <p>(Applicable Cable Diameter: 6.0 dia. to 9.0 dia.)</p>		 + Electrical Contact
JZSP-CVP9-3-E		<p>Connector Specifications</p> <p>Plug: CM10-SP10S-M-D</p> <p>Electrical Contact: (Soldered)</p> <p>CM10-#22SC(S1)-100</p> <p>(Applicable Cable Diameter: 6.0 dia. to 9.0 dia.)</p>		(DDK Ltd.)	
Encoder-end Connectors for Protective Structure IP67 L-shaped Plug	JZSP-CVP9-2-E	<p>Connector Specifications</p> <p>Plug: CM10-AP10S-M-D</p> <p>Electrical Contact: (Crimped)*2</p> <p>CM10-#22SC(C4)-100</p> <p>(Applicable Cable Diameter: 6.0 dia. to 9.0 dia.)</p>		 + Electrical Contact	-
	JZSP-CVP9-4-E	<p>Connector Specifications</p> <p>Plug: CM10-AP10S-M-D</p> <p>Electrical Contact: (Soldered)</p> <p>CM10-#22SC(S1)-100</p> <p>(Applicable Cable Diameter: 6.0 dia. to 9.0 dia.)</p>			
Cables	3 m	JZSP-CMP09-03-E	JZSP-CSP39-03-E		(4)
	5 m	JZSP-CMP09-05-E	JZSP-CSP39-05-E		
	10 m	JZSP-CMP09-10-E	JZSP-CSP39-10-E		
	15 m	JZSP-CMP09-15-E	JZSP-CSP39-15-E		
	20 m	JZSP-CMP09-20-E	JZSP-CSP39-20-E		

*1: Use flexible cables for movable sections such as robot arms.

*2: A crimp tool (357J-52667T) is required.

Selecting Cables

(1) Wiring Specifications for Cable with Connectors (For incremental encoder)

• Standard Type

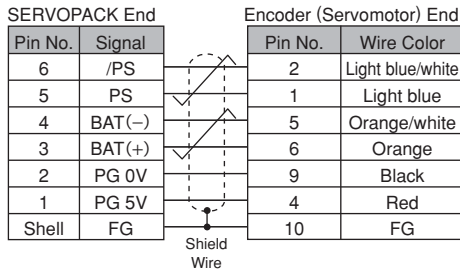

• Flexible Type

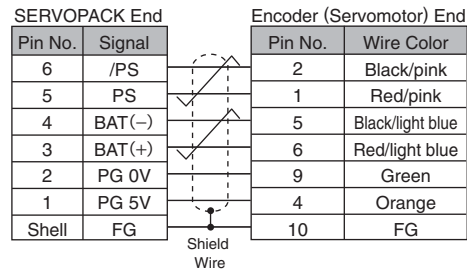

(2) Wiring Specifications for Cable with Connectors (For absolute encoder, with a battery case)

• Standard Type

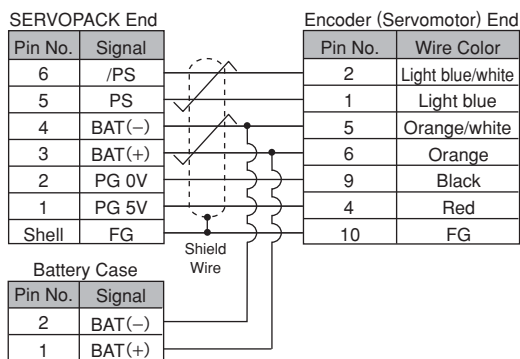

• Flexible Type

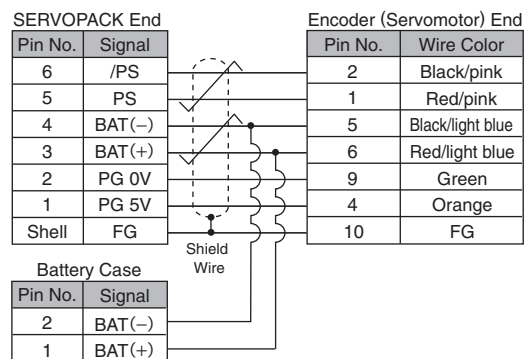

(3) SERVOPACK-end Connector Kit Specifications

Items	Specifications
Order No.	JZSP-CMP9-1-E
Manufacturer	Molex Japan Co., Ltd.
Connector Model (For standard)	55100-0670 (soldered)
External Dimensions (Units: mm)	

Note: The mating connector model on SERVOPACK: 54280-800
The mating connector model on servomotor: 55102-0600



(4) Cable Specifications

Items	Standard Type	Flexible Type
Order No.*	JZSP-CMP09-□□-E	JZSP-CSP39-□□-E
Cable Length	20 m max.	
Specifications	UL20276 (Rating temperature: 80°C) AWG22×2C+AWG24×2P AWG22 (0.33 mm ²) Outer diameter of insulating sheath: 1.15 dia. AWG24 (0.20 mm ²) Outer diameter of insulating sheath: 1.09 dia.	UL20276 (Rating temperature: 80°C) AWG22×2C+AWG24×2P AWG22 (0.33 mm ²) Outer diameter of insulating sheath: 1.35 dia. AWG24 (0.20 mm ²) Outer diameter of insulating sheath: 1.21 dia.
Finished Dimensions	6.5 dia.	6.8 dia.
Internal Configuration and Lead Color		
Yaskawa Standards Specifications (Standard Length)	Cable length: 5 m, 10 m, 15 m, 20 m	

*: Specify the cable length in □□ of order no.
Example: JZSP-CMP09-05-E (5 m)

Selecting Cables

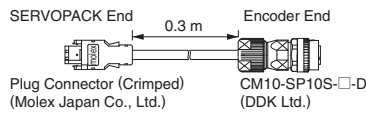
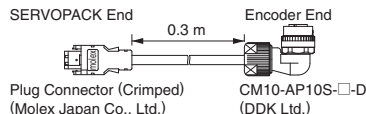
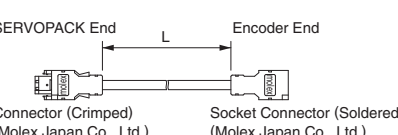
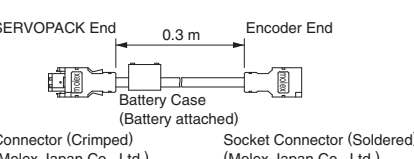
●Encoder Cables (For extending from 30 to 50 m)

Name	Length	Order No.	Specifications	Details
① Encoder-end Cables (For incremental and absolute encoder)	0.3 m	JZSP-CVP01-E	 <p>SERVOPACK End 0.3 m Encoder End</p> <p>Plug Connector (Crimped) CM10-SP10S-□-D (Molex Japan Co., Ltd.) (DDK Ltd.)</p>	(1)
		JZSP-CVP02-E	 <p>SERVOPACK End 0.3 m Encoder End</p> <p>Plug Connector (Crimped) CM10-AP10S-□-D (Molex Japan Co., Ltd.) (DDK Ltd.)</p>	
② Cable with Connectors (For incremental and absolute encoder)	30 m	JZSP-UCMP00-30-E	 <p>SERVOPACK End L Encoder End</p> <p>Connector (Crimped) Socket Connector (Soldered) (Molex Japan Co., Ltd.) (Molex Japan Co., Ltd.)</p>	(2)
	40 m	JZSP-UCMP00-40-E		
	50 m	JZSP-UCMP00-50-E		
③ Cable with a Battery Case (Required when an absolute encoder is used.)	0.3 m	JZSP-CSP12-E*	 <p>SERVOPACK End 0.3 m Encoder End</p> <p>Connector (Crimped) Battery Case Socket Connector (Soldered) (Molex Japan Co., Ltd.) (Battery attached) (Molex Japan Co., Ltd.)</p>	(3)
④ Cables	30 m	JZSP-CMP19-30-E		(4)
	40 m	JZSP-CMP19-40-E		
	50 m	JZSP-CMP19-50-E		

*: When using an incremental encoder or using an absolute encoder with a battery connected to the host controller, no battery case is required.

Selecting Cables

(1) Wiring Specifications for Encoder-end Cable (For incremental and absolute encoder)

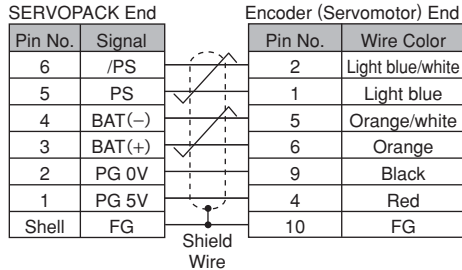

Note: The signals BAT(+) and BAT(-) are used when using an absolute encoder.

(2) Wiring Specifications for Cable with Connectors (For incremental and absolute encoder)

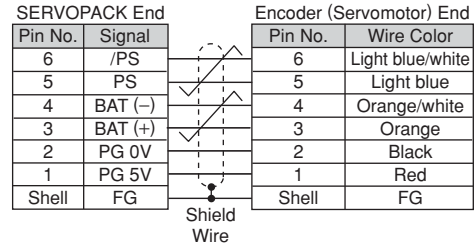

(3) Wiring Specifications for Cable with a Battery Case (For absolute encoder)

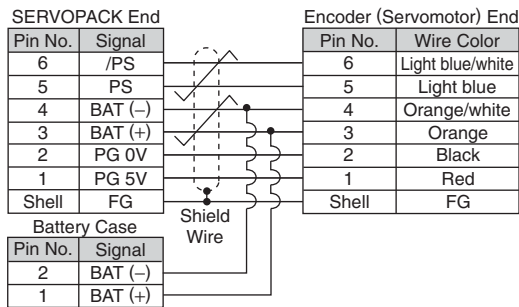

(4) Cable Specifications

Item	Standard Type
Order No.*	JZSP-CMP19-□□-E
Cable Length	50 m max.
Specifications	UL20276 (Rating temperature: 80°C) AWG16×2C+AWG26×2P AWG16 (1.31 mm ²) Outer diameter of insulating sheath: 2.0 dia. AWG26 (0.13 mm ²) Outer diameter of insulating sheath: 0.91 dia.
Finished Dimensions	6.8 dia.
Internal Configuration and Lead Colors	
Yaskawa Standard Specifications (Standard Length)	Cable length: 30 m, 40 m, 50 m

*: Specify the cable length in □□ of order no.
Example: JZSP-CMP19-30-E (30 m)

Rotary Servomotors

SGMSV



Model Designations

SGMSV - 10 A D A 2 1
Σ-V Series Servomotor SGMSV
1st+2nd digits
3rd digit
4th digit
5th digit
6th digit
7th digit

1st+2nd digits Rated Output

Code	Specifications
10	1.0 kW
15	1.5 kW
20	2.0 kW
25	2.5 kW
30	3.0 kW
40	4.0 kW
50	5.0 kW
70	7.0 kW*

*: Available only for 200-VAC models.

3rd digit Power Supply Voltage

Code	Specifications
A	200 VAC
D	400 VAC

4th digit Serial Encoder

Code	Specifications
3	20-bit absolute (standard)
D	20-bit incremental (standard)

5th digit Design Revision Order

Code	Specifications
A	Standard

6th digit Shaft End

Code	Specifications
2	Straight without key (standard)
6	Straight with key and tap (optional)

7th digit Options

Code	Specifications
1	Without options
B	With holding brake (90 VDC)
C	With holding brake (24 VDC)
D	With oil seal and holding brake (90 VDC)
E	With oil seal and holding brake (24 VDC)
S	With oil seal

Features

- Super high power
- Wide selection: 1.0 kW to 7.0 kW capacity, holding brake option
- Mounted serial encoder: 20 bits, high resolution
- Protective structure : IP67 (Not including the IP22 compliant enclosure for 7.0 kW motor)

Application Examples

- Chip mounters
- PCB drilling stations
- Machine tool feeders

Configurations of connectors for the main circuit



SGMSV-10 to -70

The connectors for these models are round. The connectors specified by Yaskawa are required. Note that the connectors vary depending on the operation environment of servomotors.

Two types of connectors are available.

- Standard connectors

For details, refer to page 103 to 105.

- Protective structure IP67 and European Safety Standards compliant connectors

For details, refer to page 106 and 107.

Note: Connectors are not provided by Yaskawa.

Ratings and Specifications

Time Rating: Continuous
Vibration Class: V15
Insulation Resistance: 500 VDC, 10 MΩ min.
Ambient Temperature: 0 to 40°C
Excitation: Permanent magnet
Mounting: Flange-mounted
Thermal Class: F

Withstand Voltage: 1500 VAC for one minute (200-V class)
 1800 VAC for one minute (400-V class)

Enclosure: Totally enclosed, self-cooled, IP67
 (except for shaft opening)

Note: IP22 for SGMSV-70 servomotors.

Ambient Humidity: 20% to 80% (no condensation)

Drive Method: Direct drive

Rotation Direction: Counterclockwise (CCW) with forward run
 reference when viewed from the load side

200-V Class

Servomotor Model: SGMSV-□□□□		10A	15A	20A	25A	30A	40A	50A	70A
Rated Output*	kW	1.0	1.5	2.0	2.5	3.0	4.0	5.0	7.0
Rated Torque*	N·m	3.18	4.90	6.36	7.96	9.80	12.6	15.8	22.3
Instantaneous Peak Torque*	N·m	9.54	14.7	19.1	23.9	29.4	37.8	47.6	54
Rated Current*	Arms	5.7	9.3	12.1	13.8	17.9	25.4	27.6	38.3
Instantaneous Max. Current*	Arms	17	28	42	44.5	56	77	84	105
Rated Speed*	min ⁻¹	3000							
Max. Speed*	min ⁻¹	6000	5000						
Torque Constant	N·m/Arms	0.636	0.590	0.561	0.610	0.582	0.519	0.604	0.604
Rotor Moment of Inertia	×10 ⁻⁴ kg·m ²	1.74 (1.99)	2.00 (2.25)	2.47 (2.72)	3.19 (3.44)	7.00 (9.2)	9.60 (11.8)	12.3 (14.5)	12.3
Rated Power Rate*	kW/s	58 (51)	120 (107)	164 (149)	199 (184)	137 (104)	165 (135)	203 (172)	404
Rated Angular Acceleration*	rad/s ²	18300 (16000)	24500 (21800)	25700 (23400)	25000 (23100)	14000 (10700)	13100 (10700)	12800 (10900)	18100
Applicable SERVOPACK	SGDV-□□□□	7R6A	120A	180A	200A	200A	330A	330A	550A

*: These items and torque-motor speed characteristics quoted in combination with a SERVOPACK are at an armature winding temperature of 20°C.
 Notes: 1 The values in parentheses are for servomotors with holding brakes.

2 The above specifications show the values under the cooling condition when the following heat sinks are mounted on the servomotors.

SGMSV-10A/-15A/-20A/-25A : 300 mm×300 mm×12 mm (aluminum)
 SGMSV-30A/-40A/-50A/-70A : 400 mm×400 mm×20 mm (aluminum)

400-V Class

Servomotor Model: SGMSV-□□□□		10D	15D	20D	25D	30D	40D	50D
Rated Output*	kW	1.0	1.5	2.0	2.5	3.0	4.0	5.0
Rated Torque*	N·m	3.18	4.9	6.36	7.96	9.8	12.6	15.8
Instantaneous Peak Torque*	N·m	9.54	14.7	19.1	23.9	29.4	37.8	47.6
Rated Current*	Arms	2.8	4.7	6.1	7.4	8.9	12.5	13.8
Instantaneous Max. Current*	Arms	8.5	14	20	25	28	38	42
Rated Speed*	min ⁻¹	3000						
Max. Speed*	min ⁻¹	6000	5000					
Torque Constant	N·m/Arms	1.27	1.23	1.18	1.15	1.16	1.06	1.21
Rotor Moment of Inertia	×10 ⁻⁴ kg·m ²	1.74 (1.99)	2.00 (2.25)	2.47 (2.72)	3.19 (3.44)	7.00 (9.2)	9.60 (11.8)	12.3 (14.5)
Rated Power Rate*	kW/s	58 (51)	120 (107)	164 (149)	199 (184)	137 (104)	165 (135)	203 (172)
Rated Angular Acceleration*	rad/s ²	18300 (16000)	24500 (21800)	25700 (23400)	25000 (23100)	14000 (10700)	13100 (10700)	12800 (10900)
Applicable SERVOPACK	SGDV-□□□□	3R5D	5R4D	8R4D	120D	120D	170D	170D

*: These items and torque-motor speed characteristics quoted in combination with a SERVOPACK are at an armature winding temperature of 20°C.
 Notes: 1 The values in parentheses are for servomotors with holding brakes.

2 The above specifications show the values under the cooling condition when the following heat sinks are mounted on the servomotors.

SGMSV-10D/-15D/-20D/-25D : 300 mm×300 mm×12 mm (aluminum)
 SGMSV-30D/-40D/-50D : 400 mm×400 mm×20 mm (aluminum)

Ratings and Specifications

● Torque-Motor Speed Characteristics (200 V/400 V) A: Continuous Duty Zone B: Intermittent Duty Zone ^(Note1)

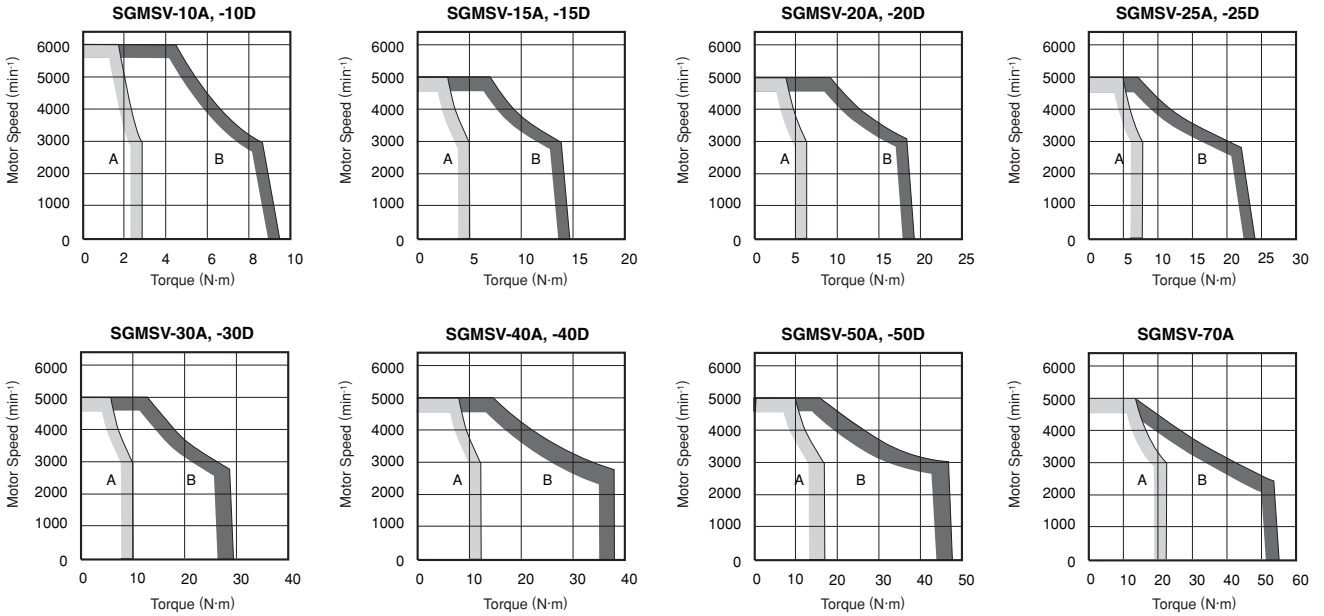

Note: 1 When the effective torque during intermittent duty is within the rated torque, the servomotor can be used within the intermittent duty zone.
 2 When the main circuit cable length exceeds 20 m, note that the intermittent duty zone of the *Torque-Motor Speed Characteristics* will shrink as the line-to-line voltage drops.

● Holding Brake Electrical Specifications

Servomotor Model	Servomotor Rated Output kW	Holding Brake Specifications				
		Holding Torque N·m	Rated Voltage 24 VDC		Rated Voltage 90 VDC	
			Capacity W	Rated Current A (at 20°C)	Capacity W	Rated Current A (at 20°C)
SGMSV-10	1.0	7.84	12	0.5	12	0.13
SGMSV-15	1.5	7.84	12	0.5	12	0.13
SGMSV-20	2.0	7.84	12	0.5	12	0.13
SGMSV-25	2.5	10	12	0.5	12	0.13
SGMSV-30	3.0	20	10	0.41	10	0.11
SGMSV-40	4.0	20	10	0.41	10	0.11
SGMSV-50	5.0	20	10	0.41	10	0.11

Notes: 1 The holding brake is only used to hold the load and cannot be used to stop the servomotor.
 2 The holding brake open time and holding brake operation time vary depending on which discharge circuit is used. Make sure holding brake open time and holding brake operation time are correct for your servomotor.
 3 A 24 VDC power supply is to be provided by customers.
 4 For information on a 90 VDC power supply, refer to page 359.

Ratings and Specifications

● Allowable Load Moment of Inertia at the Motor Shaft

The rotor moment of inertia ratio is the value for a servomotor without a gear and a holding brake.

Servomotor Model	Servomotor Rated Output	Allowable Load Moment of Inertia (Rotor Moment of Inertia Ratio)
SGMSV-10 to -70	1.0 to 7.0 kW	5 times

● Load Moment of Inertia

The larger the load moment of inertia, the worse the movement response.

The allowable load moment of inertia (J_L) depends on the motor capacity, as shown above. This value is provided strictly as a guideline and results may vary depending on servomotor drive conditions.

Use the AC servo drive capacity selection program SigmaJunmaSize+ to check the operation conditions. The program can be downloaded for free from our web site (<http://www.e-mechatronics.com/>).

An overvoltage alarm (A.400) is likely to occur during deceleration if the load moment of inertia exceeds the allowable load moment of inertia. SERVOPACKs with a built-in regenerative resistor may generate a regenerative overload alarm (A.320). Take one of the following steps if this occurs.

- Reduce the torque limit.
- Reduce the deceleration rate.
- Reduce the maximum speed.
- Install an external regenerative resistor if the alarm cannot be cleared using the steps above. Refer to *Regenerative Resistors* on page 360.

● Allowable Radial and Thrust Loads

Design the mechanical system so thrust and radial loads applied to the servomotor shaft end during operation fall within the ranges shown in the table.

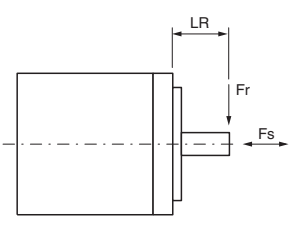
Servomotor Model	Allowable Radial Load (F_r) N	Allowable Thrust Load (F_s) N	LR mm	Reference Diagram	
SGMSV-	10□□A21	686	196	45	
	15□□A21				
	20□□A21				
	25□□A21	980	392	63	
	30□□A21				
	40□□A21				
	50□□A21				
70□□A21	1176				

External Dimensions Units: mm

● Without Holding Brakes
(1) 1.0 to 5.0 kW

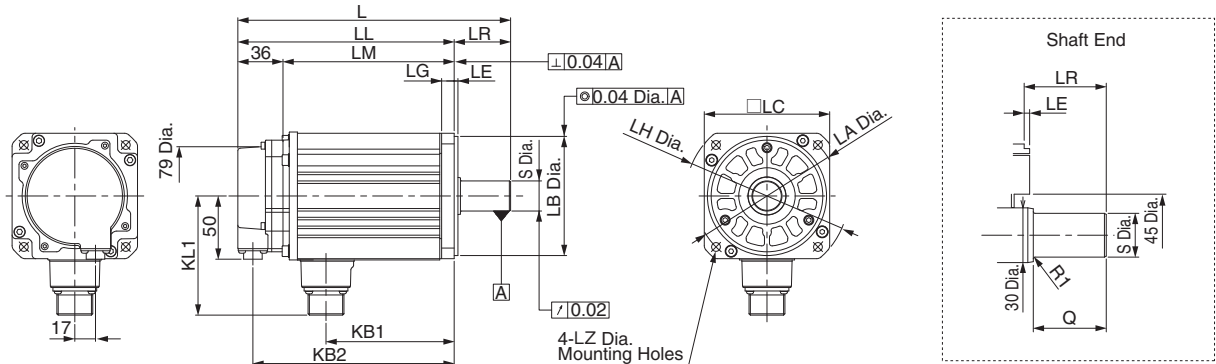

Note: For the specifications of the other shaft ends, refer to page 101.

Model SGMSV-	L	LL	LM	LR	KB1	KB2	KL1	Flange Face Dimensions							Shaft End Dimensions		Approx. Mass kg	
								LA	LB	LC	LE	LF	LG	LH	LZ	S		Q
10□□A21	192	147	111	45	76	135	96	115	95 ⁰ _{-0.035}	100	3	3	10	130	7	24 ⁰ _{-0.013}	40	4.1
15□□A21	202	157	121	45	86	145	96	115	95 ⁰ _{-0.035}	100	3	3	10	130	7	24 ⁰ _{-0.013}	40	4.6
20□□A21	218	173	137	45	102	161	96	115	95 ⁰ _{-0.035}	100	3	3	10	130	7	24 ⁰ _{-0.013}	40	5.4
25□□A21	241	196	160	45	125	184	96	115	95 ⁰ _{-0.035}	100	3	3	10	130	7	24 ⁰ _{-0.013}	40	6.8
30□□A21	259	196	160	63	124	184	114	145	110 ⁰ _{-0.035}	130	6	6	12	165	9	28 ⁰ _{-0.013}	55	10.5
40□□A21	296	233	197	63	161	221	114	145	110 ⁰ _{-0.035}	130	6	6	12	165	9	28 ⁰ _{-0.013}	55	13.5
50□□A21	336	273	237	63	201	261	114	145	110 ⁰ _{-0.035}	130	6	6	12	165	9	28 ⁰ _{-0.013}	55	16.5

Note: Models with oil seals are of the same configuration.

• Cable Specifications for Encoder-end Connector
(20-bit Encoder)

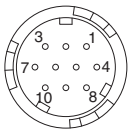

Receptacle: CM10-R10P-D
Applicable plug (To be provided by the customer)
Plug: CM10-AP10S-□-D (Angle)
CM10-SP10S-□-D (Straight)
(Boxes □ indicate a value that varies, depending on cable size.)
Manufacturer : DDK Ltd.

With an Absolute Encoder

1	PS	6	BAT (+)
2	/PS	7	-
3	-	8	-
4	PG 5V	9	PG 0V
5	BAT (-)	10	FG (Frame ground)

With an Incremental Encoder

1	PS	6	-
2	/PS	7	-
3	-	8	-
4	PG 5V	9	PG 0V
5	-	10	FG (Frame ground)

• Cable Specifications for Servomotor-end Connector

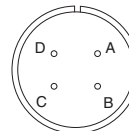

A	Phase U
B	Phase V
C	Phase W
D	FG (Frame ground)

• SGMSV-10 to -25
Manufacturer : DDK Ltd.
• SGMSV-30 to -50
Manufacturer : Japan Aviation
Electronics
Industry, Ltd.

External Dimensions Units: mm

(2) 7.0 kW (only for 200 V servomotors)

Note: Leave a minimum space of 70 mm around the servomotor to allow for a sufficient amount of cooling air.

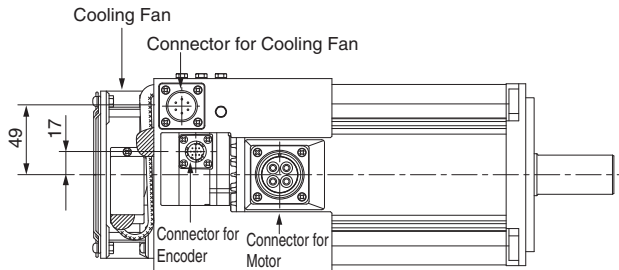
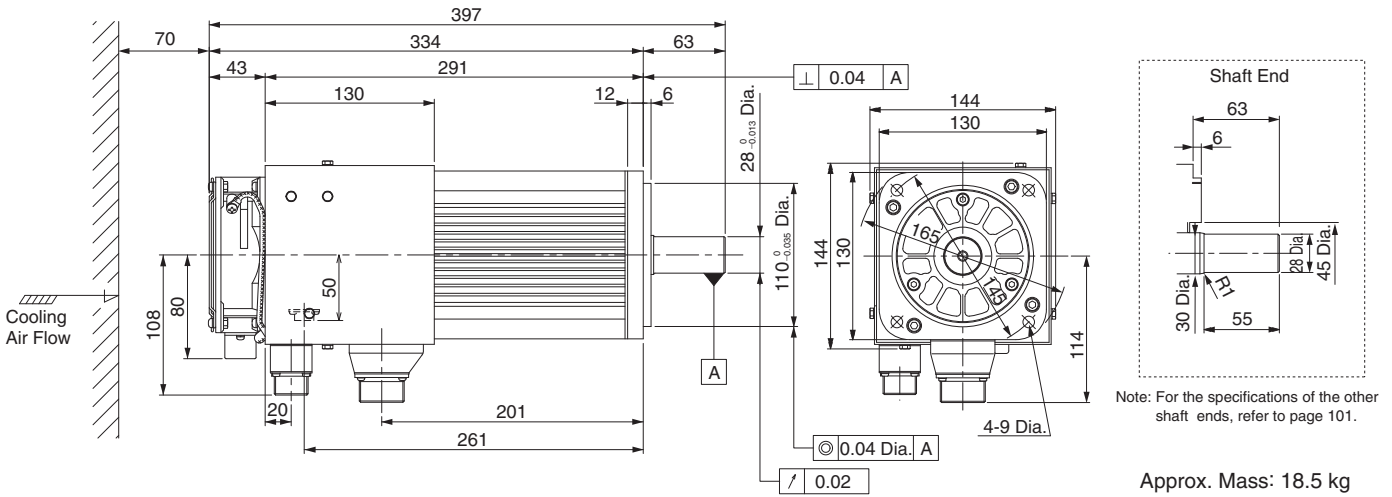

- Specifications of Cooling Fan
 - Single-phase 220 V
 - 50/60 Hz
 - 17/15 W
 - 0.11/0.09 A
- Specifications of rotation error detector
 - Contact Capacity:
 - Max. allowable voltage: 350 V (AC, DC)
 - Max. allowable current: 120 mA (AC, DC)
 - Max. controllable power: 360 mW
 - Alarm Contact:
 - ON at normal fan rotation.
 - OFF at 1680±100 min⁻¹ or less.
 - (OFF during 3 seconds at start-up)

· Cable Specifications for Servomotor-end Connector

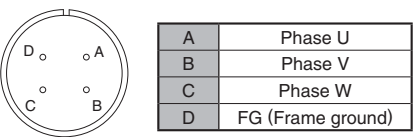

Manufacturer: Japan Aviation Electronics Industry, Ltd.

· Cable Specifications for Fan-end Connector

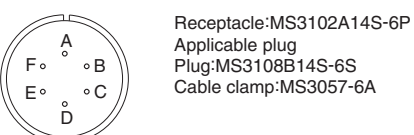

Note: Servomotor-end connectors (receptacles) are RoHS-compliant. Contact the respective connector manufacturers for RoHS-compliant cable-end connectors.

A	Fan motor
B	Fan motor
C	-
D	Alarm terminal
E	Alarm terminal
F	FG (Frame ground)

· Cable Specifications for Encoder-end Connector (20-bit Encoder)

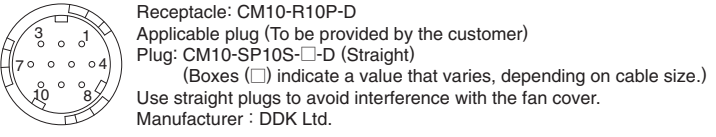

With an Absolute Encoder

1	PS	6	BAT (+)
2	/PS	7	-
3	-	8	-
4	PG 5V	9	PG 0V
5	BAT (-)	10	FG (Frame ground)

With an Incremental Encoder

1	PS	6	-
2	/PS	7	-
3	-	8	-
4	PG 5V	9	PG 0V
5	-	10	FG (Frame ground)

External Dimensions Units: mm

● **With Holding Brakes**
(1) 1.0 to 5.0 kW

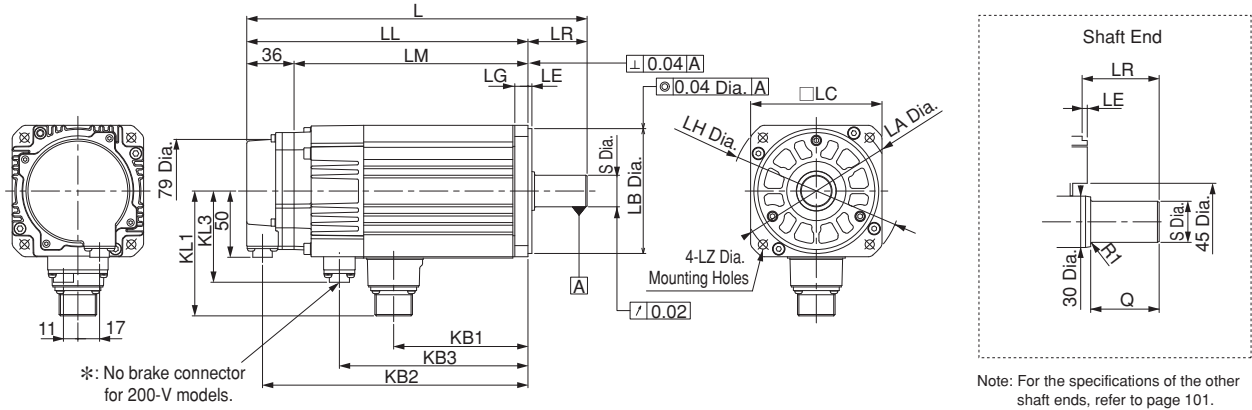

Model SGMSV-	L	LL	LM	LR	KB1			KB3*	KL1		KL3*	Flange Face Dimensions							Shaft End Dimensions		Approx. Mass kg	
					200V	400V	KB2		400V	200V		400V	LA	LB	LC	LE	LF	LG	LH	LZ		S
10□□A2□	233	188	152	45	67	76	176	118	102	96	69	115	95 ⁰ _{-0.035}	100	3	3	10	130	7	24 ⁰ _{-0.013}	40	5.5
15□□A2□	243	198	162	45	77	86	186	128	102	96	69	115	95 ⁰ _{-0.035}	100	3	3	10	130	7	24 ⁰ _{-0.013}	40	6
20□□A2□	259	214	178	45	93	102	202	144	102	96	69	115	95 ⁰ _{-0.035}	100	3	3	10	130	7	24 ⁰ _{-0.013}	40	6.8
25□□A2□	292	247	211	45	116	125	225	177	102	96	69	115	95 ⁰ _{-0.035}	100	3	3	10	130	7	24 ⁰ _{-0.013}	40	8.7
30□□A2□	295	232	196	63	114	124	220	176	119	114	81	145	110 ⁰ _{-0.035}	130	6	6	12	165	9	28 ⁰ _{-0.013}	55	13
40□□A2□	332	269	233	63	151	161	257	213	119	114	81	145	110 ⁰ _{-0.035}	130	6	6	12	165	9	28 ⁰ _{-0.013}	55	16
50□□A2□	372	309	273	63	191	201	297	253	119	114	81	145	110 ⁰ _{-0.035}	130	6	6	12	165	9	28 ⁰ _{-0.013}	55	19

*: No brake connector for 200-V models (there are brake terminals on the servomotor-end connectors).
Note: Models with oil seals are of the same configuration.

• Cable Specifications for Encoder-end Connector (20-bit Encoder)

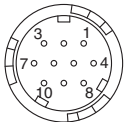

Receptacle: CM10-R10P-D
Applicable plug (To be provided by the customer)
Plug: CM10-AP10S-□-D (Angle)
CM10-SP10S-□-D (Straight)
(Boxes (□) indicate a value that varies, depending on cable size.)
Manufacturer: DDK Ltd.

With an Absolute Encoder

1	PS	6	BAT (+)
2	/PS	7	-
3	-	8	-
4	PG 5V	9	PG 0V
5	BAT (-)	10	FG (Frame ground)

With an Incremental Encoder

1	PS	6	-
2	/PS	7	-
3	-	8	-
4	PG 5V	9	PG 0V
5	-	10	FG (Frame ground)

200-V Class

• Cable Specifications for Servomotor-end Connector

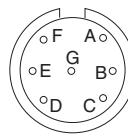

A	Phase U
B	Phase V
C	Phase W
D	FG (Frame ground)
E	Brake terminal
F	Brake terminal
G	-

Manufacturer: Japan Aviation Electronics Industry, Ltd.

Note: No polarity for connection to the brake terminals

400-V Class

• Cable Specifications for Servomotor-end Connector

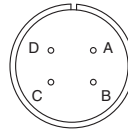

A	Phase U
B	Phase V
C	Phase W
D	FG (Frame ground)

• SGMSV-10 to -25
Manufacturer: DDK Ltd.
• SGMSV-30 to -50
Manufacturer: Japan Aviation Electronics Industry, Ltd.

• Cable Specifications for Brake-end Connector

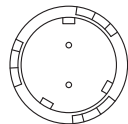

Receptacle: CM10-R2P-D
Applicable plug (To be provided by the customer)
Plug: CM10-AP2S-□-D (Angle)
CM10-SP2S-□-D (Straight)
(Boxes (□) indicate a value that varies, depending on cable size.)
Manufacturer: DDK Ltd.

Brake terminal
Brake terminal

Note: No polarity for connection to the brake terminals

External Dimensions Units: mm

● Shaft End

SGMSV - □□□□□□□□

Code	Specifications	Remarks
2	Straight without key	Standard
6	Straight with key and tap for one location (Key slot is JIS B1301-1996 fastening type)	Optional

Code	Specifications	Shaft End	Model SGMSV-							
			10	15	20	25	30	40	50	70
2	Straight without Key		LR	45				63		
			Q	40				55		
			S	24 ⁰ _{-0.013}				28 ⁰ _{-0.013}		
6	Straight with Key and Tap		LR	45				63		
			Q	40				55		
			QK	32				50		
			S	24 ⁰ _{-0.013}				28 ⁰ _{-0.013}		
			W	8						
			T	7						
			U	4						
P	M8 Screw Depth16									

Selecting Cables

● Cables Connections

- Standard Wiring (Max. encoder cable length: 20 m)
- Encoder Cable Extension from 30 to 50 m (See page 110.)

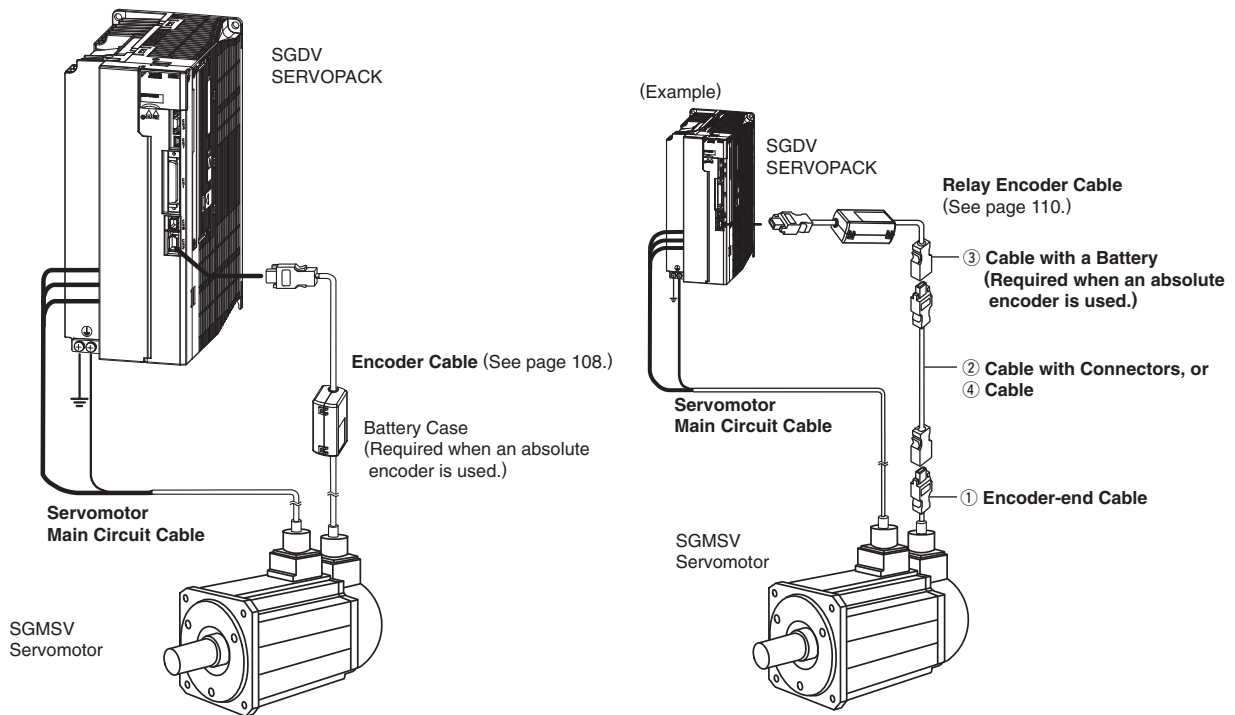

⚠ CAUTION

- Separate the servomotor main circuit cable wiring from the I/O signal cable and encoder cable at least 30 cm, and do not bundle or run them in the same duct.
- When the main circuit cable length exceeds 20 m, note that the intermittent duty zone of the *Torque-Motor Speed Characteristics* will shrink as the line-to-line voltage drops.

● Servomotor Main Circuit Cables

Customers must assemble the servomotor's main circuit cables and attach connectors to connect the SERVOPACKs and the SGMSV servomotors.

The connectors for these models are round. The connectors specified by Yaskawa are required. Note that the connectors vary depending on the operation environment of servomotors.

Two types of connectors are available.

- Standard connectors
- Protective structure IP67 and European Safety Standards compliant connectors

Yaskawa does not specify which cables to use. Use appropriate cables for the connectors.

Selecting Cables

● Standard Connectors

● Connector Configuration

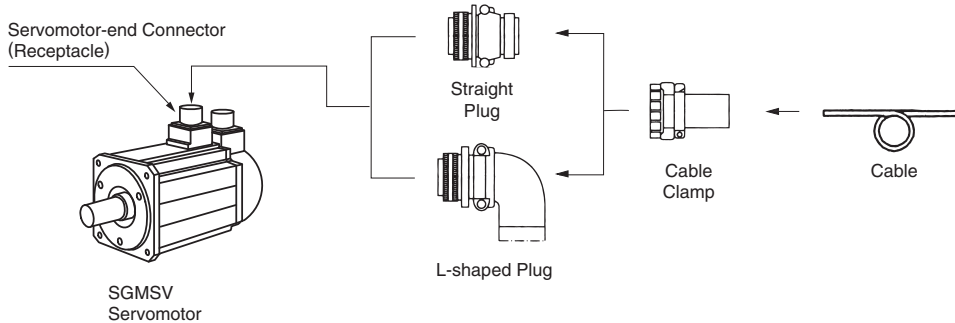

(1) Without Holding Brakes

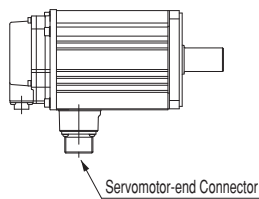

Servomotor-end Connector
For 1.0 to 7.0 kW

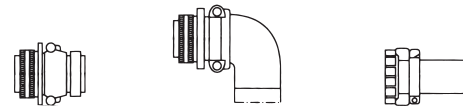

Capacity kW	Servomotor-end Connector (Receptacle)	Cable-end Connector (Not provided by Yaskawa)		
		Straight Plug	L-shaped Plug	Cable Clamp
1.0 to 2.5	MS3102A18-10P	MS3106B18-10S	MS3108B18-10S	MS3057-10A
3.0 to 7.0	MS3102A22-22P	MS3106B22-22S	MS3108B22-22S	MS3057-12A

Note: Servomotor-end connectors (receptacles) are RoHS-compliant. Contact the respective connector manufacturers for RoHS-compliant cable-end connectors.

(2) With Holding Brakes (200 V)

No brake connector for 200-V models (there are brake terminals on the servomotor-end connectors).

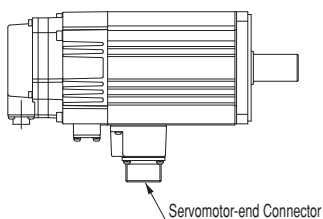

Servomotor-end Connector
For 1.0 to 5.0 kW

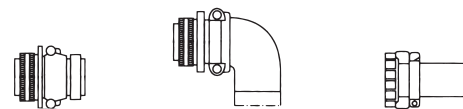

Capacity kW	Servomotor-end Connector (Receptacle)	Cable-end Connector (Not provided by Yaskawa)		
		Straight Plug	L-shaped Plug	Cable Clamp
1.0 to 2.5	MS3102A20-15P	MS3106B20-15S	MS3108B20-15S	MS3057-12A
3.0 to 5.0	MS3102A24-10P	MS3106B24-10S	MS3108B24-10S	MS3057-16A

Note: Servomotor-end connectors (receptacles) are RoHS-compliant. Contact the respective connector manufacturers for RoHS-compliant cable-end connectors.

Selecting Cables

(3) With Holding Brakes (400 V)

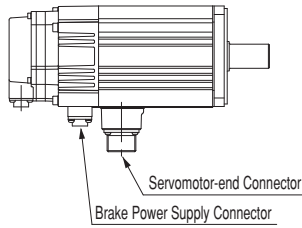

Servomotor-end Connector
For 1.0 to 5.0 kW

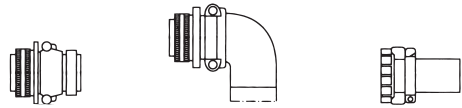

Capacity kW	Servomotor-end Connector (Receptacle)	Cable-end Connector (Not provided by Yaskawa)		
		Straight Plug	L-shaped Plug	Cable Clamp
1.0 to 2.5	MS3102A18-10P	MS3106B18-10S	MS3108B18-10S	MS3057-10A
3.0 to 5.0	MS3102A22-22P	MS3106B22-22S	MS3108B22-22S	MS3057-12A

Note: Servomotor-end connectors (receptacles) are RoHS-compliant. Contact the respective connector manufacturers for RoHS-compliant cable-end connectors.

Brake Power Supply Connector
For 1.0 to 5.0 kW

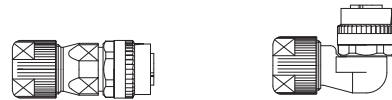

Capacity kW	Servomotor-end Connector (Receptacle)	Cable-end Connector (Not provided by Yaskawa)		
		Straight Plug	L-shaped Plug	Manufacturer
1.0 to 5.0	CM10-R2P-D	CM10-SP2S-S-D Applicable Cable: 4.0 dia. to 6.0 dia.	CM10-AP2S-S-D Applicable Cable: 4.0 dia. to 6.0 dia.	DDK Ltd.
		CM10-SP2S-M-D Applicable Cable: 6.0 dia. to 9.0 dia.	CM10-AP2S-M-D Applicable Cable: 6.0 dia. to 9.0 dia.	
		CM10-SP2S-L-D Applicable Cable: 9.0 dia. to 11.6 dia.	CM10-AP2S-L-D Applicable Cable: 9.0 dia. to 11.6 dia.	

To order a brake power supply connector kit (1.0 to 5.0 kW) with the order no. below, contact your Yaskawa representative.

J Z S P - C V B 9 - S M S 2 - E

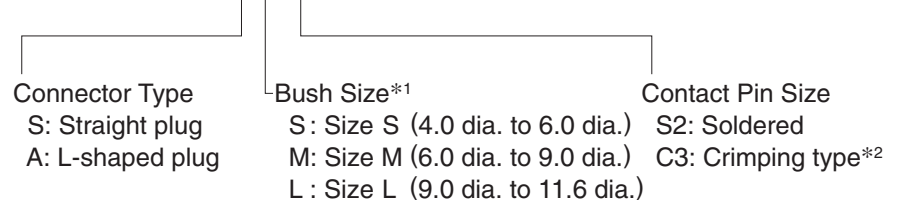

*1: A size-M connector kit is available as standard equipment.
*2: A crimp tool (model: 357J-50448T) by DDK Ltd. is required.

Selecting Cables Units: mm

• Cable-end Connectors

(1) MS3106B□□-□□S : Straight Plug

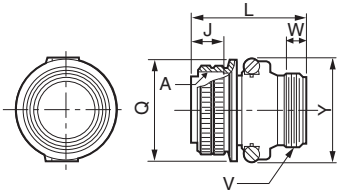

Shell Size	Joint Screw A	Length of Joint Portion J±0.12	Overall Length L max.	Outer Diameter of Joint Nut Q ⁺⁰ _{-0.38}	Cable Clamp Set Screw V	Effective Screw Length W min.	Maximum Width Y max.
18	1-1/8-18UNEF	18.26	52.37	34.13	1-20UNEF	9.53	42
20	1-1/4-18UNEF	18.26	55.57	37.28	1-3/16-18UNEF	9.53	47
22	1-3/8-18UNEF	18.26	55.57	40.48	1-3/16-18UNEF	9.53	50
24	1-1/2-18UNEF	18.26	58.72	43.63	1-7/16-18UNEF	9.53	53

(2) MS3108B□□-□□S : L-shaped Plug

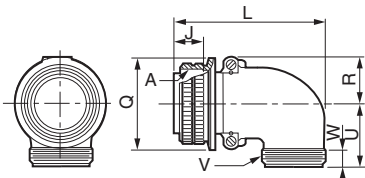

Shell Size	Joint Screw A	Length of Joint Portion J±0.12	Overall Length L max.	Outer Diameter of Joint Nut Q ⁺⁰ _{-0.38}	R ±0.5	U ±0.5	Cable Clamp Set Screw V	Effective Screw Length W min.
18	1-1/8-18UNEF	18.26	68.27	34.13	20.5	30.2	1-20UNEF	9.53
20	1-1/4-18UNEF	18.26	76.98	37.28	22.5	33.3	1-3/16-18UNEF	9.53
22	1-3/8-18UNEF	18.26	76.98	40.48	24.1	33.3	1-3/16-18UNEF	9.53
24	1-1/2-18UNEF	18.26	86.51	43.63	25.6	36.5	1-7/16-18UNEF	9.53

(3) MS3057-□□A : Cable Clamp with Rubber Bushing

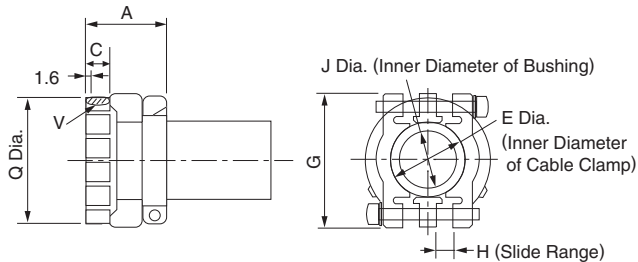

Cable Clamp Type	Applicable Connector Shell Size	Overall Length A±0.7	Effective Screw Length C	E Diameter	G±0.7	H	J Diameter	Set Screw V	Outer Diameter Q±0.7 Dia.	Attached Bushing
MS3057-10A	18	23.8	10.3	15.9	31.7	3.2	14.3	1-20UNEF	30.1	AN3420-10
MS3057-12A	20, 22	23.8	10.3	19	37.3	4	15.9	1-3/16-18UNEF	35.0	AN3420-12
MS3057-16A	24	26.2	10.3	23.8	42.9	4.8	19.1	1-7/16-18UNEF	42.1	AN3420-16

• Dimensional Drawings of Brake Power Supply

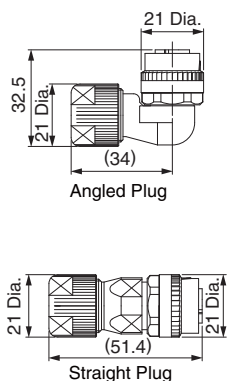

Items	Specifications
Connector Order No.	CM10- □P2S-□ -D (Cables are not included.)
Protective Structure	IP67
Manufacturer	DDK Ltd.
Instructions	Angled plug (CM10-AP2S- □ -D): TC-573, Straight plug (CM10-SP2S- □ -D): TC-583
Electrical Contact Order No.	<p>Electrical contact (100 pcs in one bag)</p> <ul style="list-style-type: none"> · Crimping type: CM10-#22SC(C3)-100, Wire size: AWG16 to 20, Outer diameter of sheath: 1.87 to 2.45 dia., Hand tool: 357J-50448T · Soldered type: CM10-#22SC (S2)-100, Wire size: AWG16 max. <p>Real contact (4000 pcs on one reel)</p> <ul style="list-style-type: none"> · Crimping type: CM10-#22SC(C3)-4000, Wire size: AWG 16 to 20, Outer diameter of sheath: 1.87 to 2.45 dia., Semi-automatic tool: AP-A50541T (product name for one set), AP-A50541T-1 (product name for applicator) <p>Note: The product name of the semi-automatic tool refers to the product name of the press and applicator (crimper) as a set.</p>

Selecting Cables

● Protective Structure IP67 and European Safety Standards Compliant Connector

● Connector Configuration

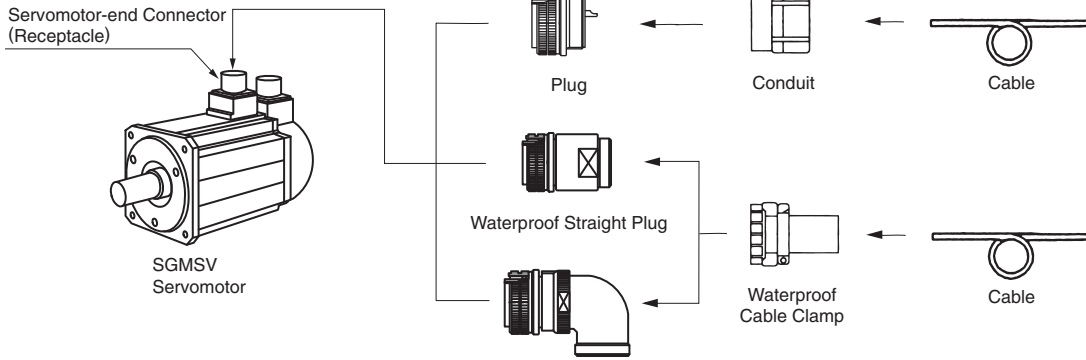

Waterproof L-shaped Plug

Note: For the conduit grounding, contact the manufacturer of the conduit being used.

(1) Without Holding Brakes

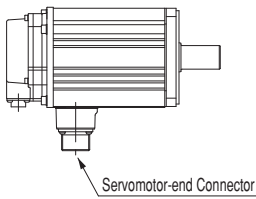

Servomotor-end Connector
For 1.0 to 7.0 kW



Capacity kW	Servomotor-end Connector (Receptacle)	Cable-end Connector (Not Provided by Yaskawa)				Applicable Cable Diameter (For Reference)	Manufacturer
		Plug	Straight Plug	L-shaped Plug	Cable Clamp		
1.0 to 2.5	CE05-2A18-10PD-D	CE05-6A18-10SD-D	CE05-6A18-10SD-D-BSS	CE05-8A18-10SD-D-BAS	CE3057-10A-1-D	10.5 dia. to 14.1 dia.	DDK Ltd.
					CE3057-10A-2-D	8.5 dia. to 11.0 dia.	
					CE3057-10A-3-D	6.5 dia. to 8.7 dia.	
3.0 to 7.0	JL04HV-2E22-22PE-B-R	JL04V-6A22-22SE-R	JL04V-6A22-22SE-EB-R or JA06A-22-22S-J1-EB-R*	JL04V-8A22-22SE-EB-R or JA08A-22-22S-J1-EB-R*	JL04-2022CK (09) -R	6.5 Dia. to 9.5 Dia.	Japan Aviation Electronics Industry, Ltd.
					JL04-2022CK (12) -R	9.5 Dia. to 13.0 Dia.	
					JL04-2022CK (14) -R	12.9 Dia. to 15.9 Dia.	

*: Not compliant with European Safety Standards, but compliant with protective structure IP67.

(2) With Holding Brakes (200 V)

No brake connector for 200-V models (there are brake terminals on the servomotor-end connectors).

Servomotor-end Connector
For 1.0 to 5.0 kW

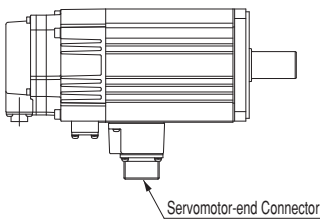
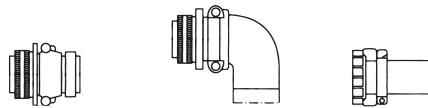

Capacity kW	Servomotor-end Connector (Receptacle)	Cable-end Connector (Not Provided by Yaskawa)				Applicable Cable Diameter (For Reference)	Manufacturer
		Plug	Straight Plug	L-shaped Plug	Cable Clamp		
1.0 to 2.5	JL04V-2E20-15PE-B-R	JL04V-6A20-15SE-R	JL04V-6A20-15SE-EB-R	JL04V-8A20-15SE-EB-R	JL04-2022CK (09) -R	6.5 Dia. to 9.5 Dia.	Japan Aviation Electronics Industry, Ltd.
					JL04-2022CK (12) -R	9.5 Dia. to 13.0 Dia.	
					JL04-2022CK (14) -R	12.9 Dia. to 15.9 Dia.	
3.0 to 5.0	JL04V-2E24-10PE-B-R	JL04-6A24-10SE-R	JL04V-6A24-10SE-EB-R or JA06A-24-10S-J1-EB-R*	JL04V-8A24-10SE-EB-R or JA08A-24-10S-J1-EB-R*	JL04-2428CK (11) -R	9.0 Dia. to 12.0 Dia.	Japan Aviation Electronics Industry, Ltd.
					JL04-2428CK (14) -R	12.0 Dia. to 15.0 Dia.	
					JL04-2428CK (17) -R	15.0 Dia. to 18.0 Dia.	
					JL04-2428CK (20) -R	18.0 Dia. to 20.0 Dia.	

*: Not compliant with European Safety Standards, but compliant with protective structure IP67.

Selecting Cables

(3) With Holding Brakes (400 V)

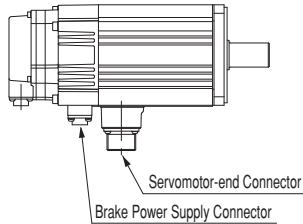

Servomotor-end Connector
For 1.0 to 5.0 kW



Capacity kW	Servomotor- end Connector (Receptacle)	Cable-end Connector (Not Provided by Yaskawa)					Applicable Cable Diameter (For Reference)	Manufacturer
		Plug	Straight Plug	L-shaped Plug	Cable Clamp			
1.0 to 2.5	CE05-2A18- 10PD-D	CE05- 6A18- 10SD-D	CE05-6A18- 10SD-D-BSS	CE05-8A18- 10SD-D-BAS	CE3057-10A-1-D	10.5 dia. to 14.1 dia.	DDK Ltd.	
					CE3057-10A-2-D	8.5 dia. to 11.0 dia.		
					CE3057-10A-3-D	6.5 dia. to 8.7 dia.		
3.0 to 5.0	JL04HV-2E22- 22PE-B-R	JL04V- 6A22- 22SE-R	JL04V-6A22SE-EB-R or JA06A-22-22S-J1-EB-R*	JL04V-8A22-22SE-EB-R or JA08A-22-22S-J1-EB-R*	JL04-2022CK (09) -R	6.5 Dia. to 9.5 Dia.	Japan Aviation Electronics Industry, Ltd.	
					JL04-2022CK (12) -R	9.5 Dia. to 13.0 Dia.		
					JL04-2022CK (14) -R	12.9 Dia. to 15.9 Dia.		

*: Not compliant with European Safety Standards, but compliant with protective structure IP67.

Brake Power Supply Connector
For 1.0 to 5.0 kW

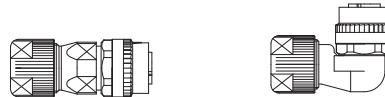

Capacity kW	Servomotor-end Connector (Receptacle)	Cable-end Connector (Not provided by Yaskawa)			Manufacturer
		Straight Plug	L-shaped Plug		
1.0 to 5.0	CM10-R2P-D	CM10-SP2S-S-D Applicable Cable: 4.0 dia. to 6.0 dia.	CM10-AP2S-S-D Applicable Cable: 4.0 dia. to 6.0 dia.	DDK Ltd.	
		CM10-SP2S-M-D Applicable Cable: 6.0 dia. to 9.0 dia.	CM10-AP2S-M-D Applicable Cable: 6.0 dia. to 9.0 dia.		
		CM10-SP2S-L-D Applicable Cable: 9.0 dia. to 11.6 dia.	CM10-AP2S-L-D Applicable Cable: 9.0 dia. to 11.6 dia.		

To order a brake power supply connector kit (1.0 to 5.0 kW)
with the order no. below, contact your Yaskawa representative.

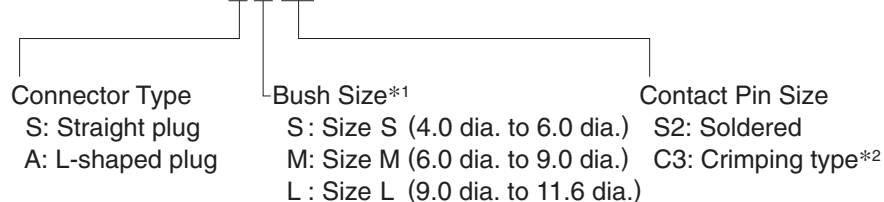

J Z S P - C V B 9 - S M S2 - E



*1: A size-M connector kit is available as standard equipment.
*2: A crimp tool (model: 357J-50448T) by DDK Ltd. is required.

Selecting Cables

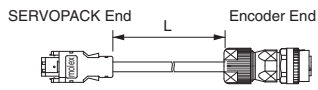
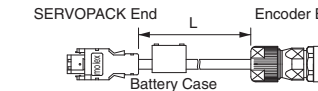
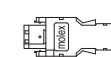
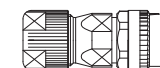
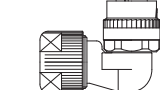
● Encoder Cables (Max. length: 20 m)

Name	Length (L)	Order No.		Specifications	Details
		Standard Type	Flexible Type*1		
Encoder Cable with Connectors (For Incremental Encoder)	3 m	JZSP-CVP01-03-E	JZSP-CVP11-03-E	 <p>SERVOPACK End L Encoder End</p> <p>Connector (Crimped) (Molex Japan Co., Ltd.) CM10-SP10S-□-D (DDK Ltd.)</p>	(1)
	5 m	JZSP-CVP01-05-E	JZSP-CVP11-05-E		
	10 m	JZSP-CVP01-10-E	JZSP-CVP11-10-E		
	15 m	JZSP-CVP01-15-E	JZSP-CVP11-15-E		
	20 m	JZSP-CVP01-20-E	JZSP-CVP11-20-E		
	3 m	JZSP-CVP02-03-E	JZSP-CVP12-03-E		
	5 m	JZSP-CVP02-05-E	JZSP-CVP12-05-E		
	10 m	JZSP-CVP02-10-E	JZSP-CVP12-10-E		
	15 m	JZSP-CVP02-15-E	JZSP-CVP12-15-E		
	20 m	JZSP-CVP02-20-E	JZSP-CVP12-20-E		
Encoder Cable with Connectors (For Absolute Encoder, with a Battery Case)	3 m	JZSP-CVP06-03-E	JZSP-CVP26-03-E	 <p>SERVOPACK End L Encoder End</p> <p>Connector (Crimped) (Molex Japan Co., Ltd.) CM10-SP10S-□-D (DDK Ltd.)</p>	(2)
	5 m	JZSP-CVP06-05-E	JZSP-CVP26-05-E		
	10 m	JZSP-CVP06-10-E	JZSP-CVP26-10-E		
	15 m	JZSP-CVP06-15-E	JZSP-CVP26-15-E		
	20 m	JZSP-CVP06-20-E	JZSP-CVP26-20-E		
	3 m	JZSP-CVP07-03-E	JZSP-CVP27-03-E		
	5 m	JZSP-CVP07-05-E	JZSP-CVP27-05-E		
	10 m	JZSP-CVP07-10-E	JZSP-CVP27-10-E		
	15 m	JZSP-CVP07-15-E	JZSP-CVP27-15-E		
	20 m	JZSP-CVP07-20-E	JZSP-CVP27-20-E		
SERVOPACK-end Connector Kit		JZSP-CMP9-1-E		<p>Soldered</p>  <p>(Molex Japan Co., Ltd.)</p>	(3)
Encoder-end Connectors for Protective Structure IP67 Straight Plug		JZSP-CVP9-1-E	<p>Connector Specifications</p> <p>Plug: CM10-SP10S-M-D</p> <p>Electrical Contact: (Crimped)*2</p> <p>CM10-#22SC(C4)-100</p> <p>Applicable Cable Diameter: 6.0 dia. to 9.0 dia.)</p>	 + Electrical Contact	-
		JZSP-CVP9-3-E	<p>Connector Specifications</p> <p>Plug: CM10-SP10S-M-D</p> <p>Electrical Contact: (Soldered)</p> <p>CM10-#22SC(S1)-100</p> <p>Applicable Cable Diameter: 6.0 dia. to 9.0 dia.)</p>		
Encoder-end Connectors for Protective Structure IP67 L-shaped Plug		JZSP-CVP9-2-E	<p>Connector Specifications</p> <p>Plug: CM10-AP10S-M-D</p> <p>Electrical Contact: (Crimped)*2</p> <p>CM10-#22SC(C4)-100</p> <p>Applicable Cable Diameter: 6.0 dia. to 9.0 dia.)</p>	 + Electrical Contact	-
		JZSP-CVP9-4-E	<p>Connector Specifications</p> <p>Plug: CM10-AP10S-M-D</p> <p>Electrical Contact: (Soldered)</p> <p>CM10-#22SC(S1)-100</p> <p>Applicable Cable Diameter: 6.0 dia. to 9.0 dia.)</p>		
Cables	3 m	JZSP-CMP09-03-E	JZSP-CSP39-03-E		(4)
	5 m	JZSP-CMP09-05-E	JZSP-CSP39-05-E		
	10 m	JZSP-CMP09-10-E	JZSP-CSP39-10-E		
	15 m	JZSP-CMP09-15-E	JZSP-CSP39-15-E		
	20 m	JZSP-CMP09-20-E	JZSP-CSP39-20-E		

*1: Use flexible cables for movable sections such as robot arms.

*2: A crimp tool (357J-52667T) is required.

Selecting Cables

(1) Wiring Specifications for Cable with Connectors (For incremental encoder)

· Standard Type

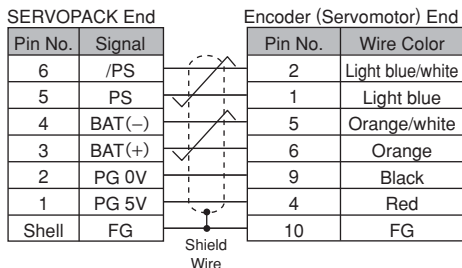

· Flexible Type

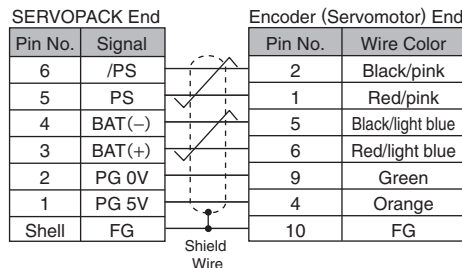

(2) Wiring Specifications for Cable with Connectors (For absolute encoder, with a battery case)

· Standard Type

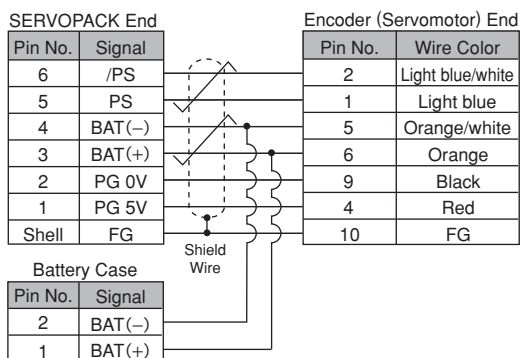

· Flexible Type

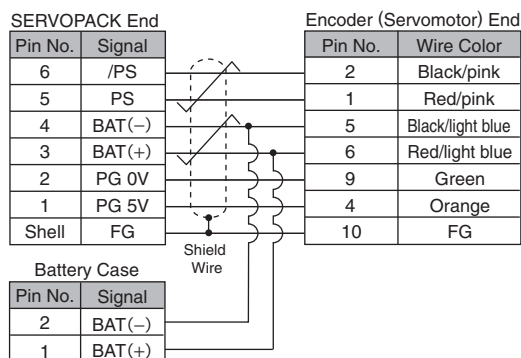

(3) SERVOPACK-end Connector Kit Specifications

Items	Specifications
Order No.	JZSP-CMP9-1-E
Manufacturer	Molex Japan Co., Ltd.
Connector Model (For standard)	55100-0670 (soldered)
External Dimensions (Units: mm)	

Note: The mating connector model on SERVOPACK: 54280-800
The mating connector model on servomotor: 55102-0600

(4) Cable Specifications

Items	Standard Type	Flexible Type
Order No.*	JZSP-CMP09-□□-E	JZSP-CSP39-□□-E
Cable Length	20 m max.	
Specifications	UL20276 (Rating temperature: 80°C) AWG22×2C+AWG24×2P AWG22 (0.33 mm ²) Outer diameter of insulating sheath: 1.15 dia. AWG24 (0.20 mm ²) Outer diameter of insulating sheath: 1.09 dia.	UL20276 (Rating temperature: 80°C) AWG22×2C+AWG24×2P AWG22 (0.33 mm ²) Outer diameter of insulating sheath: 1.35 dia. AWG24 (0.20 mm ²) Outer diameter of insulating sheath: 1.21 dia.
Finished Dimensions	6.5 dia.	6.8 dia.
Internal Configuration and Lead Color		
Yaskawa Standards Specifications (Standard Length)	Cable length: 5 m, 10 m, 15 m, 20 m	

*: Specify the cable length in □□ of order no.
Example: JZSP-CMP09-05-E (5 m)

Selecting Cables

Encoder Cables (For extending from 30 to 50 m)

Name	Length	Order No.	Specifications	Details
① Encoder-end Cables (For incremental and absolute encoder)	0.3 m	JZSP-CVP01-E	<p>SERVOPACK End 0.3 m Encoder End Plug Connector (Crimped) (Molex Japan Co., Ltd.) CM10-SP10S-□-D (DDK Ltd.)</p>	(1)
		JZSP-CVP02-E	<p>SERVOPACK End 0.3 m Encoder End Plug Connector (Crimped) (Molex Japan Co., Ltd.) CM10-AP10S-□-D (DDK Ltd.)</p>	
② Cable with Connectors (For incremental and absolute encoder)	30 m	JZSP-UCMP00-30-E	<p>SERVOPACK End L Encoder End Connector (Crimped) (Molex Japan Co., Ltd.) Socket Connector (Soldered) (Molex Japan Co., Ltd.)</p>	(2)
	40 m	JZSP-UCMP00-40-E		
	50 m	JZSP-UCMP00-50-E		
③ Cable with a Battery Case (For absolute encoder)	0.3 m	JZSP-CSP12-E*	<p>SERVOPACK End 0.3 m Encoder End Connector (Crimped) (Molex Japan Co., Ltd.) Socket Connector (Soldered) (Molex Japan Co., Ltd.) Battery Case (Battery attached)</p>	(3)
④ Relay Cables	30 m	JZSP-CMP19-30-E		(4)
	40 m	JZSP-CMP19-40-E		
	50 m	JZSP-CMP19-50-E		

*: When using an incremental encoder or using an absolute encoder with a battery connected to the host controller, no battery case is required.

(1) Wiring Specifications for Encoder-end Cable (For incremental and absolute encoder)

SERVOPACK End		Encoder (Servomotor) End	
Pin No.	Signal	Pin No.	Wire Color
6	/PS	2	Light blue/white
5	PS	1	Light blue
4	BAT(-)	5	Orange/white
3	BAT(+)	6	Orange
2	PG 0V	9	Black
1	PG 5V	4	Red
Shell	FG	10	FG

Shield Wire

Note: The signals BAT(+) and BAT(-) are used when using an absolute encoder.

(2) Wiring Specifications for Cable with Connectors (For incremental and absolute encoder)

SERVOPACK End		Encoder (Servomotor) End	
Pin No.	Signal	Pin No.	Wire Color
6	/PS	6	Light blue/white
5	PS	5	Light blue
4	BAT(-)	4	Orange/white
3	BAT(+)	3	Orange
2	PG 0V	2	Black
1	PG 5V	1	Red
Shell	FG	Shell	FG

Shield Wire

(3) Wiring Specifications for Cable with a Battery Case (For absolute encoder)

SERVOPACK End		Encoder (Servomotor) End	
Pin No.	Signal	Pin No.	Wire Color
6	/PS	6	Light blue/white
5	PS	5	Light blue
4	BAT(-)	4	Orange/white
3	BAT(+)	3	Orange
2	PG 0V	2	Black
1	PG 5V	1	Red
Shell	FG	Shell	FG

Shield Wire

Battery Case	
Pin No.	Signal
2	BAT(-)
1	BAT(+)

(4) Relay Encoder Cable Specifications

Item	Standard Type
Order No.*	JZSP-CMP19-□□-E
Cable Length	50 m max.
Specifications	UL20276 (Rating temperature: 80°C) AWG16×2C+AWG26×2P AWG16 (1.31 mm ²) Outer diameter of insulating sheath: 2.0 dia. mm AWG26 (0.13 mm ²) Outer diameter of insulating sheath: 0.91 dia. mm
Finished Dimensions	6.8 dia.
Internal Configuration and Lead Colors	<p>Orange Orange /white Red Light Blue Light Blue /white</p>
Yaskawa Standard Specifications (Standard Length)	Cable length: 30 m, 40 m, 50 m

*: Specify the cable length in □□ of order no.
Example: JZSP-CMP19-30-E (30 m)



Rotary Servomotor General Instructions

Precautions on Servomotor Installation

Servomotors can be installed either horizontally or vertically.

The service life of the servomotor will be shortened or unexpected problems will occur if the servomotor is installed incorrectly or in an inappropriate location. Always observe the following installation instructions.

CAUTION

Do not connect the servomotor directly to a commercial power line. This will damage the servomotor.

The servomotor cannot operate without the proper SERVOPACK.

(1) Installation Environment

Items	Condition
Ambient Temperature	0 to 40°C (no freezing)
Ambient Humidity	20% to 80%RH (no condensation)
Installation Site	<ul style="list-style-type: none"> • Free of corrosive or explosive gases. • Well-ventilated and free of dust and moisture. • Facilitates inspection and cleaning. • Elevation :1,000 m max. • Free of high magnetic field
Storage Environment	Store the servomotor in the following environment if it is stored with the power cable disconnected. Ambient temperature during storage: -20 to +60°C (no freezing) Ambient humidity during storage: 20% to 80%RH (no condensation)

(2) Enclosure

The servomotor enclosure* is described table as follows.

Model	Without Gears	With Gears
SGMAV, SGMJV	IP65	IP55
SGMPS	IP55 IP67 (optional)	IP55
SGMGV	IP67	-
SGMSV	IP67 (SGMSV-70 servomotor only: IP22)	-

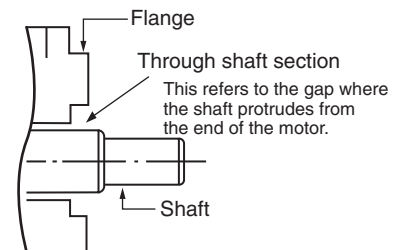

*: Except through shaft section. The enclosure specification can be satisfied only when using a specified cable.

- Do not use servomotors in a location that is subject to oil. If the servomotor is used in a location that is subject to water or oil mist, order a servomotor with an oil seal to seal the through shaft section.

Precautions on Using Servomotor with Oil Seal:

- Put the oil surface under the oil seal lip.
- Use an oil seal in favorably lubricated condition.
- When using a servomotor with its shaft upward direction, be sure that oil will not stay in the oil seal lips.

(3) Orientation

- Servomotors can be installed either horizontally or vertically. When installing servomotors vertically, make cable traps to keep out water. When mounting servomotors with the shaft up, take measures with the connected machine to prevent oil from getting into the servomotors through gear boxes etc.

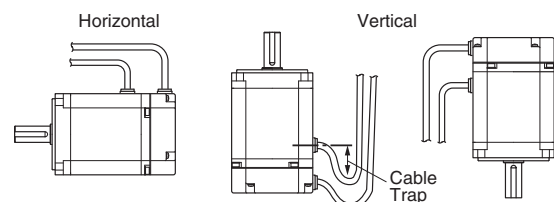

(4) Alignment

Align the shaft of the servomotor with the shaft of the equipment, and then couple the shafts.

IMPORTANT

- 1 Install the servomotor so that alignment accuracy falls within the following range. Vibration that will damage the bearings and encoders if the shafts are not properly aligned.

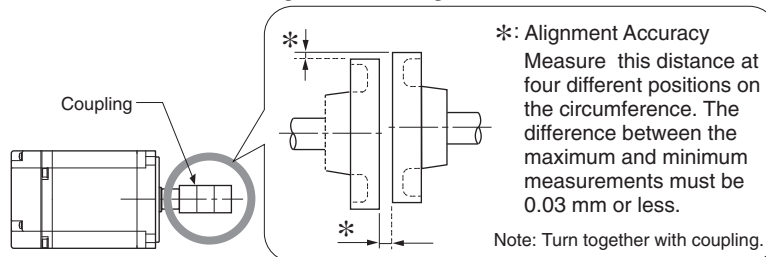

- 2 Do not allow any direct impact to the shafts when installing the couplings. Do not hit the area near encoders with a hammer etc., as impacts may damage the encoders.

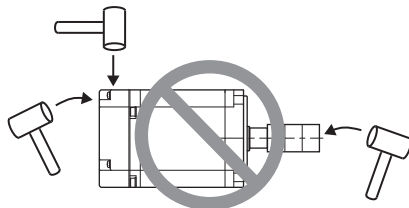

- 3 Before installation, thoroughly remove the anticorrosive paint from the end of the motor shaft. Only after removing the paint can servomotors be installed on the machines.

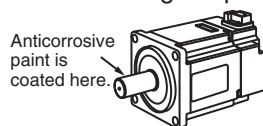

(5) Cable Stress

- Make sure there is no bending or tension on the cables themselves, the connections, or the cable lead inlets. Be especially careful to wire encoder cables so that they are not subject to stress because the core wires of encoder cables and main circuit cables are very thin at only 0.2 to 0.3 mm².

(6) Connectors

Observe the following precautions:

- When the connectors are connected to the motor, be sure to connect the end of motor main circuit cables before connecting the encoder cable's end. If the encoder cable's end is connected, the encoder may break because of the voltage differences between FG.
- Make sure there is no foreign matters such as dust and metal chips in the connector before connecting.
- Do not apply shock to resin connectors. Otherwise, they may be damaged.
- Make sure of the pin arrangement.
- Be sure not to apply stress on the connector, when using flexible cables. The connector may be damaged by stress.
- When handling a servomotor with its cables connected, hold the servomotor or the connectors and cables will be damaged.
- Fix the cable connector to SGMJV, SGMAV, SGMPS-01/-02/-04 or SGMGV-03/-05 servomotors with screws. Refer to "Cable connections to SGMJV, SGMAV and SGMPS servomotors" or "Cable connections to SGMGV-03/-05 servomotors." Make sure that the connector is securely fixed with screws.
- If connectors are not connected properly, the protective structure specifications may not be satisfied.

Cable Connections to SGMJV, SGMV and SGMPS Servomotors

Connect the main circuit cable and encoder cable to SGMJV, SGMV or SGMPS-01/-02/-04 servomotor in the following manner.

! CAUTION

Do not directly touch the connector pins provided with the servomotor. Particularly, the encoder may be damaged by static electricity, etc.

STEP1 Remove the protective tape and cap from the servomotor connector.

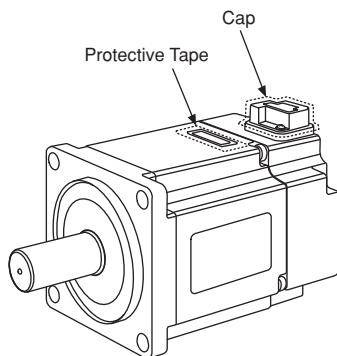

STEP2 Mount the cable connector on the servomotor and fix it with screws as shown in the figure below.

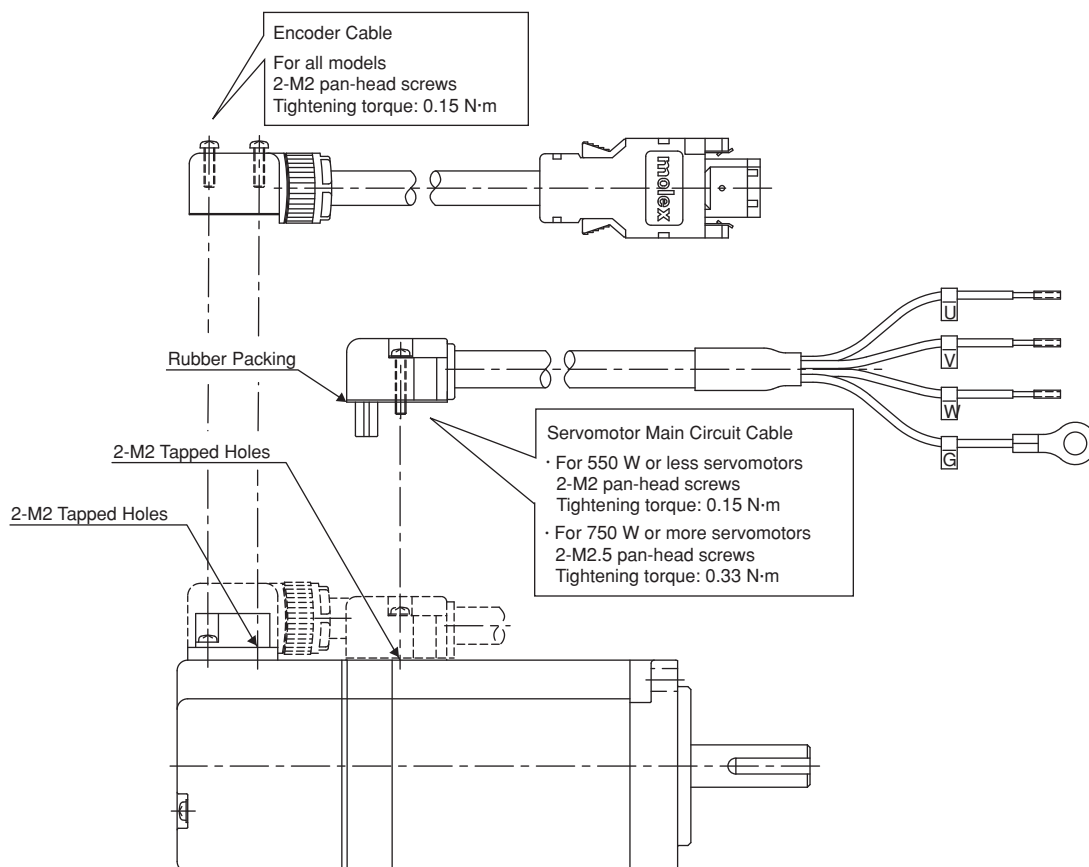

IMPORTANT

- First, connect the servomotor to the servomotor main circuit cable end.
 - Do not remove the rubber packing. Mount the connector so that the rubber packing is seated properly.
- If the rubber packing is not seated properly, the requirements for the protective structure specifications may not be met.

Cable Connections to SGMGV-03/-05 Servomotors

Connect the main circuit cable and encoder cable to SGMGV-03/-05 servomotor in the following manner.

! CAUTION

Do not directly touch the connector pins provided with the servomotor. Particularly, the encoder may be damaged by static electricity, etc.

STEP1 Remove the protective cap from the servomotor connector.

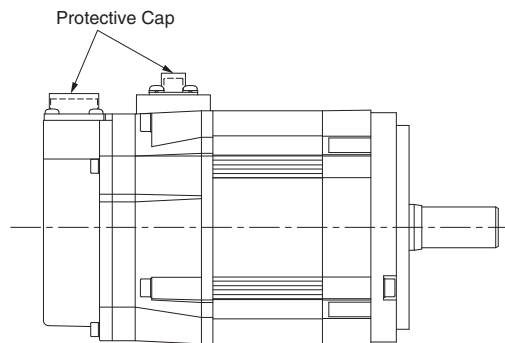

STEP2 Mount the cable connector on the servomotor and fix it with screws as shown in the figure below.

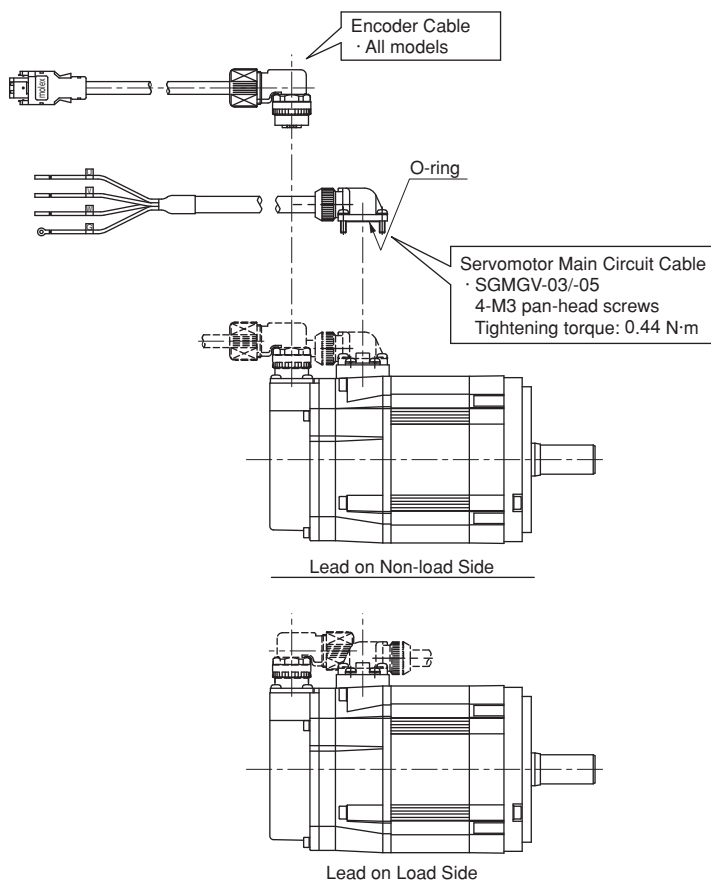

IMPORTANT

- First, connect the servomotor to the servomotor main circuit cable end.
- Do not remove the O-ring. Mount the connector so that the O-ring is seated properly. If the O-ring is not seated properly, the requirements for the protective structure specifications may not be met.

Mechanical Specifications

● Mechanical Tolerance T.I.R. (Total Indicator Reading)

The following figure shows tolerances for the servomotor's output shaft and installation area. For more details on tolerances, refer to the external dimensions of the individual servomotor.

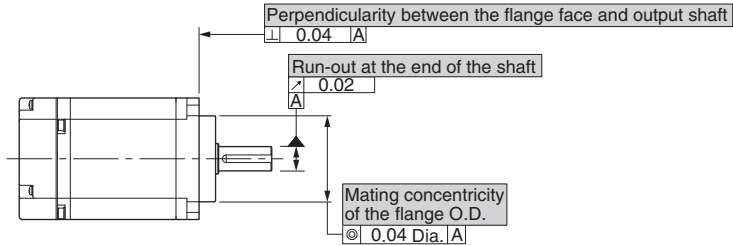

● Direction of Servomotor Rotation

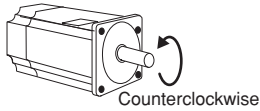

Positive rotation of the servomotor without a gear is counterclockwise when viewed from the load. Refer to *Ratings and Specifications* for each series regarding rotation direction of the servomotor with a gear. The direction of rotation can be reversed by changing the SERVOPACK parameters.

● Shock Resistance

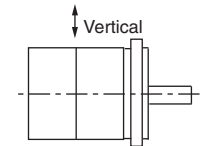

Impact Applied to the Servomotor

Mount the servomotor with the axis horizontal. The servomotor will withstand the following vertical impacts:

- Impact Acceleration: 490 m/s²
- Impact occurrences: 2

● Vibration Resistance

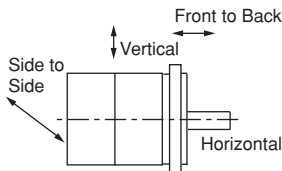

Impact Applied to the Servomotor

Mount the servomotor with the axis horizontal. The servomotor will withstand the following vibration acceleration in three directions: Vertical, side to side, and front to back.

Servomotor Model	Vibration Acceleration at Flange
SGMJV, SGMAV, SGMPS	49 m/s ²
SGMGV -03 to -44, SGMSV -10 to -50	49 m/s ² (Front to back direction: 24.5 m/s ²)
SGMGV -55 to -1E	24.5 m/s ²
SGMSV -70	14.7 m/s ²

IMPORTANT

The amount of vibration the servomotor endures will vary depending on the application. Check the vibration acceleration being applied to your servomotor for each application.

● Vibration Class

The vibration class for the servomotors at rated motor speed is V15.

(A vibration class of V15 indicates a total vibration amplitude of 15 μm maximum on the servomotor during rated rotation.)

Rotor Moment of Inertia

Small-capacity servomotors come in a medium inertia series "SGMJV servomotor," "SGMPS servomotor" and low inertia series "SGMAV servomotor." The rotor moment of inertia of SGMJV servomotor and SGMPS servomotor are twice as large as that of SGMAV. Select servomotors based on the specifications of your devices, such as load moment of inertia or machine rigidity.

- When the rotor moment of inertia is large:

Servomotors are capable of corresponding load changes. This has the benefit of reducing settling time and speed ripple. This should also improve control stability of machines with low rigidity.

- When mounting the servomotor with low rotor moment of inertia to devices with load moment of inertia:

Acceleration/deceleration torque increases and effective load ratio increases. Check the effective load ratio when you select motor capacity.

Servomotor Heating Conditions

The motor rated specifications are continuous allowable values at an ambient temperature of 40°C when servomotors are installed with heat sinks. When the motor is mounted on a small surface, the motor temperature may rise considerably because of the limited heat radiating abilities of the surface. See the following graph for the relation between heat sink size and derating (derating ratio).

IMPORTANT The actual temperature rise depends on how the heat sink (servomotor mounting section) is fixed on the installation surface, what material is used for the motor mounting section, and motor speed. Always check the actual motor temperature.

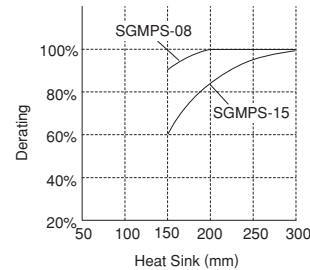
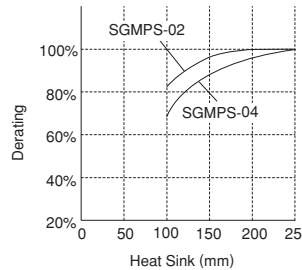
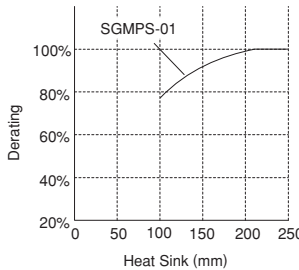
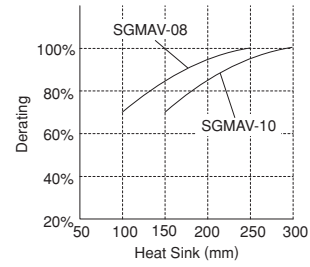
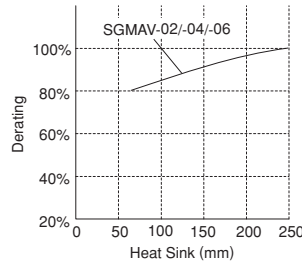
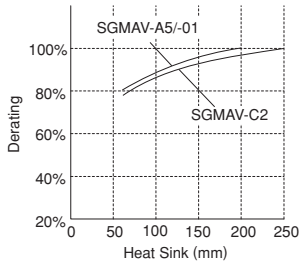
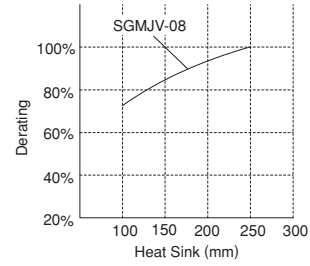
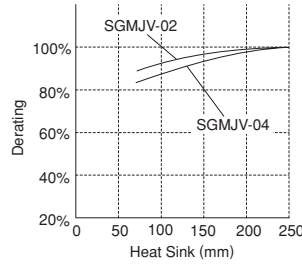
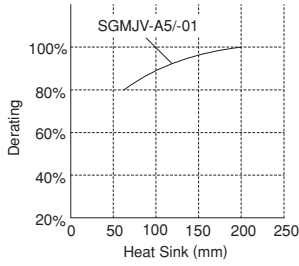

Holding Brake Delay Time

Holding brakes have motion delay time that varies depending on when the brake is open and when the brake is operating. The following table shows the brake delay time of each servomotor.

IMPORTANT

Make sure the holding brake delay time is correct for your servomotor.

- Example, switching the holding brakes on the DC side

Model	Voltage	Brake Open Time ms	Brake Operation Time ms	Model	Voltage	Brake Open Time ms	Brake Operation Time ms
SGMAV-A5 to -04	24 V	60	100	SGMGV-03 to -20	24 V, 90 V	100	80
SGMAV-06 to -10		80	100	SGMGV-30,-44		170	100(24 V),80(90 V)
SGMJV-A5 to -04	24 V	60	100	SGMGV-55,-75,-1A		170	80
SGMJV-08		80	100	SGMGV-1E		250	80
SGMPS-01, -08	24 V	20	100	SGMSV-10 to -25		170	80
SGMPS-02, -04, -15		40	100	SGMSV-30 to -50		100	80

Terms for Servomotors with Gears

(1) Terminology for Servomotors with Low-backlash Gears

Item	Measurement Method/Definition	Typical Value
Rated Torque (N · m)	The rated output torque of the motor is the gear input torque. The rated torque is this value multiplied by the inverse of the gear ratio and efficiency.	—
Lost Motion (arc-min)*	Angular difference in a screw with a $\pm 5\%$ rated torque load. (Maximum value at any four positions during output.)	3 max.
Torsion Rigidity (arc-min)*	Highest torsion angle value on one side with a \pm rated torque load.	10 max.
Angular Transmission Error Accuracy (arc-min)	Difference in absolute accuracy for one rotation under load and no-load conditions during output.	6 max.

*: See the following graph for lost motion and torsion rigidity.

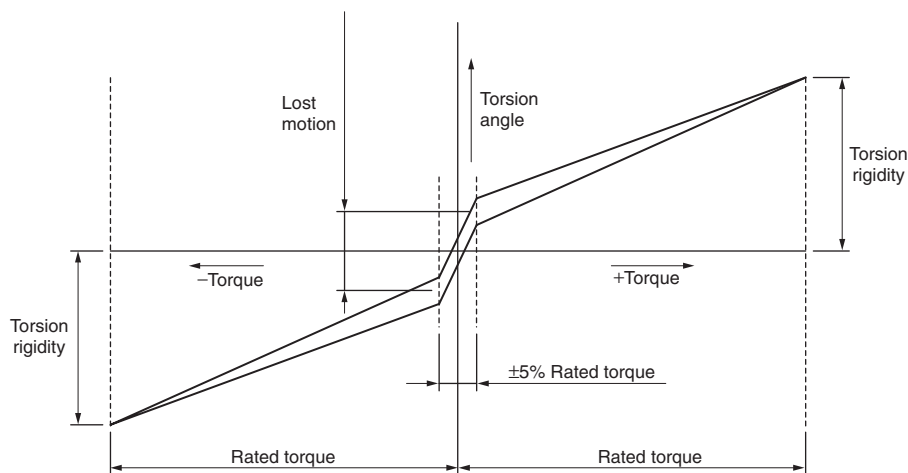

(2) Noise Data

The following noise data for a servomotor with a gear is for reference only. The data may vary slightly depending on the capacity and gear ratio of the servomotor.

Measurement Conditions

- Scale A: 50 cm
- Ground Noise: 28 dB

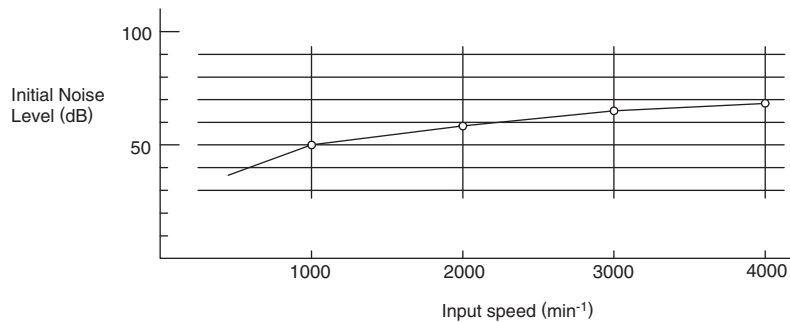

(3) Efficiency

The output torque and motor speed produce the following trends in efficiency. The values in the tables, Ratings and Specifications of SGM□□ Servomotors with Gears, are at the rated motor torque and rated motor speed.

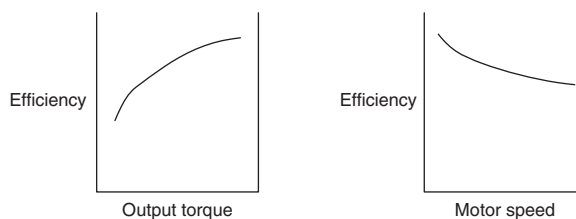

Cables

● Standard Cables

Standard servomotor main circuit cables, encoder cables, and relay cables cannot be used in cases where high flexibility is needed, as when the cables themselves move or are twisted or turned.

R15 min. is recommended for the bending radius of standard cables. Use flexible cables for flexible applications.

● Flexible Cables

(1) Life of Flexible Cable

The flexible cable supports 10,000,000 or more operations of bending life with the recommended bending radius $R = 90$ mm under the following test conditions.

● Conditions

- 1 Repeat moving one end of the cable forward and backward for 320 mm using the test equipment shown in the following figure.
- 2 Connect the lead wires in parallel, and count the number of cable return motion times until a lead wire is disconnected. Note that one reciprocation is counted as one test.

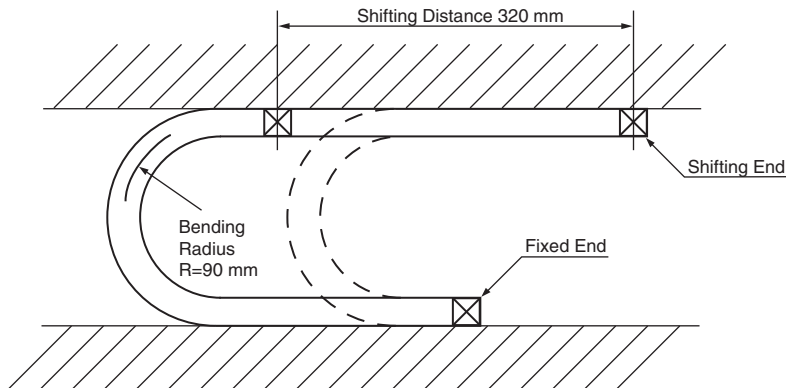

Notes: 1 The life of flexible cable differs largely depending on the amount of mechanical shocks, mounting to the cable, and fixing methods. The life of flexible cable is limited under the specified conditions.

2 The life of flexible cable indicates the number of bending times in which lead wires are electrically conducted and by which no cracks and damages that affects the performance of cable sheathing are caused. Disconnecting the shield wire is not taken into account.

(2) Wiring Precautions

Even if the recommended bending radius R is followed in the mechanical design, incorrect wiring may cause the early disconnection. Observe the following precautions when wiring.

(a) Cable twisting

Straighten the flexible cables wiring.

Twisted cables cause the early disconnection. Check the indication on the cable surface to make sure that the cable is not twisted.

(b) Fixing method

Do not fix the moving points of the flexible cable, or stress on the fixed points may cause early disconnection.

Fix the cable at the minimum number of points. Do not put stress on the servomotor-end and SERVOPACK-end connectors.

(c) Cable length

If the cable length is too long, it may result the cable sagging. If the cable length is too short, excessive tension on the fixed points will cause the early disconnection. Use a flexible cable with the optimum length.

(d) Interference between cables

Avoid interference between cables.

Interference limits the motion of flexible cable, which causes early disconnection. Keep enough distance between cables, or provide a partition when wiring.

Battery Case

● Battery Case (Model: JUSP-BA01-E)

Use this battery case if your battery case needs replacing due to damage etc.. This battery case cannot be used with an incremental encoder cable.

- IMPORTANT**
- 1 The battery case (JUSP-BA01-E) is not provided with a battery. A battery must be purchased separately.
 - 2 Install the battery case where the ambient temperature is between 0°C to 55°C.

Note: Cable and connector to connect encoder cable and battery case are not included.

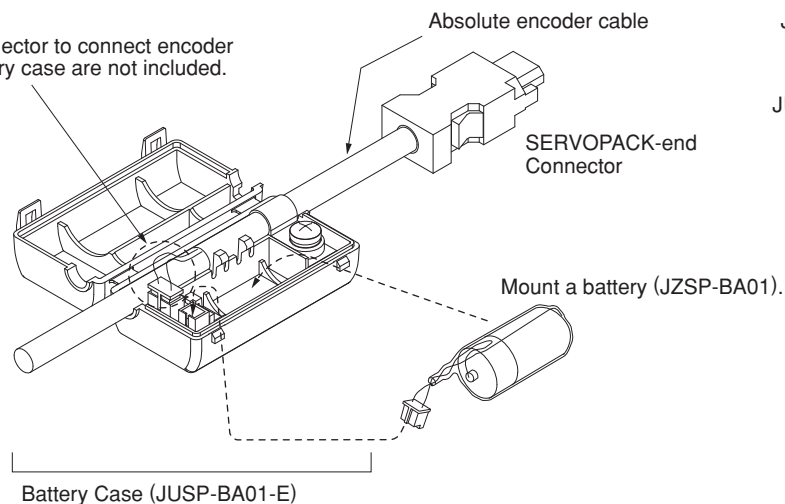

JZSP-CSP04-□□-E
 05-□□-E
 06-□□-E
 07-□□-E
 JZSP-CVP□6-□□-E
 □7-□□-E

(1) Mounting a Battery in a Battery Case

Prepare a lithium battery (JZSP-BA01) and mount in a battery case.

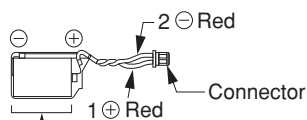

ER3 V Lithium Battery
 (3.6 V, 1000 mAh, manufactured by Toshiba Battery Co., Ltd.)

(2) Connecting a Battery to the Host Controller

Use a battery that meets the specifications of the host controller. Use an ER6VC3N (3.6 V, 2000 mAh, manufactured by Toshiba Battery Co., Ltd.) or equivalent battery.

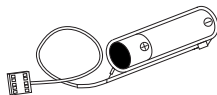

Direct Drive Servomotors

SGMCS

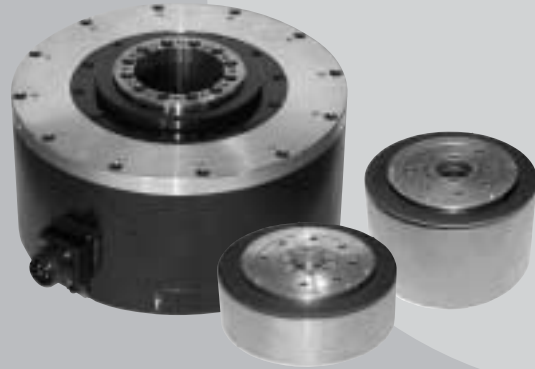

Model Designations

SGMCS - 02 B 3 C 1 1

Direct Drive Servomotor SGMCS

1st+2nd digits 3rd digit 4th digit 5th digit 6th digit 7th digit

1st+2nd digits Rated Torque

● Small-capacity

Code	Specifications
02	2.0 N·m
04	4.0 N·m
05	5.0 N·m
07	7.0 N·m
08	8.0 N·m
10	10 N·m
14	14 N·m
16	16 N·m
17	17 N·m
25	25 N·m
35	35 N·m

● Medium-capacity

Code	Specifications
45	45 N·m
80	80 N·m
1A	110 N·m
1E	150 N·m
2Z	200 N·m

3rd digit Motor Outer Diameter

Code	Specifications
B	135 dia. mm
C	175 dia. mm
D	230 dia. mm
E	290 dia. mm
M	280 dia. mm
N	360 dia. mm

4th digit Encoder Specifications

Code	Specifications
3	20-bit absolute (without multiturn data) (standard)
D	20-bit incremental (option)

5th digit Design Revision Order

Code	Specifications
A	Model of servomotor outer diameter code M, N
B	Model of servomotor outer diameter code E
C	Model of servomotor outer diameter code B, C, D

6th digit Flange Specifications

Code	Flange Specifications		Motor Outer Diameter Code (3rd digit)					
	Specifications	Mounted Side	B	C	D	E	M	N
1	C-face	Non-load side	○	○	○	○	-	-
		load end	-	-	-	-	○	○
3	C-face	Non-load side	-	-	-	-	○	○
4	C-face	Non-load side (with cable on side)	○	○	○	○	-	-

○ : Applicable Model

7th digit Option

Code	Specifications
1	Without options

Features

- Directly coupled to a load without a mechanical transmission such as a gear.
- Powerful and smooth operation throughout the speed range from low to high.
(Instantaneous peak torque: 6 to 600 N·m
maximum speed: 250 to 500 min⁻¹)
- High-resolution, 20-bit encoder for highly precise indexing.
- Easy wiring and piping with the hollow structure.

Application Examples

- Semiconductor equipment
- LCD manufacturing equipment
- Units for inspection and testing
- Electronic parts assembling machines
- IC handlers
- Inspection units for integrated circuits
- Automated machines
- Robots

Rated Torque / Peak Torque

● Small-capacity



Outer Diameter 135 mm, Inner Diameter 20 mm

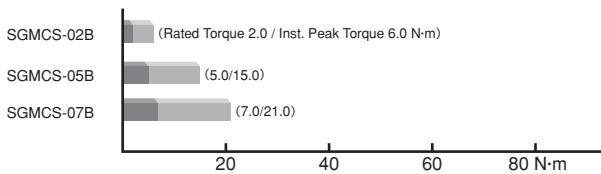

Outer Diameter 175 mm, Inner Diameter 35 mm

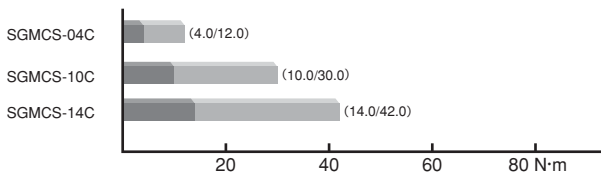

Outer Diameter 230 mm, Inner Diameter 60 mm

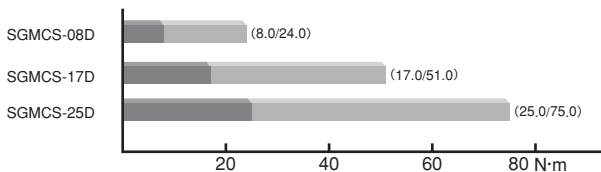

Outer Diameter 290 mm, Inner Diameter 75 mm

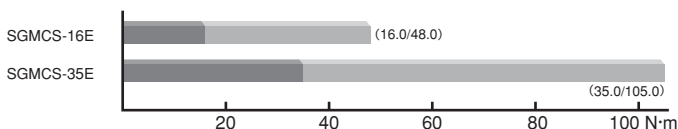

● Medium-capacity

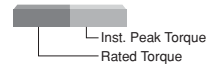

Outer Diameter 280 mm, Inner Diameter 75 mm

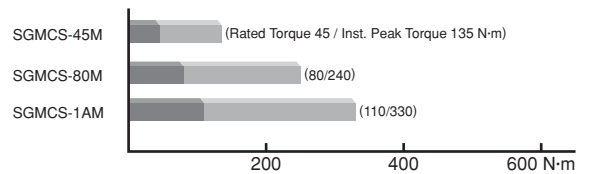

Outer Diameter 360 mm, Inner Diameter 118 mm

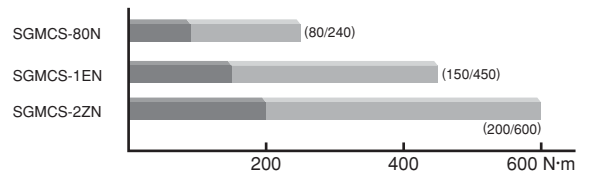

Ratings and Specifications

● Small-capacity Series

Time Rating: Continuous

Vibration Class: V15

Insulation Resistance: 500 VDC, 10 MΩ min.

Ambient Temperature: 0 to 40°C

Excitation: Permanent magnet

Mounting: Flange method

Thermal Class: A

Withstand Voltage: 1500 VAC for one minute

Enclosure: Totally enclosed, self-cooled, IP42 (except for gaps on the rotating section of the shaft)

Ambient Humidity: 20% to 80% (no condensation)

Drive Method: Direct drive

Rotation Direction: Counterclockwise (CCW) with forward run reference when viewed from the load side

Voltage		200 V										
Servomotor Model SGMCS-□□□□□		02B□C	05B□C	07B□C	04C□C	10C□C	14C□C	08D□C	17D□C	25D□C	16E□B	35E□B
Rated Output*1	W	42	105	147	84	209	293	168	356	393	335	550
Rated Torque*1, *2	N·m	2.0	5.0	7.0	4.0	10.0	14.0	8.0	17.0	25.0	16.0	35.0
Instantaneous Peak Torque*1	N·m	6.0	15.0	21.0	12.0	30.0	42.0	24.0	51.0	75.0	48.0	105
Stall Torque*1	N·m	2.05	5.15	7.32	4.09	10.1	14.2	8.23	17.4	25.4	16.5	35.6
Rated Current*1	Arms	1.8	1.7	1.4	2.2	2.2	2.8	1.9	2.5	2.6	3.3	3.5
Instantaneous Max. Current*1	Arms	5.4	5.1	4.1	7.0	7.0	8.3	5.6	7.5	8.0	9.4	10.0
Rated Speed*1	min ⁻¹	200			200			200		150	200	150
Max. Speed*1	min ⁻¹	500			500	400	300	500	350	250	500	250
Torque Constant	N·m/Arms	1.18	3.17	5.44	2.04	5.05	5.39	5.1	7.8	10.8	5.58	11.1
Rotor Moment of Inertia	×10 ⁻⁴ kg·m ²	28	51	77	77	140	220	285	510	750	930	1430
Rated Power Rate*1	kW/s	1.4	4.9	6.4	2.1	7.1	8.9	2.2	5.7	8.3	2.75	8.57
Rated Angular Acceleration*1	rad/s ²	710	980	910	520	710	640	280	330	330	170	240
Absolute Accuracy	second	±15			±15			±15		±15		
Repeatability	second	±1.3			±1.3			±1.3		±1.3		
Applicable SERVOPACK	SGDV-□□□□□	2R8A			2R8A			2R8A		5R5A		

*1: These items and torque-motor speed characteristics quoted in combination with an SGDV SERVOPACK are at an armature winding temperature of 100°C. Other values quoted at 20°C.

*2: Rated torques are continuous allowable torque values at 40°C with a steel heat sink attached.

Heat sink: SGMCS-□□B : 350 mm × 350 mm × 12 mm SGMCS-□□C : 450 mm × 450 mm × 12 mm
 SGMCS-□□D : 550 mm × 550 mm × 12 mm SGMCS-□□E : 650 mm × 650 mm × 12 mm

Notes: 1 SGMCS servomotor with holding brake is not available.

2 For the bearings used in SGMCS servomotors, loss varies according to the bearing temperature. At low temperatures, the amount of heat loss will be large.

● Small-capacity Series: Torque-Motor Speed Characteristics

Ⓐ : Continuous Duty Zone Ⓑ : Intermittent Duty Zone^(Note2)

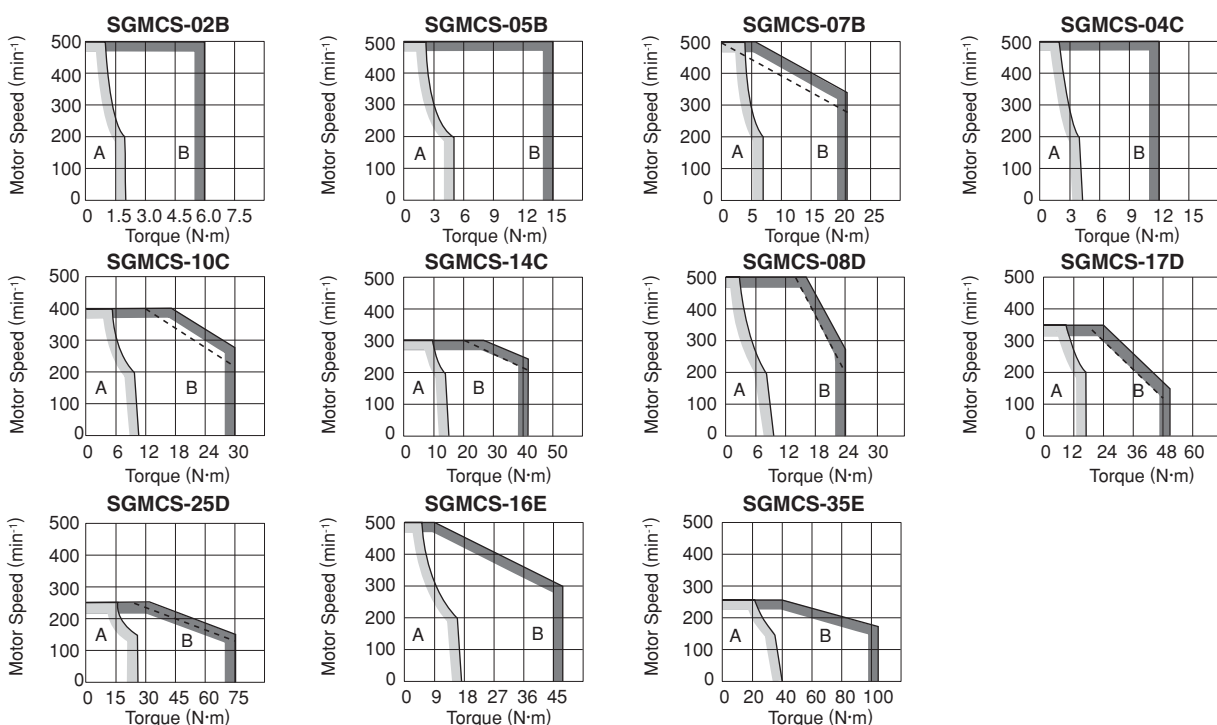

Notes: 1 The solid, dotted lines of the intermittent duty zone indicate the characteristics when a servomotor runs with the following combinations:

- The solid line: With a three-phase 200 V SERVOPACK
- The dotted line: With a single-phase 100 V SERVOPACK

2 When the effective torque during intermittent duty is within the rated torque, the servomotor can be used within the intermittent duty zone.

3 When the main circuit cable length exceeds 20 m, note that the intermittent duty zone of the *Torque-Motor Speed Characteristics* will shrink as the line-to-line voltage drops.

Ratings and Specifications

● Medium-capacity Series

Time Rating: Continuous

Vibration Class: V15

Insulation Resistance: 500 VDC, 10 MΩ min.

Ambient Temperature: 0 to 40°C

Excitation: Permanent magnet

Mounting: Flange method

Thermal Class: F

Withstand Voltage: 1500 VAC for one minute

Enclosure: Totally enclosed, self-cooled, IP44
(except for shaft opening)

Ambient Humidity: 20% to 80% (no condensation)

Drive Method: Direct drive

Rotation Direction: Counterclockwise (CCW) with forward run reference
when viewed from the load side

Voltage		200 V					
Servomotor Model SGMCS-□□□□		45M□A	80M□A	1AM□A	80N□A	1EN□A	2ZN□A
Rated Output*1	W	707	1260	1730	1260	2360	3140
Rated Torque*1, *2	N·m	45	80	110	80	150	200
Instantaneous Peak Torque*1	N·m	135	240	330	240	450	600
Stall Torque*1	N·m	45	80	110	80	150	200
Rated Current*1	Arms	5.80	9.74	13.4	9.35	17.4	18.9
Instantaneous Max. Current*1	Arms	17	28	42	28	56	56
Rated Speed*1	min ⁻¹	150					
Max. Speed*1	min ⁻¹	300			250		
Torque Constant	N·m/Arms	8.39	8.91	8.45	9.08	9.05	11.5
Rotor Moment of Inertia	×10 ⁻⁴ kg·m ²	388	627	865	1360	2470	3060
Rated Power Rate*1	kW/s	52.2	102	140	47.1	91.1	131
Rated Angular Acceleration*1	rad/s ²	1160	1280	1270	588	607	654
Applicable SERVOPACK	SGDV-□□□□	7R6A	120A	180A	120A	200A	200A

*1: These items and torque-motor speed characteristics quoted in combination with an SGD V SERVOPACK are at an armature winding temperature of 20°C.

*2: Rated torques are continuous allowable torque values at 40°C with a steel heat sink attached.
Heat sink: 750 mm × 750 mm × 45 mm

Notes: 1 SGMCS servomotor with holding brake is not available.

2 For the bearings used in SGMCS servomotors, loss varies according to the bearing temperature. At low temperatures, the amount of heat loss will be large.

● Medium-capacity Series: Torque-Motor Speed Characteristics

A : Continuous Duty Zone **B** : Intermittent Duty Zone^(Note1)

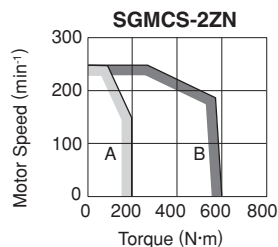
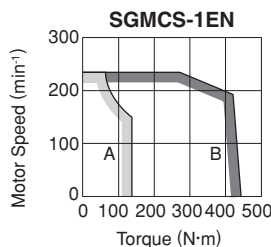
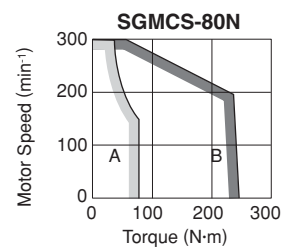
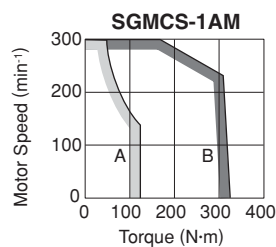
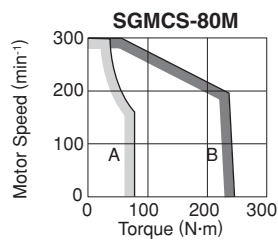
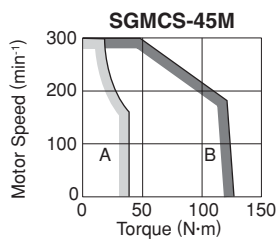

Notes: 1 When the effective torque during intermittent duty is within the rated torque, the servomotor can be used within the intermittent duty zone.

2 When the main circuit cable length exceeds 20 m, note that the intermittent duty zone of the *Torque-Motor Speed Characteristics* will shrink as the line-to-line voltage drops.

Ratings and Specifications

● Allowable Load Moment of Inertia at the Motor Shaft

Servomotor Model		Rated Torque N·m	Allowable Load Moment of Inertia (Rotor Moment of Inertia Ratio)
SGMCS-	02B□C, 05B□C, 07B□C, 04C□C	2.0, 5.0, 7.0, 4.0	10 times
	10C□C	10.0	5 times
	14C□C, 08D□C, 17D□C, 25D□C, 16E□B, 35E□B	14.0, 8.0, 17.0, 25.0, 16.0, 35.0	3 times
	45M□A, 80M□A, 1AM□A, 80N□A, 1EN□A, 2ZN□A	45, 80, 110, 150, 200	3 times

● Load Moment of Inertia

The larger the load moment of inertia, the worse the movement response.

The allowable load moment of inertia (J_L) depends on the motor capacity, as shown above. This value is provided strictly as a guideline and results may vary depending on servomotor drive conditions.

Use the AC servo drive capacity selection program SigmaJunmaSize+ to check the operation conditions.

The program can be downloaded for free from our web site (<http://www.e-mechatronics.com/>) .

An overvoltage alarm (A.400) is likely to occur during deceleration if the load moment of inertia exceeds the allowable load moment of inertia. SERVOPACKs with a built-in regenerative resistor may generate a regenerative overload alarm (A.320). Take one of the following steps if this occurs.

- Reduce the torque limit.
- Reduce the deceleration rate.
- Reduce the maximum speed.
- Install an external regenerative resistor if the alarm cannot be cleared using the steps above. Refer to *Regenerative Resistors* on page 360.

Mechanical Specifications

● Allowable Loads

The loads applied while a servomotor is running are roughly classified in the following patterns. Design the machine so that the thrust load and moment load will not exceed the values in the table.

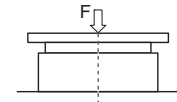

Where F is external force,
Thrust load: $F_a = F + \text{Load mass}$
Moment load: $M = 0$

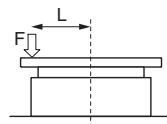

Where F is external force,
Thrust load: $F_a = F + \text{Load mass}$
Moment load: $M = F \times L$

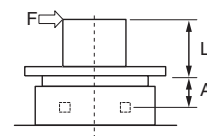

Where F is external force,
Thrust load: $F_a = \text{Load mass}$
Moment load: $M = F \times (L + A)$
(See the table below for the dimension A of each servomotor model.)

Servomotor Model SGMCS-□	02B	05B	07B	04C	10C	14C	08D	17D	25D	16E	35E	45M	80M	1AM	80N	1EN	2ZN
Dimension A mm	0			0			0			0		33		37.5			
Allowable Thrust Load (F_a) N	1500			3300			4000			11000		9000		16000			
Allowable Moment Load (M) N·m	40	50	64	70	75	90	93	103	135	250	320	180		350			

Note: SGMCS-02B to -35E servomotors, set dimensions A to 0 (zero).

● Mechanical Tolerance

The following table shows tolerances for the servomotor's output shaft and installation area. See the dimensional drawing of the individual servomotor for more details on tolerances.

(1) Small-capacity Series

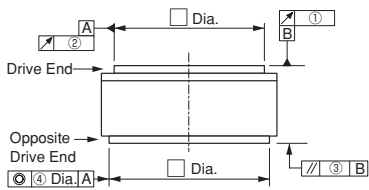

Tolerance T.I.R. (Total Indicator Reading) Units: mm	Servomotor Model SGMCS-										
	02B	05B	07B	04C	10C	14C	08D	17D	25D	16E	35E
① Run-out of the Surface of the Shaft	0.02		0.02		0.02		0.02		0.02		0.02
② Run-out at the End of the Shaft	0.04		0.04		0.04		0.04		0.04		0.04
③ Perpendicularity between the Flange Face and Output Shaft	0.07		0.07		0.07		0.08		0.08		0.08
④ Coaxiality of Output Axis and Mounting Socket Joint	0.07		0.07		0.07		0.08		0.08		0.08

(2) Medium-capacity Series

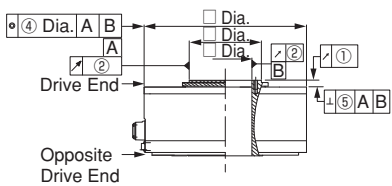

Tolerance T.I.R. (Total Indicator Reading) Units: mm	Servomotor Model SGMCS-					
	45M	80M	1AM	80N	1EN	2ZN
① Run-out of the Surface of the Shaft	0.02		0.02			
② Run-out at the End of the Shaft	0.04		0.04			
③ Perpendicularity between the Flange Face and Output Shaft	-		-			
④ Coaxiality of Output Axis and Mounting Socket Joint	0.08		0.08			
⑤ Right angle between Flange Face and Output Shaft	0.08		0.08			

● Direction of Rotation

Positive rotation of the servomotor is counterclockwise when viewed from the load.

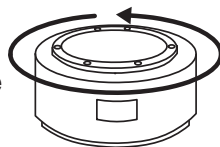

● Impact Resistance

Mount the servomotor with the axis horizontal. The servomotor will withstand the following vertical impacts:

- Impact Acceleration: 490 m/s²
- Number of Impacts: 2

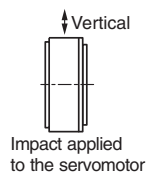

● Vibration Resistance

Mount the servomotor with the axis horizontal. The servomotor will withstand the following vibration acceleration in three directions: Vertical, side to side, and front to back.

Servomotor Type	Vibration Acceleration at Flange
Small-capacity Series	49 m/s ²
Medium-capacity Series	24.5 m/s ²

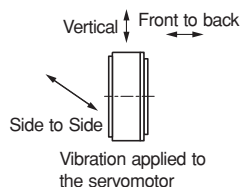

● Vibration Class

The vibration class at rated motor speed is V15. (A vibration class of V15 indicates a total vibration amplitude of 15 μm maximum on the servomotor during rated rotation.)

● Enclosure

Servomotor Type	Enclosure
Small-capacity Series	IP42 (except for gaps on the rotating section of the shaft)
Medium-capacity Series	IP44

External Dimensions Units: mm

● Small-capacity Series

(1) Rated Torque 2.0 to 7.0 N·m (Outer Diameter 135 mm, Inner Diameter 20 mm)

• Applicable Flange: 1

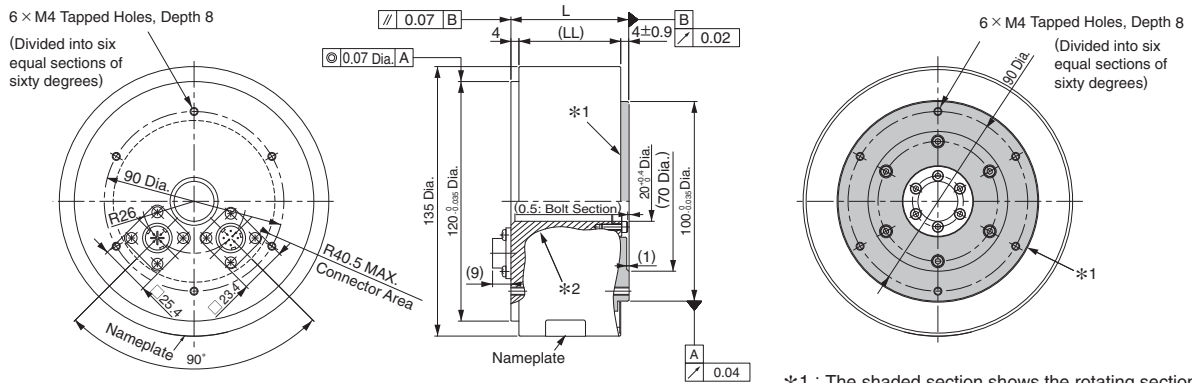

Model SGMCS-	L	(LL)	Approx. Mass kg
02B□C11	59	51	4.8
05B□C11	88	80	5.8
07B□C11	128	120	8.2

• Applicable Flange: 4

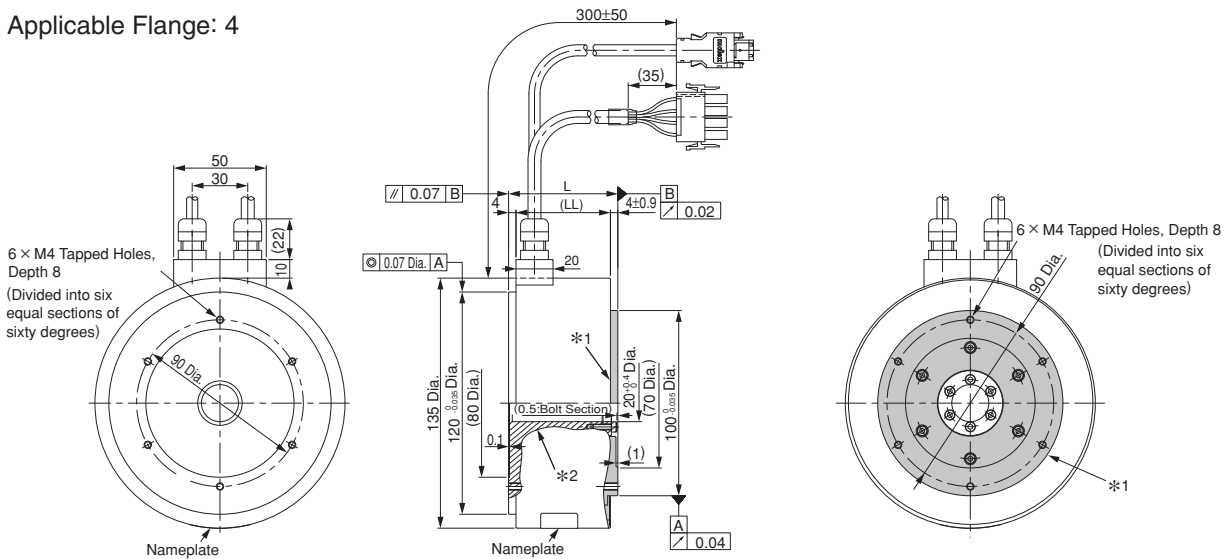

Model SGMCS-	L	(LL)	Approx. Mass kg
02B□C41	59	51	4.8
05B□C41	88	80	5.8
07B□C41	128	120	8.2

● Servomotor Connector for Small-capacity Series Servomotors (Applicable Flange: 1)

Servomotor-end Connector Specifications

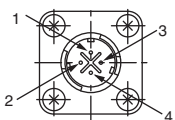

Model: JN1AS04MK2
 Manufacturer: Japan Aviation Electronics Industry, Ltd.
 Applicable plug: JN1DS04FK1
 (Provided by the customer.)

1	Phase U	Red
2	Phase V	White
3	Phase W	Blue
4	FG (Frame ground)	Green (yellow)

Encoder-end Connector Specifications

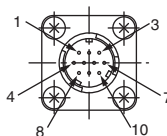

Model: JN1AS10ML1
 Manufacturer: Japan Aviation Electronics Industry, Ltd.
 Applicable plug: JN1DS10SL1
 (Provided by the customer.)

1	PS	Light blue	6	-	-
2	/PS	Light blue/ white	7	FG (Frame ground)	Shield
3	-	-	8	-	-
4	PG5V	Red	9	PG0V	Black
5	-	-	10	-	-

External Dimensions Units: mm

(2) Rated Torque 4.0 to 14.0 N·m (Outer Diameter 175 mm, Inner Diameter 35 mm)

• Applicable Flange: 1

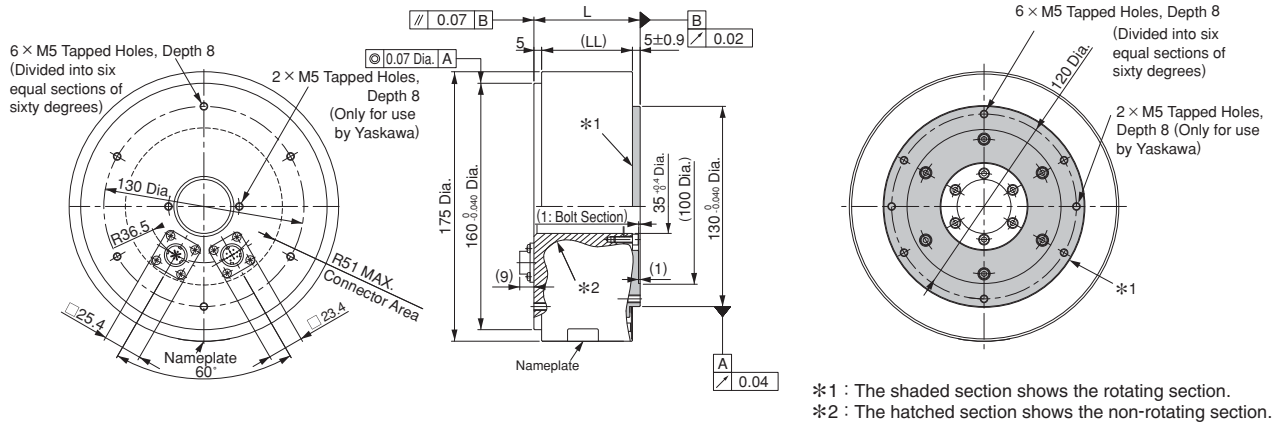

Model SGMCS-	L	(LL)	Approx. Mass kg
04C□C11	69	59	7.2
10C□C11	90	80	10.2
14C□C11	130	120	14.2

• Applicable Flange: 4

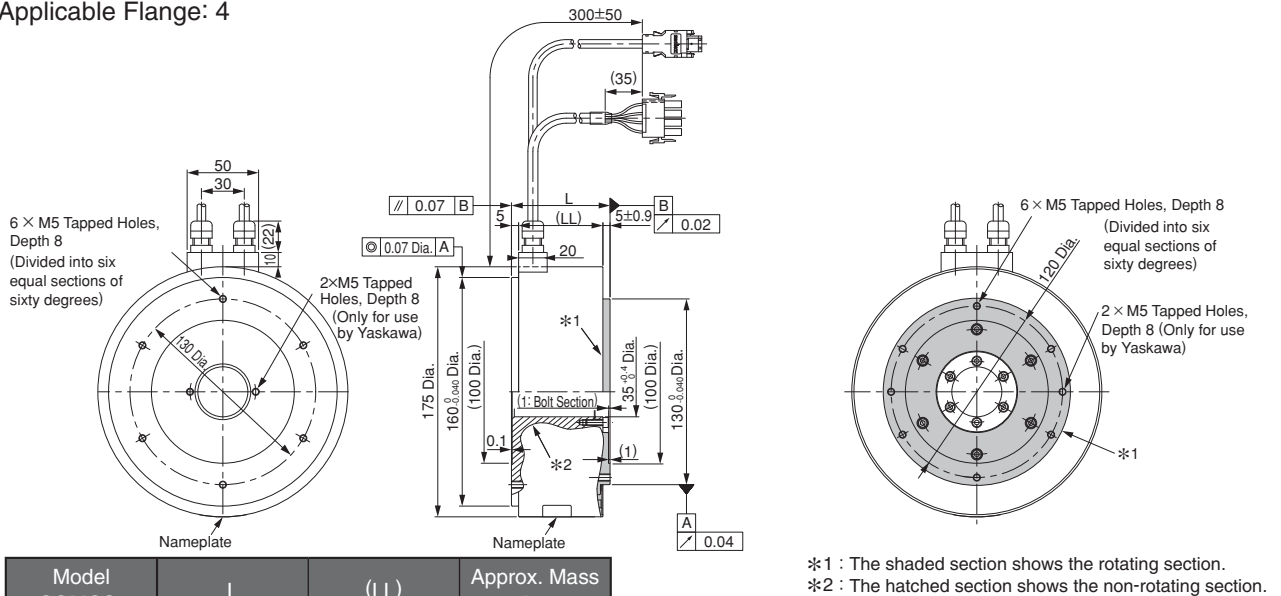

Model SGMCS-	L	(LL)	Approx. Mass kg
04C□C41	69	59	7.2
10C□C41	90	80	10.2
14C□C41	130	120	14.2

● Servomotor Connector (Applicable Flange: 4)

Servomotor-end Connector Specifications

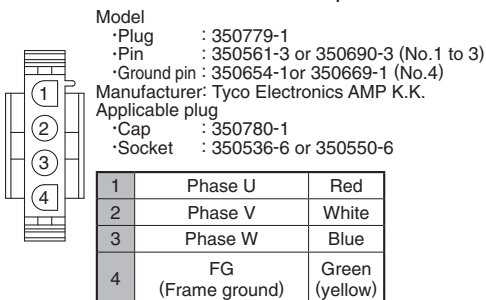

Encoder-end Connector Specifications

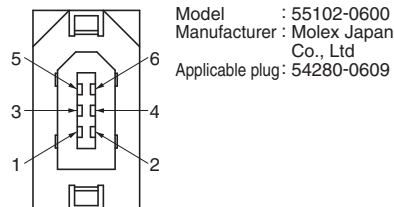

Pin No.	Signal	Color
1	PG5V	Red
2	PG0V	Black
3	-	-
4	-	-
5	PS	Light blue
6	/PS	Light blue/white
Connector Case	FG (Frame ground)	Shield

External Dimensions Units: mm

(3) Rated Torque 8.0 to 25.0 N·m (Outer Diameter 230 mm, Inner Diameter 60 mm)

• Applicable Flange: 1

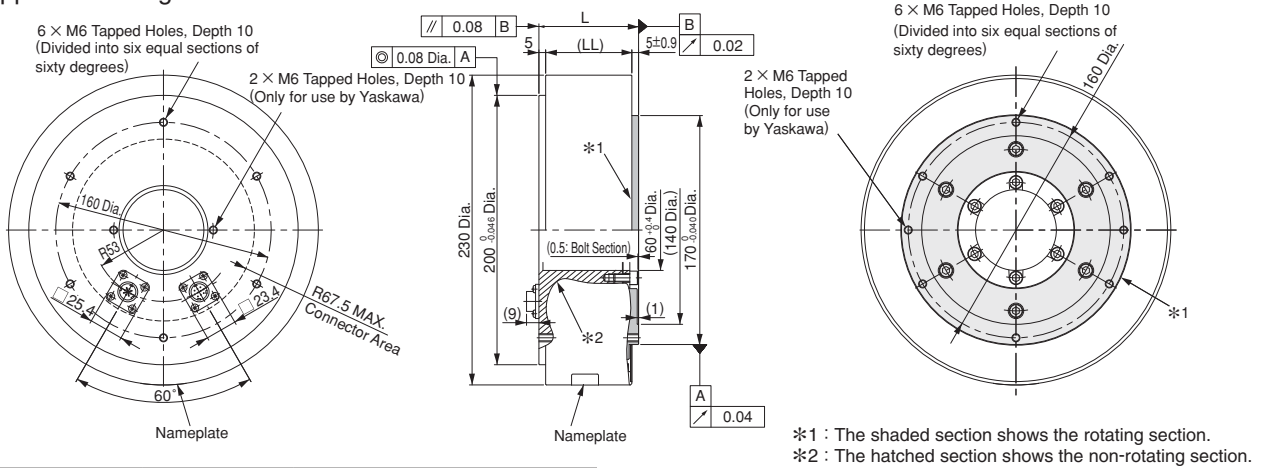

Model SGMCS-	L	(LL)	Approx. Mass kg
08D□C11	74	64	14.0
17D□C11	110	100	22.0
25D□C11	160	150	29.7

• Applicable Flange: 4

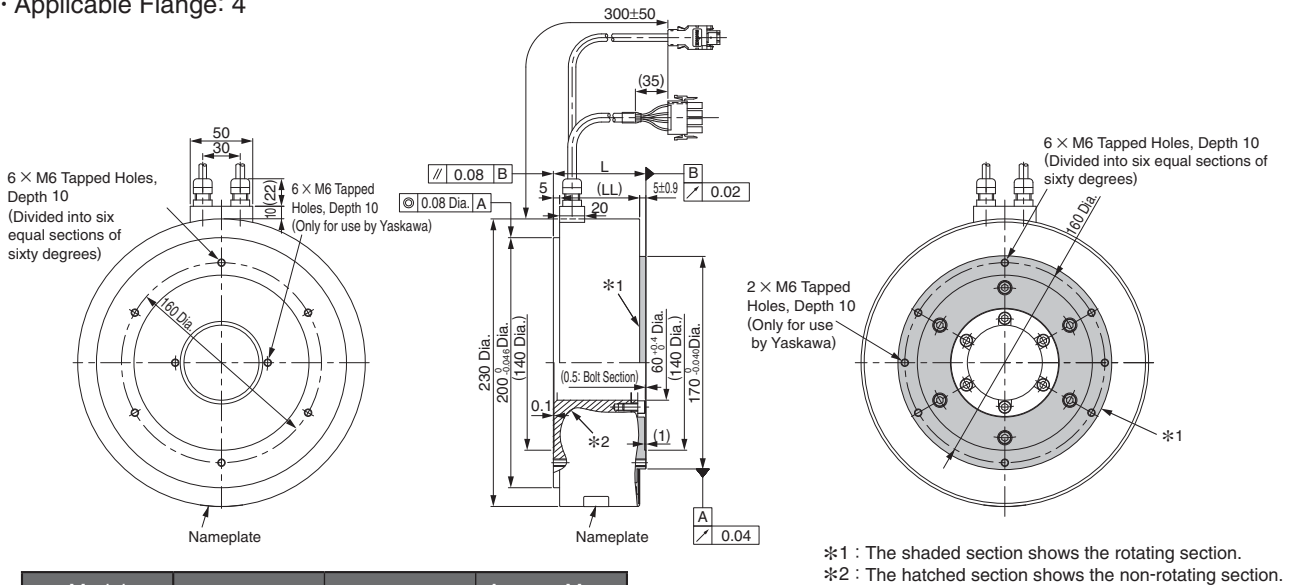

Model SGMCS-	L	(LL)	Approx. Mass kg
08D□C41	74	64	14.0
17D□C41	110	100	22.0
25D□C41	160	150	29.7

External Dimensions Units: mm

(4) Rated Torque 16.0 to 35.0 N·m (Outer Diameter 290 mm, Inner Diameter 75 mm)

• Applicable Flange: 1

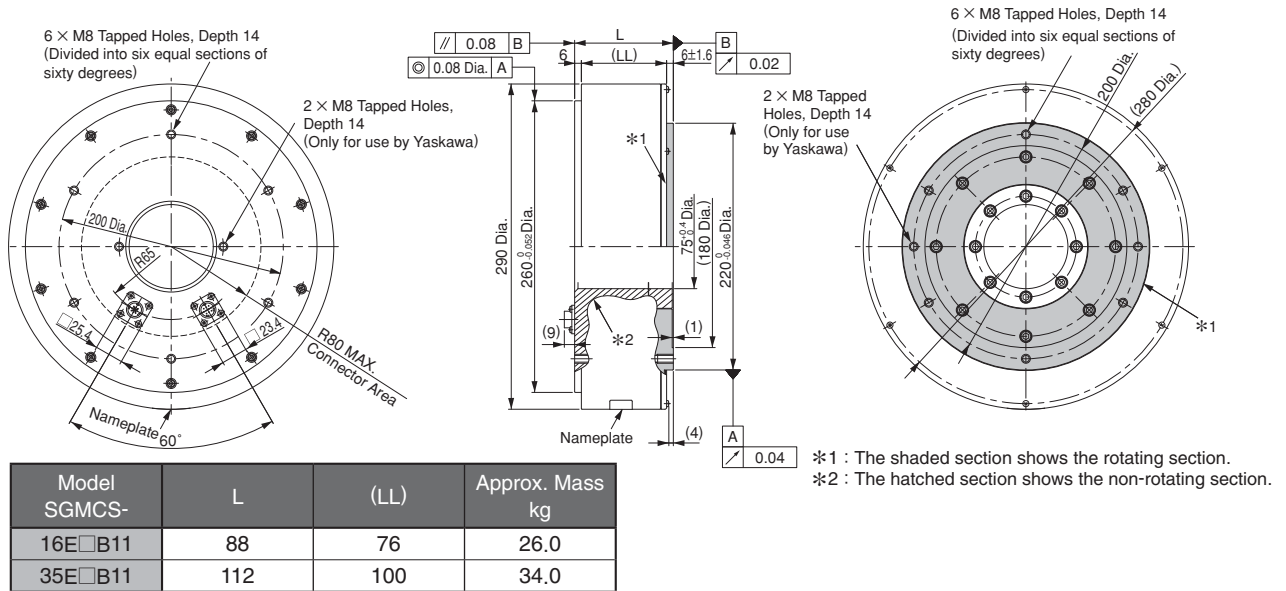

• Applicable Flange: 4

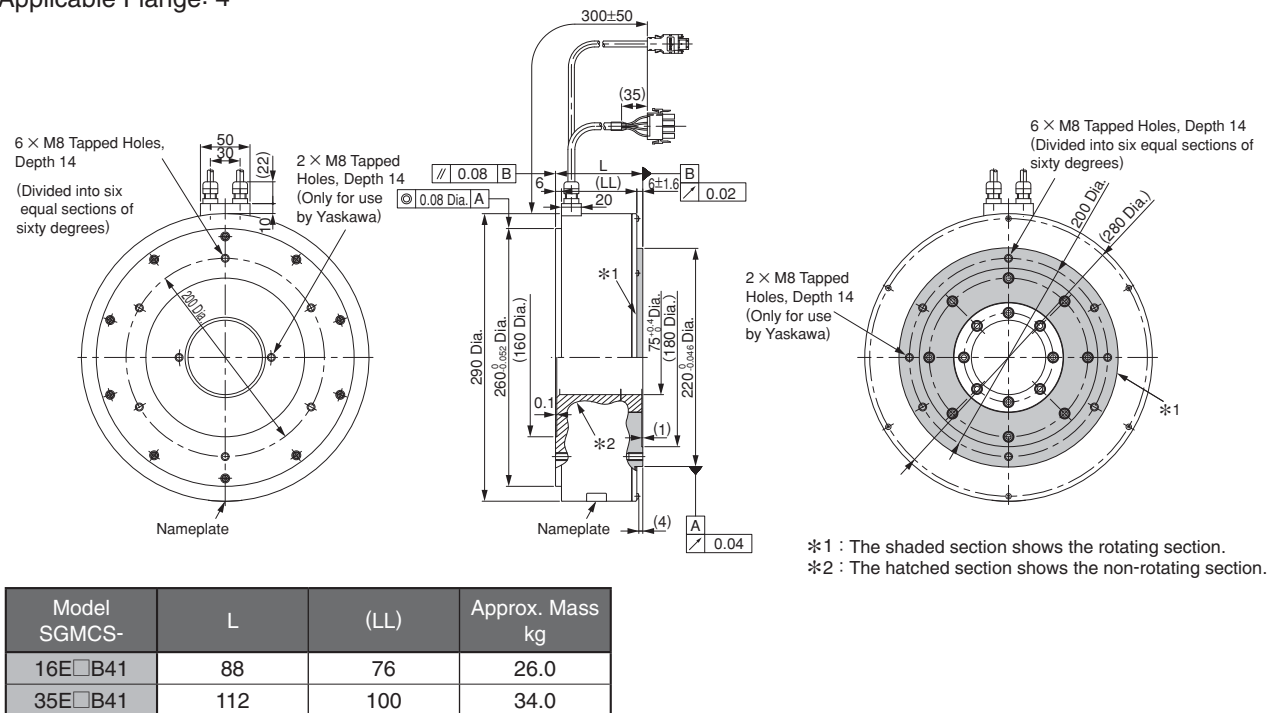

External Dimensions Units: mm

● Medium-capacity Series

(1) Rated Torque 45 to 110 N·m (Outer Diameter 280 mm, Inner Diameter 75 mm)

• Applicable Flange: 2

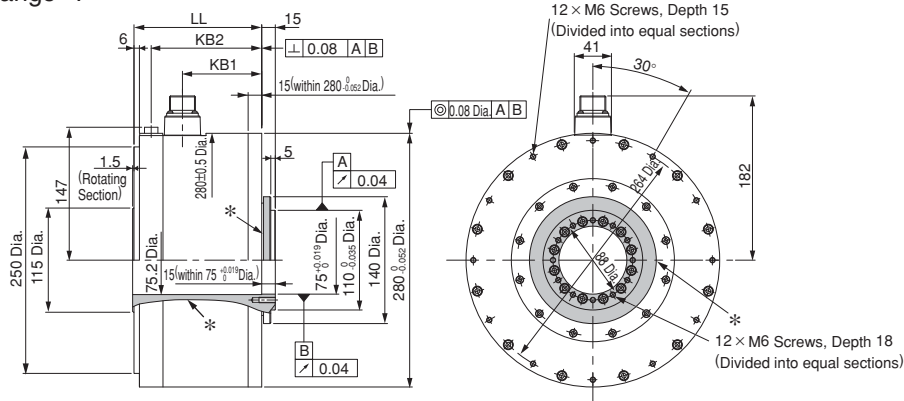

*: The shaded section shows the rotating section.

Model SGMCS-	LL	KB1	KB2	Approx. Mass kg
45M□A11	141	87.5	122	38
80M□A11	191	137.5	172	45
1AM□A11	241	187.5	222	51

• Applicable Flange: 3

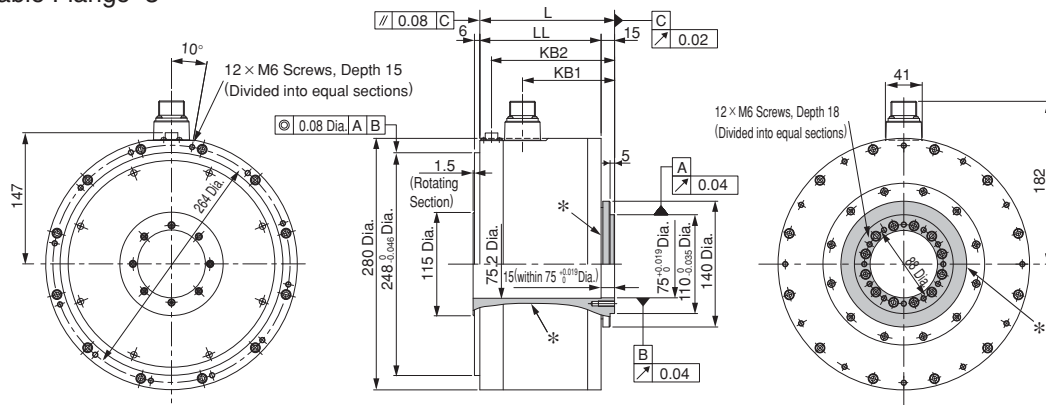

*: The shaded section shows the rotating section.

Model SGMCS-	L	LL	KB1	KB2	Approx. Mass kg
45M□A31	150	135	102.5	137	38
80M□A31	200	185	152.5	187	45
1AM□A31	250	235	202.5	237	51

● Servomotor Connector for Medium-capacity Series Servomotors (Applicable Flange: 1, 3)

Servomotor-end Connector Specifications
(Same for All Medium-capacity Models)

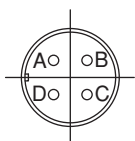

Model : CE05-2A18-10PD
 Manufacturer : DDK Ltd.
 Applicable plug and cable clamp
 Plug : CE05-6A18-10SD-B-BSS
 Cable clamp : CE3057-10A-□(D265)

A	Phase U
B	Phase V
C	Phase W
D	FG (Frame ground)

Encoder-end Connector Specifications
(Same for All Medium-capacity Models)

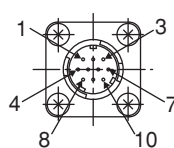

Model : JN1AS10ML1
 Manufacturer : Japan Aviation
 Electronics Industry, Ltd.
 Applicable plug : JN1DS10SL1

1	PS	6	-
2	/PS	7	FG (Frame ground)
3	-	8	-
4	PG5V	9	PG0V
5	-	10	-

External Dimensions Units: mm

(2) Rated Torque 80 to 200 N·m (Outer Diameter 360 mm, Inner Diameter 118 mm)

• Applicable Flange: 1

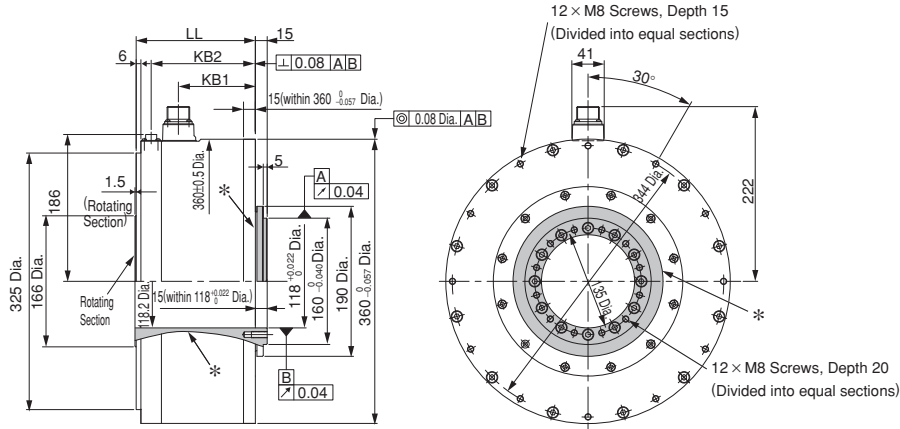

*: The shaded section shows the rotating section.

Model SGMCS-	LL	KB1	KB2	Approx. Mass kg
80N□A11	151	98	132	50
1EN□A11	201	148	182	68
2ZN□A11	251	198	232	86

• Applicable Flange: 3

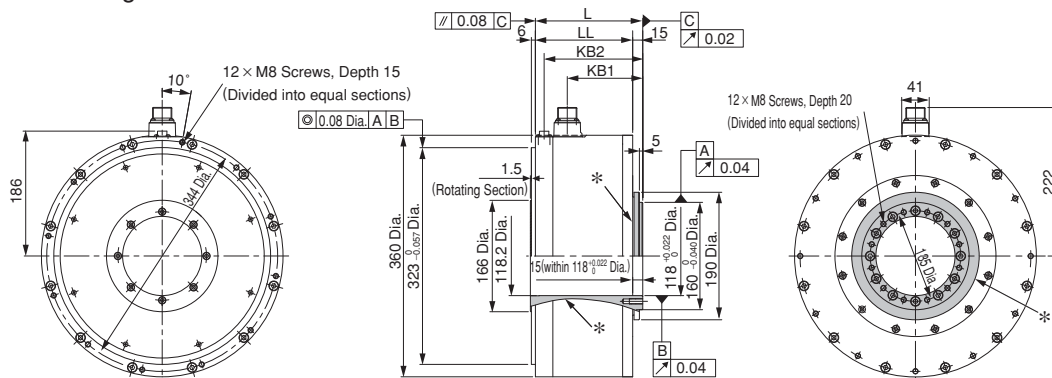

*: The shaded section shows the rotating section.

Model SGMCS-	L	LL	KB1	KB2	Approx. Mass kg
80N□A31	160	145	113	147	50
1EN□A31	210	195	163	197	68
2ZN□A31	260	245	213	247	86

Selecting Cables

●Cables Connections

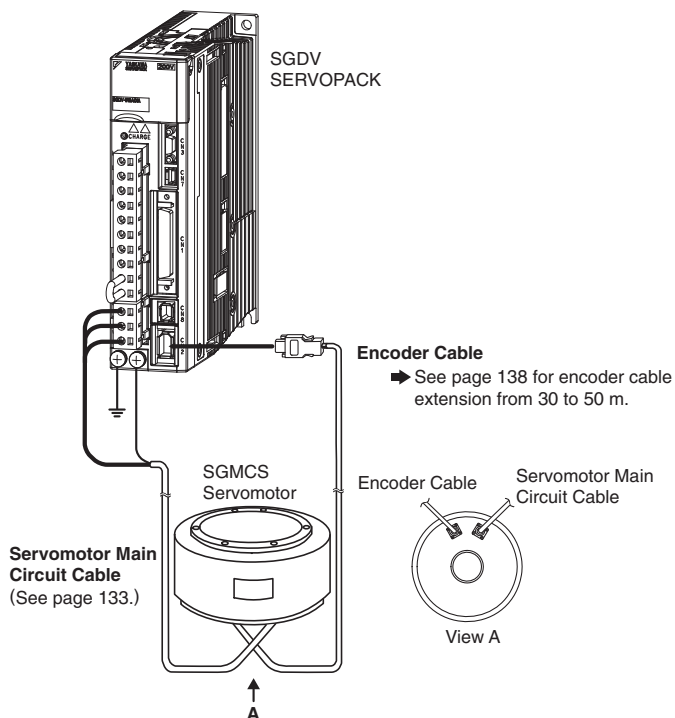

●Servomotor Main Circuit Cables

Name	Length (L)	Order No.		Specifications	Details	
		Standard Type	Flexible Type*1			
Small-capacity Series	Cable with Loose Wire at SERVOPACK End	3 m	JZSP-CMM60-03-E	JZSP-CSM60-03-E	Applicable Flange*2 : 1 SERVOPACK End 50 mm Encoder (Servomotor) End M4 Crimped Terminals	(1)
		5 m	JZSP-CMM60-05-E	JZSP-CSM60-05-E		
		10 m	JZSP-CMM60-10-E	JZSP-CSM60-10-E		
		15 m	JZSP-CMM60-15-E	JZSP-CSM60-15-E		
		20 m	JZSP-CMM60-20-E	JZSP-CSM60-20-E		
	Servomotor-end Connector	3 m	JZSP-CMM00-03-E	JZSP-CMM01-03-E	Applicable Flange*2 : 4 SERVOPACK End 8.5±0.5 (Exposed core wire) 50 Encoder (Servomotor) End Sheath to Bind Core Wires Heat-shrinkable Tube M4 Crimped Terminals Cable: UL2517 (AWG20×4C) Cap : 350780-1(4-pole) Socket: 350536-6(Chained)	(1)
		5 m	JZSP-CMM00-05-E	JZSP-CMM01-05-E		
		10 m	JZSP-CMM00-10-E	JZSP-CMM01-10-E		
		15 m	JZSP-CMM00-15-E	JZSP-CMM01-15-E		
		20 m	JZSP-CMM00-20-E	JZSP-CMM01-20-E		
Cables	JN1DS04FK1		Applicable Flange*2 : 1 Soldered		(2)	
	JZSP-CMM9-3-E		Applicable Flange*2 : 4 Crimping Type (A crimp tool is required.)		(3)	
	5 m	JZSP-CSM90-05-E	JZSP-CSM80-05-E		(4)	
	10 m	JZSP-CSM90-10-E	JZSP-CSM80-10-E			
	15 m	JZSP-CSM90-15-E	JZSP-CSM80-15-E			
20 m	JZSP-CSM90-20-E	JZSP-CSM80-20-E				
50 m	JZSP-CSM90-50-E	JZSP-CSM80-50-E				
Medium-capacity Series: Cables		Contact your Yaskawa representative for cables with connectors and cables and connectors.			(5)	

*1: Use flexible cables for movable sections such as robot arms.
 *2: For applicable flanges, see model designations on page 121.
 Note: SGMCS servomotors with holding brakes are not available.

Selecting Cables

(1) Small-capacity Series: Wiring Specifications for Cables

· Applicable Flange: 1

SERVOPACK End		Servomotor End	
Wire Color	Signal	Signal	Pin No.
Red	Phase U	Phase U	1
White	Phase V	Phase V	2
Blue	Phase W	Phase W	3
Green/(yellow)	FG	FG	4

· Applicable Flange: 4

SERVOPACK End		Servomotor End	
Wire Color	Signal	Signal	Pin No.
Red	Phase U	Phase U	1
White	Phase V	Phase V	2
Blue	Phase W	Phase W	3
Green/(yellow)	FG	FG	4

(2) Small-capacity Series: Servomotor-end Connector Specifications

Items	Specifications
Manufacturer	Japan Aviation Electronics Industry, Ltd.
Order No.	JN1DS04FK1 (Soldered)
Outer Diameter of Applicable Cable	5.7 dia. to 7.3 dia. mm
External Dimensions mm	

(3) Small-capacity Series: Servomotor-end Connector Kit Specifications

Items	Specifications	
Manufacturer	Tyco Electronics AMP K.K.	
Order No.	JZSP-CMM9-3-E	
Cap	350780-1	
Socket	350550-6	
Applicable Wire Size	AWG20 to 14	
Crimp Tool	Hand tool	90296-2
	Applicator	687763-2
External Dimensions mm		

(4) Small-capacity Series: Cable Specifications

Items	Standard Type	Flexible Type
Order No.*	JZSP-CSM90-□□-E (50 m max.)	JZSP-CSM80-□□-E (50 m max.)
Specifications	UL2517 (Rating temperature: 105°C) AWG20 × 6C For power line: AWG20 (0.52 mm ²) Outer diameter of insulating sheath: 1.53 dia. mm For holding brake line: AWG20 (0.52 mm ²) Outer diameter of insulating sheath: 1.53 dia. mm	UL2517 (Rating temperature: 105°C) AWG22 × 6C For power line: AWG22 (0.33 mm ²) Outer diameter of insulating sheath: 1.37 dia. mm For holding brake line: AWG22 (0.33 mm ²) Outer diameter of insulating sheath: 1.37 dia. mm
Finished Dimensions	7 ± 0.3 mm	
Internal Configuration and Lead Color		
Yaskawa Standard Specifications (Standard Length)	Cable length : 5 m, 10 m, 15 m, 20 m, 50 m	

*: Specify the cable length □□ of order no.
Example: JZSP-CSM90-15-E (15 m)

Selecting Cables

(5) Medium-capacity Series (SGMCS-□□M and N): Connector Specifications

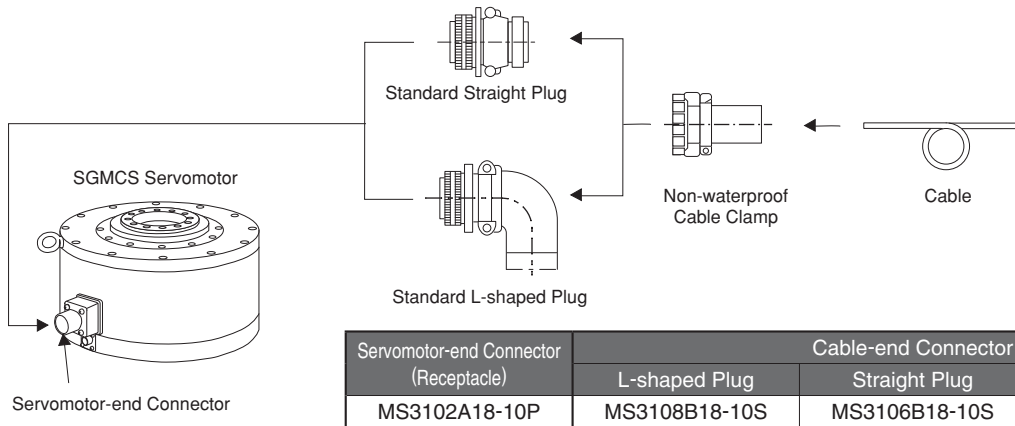

• Dimensional Drawings: MS3108B L-shaped Plug Shell

Units: mm

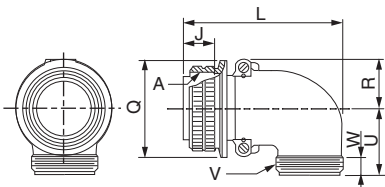

Model No.	Shell Size	Joint Screw A	Length of Joint Portion J ±0.12	Overall Length L Max.	Outer Diameter of Joint Nut Q ⁺⁰ / _{-0.38}	R ±0.5	U ±0.5	Cable Clamp Set Screw V	Effective Screw Length W Min.
MS 3108B	18	1 1/8-18UNEF	18.26	68.27	34.13	20.5	30.2	1-20UNEF	9.53

• Dimensional Drawings: MS3106B Straight Plug Shell

Units: mm

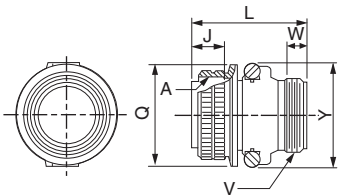

Model No.	Shell Size	Joint Screw A	Length of Joint Portion J ±0.12	Overall Length L Max.	Outer Diameter of Joint Nut Q ⁺⁰ / _{-0.38}	Cable Clamp Set Screw V	Effective Screw Length W Min.	Maximum Width Y Max.
MS 3106B	18	1 1/8-18UNEF	18.26	52.37	34.13	1-20UNEF	9.53	42

• Dimensional Drawings: MS3057-10A Cable Clamp with Rubber Bushing

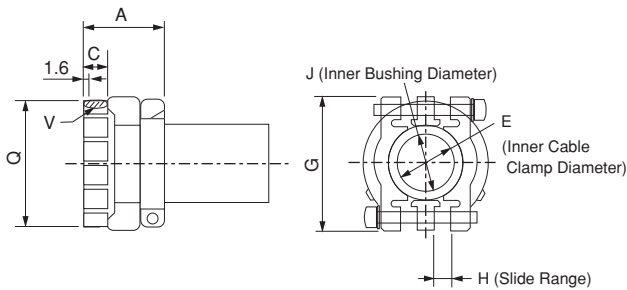



Units: mm

Model No.	Applicable Connector Shell Size	Overall Length A ±0.7	Effective Screw Length C	E	G ±0.7	H	J	Set Screw V	Outer Diameter Q ±0.7	Attached Bushing
MS3057-10A	18	23.8	10.3	15.9	31.7	3.2	14.3	1-20UNEF	30.1	AN3420-10

Selecting Cables

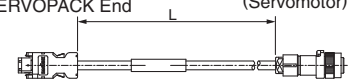
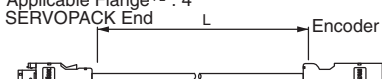
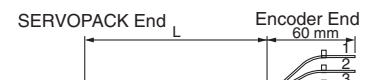
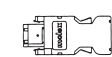
● Encoder Cables and Connectors (Max. length: 20 m)

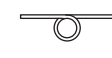
Name	Length (L)	Order No.		Specifications	Details	
		Standard Type	Flexible Type*1			
Cable with Connectors (For Incremental and Absolute Encoder)	3 m	JZSP-CMP60-03-E	JZSP-CSP60-03-E	Applicable Flange*2: 1, 3 SERVOPACK End  Encoder (Servomotor) End Connector (Crimped) (Molex Japan Co., Ltd.) Straight Plug (Crimped) (Japan Aviation Electronics Industry, Ltd.)	(1)	
	5 m	JZSP-CMP60-05-E	JZSP-CSP60-05-E			
	10 m	JZSP-CMP60-10-E	JZSP-CSP60-10-E			
	15 m	JZSP-CMP60-15-E	JZSP-CSP60-15-E			
	20 m	JZSP-CMP60-20-E	JZSP-CSP60-20-E			
	Cable with Loose Wire at Encoder End (For Incremental and Absolute Encoder)	3 m	JZSP-CMP00-03-E	JZSP-CMP10-03-E	Applicable Flange*2 : 4 SERVOPACK End  Encoder End Connector (Crimped) (Molex Japan Co., Ltd.) Socket Connector (Molex Japan Co., Ltd.)	(2)
		5 m	JZSP-CMP00-05-E	JZSP-CMP10-05-E		
		10 m	JZSP-CMP00-10-E	JZSP-CMP10-10-E		
		15 m	JZSP-CMP00-15-E	JZSP-CMP10-15-E		
		20 m	JZSP-CMP00-20-E	JZSP-CMP10-20-E		
Cable with Loose Wire at Encoder End (For Incremental and Absolute Encoder)	3 m	JZSP-CMP03-03-E	JZSP-CMP13-03-E	SERVOPACK End  Encoder End 60 mm Connector (Crimped) (Molex Japan Co., Ltd.) Wire Markers	(3)	
	5 m	JZSP-CMP03-05-E	JZSP-CMP13-05-E			
	10 m	JZSP-CMP03-10-E	JZSP-CMP13-10-E			
	15 m	JZSP-CMP03-15-E	JZSP-CMP13-15-E			
	20 m	JZSP-CMP03-20-E	JZSP-CMP13-20-E			
SERVOPACK-end Connector Kit		JZSP-CMP9-1-E		Soldered  (Molex Japan Co., Ltd.)	(4)	
Encoder-end Connector (Straight Plug)		JN1DS10SL1		Crimping Type (A crimp tool is required.) 		
Encoder-end Connector (Socket Contact)		JN1-22-22S-PKG100		(Japan Aviation Electronics Industry, Ltd.)		
Cables	5 m	JZSP-CMP09-05-E	JZSP-CSP39-05-E		(5)	
	10 m	JZSP-CMP09-10-E	JZSP-CSP39-10-E			
	15 m	JZSP-CMP09-15-E	JZSP-CSP39-15-E			
	20 m	JZSP-CMP09-20-E	JZSP-CSP39-20-E			

*1: Use flexible cables for movable sections such as robot arms.
*2: For applicable flanges, see model designations on page 121.

(1) Wiring Specifications for Cable with Connectors

- Applicable Flange: 1, 3
(Standard type)

SERVOPACK End		Encoder (Servomotor) End	
Pin No.	Signal	Pin No.	Wire Color
1	PG5V	4	Red
2	PG0V	9	Black
5	PS	1	Light blue
6	/PS	2	Light blue/white
Shell	FG	7	FG Shield wire

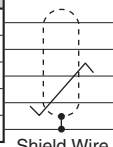

- (Flexible type)

SERVOPACK End		Encoder End	
Pin No.	Signal	Pin No.	Wire Color
1	PG5V	4	Orange
2	PG0V	9	Green
5	PS	1	Black/light blue
6	/PS	2	Red/light blue
Shell	FG	7	FG Shield wire

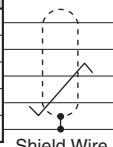

Note: Be sure to connect the shield wire of encoder cable to the connector case (shell).

(2) Wiring Specifications for Cable with Connectors

- Applicable Flange: 4
(Standard type)

SERVOPACK End		Encoder (Servomotor) End	
Pin No.	Signal	Pin No.	Wire Color
1	PG5V	1	Red
2	PG0V	2	Black
5	PS	5	Light blue
6	/PS	6	Light blue/white
Shell	FG	7	FG Shield wire

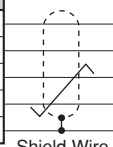

- (Flexible type)

SERVOPACK End		Encoder End	
Pin No.	Signal	Pin No.	Wire Color
1	PG5V	1	Orange
2	PG0V	2	Green
5	PS	5	Red/light blue
6	/PS	6	Black/light blue
Shell	FG	7	FG Shield wire

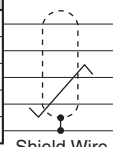

Note: Be sure to connect the shield wire of encoder cable to the connector case (shell).

Selecting Cables

(3) Wiring Specifications for Cable with Loose Wire at Encoder End

(Standard type)

SERVOPACK End		Encoder (Servomotor) End	
Pin No.	Signal	Wire Color	Marker
6	/PS	Light blue/white	6
5	PS	Light blue	5
4	BAT(-)	Orange/white	4
3	BAT(+)	Orange	3
2	PG0V	Black	2
1	PG5V	Red	1
Shell	FG		



(Flexible type)

SERVOPACK End		Encoder (Servomotor) End	
Pin No.	Signal	Wire Color	Marker
1	PG5V	Orange	1
2	PG0V	Green	2
3	BAT(+)	Red/pink	3
4	BAT(-)	Black/pink	4
5	PS	Red/light blue	5
6	/PS	Black/light blue	6
Shell	FG		

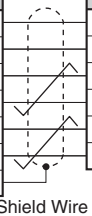

- Notes: 1 The signals BAT(+) and BAT(-) are not needed when using SGMCS servomotors.
 2 Be sure to connect the shield wire of encoder cable to the connector case (shell).

(4) SERVOPACK-end Connector Specifications

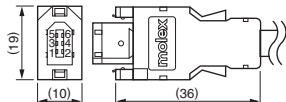
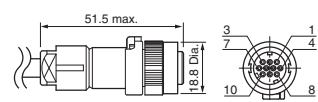
Items	SERVOPACK End	Encoder End
Order No.	JZSP-CMP9-1-E	Tools are not included.
Manufacturer	Molex Japan Co., Ltd.	Japan Aviation Electronics Industry, Ltd.
Connector	55100-0670 (soldered) Note: 55100-0670 (soldered) when using a connector kit	Straight plug: JN1DS10SL1 (crimped) Socket contact type: JN1-22-22S-PKG100 Outer diameter of applicable cable : 5.7 dia. to 7.3 dia. mm Applicable wire size: AWG21 to 25 Outer diameter of insulating sheath: 0.8 dia. to 1.5 dia. mm Crimp tool (hand tool) model: CT150-2-JN
External Dimensions (Units: mm)		

(5) Cable Specifications

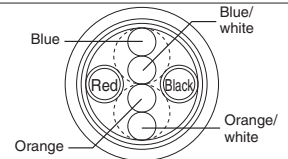
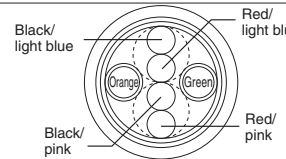
Items	Standard Type	Flexible Type
Order No.*	JZSP-CMP09-□□-E	JZSP-CSP39-□□-E
Cable Length	20 m max.	
Specifications	UL20276 (Rating temperature: 80°C) AWG22×2C+AWG24×2P AWG22 (0.33 mm ²) Outer diameter of insulating sheath: 1.15 dia. mm AWG24 (0.20 mm ²) Outer diameter of insulating sheath: 1.09 dia. mm	UL20276 (Rating temperature: 80°C) AWG22×2C+AWG24×2P AWG22 (0.33 mm ²) Outer diameter of insulating sheath: 1.35 dia. mm AWG24 (0.20 mm ²) Outer diameter of insulating sheath: 1.21 dia. mm
Finished Dimensions	6.5 dia. mm	6.8 dia. mm
Internal Configuration and Lead Colors		
Yaskawa Standard Specifications (Standard Length)	Cable length: 5 m, 10 m, 15 m, 20 m	

- * Specify the cable length in □□ of order no.
 Example: JZSP-CMP09-05-E (5 m)

Selecting Cables

● Relay Encoder Cables (For extending from 30 to 50 m)

Name	Length	Order No. Standard Type	Specifications	Details
Encoder-end Cables (For incremental and absolute encoder)	0.3 m	JZSP-CSP15-E		(1)
Cable with Connectors (For incremental and absolute encoder)	30 m	JZSP-UCMP00-30-E		(2)
	40 m	JZSP-UCMP00-40-E		
	50 m	JZSP-UCMP00-50-E		
Cables	30 m	JZSP-CMP19-30-E		(3)
	40 m	JZSP-CMP19-40-E		
	50 m	JZSP-CMP19-50-E		

(1) Wiring Specifications for Encoder-end Cable

SERVOPACK End		Encoder (Servomotor) End	
Pin No.	Signal	Pin No.	Wire Color
1	PG 5V	4	Red
2	PG 0V	9	Black
5	PS	1	Light blue
6	/PS	2	Light blue/white
Shell	FG	7	FG Shield wire

Note: Be sure to connect the shield wire of encoder cable to the connector case (shell).

(2) Wiring Specifications for Cable with Connectors

SERVOPACK End		Encoder (Servomotor) End	
Pin No.	Signal	Pin No.	Wire Color
6	/PS	6	Light blue/white
5	PS	5	Light blue
4	BAT (-)	4	Orange/white
3	BAT (+)	3	Orange
2	PG 0V	2	Black
1	PG 5V	1	Red
Shell	FG	Shell	FG

(3) Cable Specifications

Items	Standard Type
Order No.*	JZSP-CMP19-□□-E
Cable Length	50 m max.
Specifications	UL20276 (Rating temperature: 80°C) AWG16×2C+AWG26×2P AWG16 (1.31 mm ²) Outer diameter of insulating sheath: 2.0 dia.mm AWG26 (0.13 mm ²) Outer diameter of insulating sheath: 0.91 dia. mm
Finished Dimensions	6.8 dia. mm
Internal Configuration and Lead Colors	
Yaskawa Standard Specifications (Standard Length)	Cable length: 30 m, 40 m, 50 m

* Specify the cable length in □□ of order no.
Example: JZSP-CMP19-30-E (30 m)

Linear Servomotors

SGLGW

(Coreless Type)

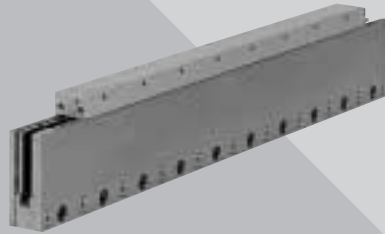

Model Designations

● Moving Coil

SGL G W - 30 A 050 C P □

Linear Σ Series Linear Servomotor

Servomotor Type

Code	Specifications
G	Coreless

W : Moving Coil

Magnet Height

Voltage

A: 200 VAC

Length of Moving Coil

Design Revision Order

A, B, C...

Connector for Main Circuit Cable

Code	Specifications	Applicable Model
Blank	Connector by Tyco Electronics AMP K.K.	All models
D	Connector by Interconnectron GmbH	SGLGW -30A, -40A, -60A

Hall Sensor/Cooling Method

Code	Specifications	Applicable Model
P	With hall sensor	All models
C	Forced cooling	SGLGW-40A, -60A, -90A
H	With hall sensor and forced cooling	-60A, -90A
Blank	Without hall sensor	All models

● Magnetic Way

SGL G M - 30 108 A □

Linear Σ Series Linear Servomotor

Servomotor Type

Code	Specifications
G	Coreless

M: Magnetic Way

Magnet Height

Length of Magnetic Way

Options

Code	Specifications	Applicable Model
Blank	(standard)	All models
-M	High force	SGLGM-40, -60

Design Revision Order

A, B, C*...

*: The coreless linear servomotor has revision CT.
 C = without mounting holes on the bottom
 CT = with mounting holes on the bottom

Features

- Direct-feed mechanism for high-speed and high-precision positioning.
- Lack of magnetic attraction force helps extend the life of linear motion guides and minimizes noise.
- Zero cogging for minimal force ripple.

Application Examples

- Feeders and loaders
- Semiconductor equipment
- LCD manufacturing equipment

● Precautions on Moving Coil with Hall Sensor

When using a moving coil with a hall sensor, the magnetic way must completely cover the bottom of the hall sensor. Refer to the example showing the correct installation.

When determining the length of the moving coil's stroke or the length of the magnetic way, consider the total length of the moving coil and the hall sensor unit. Refer to the following table.

< Correct >

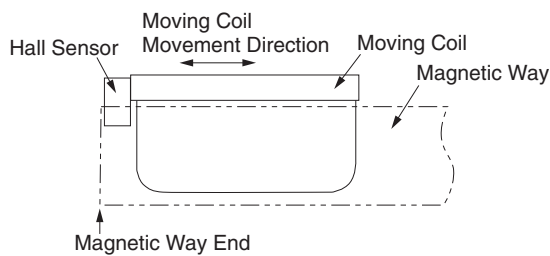

< Incorrect >

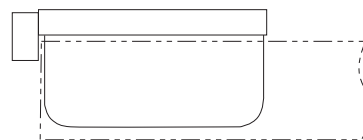

The total length of moving coil with hall sensor

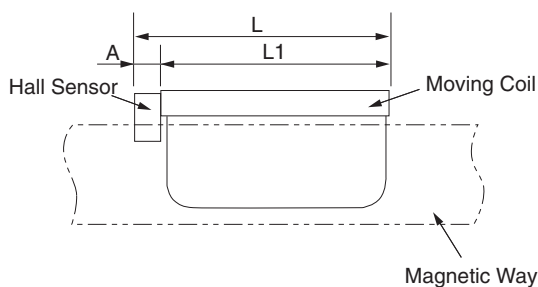

Moving Coil Model SGLGW-	Length of Moving Coil L1 (mm)	Length of Hall Sensor Unit A (mm)	Total Length L (mm)
30A050□P□	50	0 (Included in the length of moving coil)	50
30A080□P□	80		80
40A140□P□	140	16	156
40A253□P□	252.5		268.5
40A365□P□	365		381
60A140□P□	140	16	156
60A253□P□	252.5		268.5
60A365□P□	365		381
90A200□P□	199	0 (Included in the length of moving coil)	199
90A370□P□	367		367
90A535□P□	535		535

Ratings and Specifications

Time Rating: Continuous

Insulation Resistance: 500 VDC, 10 MΩ min.

Ambient Temperature: 0 to 40°C

Excitation: Permanent magnet

Withstand Voltage: 1500 VAC for one minute

Enclosure: Self-cooled, air-cooling (Only self-cooled type available for SGLGW-30A linear servomotor)

Ambient Humidity: 20% to 80% (no condensation)

Allowable Winding Temperature: 130°C (Thermal class B)

● With Standard-force Magnetic Ways

Linear Servomotor Model SGLGW- <input type="text"/>		30A		40A			60A			90A		
		050C	080C	140C	253C	365C	140C	253C	365C	200C	370C	535C
Peak Speed*	m/s	5	5	5	5	5	4.8	4.8	4.8	4	4	4
Rated Force*	N	12.5	25	47	93	140	70	140	210	325	550	750
Rated Current*	Arms	0.51	0.79	0.8	1.6	2.4	1.2	2.2	3.3	4.4	7.5	10.2
Peak Force*	N	40	80	140	280	420	220	440	660	1300	2200	3000
Peak Current*	Arms	1.62	2.53	2.4	4.9	7.3	3.5	7.0	10.5	17.6	30.0	40.8
Moving Coil Mass	kg	0.10	0.15	0.34	0.60	0.87	0.42	0.76	1.10	2.15	3.6	4.9
Force Constant	N/Arms	26.4	33.9	61.5	61.5	61.5	66.6	66.6	66.6	78.0	78.0	78.0
BEMF Constant	V/(m/s)	8.8	11.3	20.5	20.5	20.5	22.2	22.2	22.2	26.0	26.0	26.0
Motor Constant	N/√W	3.7	5.6	7.8	11.0	13.5	11.1	15.7	19.2	26.0	36.8	45.0
Electrical Time Constant	ms	0.2	0.4	0.4	0.4	0.4	0.5	0.5	0.5	1.4	1.4	1.4
Mechanical Time Constant	ms	7.30	4.78	5.59	4.96	4.77	3.41	3.08	2.98	3.18	2.66	2.42
Thermal Resistance (With heat sink)	K/W	5.19	3.11	1.67	0.87	0.58	1.56	0.77	0.51	0.39	0.26	0.22
Thermal Resistance (Without heat sink)	K/W	8.13	6.32	3.02	1.80	1.23	2.59	1.48	1.15	1.09	0.63	0.47
Magnetic Attraction	N	0	0	0	0	0	0	0	0	0	0	0
Applicable SERVOPACK	SGDV-	R70A	R90A	R90A	1R6A	2R8A	1R6A	2R8A	5R5A	120A	180A	200A

Notes: 1 The items marked with an * and *Force and Speed Characteristics* (the table on the next page) are the values at a motor winding temperature of 100°C during operation in combination with a SERVOPACK. The others are at 20°C.

2 The above specifications show the values under the cooling condition when a heat sink (aluminum board) listed in the following table is mounted on the moving coil.

Heat Sink Size	200 mm × 300 mm × 12 mm : SGLGW-30A050C, -30A080C, -40A140C, -60A140C
	300 mm × 400 mm × 12 mm : SGLGW-40A253C, -60A253C
	400 mm × 500 mm × 12 mm : SGLGW-40A365C, -60A365C
	800 mm × 900 mm × 12 mm : SGLGW-90A200C, -90A370C, -90A535C

Ratings and Specifications

● Force and Speed Characteristics [A] : Continuous Duty Zone [B] : Intermittent Duty Zone

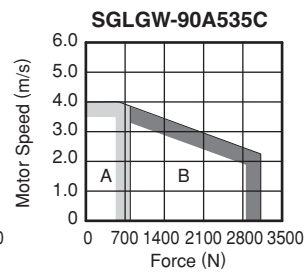
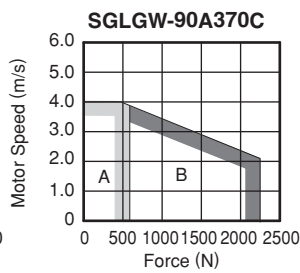
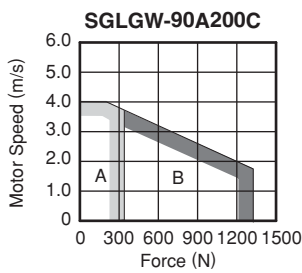
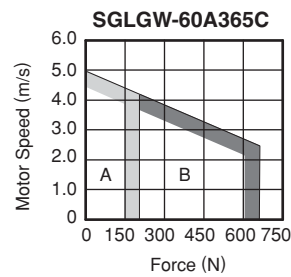
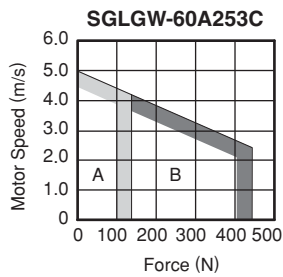
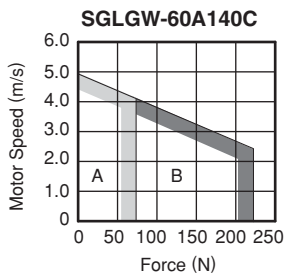
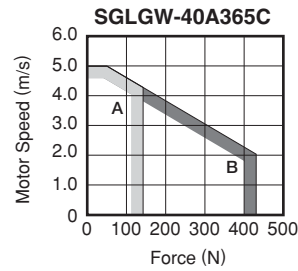
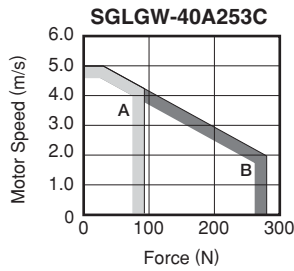
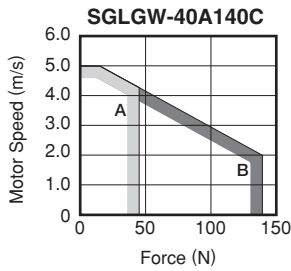
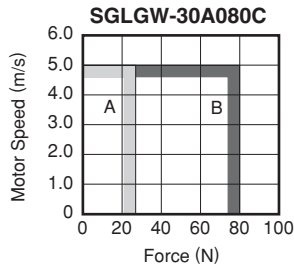
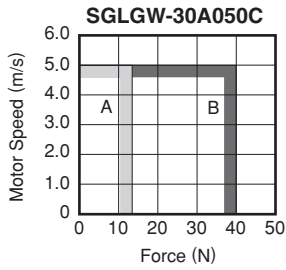

Note: When the effective force during intermittent duty is within the rated force, the servomotor can be used within the intermittent duty zone.

Ratings and Specifications

●With High-force Magnetic Ways

Linear Servomotor Model SGLGW- <input type="text"/>		40A			60A		
		140C	253C	365C	140C	253C	365C
Peak Speed*	m/s	4.2	4.2	4.2	4.2	4.2	4.2
Rated Force*	N	57	114	171	85	170	255
Rated Current*	Arms	0.8	1.6	2.4	1.2	2.2	3.3
Peak Force*	N	230	460	690	360	720	1080
Peak Current*	Arms	3.2	6.5	9.7	5.0	10.0	14.9
Moving Coil Mass	kg	0.34	0.60	0.87	0.42	0.76	1.10
Force Constant	N/Arms	76.0	76.0	76.0	77.4	77.4	77.4
BEMF Constant	V/(m/s)	25.3	25.3	25.3	25.8	25.8	25.8
Motor Constant	N/ \sqrt{W}	9.6	13.6	16.7	12.9	18.2	22.3
Electrical Time Constant	ms	0.4	0.4	0.4	0.5	0.5	0.5
Mechanical Time Constant	ms	3.69	3.24	3.12	2.52	2.29	2.21
Thermal Resistance (With heat sink)	K/W	1.67	0.87	0.58	1.56	0.77	0.51
Thermal Resistance (Without heat sink)	K/W	3.02	1.80	1.23	2.59	1.48	1.15
Magnetic Attraction	N	0	0	0	0	0	0
Applicable SERVOPACK	SGDV-	1R6A	2R8A	3R8A	1R6A	3R8A	7R6A

Notes: 1 The items marked with an * and *Force and Speed Characteristics* (the table on the next page) are the values at a motor winding temperature of 100°C during operation in combination with a SERVOPACK. The others are at 20°C.

2 The above specifications show the values under the cooling condition when a heat sink (aluminum board) listed in the following table is mounted on the moving coil.

[Heat Sink Size] 200 mm × 300 mm × 12 mm : SGLGW-40A140C, -60A140C
 300 mm × 400 mm × 12 mm : SGLGW-40A253C, -60A253C
 400 mm × 500 mm × 12 mm : SGLGW-40A365C, -60A365C

Ratings and Specifications

● **Force and Speed Characteristics** **A** : Continuous Duty Zone **B** : Intermittent Duty Zone

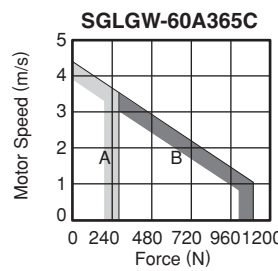
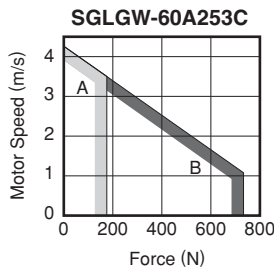
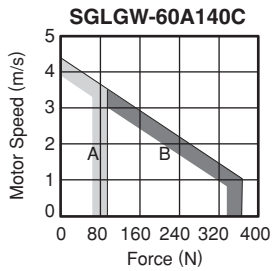
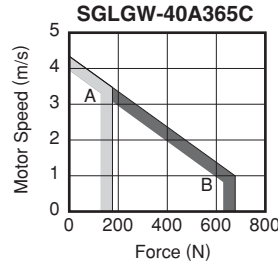
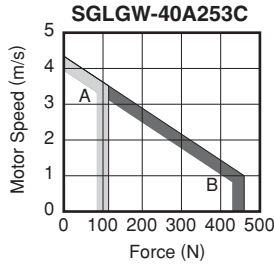
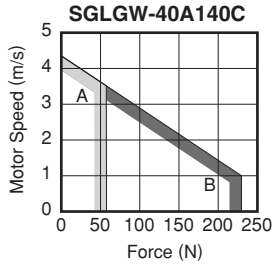

Note: When the effective force during intermittent duty is within the rated force, the servomotor can be used within the intermittent duty zone.

● **Mechanical Specifications**

(1) **Impact Resistance**

- Impact acceleration: 196 m/s²
- Impact occurrences: twice

(2) **Vibration Resistance**

The linear servomotors will withstand the following vibration acceleration in three directions: Vertical, side to side, and front to back.

- Vibration acceleration: 49 m/s²

External Dimensions Units: mm

(1) SGLGW-30

- Moving Coil: SGLGW-30A□□□C□ (With a connector by Tyco Electronics AMP K.K.)

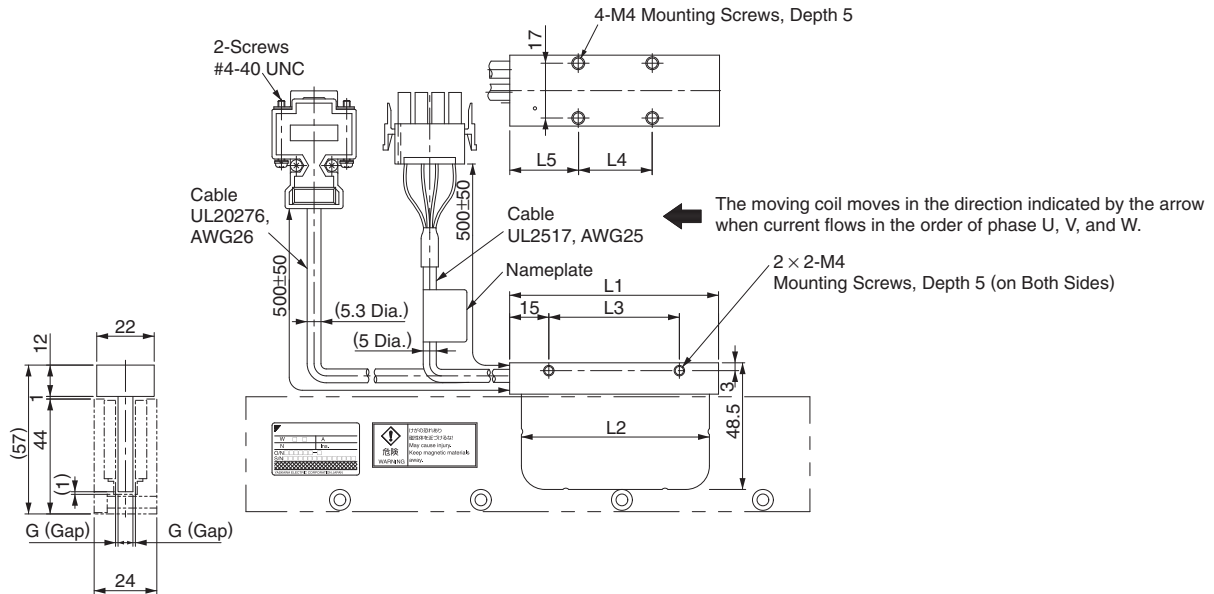

Hall Sensor Connector Specifications

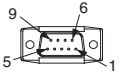

Pin Connector:
17JE-23090-02 (D8C)
by DDK Ltd.

The Mating Connector

Socket Connector
: 17JE-13090-02 (D8C)
Stud : 17L-002C or
17L-002C1

Pin No.	Signal
1	+5V (Power supply)
2	Phase U
3	Phase V
4	Phase W
5	0V (Power supply)
6	Not used
7	Not used
8	Not used
9	Not used

Linear Servomotor Connector Specifications

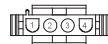

Plug : 350779-1
Pin : 350924-1 or
770672-1
by Tyco Electronics AMP K.K.

The Mating Connector

Cap : 350780-1
Socket : 350925-1 or
770673-1

Pin No.	Signal	Wire Color
1	Phase U	Red
2	Phase V	White
3	Phase W	Blue
4	FG	Green

Hall Sensor Output Signals

When the moving coil moves in the direction indicated by the arrow in the figure, the relationship between the hall sensor output signals S_u , S_v , S_w and the inverse power of each motor phase V_u , V_v , V_w becomes as shown in the figure below.

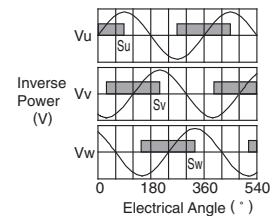

Moving Coil Model SGLGW-	L1	L2	L3	L4	L5	G (Gap)	Approx. Mass* kg
30A050C□	50	48	30	20	20	0.85	0.14
30A080C□	80	72	50	30	25	0.95	0.19

*: The values indicate the mass of moving coil with a hall sensor unit.

External Dimensions Units: mm

- Moving Coil: SGLGW-30A□□□□D (With a connector by Interconnectron GmbH)

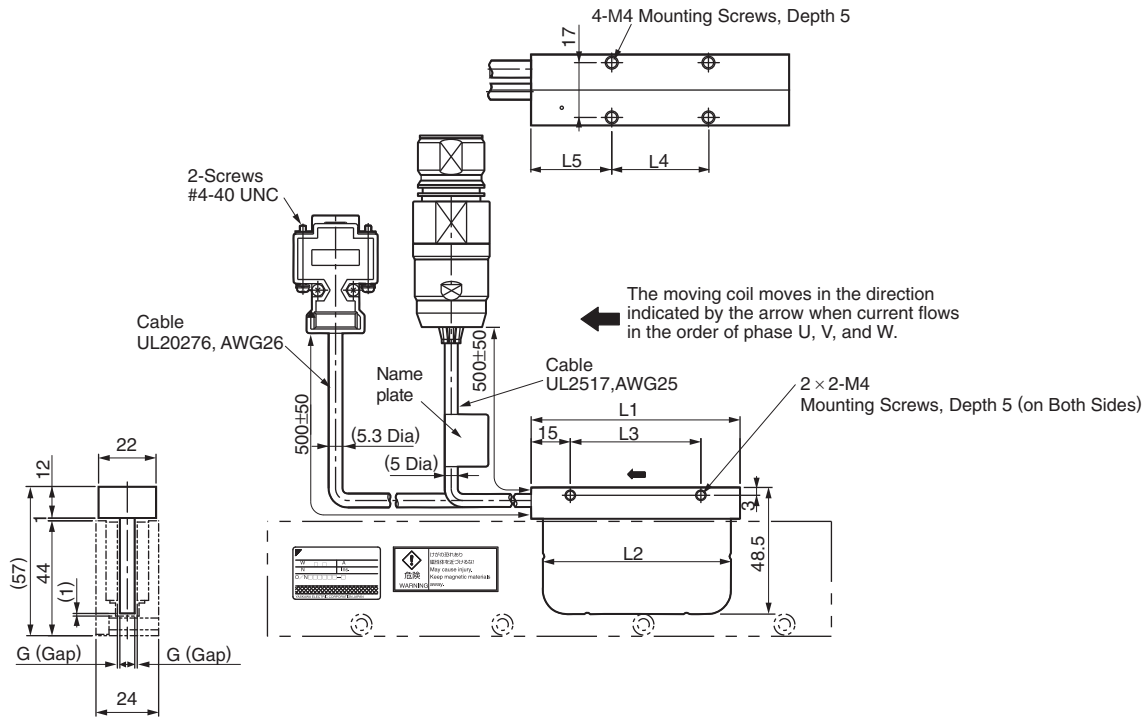

Hall Sensor Connector Specifications



Pin Connector : 17JE-23090-02 (D8C) by DDK Ltd.

The Mating Connector
 Socket Connector : 17JE-13090-02 (D8C)
 Stud : 17L-002C or 17L-002C1

Pin No.	Signal
1	+5V (Power supply)
2	Phase U
3	Phase V
4	Phase W
5	0V (Power supply)
6	Not used
7	Not used
8	Not used
9	Not used

Linear Servomotor Connector Specifications



Extension: SROC06JM5CN169
 Pin : 021.423.1020
 by Interconnectron GmbH

The Mating Connector
 Plug : SPUC06KFSDN236
 Socket: 020.030.1020

Pin No.	Signal	Wire Color
1	Phase U	Red
2	Phase V	White
3	Phase W	Blue
4	Not used	-
5	Not used	-
6	FG	Green

Hall Sensor Output Signals

When the moving coil moves in the direction indicated by the arrow in the figure, the relationship between the hall sensor output signals Su, Sv, Sw and the inverse power of each motor phase Vu, Vv, Vw becomes as shown in the figure below.

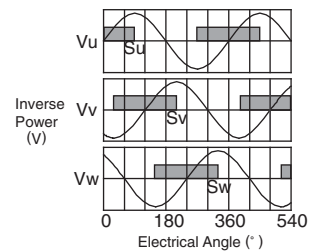

Moving Coil Model SGLGW-	L1	L2	L3	L4	L5	G (Gap)	Approx. Mass* kg
30A050C□D	50	48	30	20	20	0.85	0.14
30A080C□D	80	72	50	30	25	0.95	0.19

*: The values indicate the mass of moving coil with a hall sensor unit.

External Dimensions Units: mm

• Magnetic Way: SGLGM-30□□□A

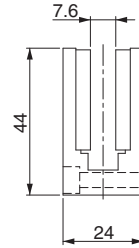
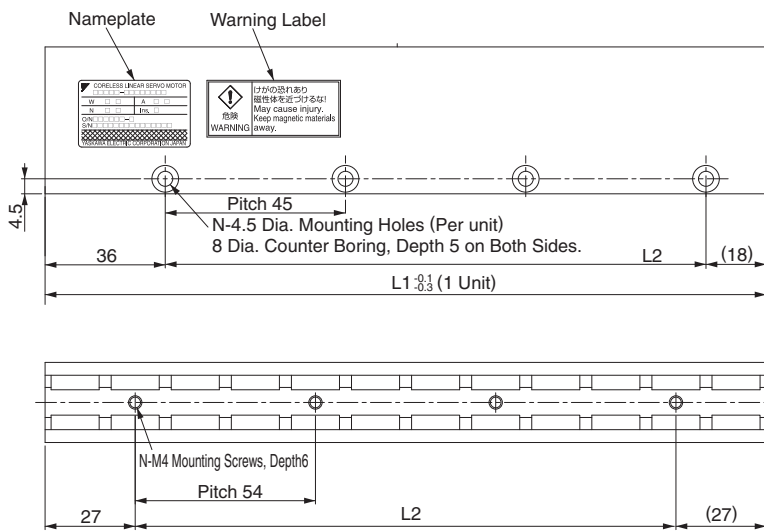

Magnetic Way Model SGLGM-	L1	L2	N	Approx. Mass kg
30108A	108	54	2	0.6
30216A	216	162	4	1.1
30432A	432	378	8	2.3

Note: If you have a pacemaker or any other electronic medical device, do not go near the magnetic way of the linear servomotor.

External Dimensions Units: mm

(2) SGLGW-40

- Moving Coil: SGLGW-40A□□□C□ (With a connector by Tyco Electronics AMP K.K.)

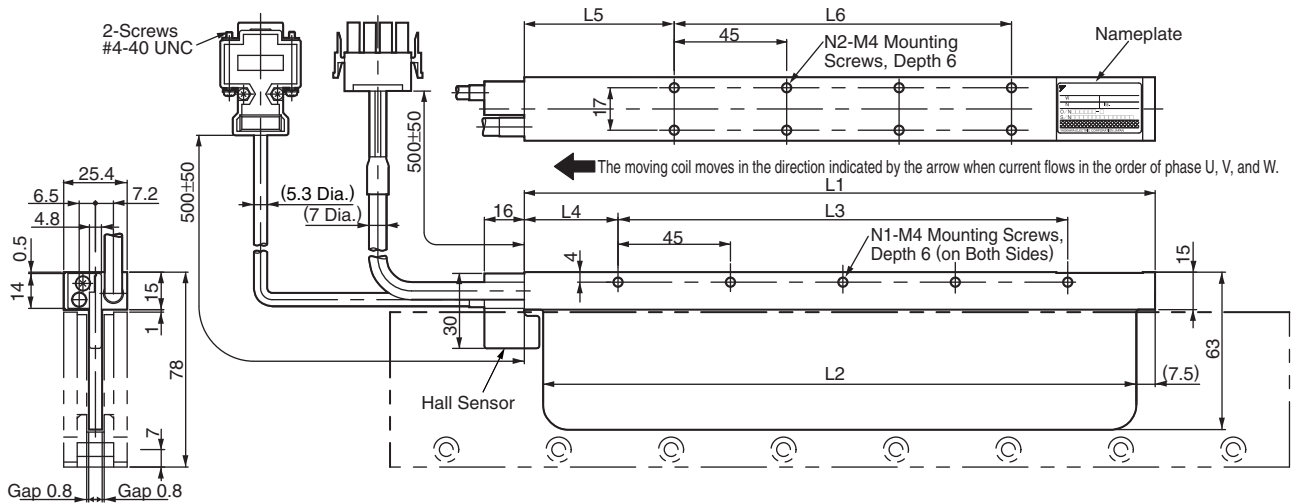

Hall Sensor Connector Specifications

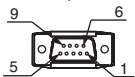

Pin Connector :
 17JE-23090-02 (D8C)
 by DDK Ltd.

The Mating Connector

Socket Connector :
 17JE-13090-02 (D8C)
 Stud : 17L-002C or
 17L-002C1

Pin No.	Signal
1	+5V (Power supply)
2	Phase U
3	Phase V
4	Phase W
5	0V (Power supply)
6	Not used
7	Not used
8	Not used
9	Not used

Linear Servomotor Connector Specifications



Plug : 350779-1
 Pin : 350561-3 or
 350690-3 (No.1 to 3)
 350654-1
 350669-1 (No.4)
 by Tyco Electronics AMP K.K.

The Mating Connector
 Cap : 350780-1
 Socket : 350570-3 or
 350689-3

Pin No.	Signal	Wire Color
1	Phase U	Red
2	Phase V	White
3	Phase W	Blue
4	FG	Green

Hall Sensor Output Signals

When the moving coil moves in the direction indicated by the arrow in the figure, the relationship between the hall sensor output signals Su, Sv, Sw and the inverse power of each motor phase Vu, Vv, Vw becomes as shown in the figure below.

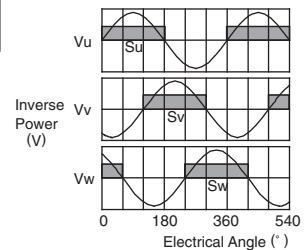

Moving Coil Model SGLGW-	L1	L2	L3	L4	L5	L6	N1	N2	Approx. Mass* kg
40A140C□	140	125	90	30	52.5	45	3	4	0.40
40A253C□	252.5	237.5	180	37.5	60	135	5	8	0.66
40A365C□	365	350	315	30	52.5	270	8	14	0.93

*: The values indicate the mass of moving coil with a hall sensor unit.

External Dimensions Units: mm

- Moving Coil: SGLGW-40A□□□C□D (With a connector by Interconnectron GmbH)

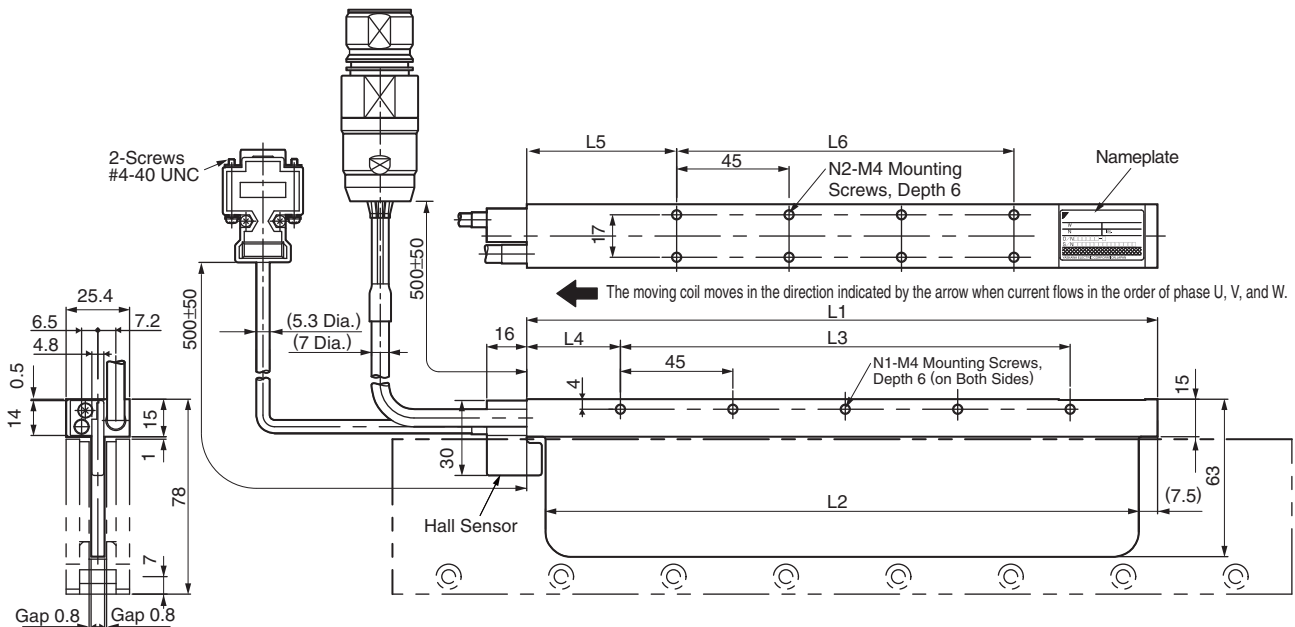

Hall Sensor Connector Specifications

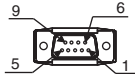

Pin Connector :
17JE-23090-02 (D8C)
by DDK Ltd.

The Mating Connector
Socket Connector :
17JE-13090-02 (D8C)
Stud : 17L-002C or
17L-002C1

Pin No.	Signal
1	+5V (Power supply)
2	Phase U
3	Phase V
4	Phase W
5	0V (Power supply)
6	Not used
7	Not used
8	Not used
9	Not used

Linear Servomotor Connector Specifications



Extension: SROC06JM5CN169
Pin : 021.423.1020
by Interconnectron GmbH

The Mating Connector

Plug : SPUC06KFSDN236
Socket: 020.030.1020

Pin No.	Signal	Wire Color
1	Phase U	Red
2	Phase V	White
3	Phase W	Blue
4	Not used	-
5	Not used	-
6	FG	Green

Hall Sensor Output Signals

When the moving coil moves in the direction indicated by the arrow in the figure, the relationship between the hall sensor output signals S_u , S_v , S_w and the inverse power of each motor phase V_u , V_v , V_w becomes as shown in the figure below.

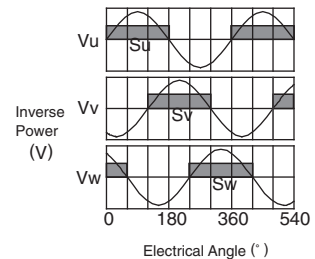

Moving Coil Model SGLGW-	L1	L2	L3	L4	L5	L6	N1	N2	Approx. Mass* kg
40A140C□D	140	125	90	30	52.5	45	3	4	0.40
40A253C□D	252.5	237.5	180	37.5	60	135	5	8	0.66
40A365C□D	365	350	315	30	52.5	270	8	14	0.93

*: The values indicate the mass of moving coil with a hall sensor unit.

External Dimensions Units: mm

- Magnetic Way : SGLGM-40□□□C (Without mounting holes on the bottom)
 SGLGM-40□□□CT (With mounting holes on the bottom)

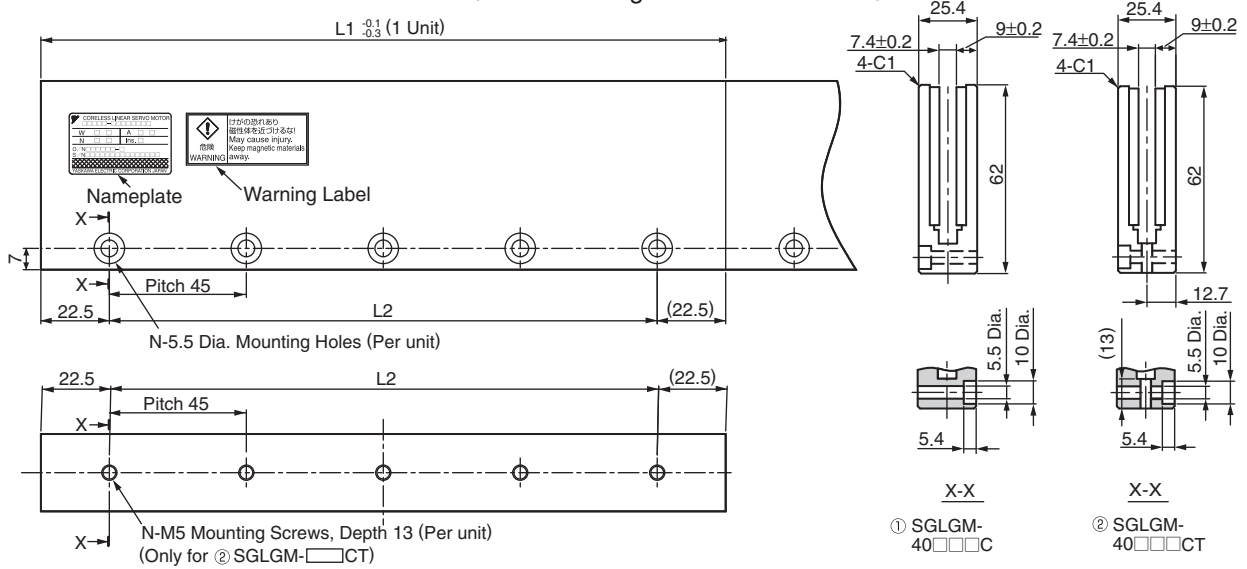

Type	Standard-force Magnetic Way Model SGLGM-	L1	L2	N	Approx. Mass kg
Standard Force	40090C or 40090CT	90	45	2	0.8
	40225C or 40225CT	225	180	5	2.0
	40360C or 40360CT	360	315	8	3.1
	40405C or 40405CT	405	360	9	3.5
	40450C or 40450CT	450	405	10	3.9

Note: If you have a pacemaker or any other electronic medical device, do not go near the magnetic way of the linear servomotor.

- High-force Magnetic Way : SGLGM-40□□□C-M (Without mounting holes on the bottom)
 SGLGM-40□□□CT-M (With mounting holes on the bottom)

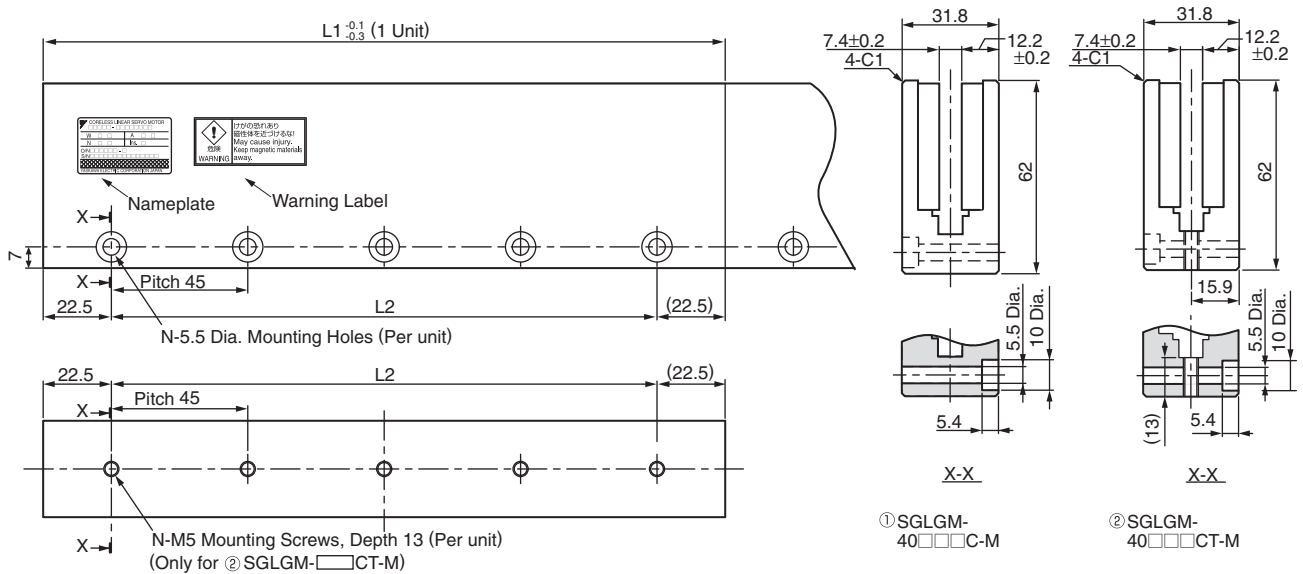

Type	High-force Magnetic Way Model SGLGM-	L1	L2	N	Approx. Mass kg
High Force	40090C-M or 40090CT-M	90	45	2	1.0
	40225C-M or 40225CT-M	225	180	5	2.6
	40360C-M or 40360CT-M	360	315	8	4.1
	40405C-M or 40405CT-M	405	360	9	4.6
	40450C-M or 40450CT-M	450	405	10	5.1

Note: If you have a pacemaker or any other electronic medical device, do not go near the magnetic way of the linear servomotor.

External Dimensions Units: mm

(3) SGLGW-60

- Moving Coil: SGLGW-60A□□□C□ (With a connector by Tyco Electronics AMP K.K.)

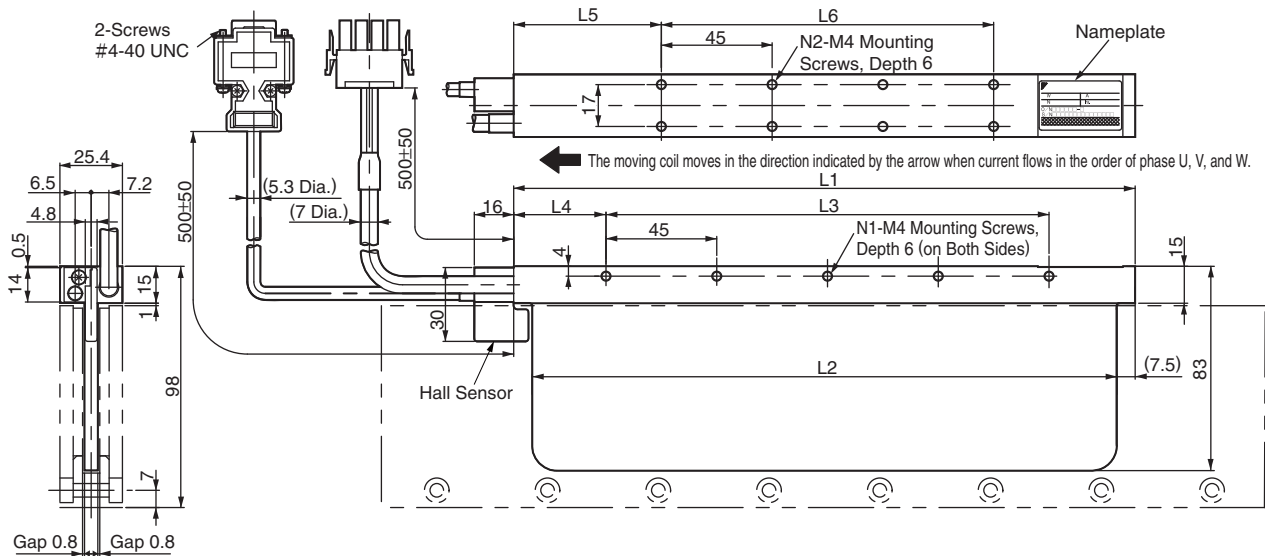

Hall Sensor Connector Specifications

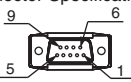

Pin Connector :
17JE-23090-02 (D8C)
by DDK Ltd.

The Mating Connector

Socket Connector :
17JE-13090-02 (D8C)
Stud : 17L-002C or
17L-002C1

Pin No.	Signal
1	+5V (Power supply)
2	Phase U
3	Phase V
4	Phase W
5	0V (Power supply)
6	Not used
7	Not used
8	Not used
9	Not used

Linear Servomotor Connector Specifications

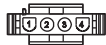

Plug : 350779-1
Pin : 350561-3 or
350690-3 (No.1 to 3)
350654-1
350669-1 (No.4)
by Tyco Electronics AMP K.K.

The Mating Connector

Cap : 350780-1
Socket : 350570-3 or
350689-3

Pin No.	Signal	Wire Color
1	Phase U	Red
2	Phase V	White
3	Phase W	Blue
4	FG	Green

Hall Sensor Output Signals

When the moving coil moves in the direction indicated by the arrow in the figure, the relationship between the hall sensor output signals S_u , S_v , S_w and the inverse power of each motor phase V_u , V_v , V_w becomes as shown in the figure below.

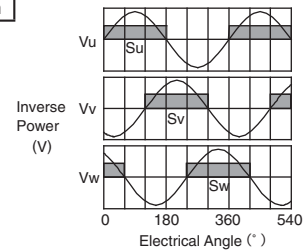

Moving Coil Model SGLGW-	L1	L2	L3	L4	L5	L6	N1	N2	Approx. Mass* kg
60A140C□	140	125	90	30	52.5	45	3	4	0.48
60A253C□	252.5	237.5	180	37.5	60	135	5	8	0.82
60A365C□	365	350	315	30	52.5	270	8	14	1.16

*: The values indicate the mass of moving coil with a hall sensor unit.

External Dimensions Units: mm

- Moving Coil: SGLGW-60A□□□□D (With a connector by Interconnectron GmbH)

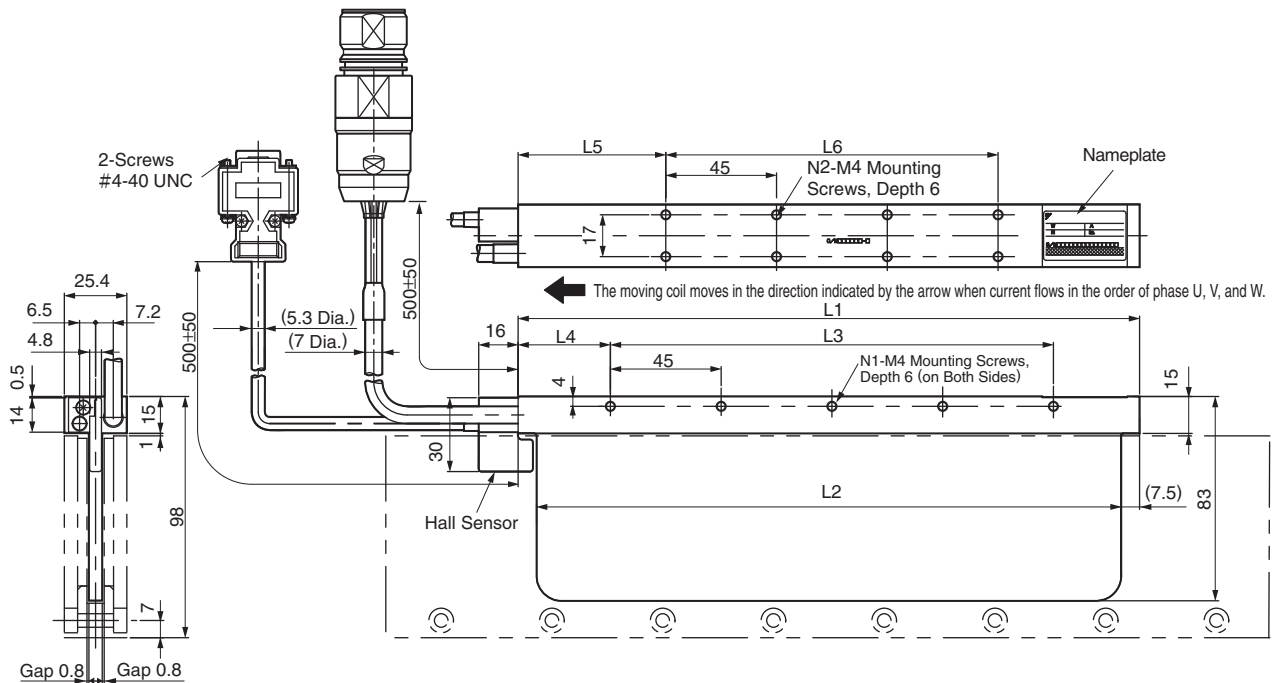

Hall Sensor Connector Specifications

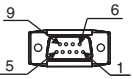

Pin Connector :
 17JE-23090-02 (D8C)
 by DDK Ltd.

The Mating Connector
 Socket Connector :
 17JE-13090-02 (D8C)
 Stud : 17L-002C or
 17L-002C1

Pin No.	Signal
1	+5V (Power supply)
2	Phase U
3	Phase V
4	Phase W
5	0V (Power supply)
6	Not used
7	Not used
8	Not used
9	Not used

Linear Servomotor Connector Specifications



Extension: SROC06JM5CN169
 Pin : 021.423.1020
 by Interconnectron GmbH

The Mating Connector
 Plug : SPUC06KFSDN236
 Socket: 020.030.1020

Pin No.	Signal	Wire Color
1	Phase U	Red
2	Phase V	White
3	Phase W	Blue
4	Not used	-
5	Not used	-
6	FG	Green

Hall Sensor Output Signals

When the moving coil moves in the direction indicated by the arrow in the figure, the relationship between the hall sensor output signals S_u , S_v , S_w and the inverse power of each motor phase V_u , V_v , V_w becomes as shown in the figure below.

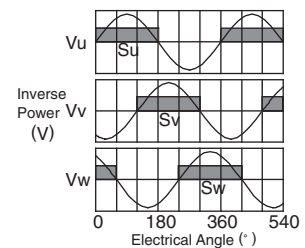

Moving Coil Model SGLGW-	L1	L2	L3	L4	L5	L6	N1	N2	Approx. Mass* kg
60A140C□D	140	125	90	30	52.5	45	3	4	0.48
60A253C□D	252.5	237.5	180	37.5	60	135	5	8	0.82
60A365C□D	365	350	315	30	52.5	270	8	14	1.16

*: The values indicate the mass of moving coil with a hall sensor unit.

External Dimensions Units: mm

- Magnetic Way : SGLGM-60□□□C (Without mounting holes on the bottom)
SGLGM-60□□□CT (With mounting holes on the bottom)

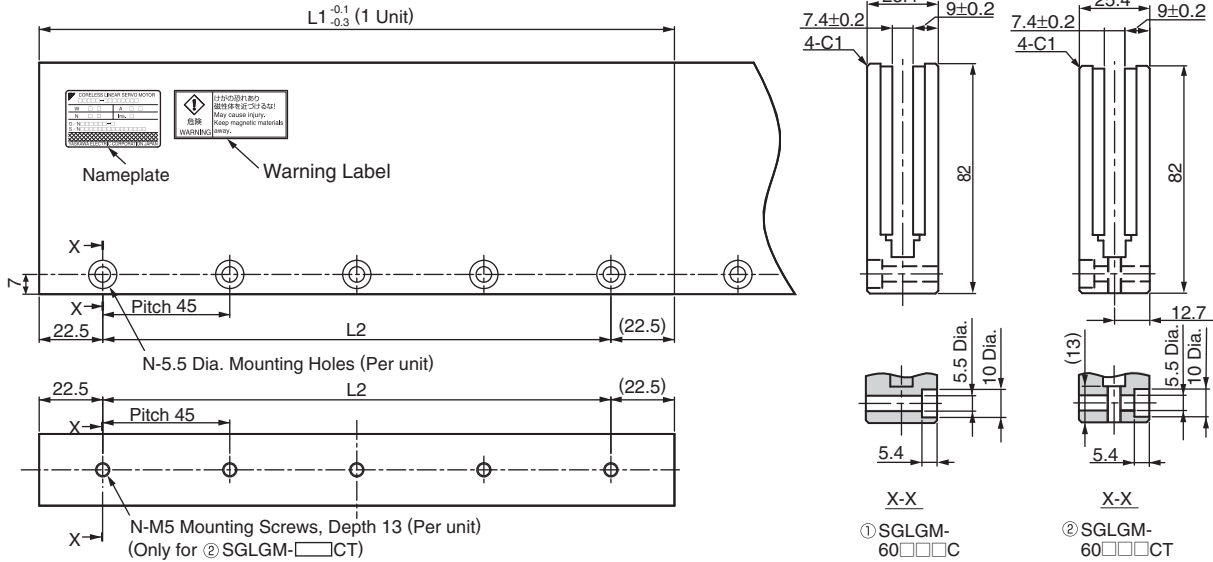

Type	Standard-force Magnetic Way Model SGLGM-	L1	L2	N	Approx. Mass kg
Standard Force	60090C or 60090CT	90	45	2	1.1
	60225C or 60225CT	225	180	5	2.6
	60360C or 60360CT	360	315	8	4.1
	60405C or 60405CT	405	360	9	4.6
	60450C or 60450CT	450	405	10	5.1

Note: If you have a pacemaker or any other electronic medical device, do not go near the magnetic way of the linear servomotor.

- High-force Magnetic Way : SGLGM-60□□□C-M (Without mounting holes on the bottom)
SGLGM-60□□□CT-M (With mounting holes on the bottom)

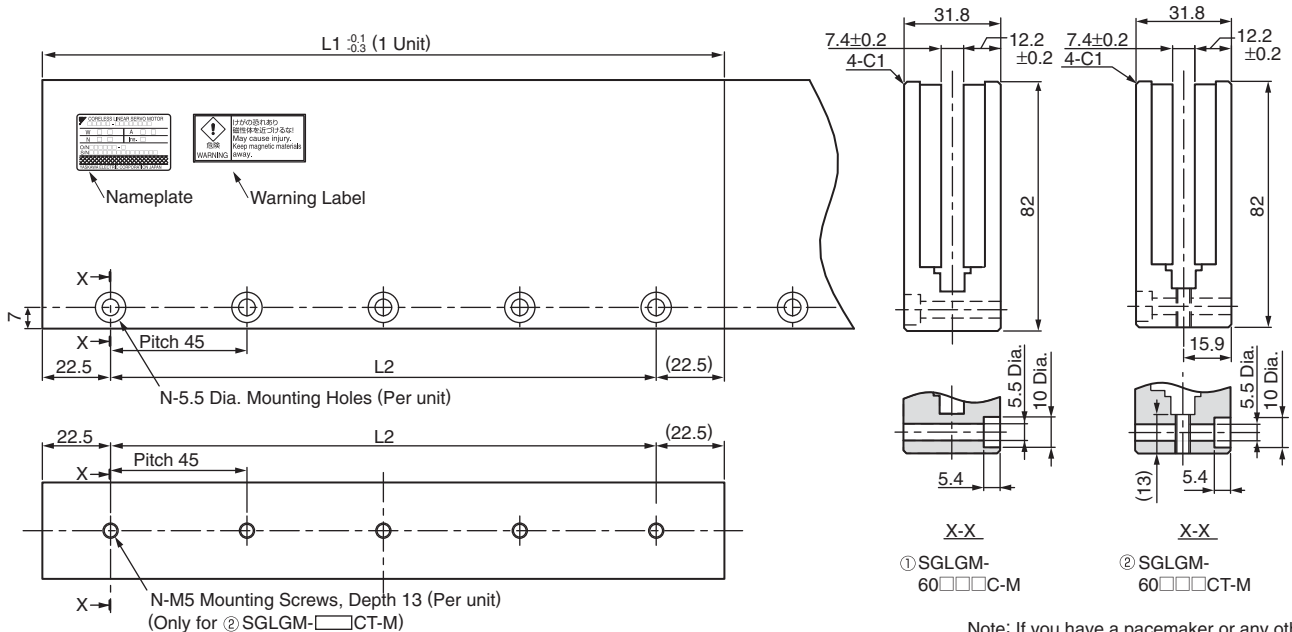

Type	High-force Magnetic Way Model SGLGM-	L1	L2	N	Approx. Mass kg
High Force	60090C-M or 60090CT-M	90	45	2	1.3
	60225C-M or 60225CT-M	225	180	5	3.3
	60360C-M or 60360CT-M	360	315	8	5.2
	60405C-M or 60405CT-M	405	360	9	5.9
	60450C-M or 60450CT-M	450	405	10	6.6

Note: If you have a pacemaker or any other electronic medical device, do not go near the magnetic way of the linear servomotor.

External Dimensions Units: mm

(4) SGLGW-90

- Moving Coil: SGLGW-90A□□□C□ (With a connector by Tyco Electronics AMP K.K.)

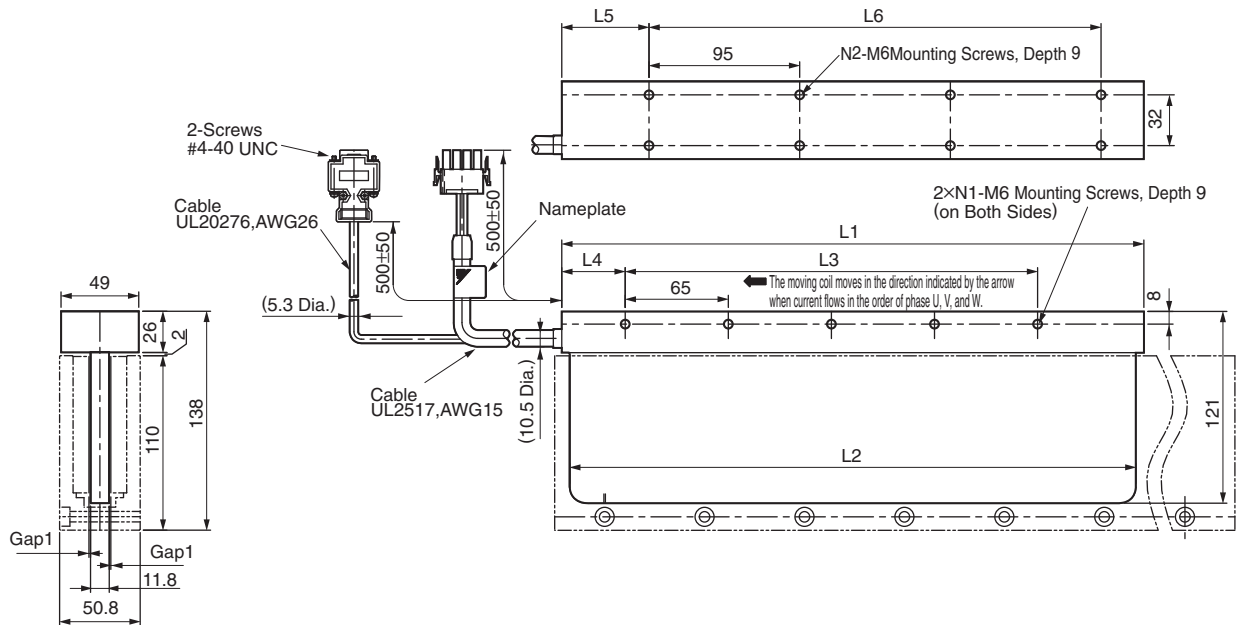

Hall Sensor Connector Specifications

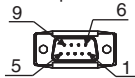

Pin Connector :
 17JE-23090-02 (D8C)
 by DDK Ltd.

The Mating Connector

Socket Connector :
 17JE-13090-02 (D8C)
 Stud : 17L-002C or
 17L-002C1

Pin No.	Signal
1	+5V (Power supply)
2	Phase U
3	Phase V
4	Phase W
5	0V (Power supply)
6	Not used
7	Not used
8	Not used
9	Not used

Linear Servomotor Connector Specifications

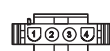

Plug : 350779-1
 Pin : 350218-3 or
 350547-3 (No.1 or 3)
 350654-1
 350669-1 (No.4)
 by Tyco Electronics AMP K.K.

The Mating Connector

Cap : 350780-1
 Socket : 350536-3 or
 350550-3

Pin No.	Signal	Wire Color
1	Phase U	Red
2	Phase V	White
3	Phase W	Blue
4	FG	Green

Hall Sensor Output Signals

When the moving coil moves in the direction indicated by the arrow in the figure, the relationship between the hall sensor output signals Su, Sv, Sw and the inverse power of each motor phase Vu, Vv, Vw becomes as shown in the figure below.

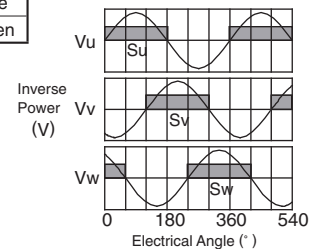

Moving Coil Model SGLGW-	L1	L2	L3	L4	L5	L6	N1	N2	Approx. Mass* kg
90A200C□	199	189	130	40	60	95	3	4	2.2
90A370C□	367	357	260	40	55	285	5	8	3.65
90A535C□	535	525	455	40	60	380	8	10	4.95

*: The values indicate the mass of moving coil with a hall sensor unit.

External Dimensions Units: mm

• Magnetic Way: SGLGM-90□□□A

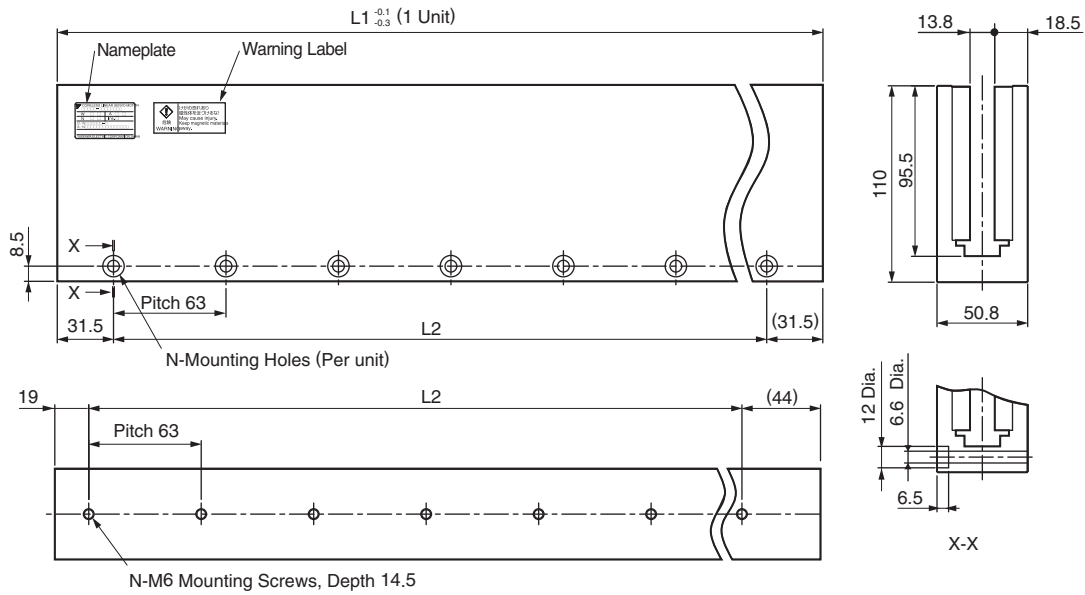

Note: If you have a pacemaker or any other electronic medical device, do not go near the magnetic way of the linear servomotor.

Magnetic Way SGLGM-	L1	L2	N	Approx. Mass kg
90252A	252	189	4	7.3
90504A	504	441	8	14.7

Selecting Cables

● Cables Connections

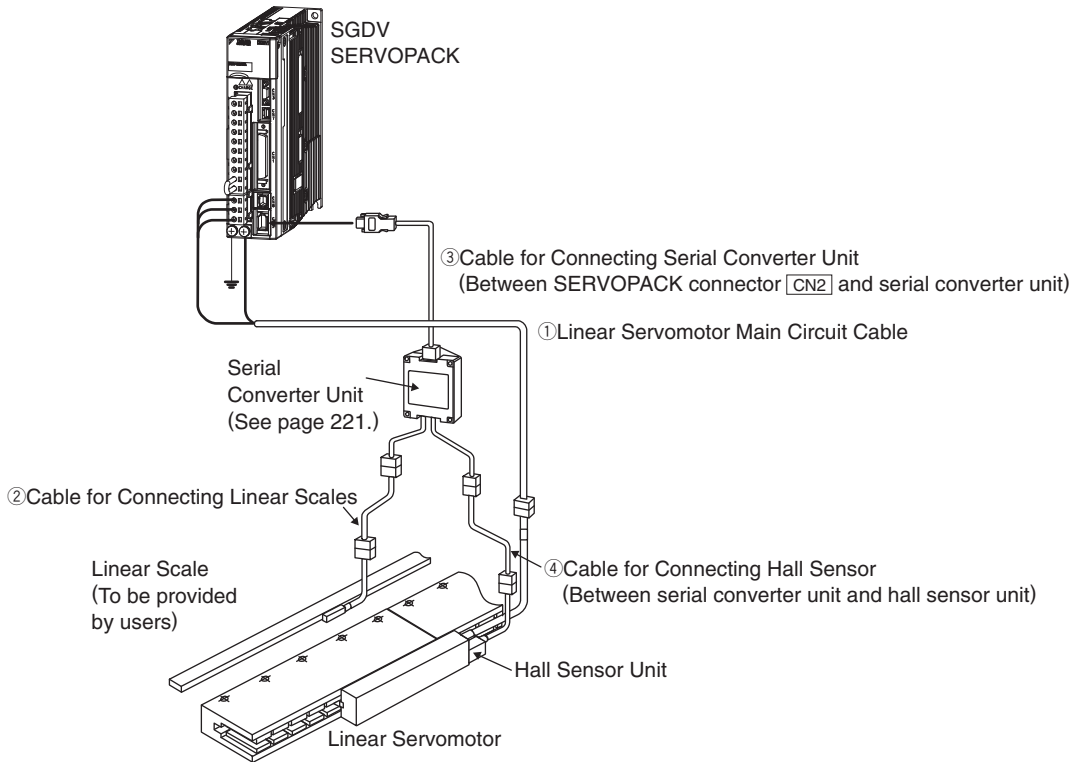

● Cables

Name	Applicable Linear Servomotor Model	Length	Order No.	Specifications	Details
① Linear Servomotor Main Circuit Cables	SGLGW-30, -40, -60	1 m	JZSP-CLN11-01-E		(1)
		3 m	JZSP-CLN11-03-E		
		5 m	JZSP-CLN11-05-E		
		10 m	JZSP-CLN11-10-E		
		15 m	JZSP-CLN11-15-E		
	20 m	JZSP-CLN11-20-E	*1		
	SGLGW-90	1 m	JZSP-CLN21-01-E		(2)
		3 m	JZSP-CLN21-03-E		
		5 m	JZSP-CLN21-05-E		
		10 m	JZSP-CLN21-10-E		
		15 m	JZSP-CLN21-15-E		
	20 m	JZSP-CLN21-20-E	*1		
	SGLGW -30□□□□□□D -40□□□□□□D -60□□□□□□D	1 m	JZSP-CLN14-01-E		(3)
		3 m	JZSP-CLN14-03-E		
		5 m	JZSP-CLN14-05-E		
10 m		JZSP-CLN14-10-E			
15 m		JZSP-CLN14-15-E			
20 m	JZSP-CLN14-20-E	*2			

*1: Connector by Tyco Electronics AMP K.K.
 *2: Connector by Interconnectron GmbH

(Cont'd)

Selecting Cables

● Cables

Name	Applicable Linear Servomotor Model	Length	Order No.	Specifications	Details
② Cables for Connecting Linear Scales*	All models	1 m	JZSP-CLL00-01-E		(4)
		3 m	JZSP-CLL00-03-E		
		5 m	JZSP-CLL00-05-E		
		10 m	JZSP-CLL00-10-E		
		15 m	JZSP-CLL00-15-E		
③ Cables for Connecting Serial Converter Units	All models	1 m	JZSP-CLP70-01-E		(5)
		3 m	JZSP-CLP70-03-E		
		5 m	JZSP-CLP70-05-E		
		10 m	JZSP-CLP70-10-E		
		15 m	JZSP-CLP70-15-E		
		20 m	JZSP-CLP70-20-E		
④ Cables for Connecting Hall Sensors	All models	1 m	JZSP-CLL10-01-E		(6)
		3 m	JZSP-CLL10-03-E		
		5 m	JZSP-CLL10-05-E		
		10 m	JZSP-CLL10-10-E		
		15 m	JZSP-CLL10-15-E		

*: When using serial converter unit JZDP-G00□-□□□-E, the maximum cable length should be 3 m.

(1) Linear Servomotor Main Circuit Cables: JZSP-CLN11-□□-E

· Wiring Specifications

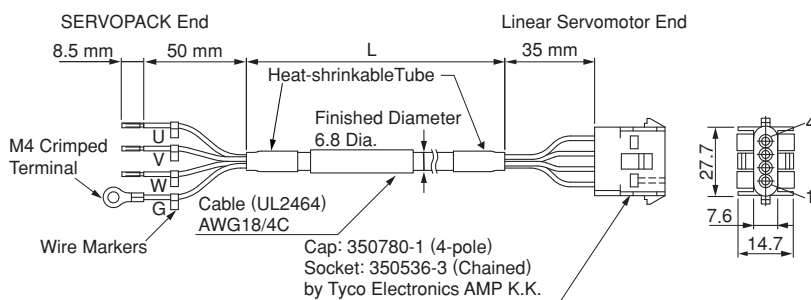

SERVOPACK-end Leads		Linear Servomotor-end Connector	
Wire Color	Signal	Signal	Pin No.
Red	Phase U	Phase U	1
White	Phase V	Phase V	2
Blue	Phase W	Phase W	3
Green/yellow	FG	FG	4

(2) Linear Servomotor Main Circuit Cables: JZSP-CLN21-□□-E

· Wiring Specifications

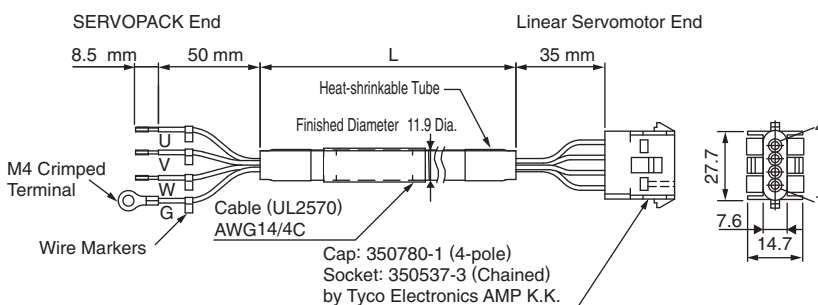

SERVOPACK-end Leads		Linear Servomotor-end Connector	
Wire Color	Signal	Signal	Pin No.
Red	Phase U	Phase U	1
White	Phase V	Phase V	2
Blue	Phase W	Phase W	3
Green/yellow	FG	FG	4

(3) Linear Servomotor Main Circuit Cables: JZSP-CLN14-□□-E

· Wiring Specifications

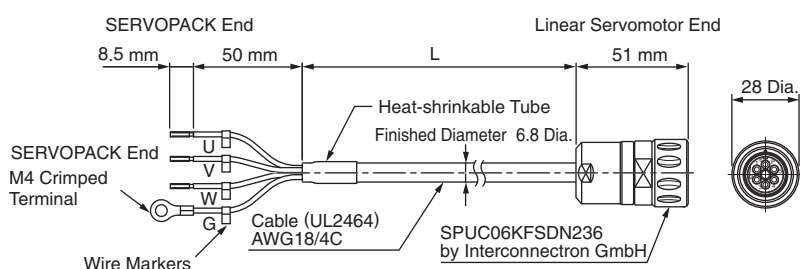

SERVOPACK-end Leads		Linear Servomotor-end Connector	
Wire Color	Signal	Signal	Pin No.
Black (White 1)	Phase U	Phase U	1
Black (White 2)	Phase V	Phase V	2
Black (White 3)	Phase W	Phase W	3
Green/yellow	FG	—	4
		—	5
		FG	6

Selecting Cables

(4) Cables for Connecting Linear Scales: JZSP-CLL00-□□-E

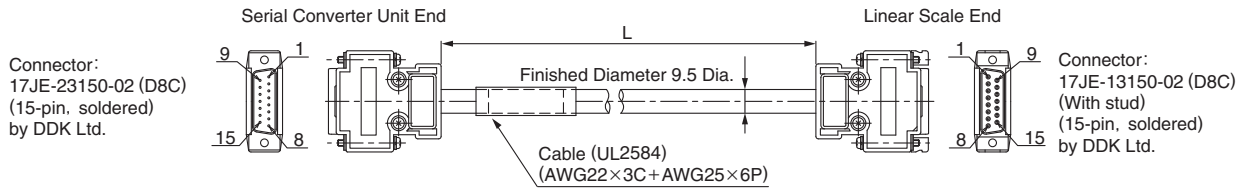

• Wiring Specifications

Serial Converter Unit End		Linear Scale End	
Pin No.	Signal	Pin No.	Signal
1	/Cos (V1-)	1	/Cos (V1-)
2	/Sin (V2-)	2	/Sin (V2-)
3	Ref (V0+)	3	Ref (V0+)
4	+5V	4	+5V
5	5Vs	5	5Vs
6	BID	6	BID
7	Vx	7	Vx
8	Vq	8	Vq
9	Cos (V1+)	9	Cos (V1+)
10	Sin (V2+)	10	Sin (V2+)
11	/Ref (V0-)	11	/Ref (V0-)
12	0V	12	0V
13	0Vs	13	0Vs
14	DIR	14	DIR
15	Inner	15	Inner
Case	Shield	Case	Shield

(5) Cables for Connecting Serial Converter Units: JZSP-CLP70-□□-E

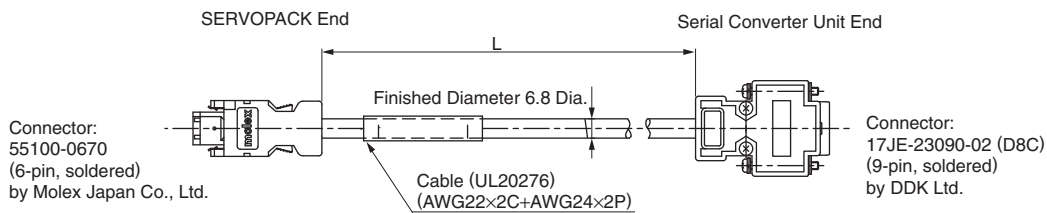

• Wiring Specifications

SERVOPACK End			Serial Converter Unit End		
Pin No.	Signal	Wire Color	Pin No.	Signal	Wire Color
1	PG5V	Red	1	+5V	Red
2	PG0V	Black	5	0V	Black
3	-	-	3	-	-
4	-	-	4	-	-
5	PS	Light blue	2	Phase S output	Light blue
6	/PS	Light blue/white	6	Phase /S output	Light blue/white
Shell	Shield	-	Case	Shield	-
			7	-	-
			8	-	-
			9	-	-

(6) Cables for Connecting Hall Sensors: JZSP-CLL10-□□-E

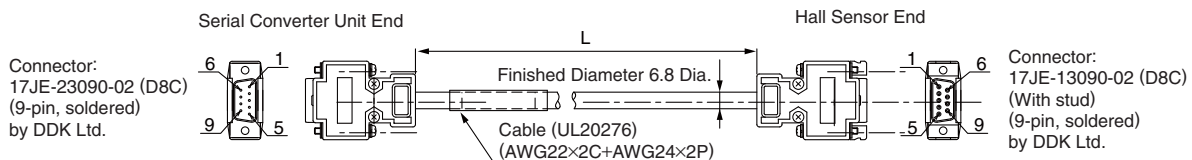

• Wiring Specifications

Serial Converter Unit End		Hall Sensor End	
Pin No.	Signal	Pin No.	Signal
1	+5V	1	+5V
2	Phase U input	2	Phase U input
3	Phase V input	3	Phase V input
4	Phase W input	4	Phase W input
5	0V	5	0V
6	-	6	-
7	-	7	-
8	-	8	-
9	-	9	-
Case	Shield	Case	Shield

Linear Servomotors

SGLFW

(With F-type iron core)

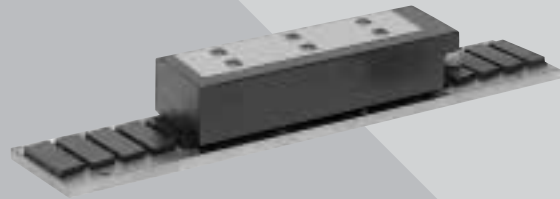

Model Designations

• Moving Coil

SGL F W - 20 A 090 A P □

Linear Σ Series
Linear Servomotor
Servomotor Type

Code	Specifications
F	F-type iron core

W: Moving Coil
Magnet Height
Voltage
A: 200 VAC
D: 400 VAC
Length of Moving Coil

Connector for Main Circuit Cable

Code	Specifications	Applicable Model
Blank	Connector by Tyco Electronics AMP K.K.	All models
D	Connector by Interconnectron GmbH	SGLFW-35, -50, -1Z□200B, -1ZD380B

Hall Sensor

Code	Specifications
P	With hall sensor
Blank	Without hall sensor

Design Revision Order
A, B, ...

• Magnetic Way

SGL F M - 20 324 A □

Linear Σ Series
Linear Servomotor
Servomotor Type

Code	Specifications
F	F-type iron core

M: Magnetic Way
Magnet Height

Options

Code	Specifications
Blank	Standard
C	With magnet cover

Design Revision Order
A, B, ...
Length of Magnetic Way

Features

- Direct-feed mechanism for high-speed and high-precision positioning.
- The magnetic attraction force between the moving and stationary members can be used effectively to increase the rigidity of the linear guidance by preloading the linear motion bearings.
- The magnetic preloading on certain types of compliant linear motion bearings can help increase the system's frequency response, improving its deceleration and settling performances.

Application Examples

- Feeders and loaders
- Semiconductor equipment
- LCD manufacturing equipment

● Precautions on Moving Coil with Hall Sensor

When using a moving coil with a hall sensor, the magnetic way must completely cover the bottom of the hall sensor. Refer to the example showing the correct installation.

When determining the length of the moving coil's stroke or the length of the magnetic way, consider the total length of the moving coil and the hall sensor unit. Refer to the following table.

< Correct >

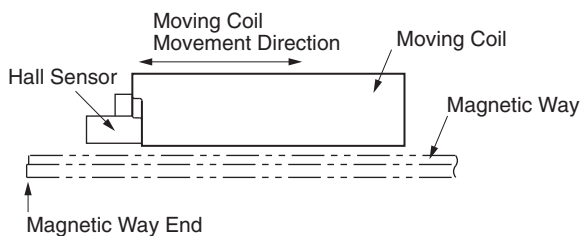

< Incorrect >

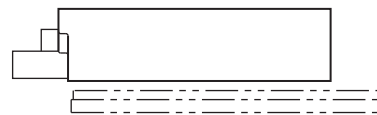

The total length of moving coil with hall sensor

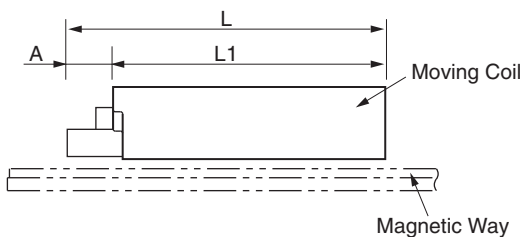

Moving Coil Model SGLFW-	Length of Moving Coil L1 (mm)	Length of Hall Sensor Unit A (mm)	Total Length L (mm)
20A090AP□	91	22	113
20A120AP□	127		149
35□120AP□	127	22	149
35□230AP□	235		257
50□200□P□	215	22	237
50□380□P□	395		417
1Z□200□P□	215	22	237
1Z□380□P□	395		417

Ratings and Specifications

Time Rating: Continuous

Insulation Resistance: 500 VDC, 10 MΩ min.

Ambient Temperature: 0 to 40°C

Excitation: Permanent magnet

Withstand Voltage: 1500 VAC for one minute

Enclosure: Self-cooled

Ambient Humidity: 20% to 80% (no condensation)

Allowable Winding Temperature: 130°C (Thermal class B)

200-V Class

Linear Servomotor Model SGLFW- 		20A		35A		50A		1ZA	
		090A	120A	120A	230A	200B	380B	200B	380B
Peak Speed	m/s	5.0	5.0	5.0	5.0	5.0	5.0	4.9	4.9
Rated Force*	N	25	40	80	160	280	560	560	1120
Rated Current*	Arms	0.70	0.80	1.4	2.8	5.0	10.0	8.7	17.5
Peak Force*	N	86	125	220	440	600	1200	1200	2400
Peak Current*	Arms	3.0	2.9	4.4	8.8	12.4	25.0	21.6	43.6
Moving Coil Mass	kg	0.7	0.9	1.3	2.3	3.5	6.9	6.4	11.5
Force Constant	N/Arms	36.0	54.0	62.4	62.4	60.2	60.2	69.0	69.0
BEMF Constant	V/ (m/s)	12.0	18.0	20.8	20.8	20.1	20.1	23.0	23.0
Motor Constant	N/√w	7.9	9.8	14.4	20.4	34.3	48.5	52.4	74.0
Electrical Time Constant	ms	3.2	3.3	3.6	3.6	15.9	15.8	18.3	18.3
Mechanical Time Constant	ms	11.0	9.3	6.2	5.5	3.0	2.9	2.3	2.1
Thermal Resistance (With Heat Sink)	K/W	4.35	3.19	1.57	0.96	0.56	0.38	0.47	0.2
Thermal Resistance (Without Heat Sink)	K/W	7.69	5.02	4.10	1.94	1.65	0.95	1.3	0.73
Magnetic Attraction	N	314	462	809	1590	1650	3260	3300	6520
Applicable SERVOPACK	SGDV-	1R6	1R6	1R6	3R8	5R5	120A	120A	200A

Notes: 1 The items marked with an * and *Force and Speed Characteristics* (the table on the next page) are the values at a motor winding temperature of 100°C during operation in combination with a SERVOPACK. The others are at 20°C.

2 The above specifications show the values under the cooling condition when a heat sink (aluminum board) listed in the following table is mounted on the moving coil.

Heat Sink Size	Model
125 mm×125 mm×13 mm	SGLFW-20A090A, -20A120A
254 mm×254 mm×25 mm	SGLFW-35A120A, -35A230A
400 mm×500 mm×40 mm	SGLFW-50A200B, -50A380B, -1ZA200B
600 mm×762 mm×50 mm	SGLFW-1ZA380B

400-V Class

Linear Servomotor Model SGLFW- 		35D		50D		1ZD	
		120A	230A	200B	380B	200B	380B
Peak Speed	m/s	4.5	4.5	5.0	5.0	5.0	5.0
Rated Force*	N	80	160	280	560	560	1120
Rated Current*	Arms	0.6	1.3	2.3	4.5	4.9	9.8
Peak Force*	N	220	440	600	1200	1200	2400
Peak Current*	Arms	2.0	4.0	5.6	11.0	12.3	24.6
Moving Coil Mass	kg	1.3	2.3	3.5	6.9	6.4	11.5
Force Constant	N/Arms	136.0	136.0	134.7	134.7	122.6	122.6
BEMF Constant	V/ (m/s)	45.3	45.3	44.9	44.9	40.9	40.9
Motor Constant	N/√w	14.2	20.1	33.4	47.2	51.0	72.1
Electrical Time Constant	ms	3.7	3.6	15.0	15.0	17.4	17.2
Mechanical Time Constant	ms	5.2	5.1	3.2	3.2	2.5	2.2
Thermal Resistance (With Heat Sink)	K/W	1.57	0.96	0.56	0.38	0.47	0.2
Thermal Resistance (Without Heat Sink)	K/W	4.1	1.94	1.65	0.95	1.3	0.73
Magnetic Attraction	N	810	1590	1650	3260	3300	6520
Applicable SERVOPACK	SGDV-	1R9D	1R9D	3R5D	5R4D	5R4D	120D

Notes: 1 The items marked with an * and *Force and Speed Characteristics* (the table on the next page) are the values at a motor winding temperature of 100°C during operation in combination with a SERVOPACK. The others are at 20°C.

2 The above specifications show the values under the cooling condition when a heat sink (aluminum board) listed in the following table is mounted on the moving coil.

Heat Sink Size	Model
254 mm×254 mm×25 mm	SGLFW-35D120A, -35D230A
400 mm×500 mm×40 mm	SGLFW-50D200B, -50D380B, -1ZD200B
600 mm×762 mm×50 mm	SGLFW-1ZD380B

Ratings and Specifications

- **Force and Speed Characteristics** **A** : Continuous Duty Zone **B** : Intermittent Duty Zone ^(Note1)
 200-V Class

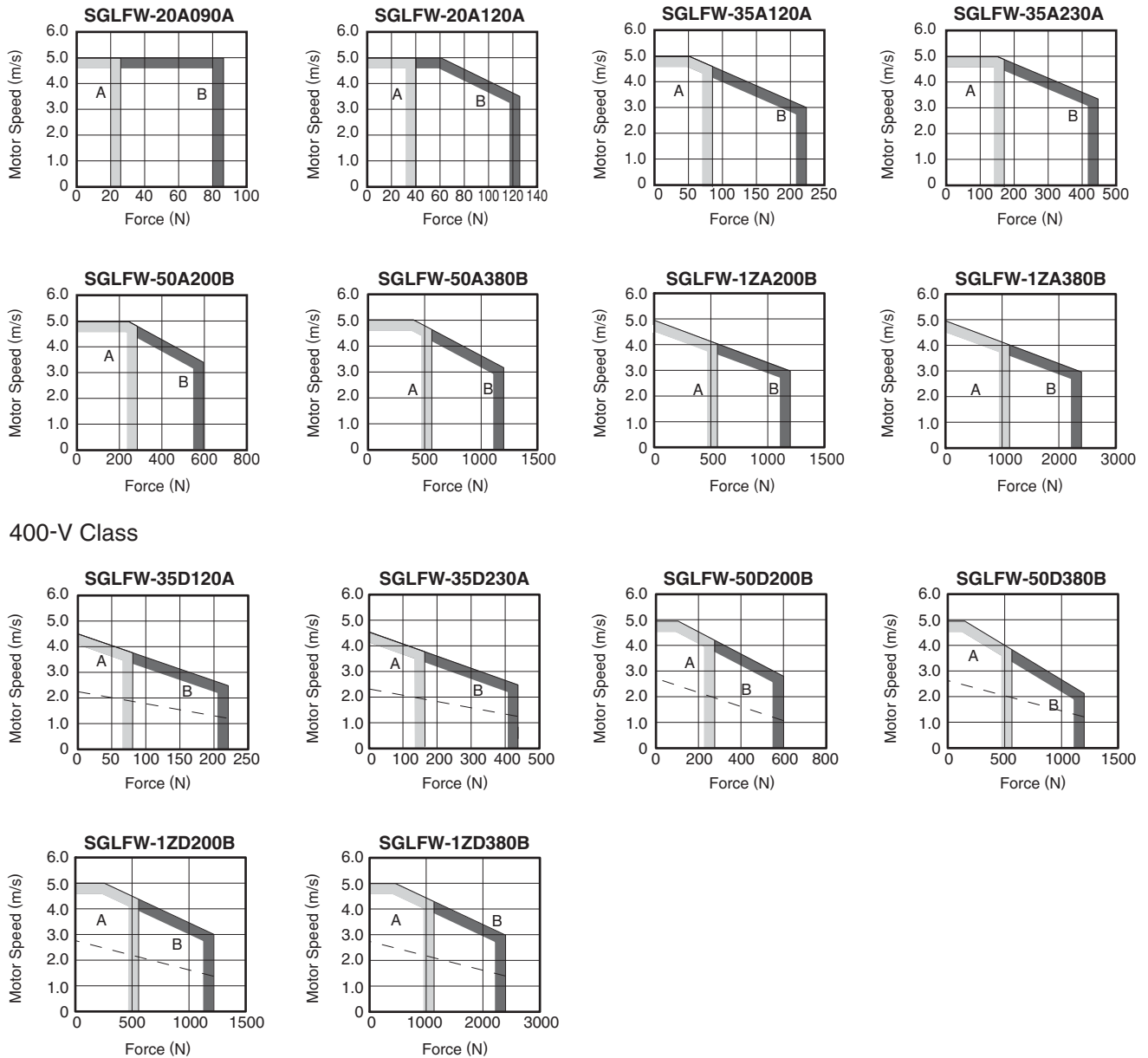

Notes: 1 When the effective force during intermittent duty is within the rated force, the servomotor can be used within the intermittent duty zone.
 2 The dotted line indicates the characteristics when a 400-VAC linear servomotor is used with 200-V input power supply. In this case, a serial converter unit is required. Contact your Yaskawa representative for details.

- **Mechanical Specifications**

- (1) Impact Resistance

- Impact acceleration: 196 m/s²
- Impact occurrences: twice

- (2) Vibration Resistance

The linear servomotors will withstand the following vibration acceleration in three directions: Vertical, side to side, and front to back.

- Vibration acceleration: 49 m/s²

External Dimensions Units: mm

(1) SGLFW-20

- Moving Coil: SGLFW-20A□□□A□ (With a connector by Tyco Electronics AMP K.K.)

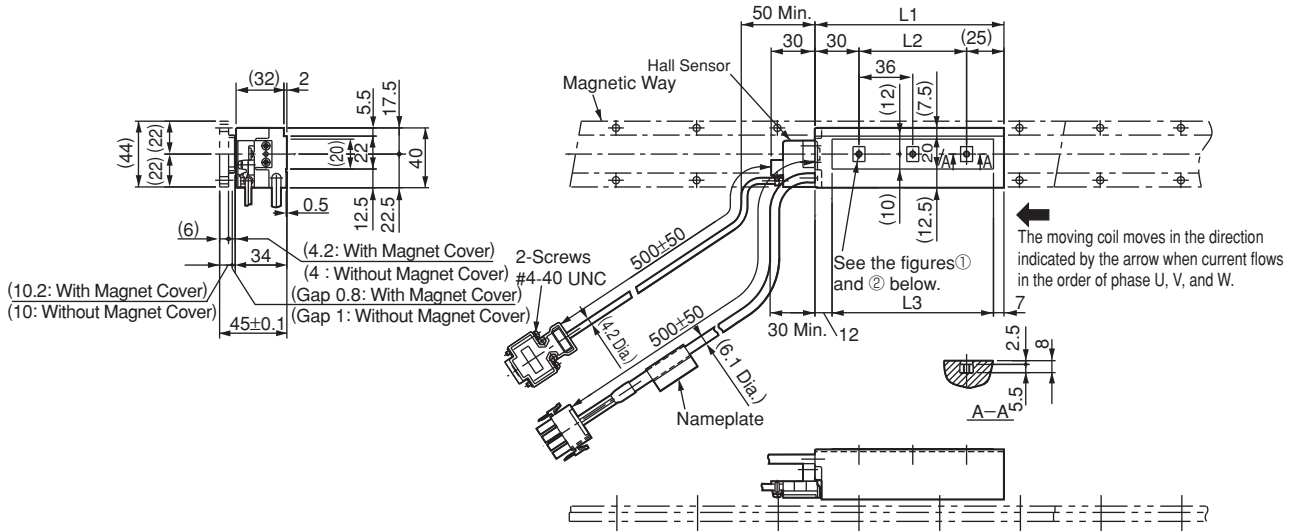

① SGLFW-20A090A□

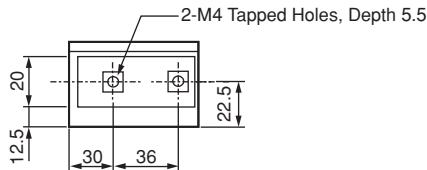

② SGLFW-20A120A□

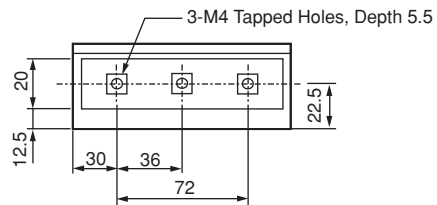

Hall Sensor Connector Specifications

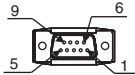

Pin Connector :
17JE-13090-02 (D8C)
by DDK Ltd.

The Mating Connector

Socket Connector:
17JE-13090-02 (D8C)
Stud: 17L-002C or
17L-002C1

Pin No.	Signal
1	+5V (Power supply)
2	Phase U
3	Phase V
4	Phase W
5	0V (Power supply)
6	Not used
7	Not used
8	Not used
9	Not used

Linear Servomotor Connector Specifications



Plug:350779-1
Pin :350218-3 or
350547-3(No.1 to 3)
350654-1
350669-1(No.4)
by Tyco Electronics AMP K.K.

The Mating Connector

Cap : 350780-1
Socket: 350536-3 or
350550-3

Note: Models compatible with connectors by Interconnecton GmbH are also available.

Hall Sensor Output Signals

When the moving coil moves in the direction indicated by the arrow in the figure, the relationship between the hall sensor output signals S_u , S_v , S_w and the inverse power of each motor phase V_u , V_v , V_w becomes as shown in the figure below.

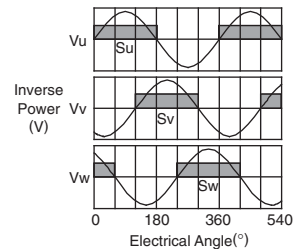

Moving Coil Model SGLFW-	L1	L2	L3	Approx. Mass kg
20A090A□	91	36	72	0.7
20A120A□	127	72	108	0.9

External Dimensions Units: mm

- Magnetic Way: SGLFM-20□□□A

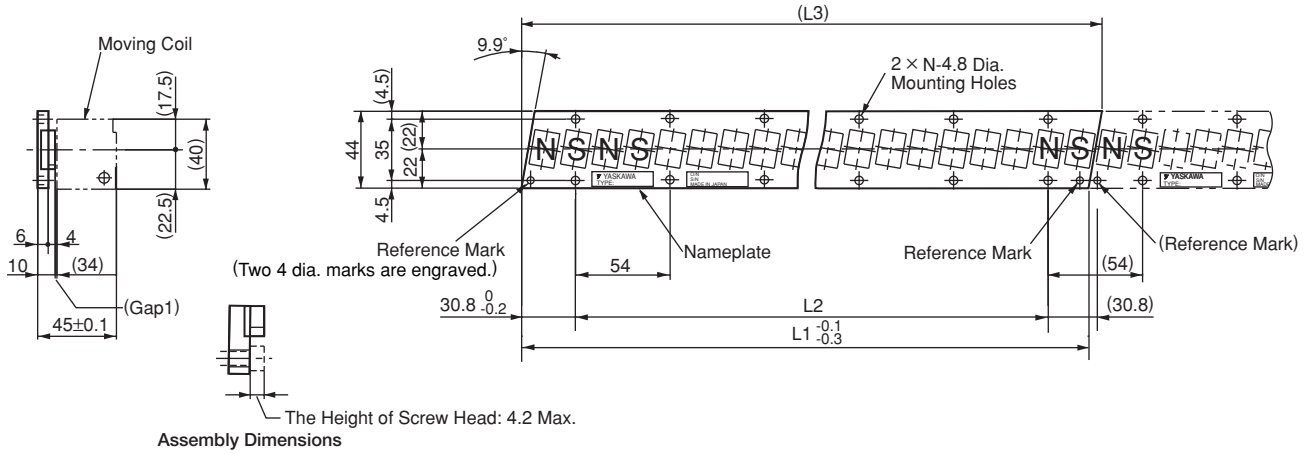

Notes: 1 Multiple SGLFM-20□□□A magnetic ways can be connected. Connect magnetic ways so that the reference marks match one on the other in the same direction as shown in the figure.
 2 If you have a pacemaker or any other electronic medical device, do not go near the magnetic way of the linear servomotor.

Magnetic Way Model SGLFM-	L1 ^{-0.1} _{-0.3}	L2	(L3)	N	Approx. Mass kg
20324A	324	270 (54×5)	(331.6)	6	0.9
20540A	540	486 (54×9)	(547.6)	10	1.4
20756A	756	702 (54×13)	(763.6)	14	2

External Dimensions Units: mm

(2) SGLFW-35

- Moving Coil: SGLFW-35□□□□A□ (With a connector by Tyco Electronics AMP K.K.)

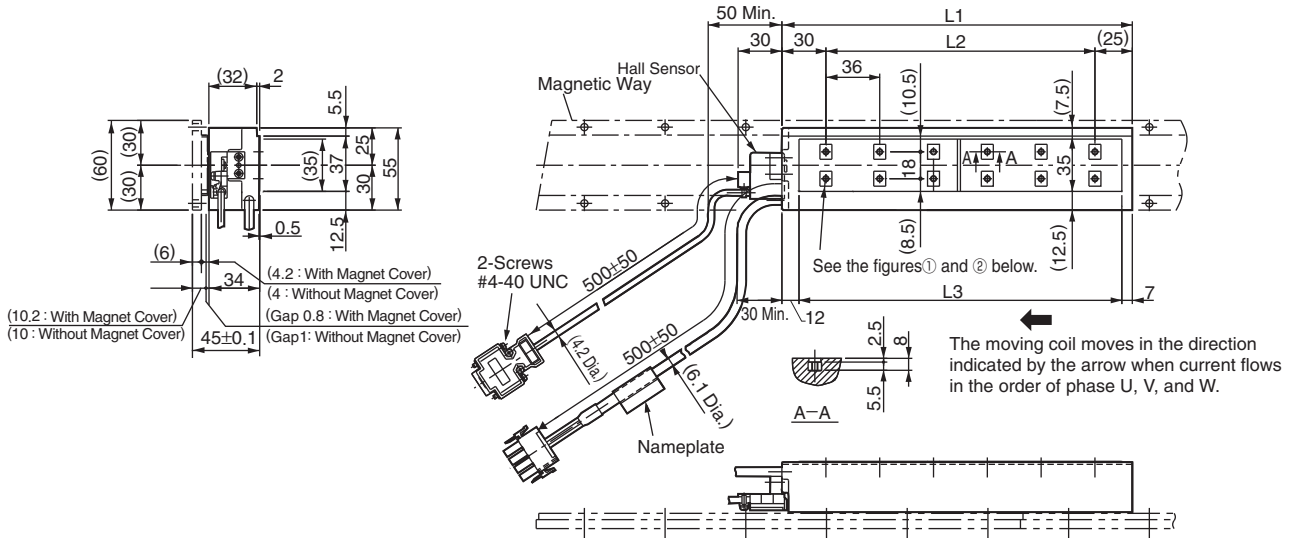

① SGLFW-35□120A□

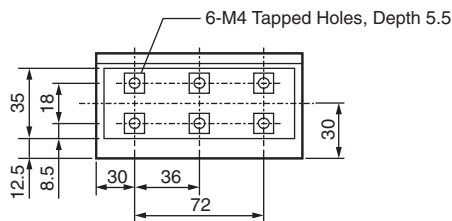

② SGLFW-35□230A□

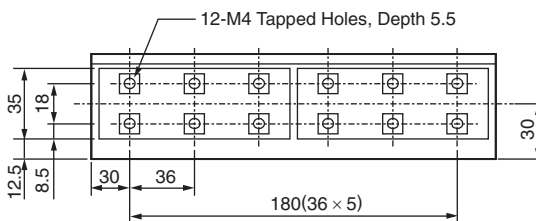

Hall Sensor Connector Specifications

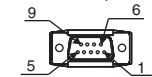

Pin Connector
17JE-23090-02 (D8C)
by DDK Ltd.

The Mating Connector

Socket Connector:
17JE-13090-02(D8C)
Stud:17L-002C or
17L-002C1

Pin No.	Signal
1	+5V (Power supply)
2	Phase U
3	Phase V
4	Phase W
5	0V (Power supply)
6	Not used
7	Not used
8	Not used
9	Not used

Linear Servomotor Connector Specifications

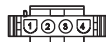

Plug: 350779-1
Pin : 350218-3 or
350547-3 (No.1 to 3)
350654-1
350669-1 (No.4)
by Tyco Electronics AMP K.K.

The Mating Connector

Cap : 350780-1
Socket: 350536-3 or
350550-3

Pin No.	Signal	Wire Color
1	Phase U	Red
2	Phase V	White
3	Phase W	Black
4	FG	Green

Hall Sensor Output Signals

When the moving coil moves in the direction indicated by the arrow in the figure, the relationship between the hall sensor output signals S_u , S_v , S_w and the inverse power of each motor phase V_u , V_v , V_w becomes as shown in the figure below.

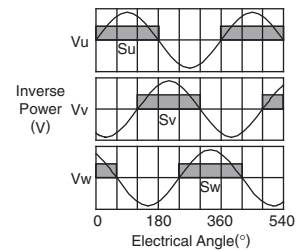

Moving Coil Model SGLFW-	L1	L2	L3	Approx. Mass kg
35□120A□	127	72	108	1.3
35□230A□	235	180	216	2.3

External Dimensions Units: mm

- Moving Coil: SGLFW-35□□□□A□D (With a connector by Interconnectron GmbH)

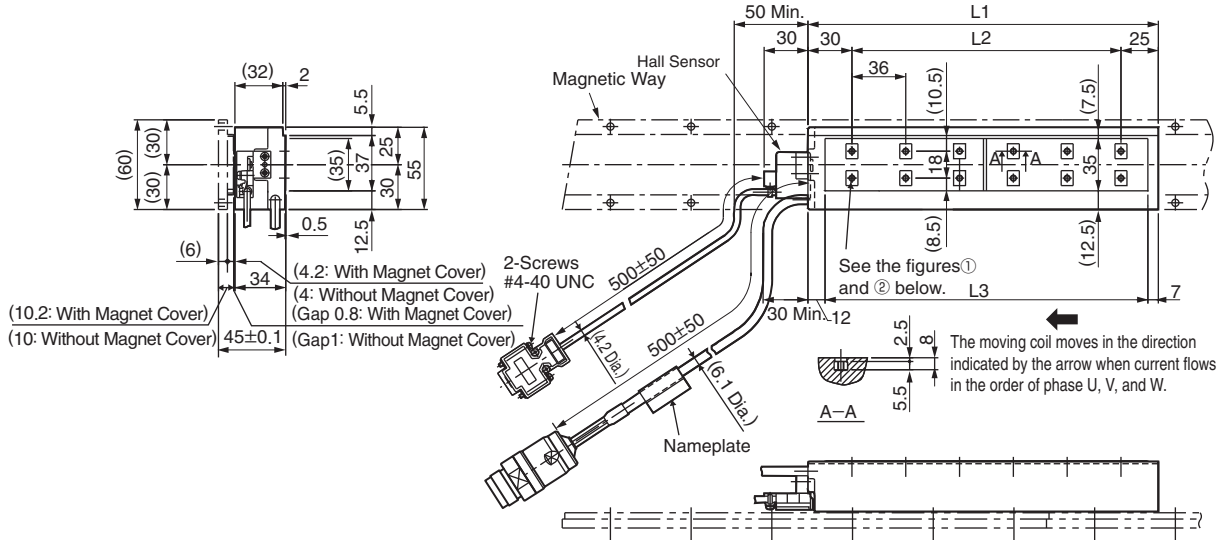

① SGLFW-35□120A□D

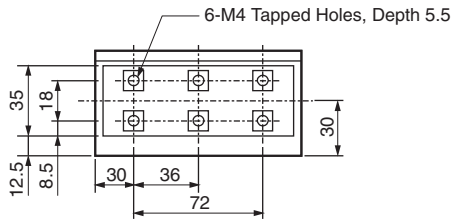

② SGLFW-35□230A□D

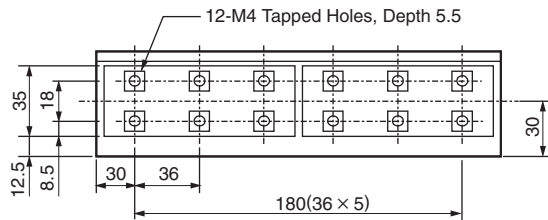

Hall Sensor Connector Specifications

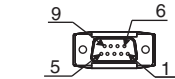

Pin Connector : 17JE-23090-02 (D8C) by DDK Ltd.

The Mating Connector

Socket Connector: 17JE-13090-02 (D8C) Stud: 17L-002C or 17L-002C1

Pin No.	Signal
1	+5V (Power supply)
2	Phase U
3	Phase V
4	Phase W
5	0V (Power supply)
6	Not used
7	Not used
8	Not used
9	Not used

Linear Servomotor Connector Specifications



Extension: ARRA06AMRPN182 Pin : 021.279.1020 by Interconnectron GmbH

The Mating Connector

Plug : APRA06BFRDN170 Socket: 020.105.1020

Pin No.	Name
1	Phase U
2	Phase V
4	Phase W
5	Not used
6	Not used
⊕	Ground

Hall Sensor Output Signals

When the moving coil moves in the direction indicated by the arrow in the figure, the relationship between the hall sensor output signals S_u , S_v , S_w and the inverse power of each motor phase V_u , V_v , V_w becomes as shown in the figure below.

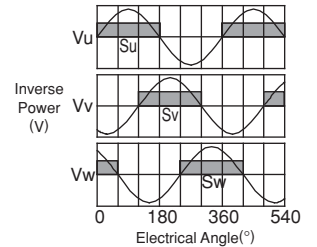

Moving Coil Model SGLFW-	L1	L2	L3	N	Approx. Mass kg
35□120A□D	127	72	108	6	1.3
35□230A□D	235	180	216	12	2.3

External Dimensions Units: mm

• Magnetic Way: SGLFM-35□□□A

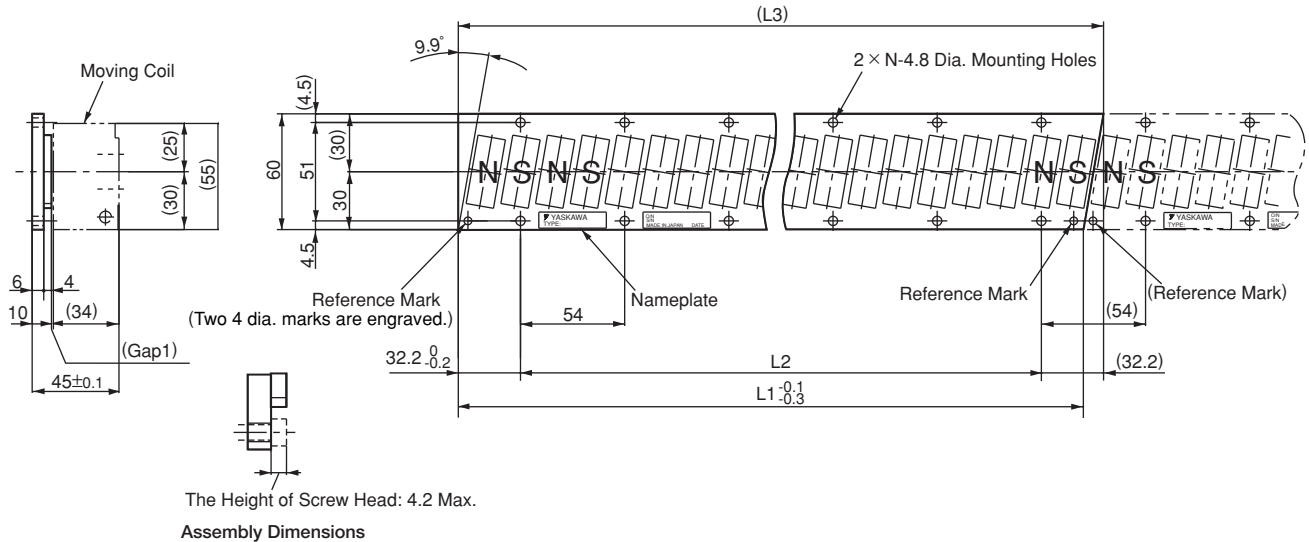

- Notes: 1 Multiple SGLFM-35□□□A magnetic ways can be connected. Connect magnetic ways so that the reference marks match one on the other in the same direction as shown in the figure.
 2 If you have a pacemaker or any other electronic medical device, do not go near the magnetic way of the linear servomotor.

Magnetic Way Model SGLFM-	L1 _{0.3} ^{0.1}	L2	(L3)	N	Approx. Mass kg
35324A	324	270 (54×5)	(334.4)	6	1.2
35540A	540	486 (54×9)	(550.4)	10	2
35756A	756	702 (54×13)	(766.4)	14	2.9

External Dimensions Units: mm

(3) SGLFW-50

- Moving Coil: SGLFW-50□□□□B□ (With a connector by Tyco Electronics AMP K.K.)

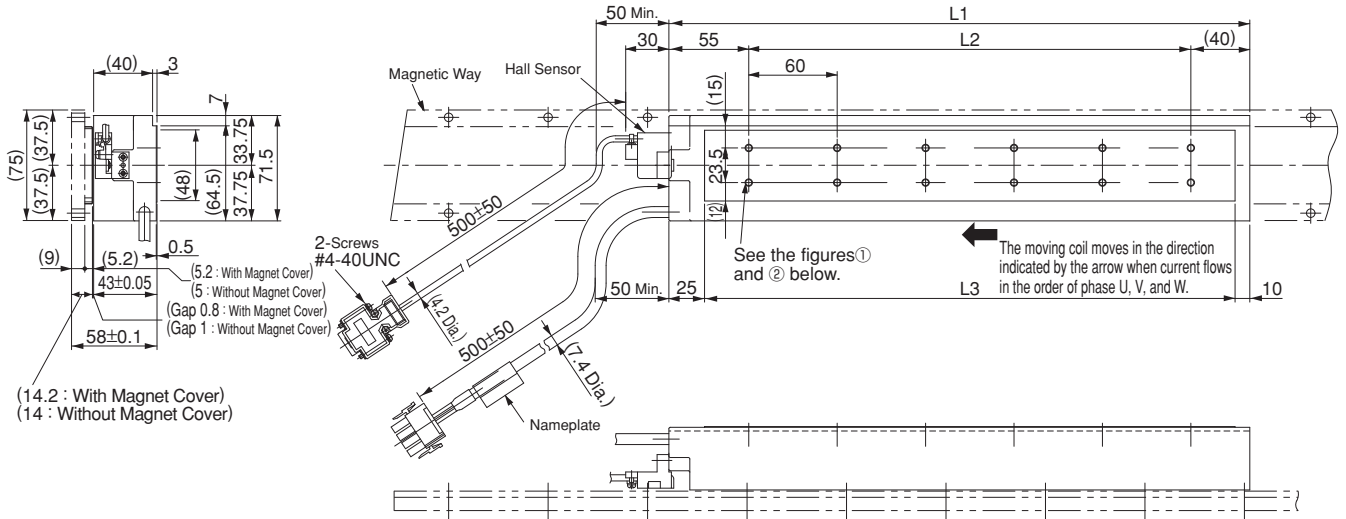

① SGLFW-50□200B□

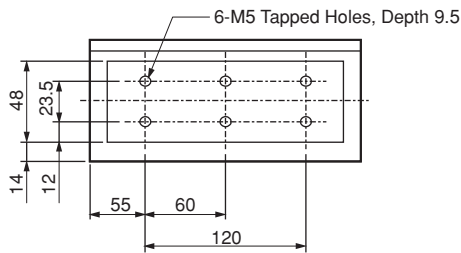

② SGLFW-50□380B□

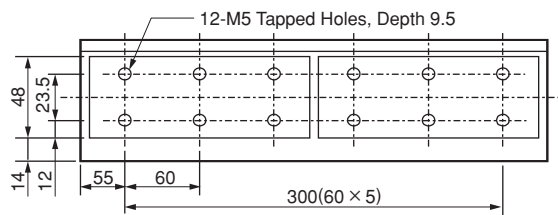

Hall Sensor Connector Specifications

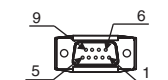

Pin Connector :
 17JE-23090-02 (D8C)
 by DDK Ltd.

The Mating Connector

Socket Connector:
 17JE-13090-02 (D8C)
 Stud: 17L-002C or
 17L-002C1

Pin No.	Signal
1	+5V (Power supply)
2	Phase U
3	Phase V
4	Phase W
5	0V (Power supply)
6	Not used
7	Not used
8	Not used
9	Not used

Linear Servomotor Connector Specifications



Plug: 350779-1
 Pin : 350218-3 or
 350547-3 (No.1 to 3)
 350654-1
 350669-1 (No.4)
 by Tyco Electronics AMP K.K.

The Mating Connector

Cap : 350780-1
 Socket: 350536-3 or
 350550-3

Pin No.	Signal	Wire Color
1	Phase U	Red
2	Phase V	White
3	Phase W	Black
4	FG	Green

Hall Sensor Output Signals

When the moving coil moves in the direction indicated by the arrow in the figure, the relationship between the hall sensor output signals S_u , S_v , S_w and the inverse power of each motor phase V_u , V_v , V_w becomes as shown in the figure below.

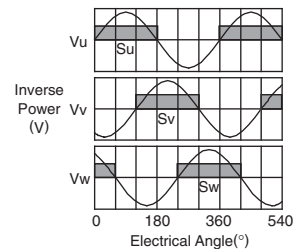

Moving Coil Model SGLFW-	L1	L2	L3	Approx. Mass kg
50□200B□	215	120	180	3.5
50□380B□	395	300	360	6.9

External Dimensions Units: mm

- Moving Coil: SGLFW-50□□□□B□D (With a connector by Interconnectron GmbH)

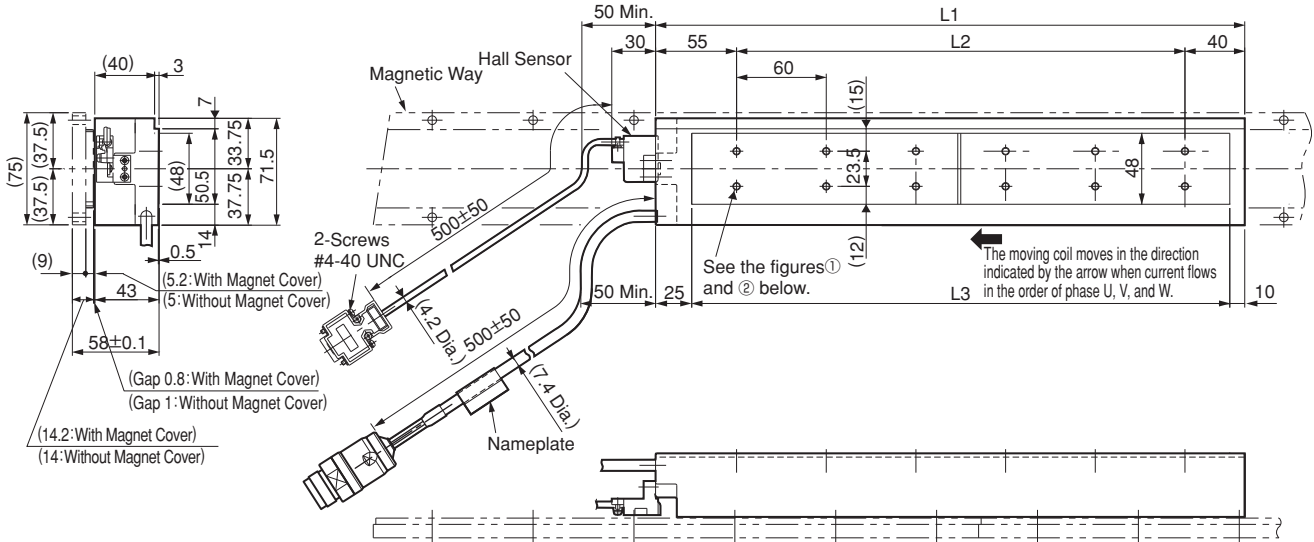

① SGLFW-50□200B□D

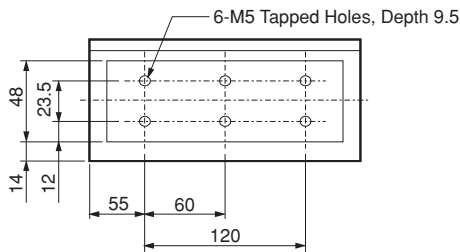

② SGLFW-50□380B□D

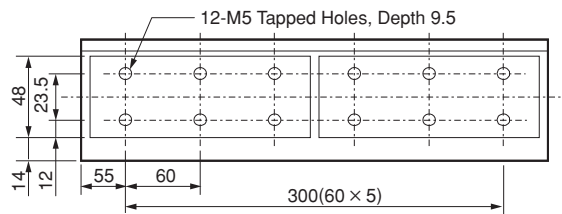

Hall Sensor Connector Specifications

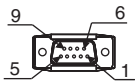

Pin Connector :
17JE-23090-02 (D8C)
by DDK Ltd.

The Mating Connector

Socket Connector:
17JE-13090-02 (D8C)
Stud: 17L-002C or
17L-002C1

Pin No.	Signal
1	+5V (Power supply)
2	Phase U
3	Phase V
4	Phase W
5	0V (Power supply)
6	Not used
7	Not used
8	Not used
9	Not used

Linear Servomotor Connector Specifications



Extension: ARRA06AMRPN182
Pin : 021.279.1020
by Interconnectron GmbH

The Mating Connector

Plug : APRA06BFRDN170
Socket: 020.105.1020

Pin No.	Name
1	Phase U
2	Phase V
4	Phase W
5	Not used
6	Not used
⊕	Ground

Hall Sensor Output Signals

When the moving coil moves in the direction indicated by the arrow in the figure, the relationship between the hall sensor output signals S_u , S_v , S_w and the inverse power of each motor phase V_u , V_v , V_w becomes as shown in the figure below.

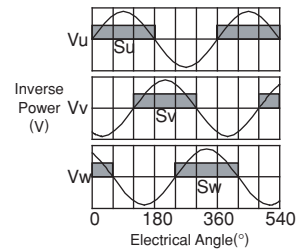

Moving Coil Model SGLFW-	L1	L2	L3	N	Approx. Mass kg
50□200B□D	215	120	180	6	3.5
50□380B□D	395	300	360	12	6.9

External Dimensions Units: mm

- Magnetic Way: SGLFM-50□□□A

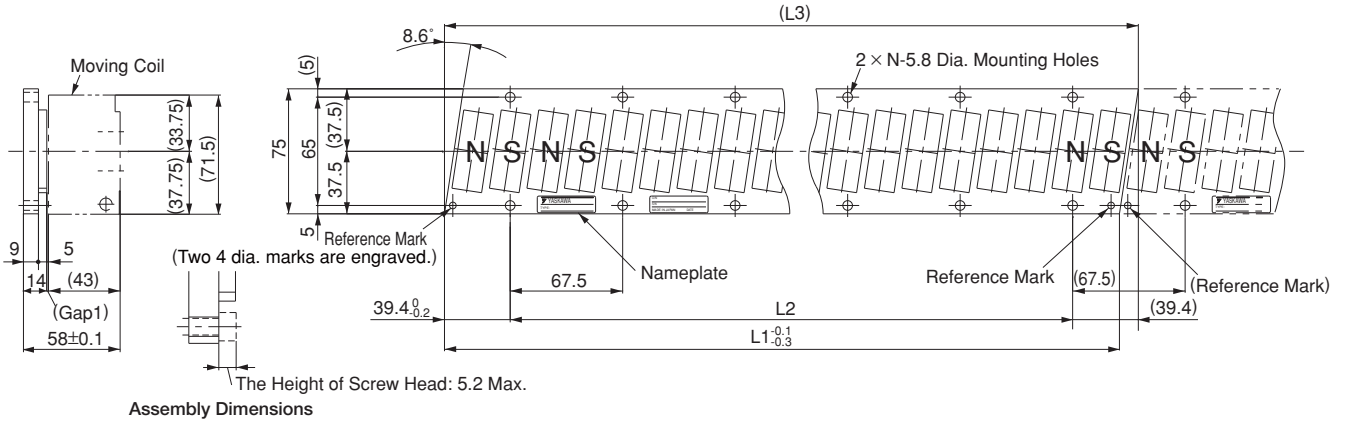

- Notes: 1 Multiple SGLFM-50□□□A magnetic ways can be connected. Connect magnetic ways so that the reference marks match one on the other in the same direction as shown in the figure.
 2 If you have a pacemaker or any other electronic medical device, do not go near the magnetic way of the linear servomotor.

Magnetic Way Model SGLFM-	$L1^{+0.1}_{-0.3}$	L2	(L3)	N	Approx. Mass kg
50405A	405	337.5 (67.5×5)	(416.3)	6	2.8
50675A	675	607.5 (67.5×9)	(686.3)	10	4.6
50945A	945	877.5 (67.5×13)	(956.3)	14	6.5

External Dimensions Units: mm

(4) SGLFW-1Z

- Moving Coil: SGLFW-1Z□□□□B□ (With a connector by Tyco Electronics AMP K.K.)

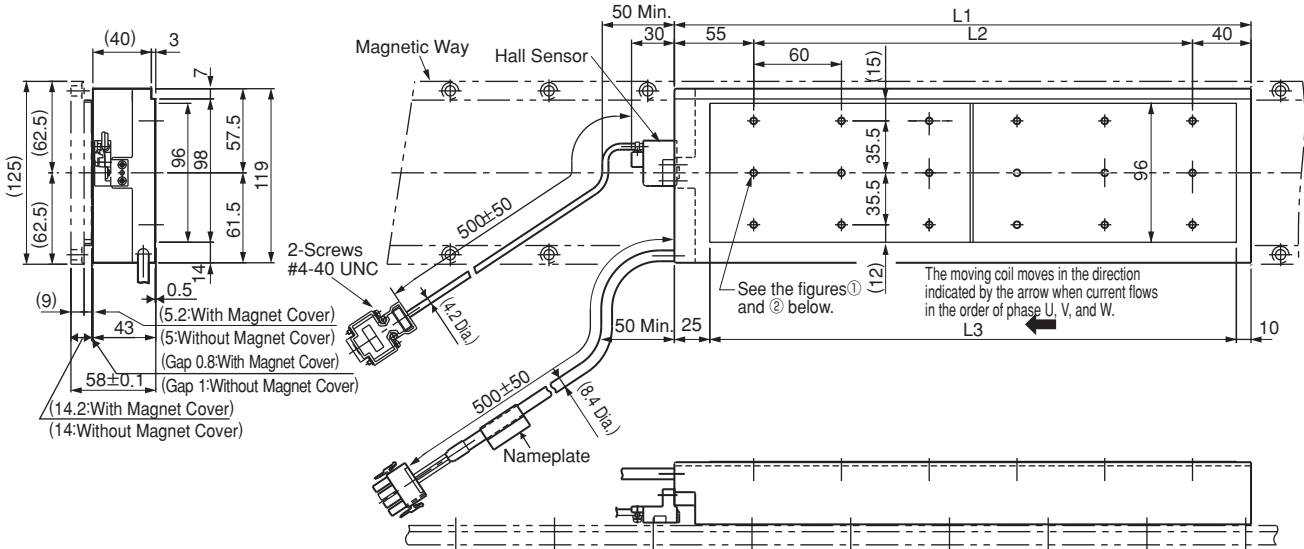

① SGLFW-1Z□200B□

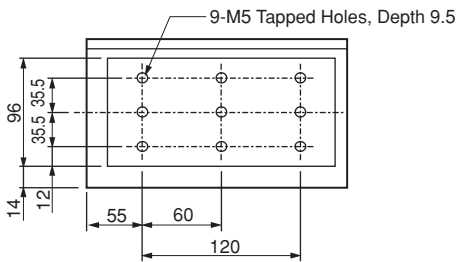

② SGLFW-1Z□380B□

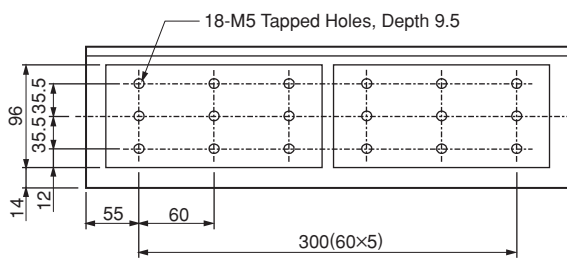

Hall Sensor Connector Specifications

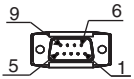

Pin Connector :
17JE-23090-02 (D8C)
by DDK Ltd.

The Mating Connector

Socket Connector:
17JE-13090-02 (D8C)
Stud: 17L-002C or
17L-002C1

Pin No.	Signal
1	+5V (Power supply)
2	Phase U
3	Phase V
4	Phase W
5	0V (Power supply)
6	Not used
7	Not used
8	Not used
9	Not used

Linear Servomotor Connector Specifications



Plug: 350779-1
Pin : 350218-3 or
350547-3 (No.1 to 3)
350654-1
350669-1 (No.4)
by Tyco Electronics AMP K.K.

The Mating Connector

Cap : 350780-1
Socket: 350536-3 or
350550-3

Pin No.	Signal	Wire Color
1	Phase U	Red
2	Phase V	White
3	Phase W	Black
4	FG	Green

Hall Sensor Output Signals

When the moving coil moves in the direction indicated by the arrow in the figure, the relationship between the hall sensor output signals S_u , S_v , S_w and the inverse power of each motor phase V_u , V_v , V_w becomes as shown in the figure below.

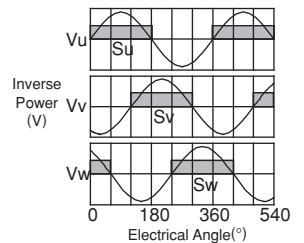

Moving Coil Model SGLFW-	L1	L2	L3	N	Approx. Mass kg
1Z□200B□	215	120	180	9	6.4
1Z□380B□	395	300	360	18	11.5

External Dimensions Units: mm

- Moving Coil: SGLFW-1Z□□□□B□D (With a connector by Interconnectron GmbH)

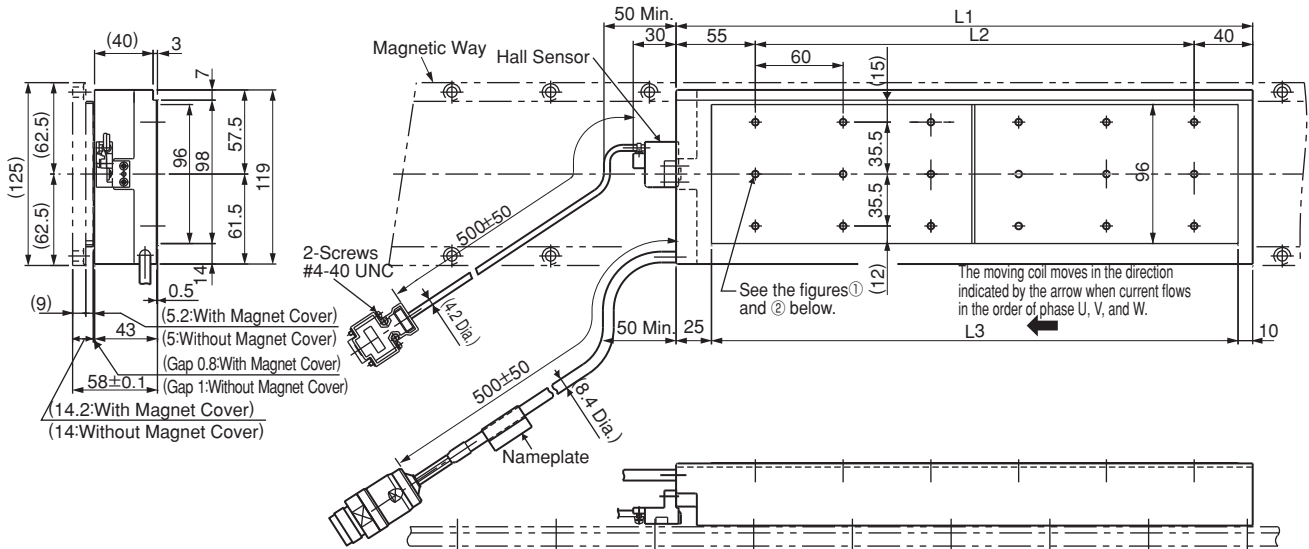

① SGLFW-1Z□□200B□D

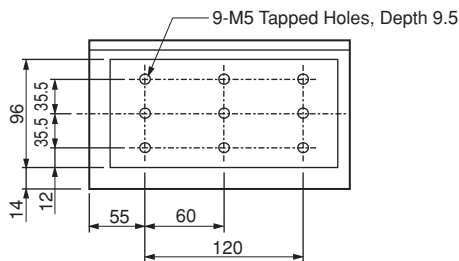

② SGLFW-1ZD380B□D

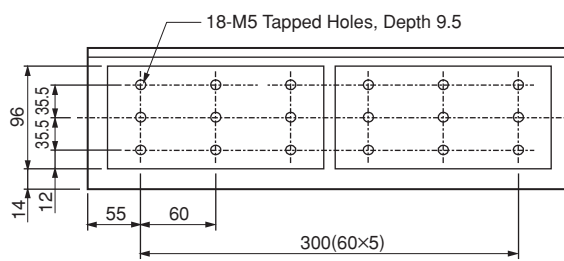

Hall Sensor Connector Specifications

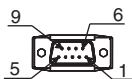

Pin Connector :
 17JE-23090-02 (D8C)
 by DDK Ltd.

The Mating Connector

Socket Connector:
 17JE-13090-02 (D8C)
 Stud: 17L-002C or
 17L-002C1

Pin No.	Signal
1	+5V (Power supply)
2	Phase U
3	Phase V
4	Phase W
5	0V (Power supply)
6	Not used
7	Not used
8	Not used
9	Not used

Linear Servomotor Connector Specifications

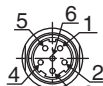

Extension: ARRA06AMRPN182
 Pin : 021.279.1020
 by Interconnectron GmbH

The Mating Connector

Plug : APRA06BFRDN170
 Socket: 020.105.1020

Pin No.	Name
1	Phase U
2	Phase V
4	Phase W
5	Not used
6	Not used
⊕	Ground

Hall Sensor Output Signals

When the moving coil moves in the direction indicated by the arrow in the figure, the relationship between the hall sensor output signals S_u , S_v , S_w and the inverse power of each motor phase V_u , V_v , V_w becomes as shown in the figure below.

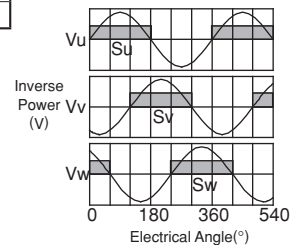

Moving Coil Model SGLFW-	L1	L2	L3	N	Approx. Mass kg
1Z□□200B□D	215	120	180	9	6.4
1ZD380B□D	395	300	360	18	11.5

External Dimensions Units: mm

• Magnetic Way: SGLFM-1Z□□□A

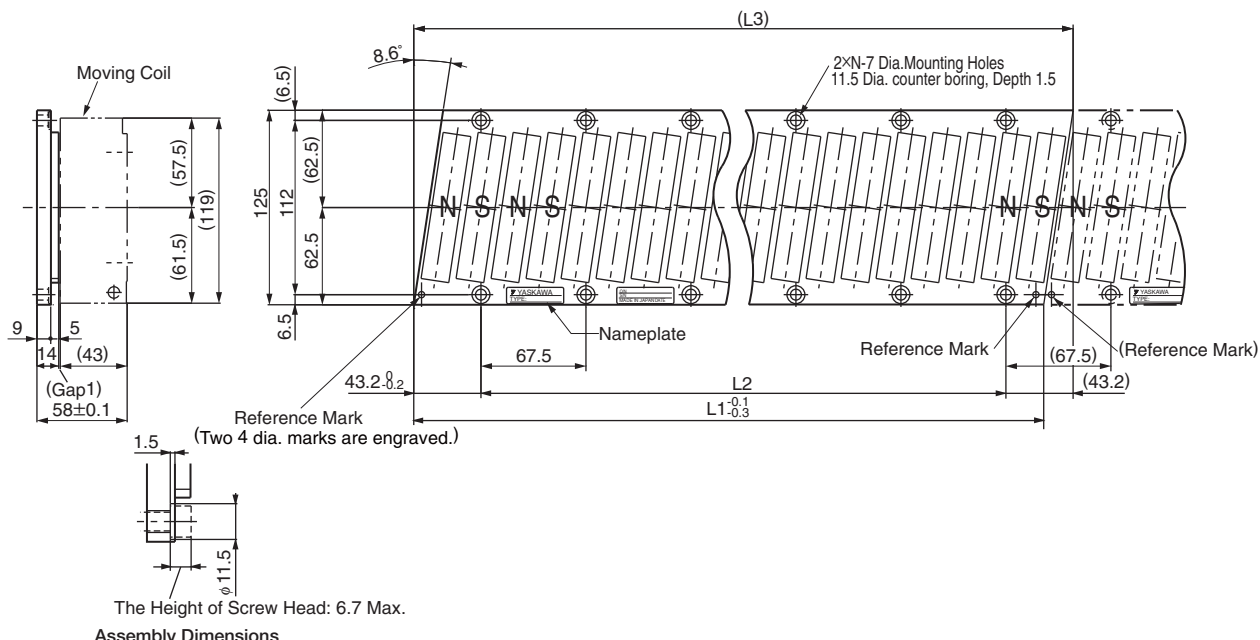

Assembly Dimensions

Notes: 1 Multiple SGLFM-1Z□□□A magnetic ways can be connected. Connect magnetic ways so that the reference marks match one on the other in the same direction as shown in the figure.

2 If you have a pacemaker or any other electronic medical device, do not go near the magnetic way of the linear servomotor.

Magnetic Way Model SGLFM-	L1 \pm 0.3	L2	L3	N	Approx. Mass kg
1Z405A	405	337.5 (67.5 × 5)	(423.9)	6	5
1Z675A	675	607.5 (67.5 × 9)	(693.9)	10	8.3
1Z945A	945	877.5 (67.5 × 13)	(963.9)	14	12

Selecting Cables

● Cables Connections

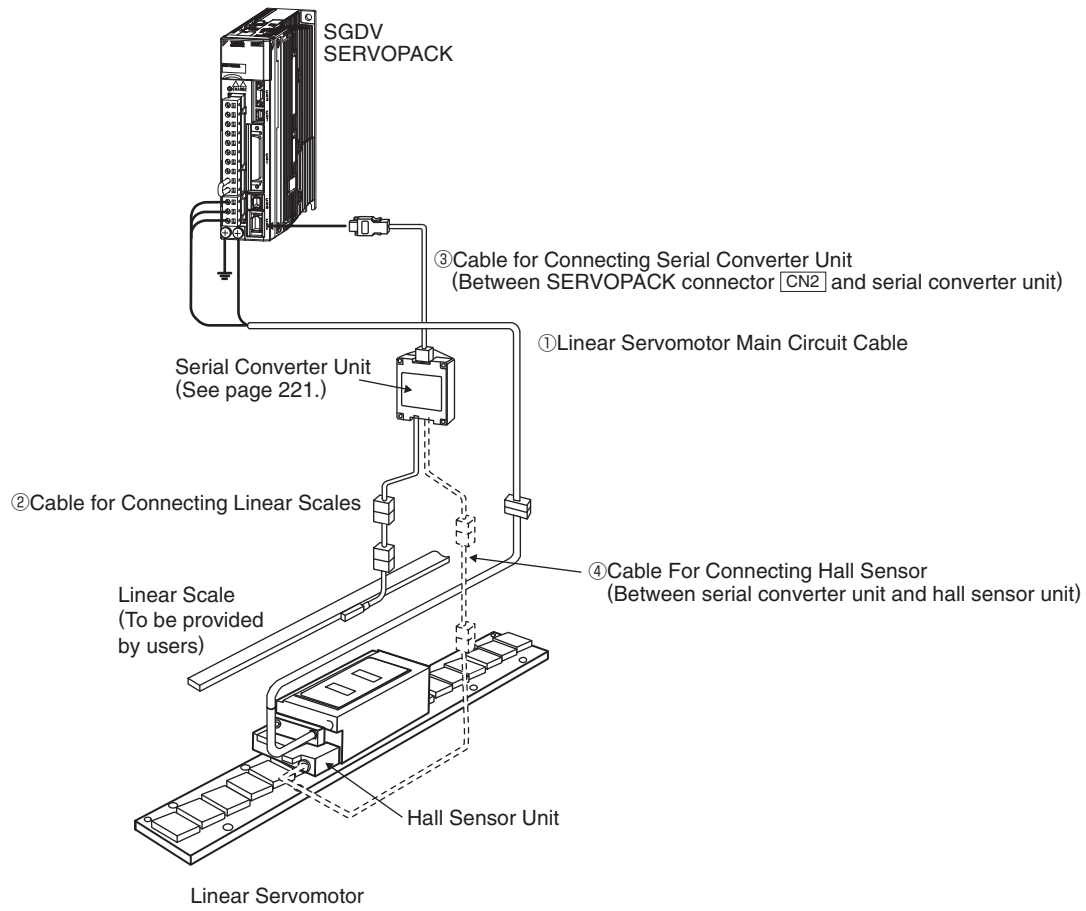

Selecting Cables

●Cables

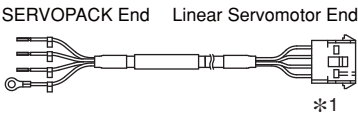
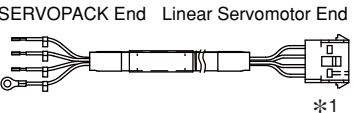
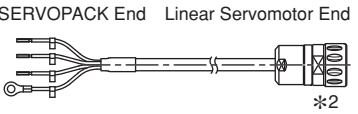
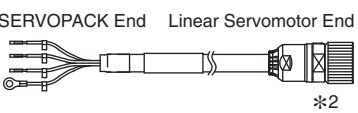
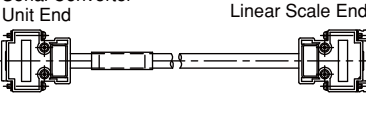
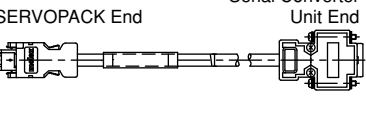
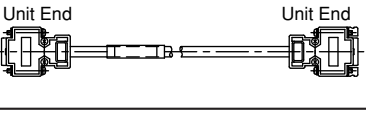
Name	Applicable Linear Servomotor Model	Length	Order No.	Specifications	Details
① Linear Servomotor Main Circuit Cables	SGLFW-20, -35	1 m	JZSP-CLN11-01-E		(1)
		3 m	JZSP-CLN11-03-E		
		5 m	JZSP-CLN11-05-E		
		10 m	JZSP-CLN11-10-E		
		15 m	JZSP-CLN11-15-E		
		20 m	JZSP-CLN11-20-E		
	SGLFW-50, -1Z	1 m	JZSP-CLN21-01-E		(2)
		3 m	JZSP-CLN21-03-E		
		5 m	JZSP-CLN21-05-E		
		10 m	JZSP-CLN21-10-E		
		15 m	JZSP-CLN21-15-E		
		20 m	JZSP-CLN21-20-E		
	SGLFW- □□A□□□□□D	1 m	JZSP-CLN14-01-E		(3)
		3 m	JZSP-CLN14-03-E		
		5 m	JZSP-CLN14-05-E		
		10 m	JZSP-CLN14-10-E		
		15 m	JZSP-CLN14-15-E		
		20 m	JZSP-CLN14-20-E		
	SGLFW- □□D□□□□□D	1 m	JZSP-CLN15-01-E		(4)
		3 m	JZSP-CLN15-03-E		
		5 m	JZSP-CLN15-05-E		
10 m		JZSP-CLN15-10-E			
15 m		JZSP-CLN15-15-E			
20 m		JZSP-CLN15-20-E			
② Cables for Connecting Linear Scales*3	All models	1 m	JZSP-CLL00-01-E		(5)
		3 m	JZSP-CLL00-03-E		
		5 m	JZSP-CLL00-05-E		
		10 m	JZSP-CLL00-10-E		
		15 m	JZSP-CLL00-15-E		
③ Cables for Connecting Serial Converter Units	All models	1 m	JZSP-CLP70-01-E		(6)
		3 m	JZSP-CLP70-03-E		
		5 m	JZSP-CLP70-05-E		
		10 m	JZSP-CLP70-10-E		
		15 m	JZSP-CLP70-15-E		
④ Cables for Connecting Hall Sensors	All models	1 m	JZSP-CLL10-01-E		(7)
		3 m	JZSP-CLL10-03-E		
		5 m	JZSP-CLL10-05-E		
		10 m	JZSP-CLL10-10-E		
		15 m	JZSP-CLL10-15-E		

*1: Connector by Tyco Electronics AMP K.K.

*2: Connector by Interconnectron GmbH

*3: When using serial converter unit JZDP-G00□-□□□-E, the maximum cable length should be 3 m.

Selecting Cables

(1) Linear Servomotor Main Circuit Cables: JZSP-CLN11-□□-E

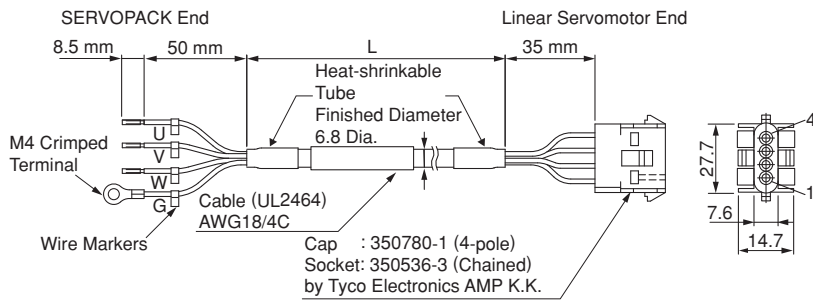

· Wiring Specifications

SERVOPACK-end Leads		Linear Servomotor-end Connector	
Wire Color	Signal	Signal	Pin No.
Red	Phase U	Phase U	1
White	Phase V	Phase V	2
Blue	Phase W	Phase W	3
Green/yellow	FG	FG	4

(2) Linear Servomotor Main Circuit Cables: JZSP-CLN21-□□-E

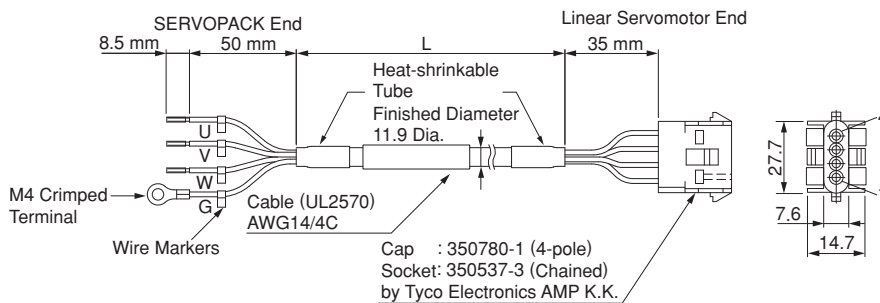

· Wiring Specifications

SERVOPACK-end Leads		Linear Servomotor-end Connector	
Wire Color	Signal	Signal	Pin No.
Red	Phase U	Phase U	1
White	Phase V	Phase V	2
Blue	Phase W	Phase W	3
Green/yellow	FG	FG	4

(3) Linear Servomotor Main Circuit Cables: JZSP-CLN14-□□-E

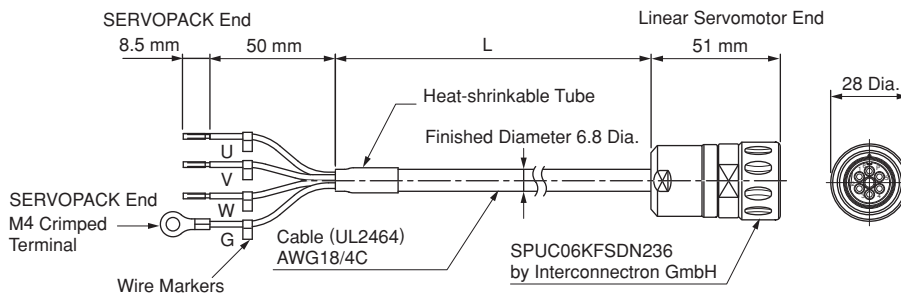

· Wiring Specifications

SERVOPACK-end Leads		Linear Servomotor-end Connector	
Wire Color	Signal	Signal	Pin No.
Black (White 1)	Phase U	Phase U	1
Black (White 2)	Phase V	Phase V	2
Black (White 3)	Phase W	Phase W	3
Green/yellow	FG	—	4
		—	5
		FG	6

Selecting Cables

(4) Linear Servomotor Main Circuit Cables: JZSP-CLN15-□□-E

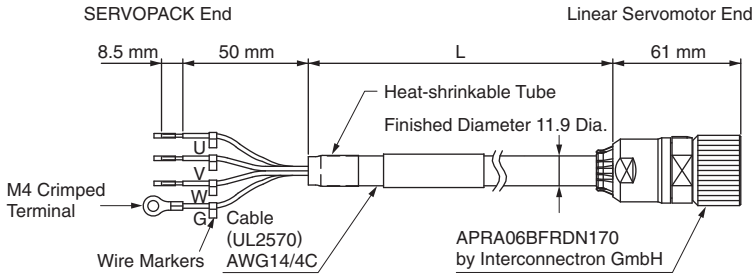

· Wiring Specifications

SERVOPACK-end Leads		Linear Servomotor-end Connector	
Wire Color	Signal	Signal	Pin No.
Red	Phase U	Phase U	1
White	Phase V	Phase V	2
Black	Phase W	FG	3
Green/yellow	FG	Phase W	4
		—	5
		—	6

(5) Cables for Connecting Linear Scales: JZSP-CLL00-□□-E

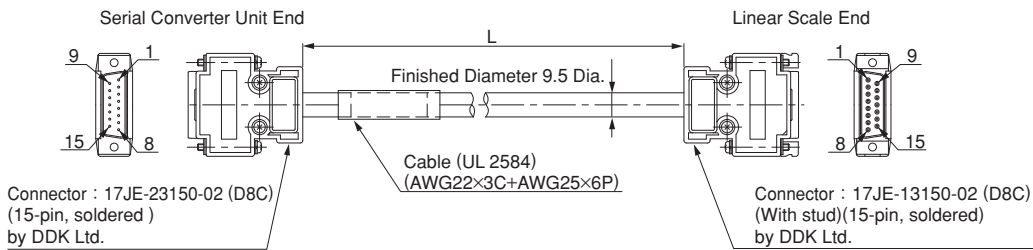

· Wiring Specifications

Serial Converter Unit End		Linear Scale End	
Pin No.	Signal	Pin No.	Signal
1	/Cos(V1-)	1	/Cos(V1-)
2	/Sin(V2-)	2	/Sin(V2-)
3	Ref(V0+)	3	Ref(V0+)
4	+5V	4	+5V
5	5Vs	5	5Vs
6	BID	6	BID
7	Vx	7	Vx
8	Vq	8	Vq
9	Cos(V1+)	9	Cos(V1+)
10	Sin(V2+)	10	Sin(V2+)
11	/Ref(V0+)	11	/Ref(V0-)
12	0V	12	0V
13	0Vs	13	0Vs
14	DIR	14	DIR
15	Inner	15	Inner
Case	Shield	Case	Shield

Selecting Cables

(6) Cables for Connecting Serial Converter Units: JZSP-CLP70-□□-E

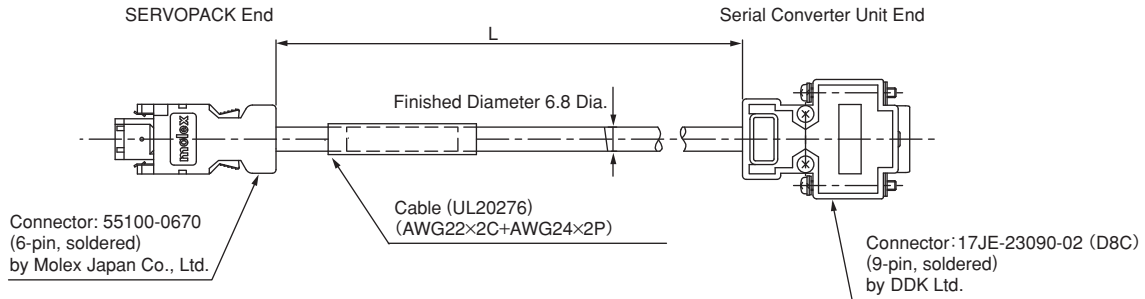

• Wiring Specifications

SERVOPACK End			Serial Converter Unit End		
Pin No.	Signal	Wire Color	Pin No.	Signal	Wire Color
1	PG5V	Red	1	+5V	Red
2	PG0V	Black	5	0V	Black
3	-	-	3	-	-
4	-	-	4	-	-
5	PS	Light blue	2	Phase S output	Light blue
6	/PS	Light blue/white	6	Phase /S output	Light blue/white
Shell	Shield	-	Case	Shield	-
			7	-	-
			8	-	-
			9	-	-

(7) Cables for Connecting Hall Sensors: JZSP-CLL10-□□-E

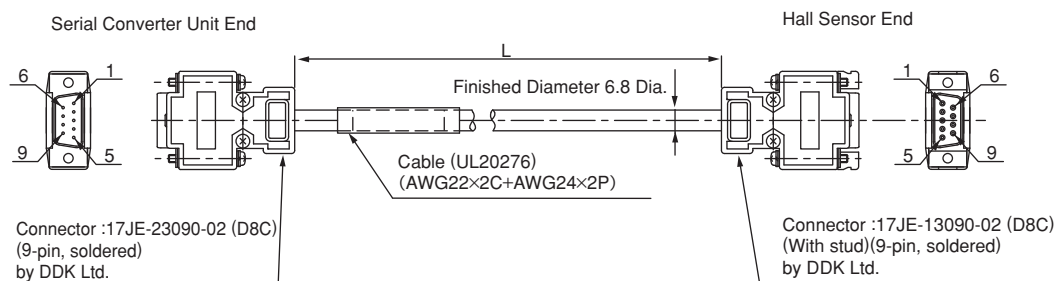

• Wiring Specifications

Serial Converter Unit End		Hall Sensor End	
Pin No.	Signal	Pin No.	Signal
1	+5V	1	+5V
2	Phase U input	2	Phase U input
3	Phase V input	3	Phase V input
4	Phase W input	4	Phase W input
5	0V	5	0V
6	-	6	-
7	-	7	-
8	-	8	-
9	-	9	-
Case	Shield	Case	Shield

Linear Servomotors

SGLTW

(With T-type iron core)

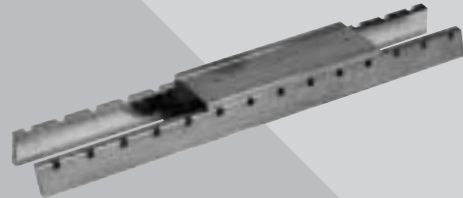

Model Designations

● Moving Coil

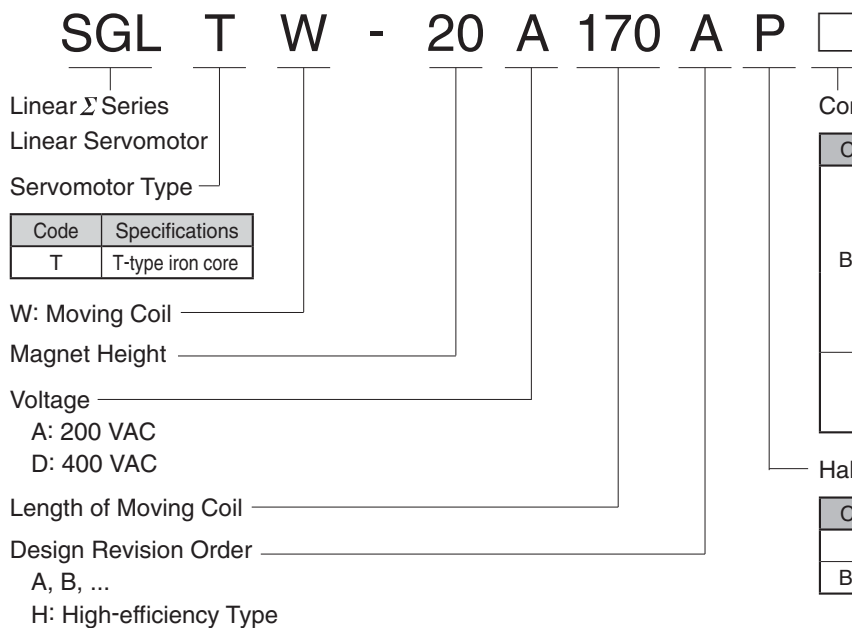

Connector for Main Circuit Cable

Code	Specification	Applicable Model
Blank	Connector by Tyco Electronics AMP K.K.	SGLTW -20A□□□□□□
		-35A□□□□□□
		-50A□□□□□□
D	MS connector	SGLTW -40□□□□□B□
		-80□□□□□B□
		Connector by Interconnectron GmbH
D	Connector by Interconnectron GmbH	SGLTW -35D□□□□H□
		-50D□□□□H□

Hall Sensor

Code	Specifications
P	With hall sensor
Blank	Without hall sensor

● Magnetic Way

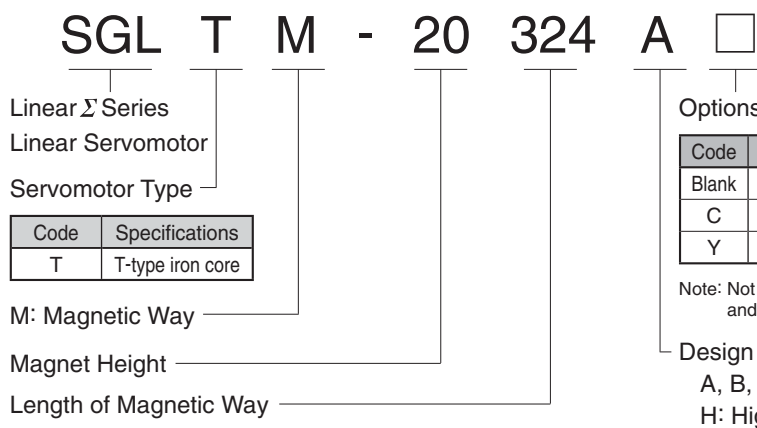

Options

Code	Specifications	Applicable Model
Blank	Standard	All models
C	With magnet cover	Models with core
Y	With base and magnet cover	SGLTM-20, -35, -40, -80 ^(Note)

Note: Not available for these models: the SGLTM-35□□□□H and the SGLTM-50□□□□H.

Features

- Direct-feed mechanism for high-speed and high-precision positioning.
- Yaskawa's unique construction principles of the TW linear motors negate the effects of the magnetic attraction force between the relative motor members.
- Lack of magnetic attraction helps to extend the life of the linear motion guides and to minimize operation noise.
- Very little cogging.

Application Examples

- Feeders and loaders
- Mounters
- Machine tools

● Precautions on Moving Coil with Hall Sensor

When using a moving coil with a hall sensor, the magnetic way must completely cover the bottom of the hall sensor. Refer to the example showing the correct installation.

When determining the length of the moving coil's stroke or the length of the magnetic way, consider the total length of the moving coil and the hall sensor unit. Refer to the following table.

< Correct >

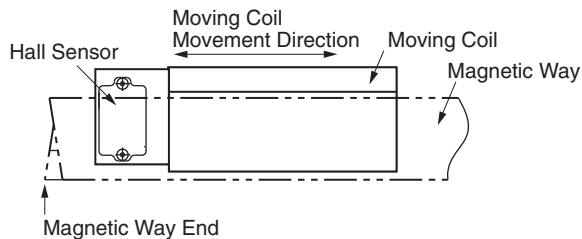

< Incorrect >

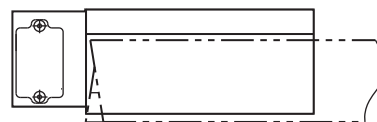

The total length of moving coil with hall sensor

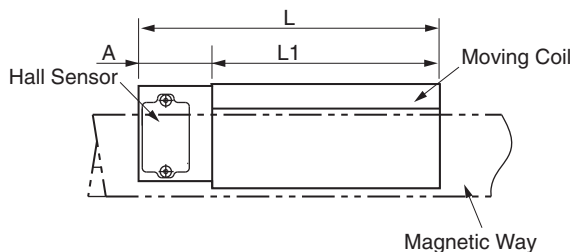

Moving Coil Model	Length of Moving Coil L1 (mm)	Length of Hall Sensor Unit A (mm)	Total Length L (mm)
20A170AP□	170	34	204
20A320AP□	315		349
20A460AP□	460		494
35A170AP□	170	34	204
35A320AP□	315		349
35A460AP□	460		494
35□170HP□	170	34	204
35□320HP□	315		349
50□170HP□	170		204
50□320HP□	315	349	
40A400AP□	395	26	421
40A600AP□	585	36	621
80A400AP□	395	26	421
80A600AP□	585	36	621
40□400BP□	395	26	421
40□600BP□	575		601
80□400BP□	395		421
80□600BP□	575		601

Ratings and Specifications

Time Rating: Continuous

Insulation Resistance: 500 VDC, 10 MΩ min.

Ambient Temperature: 0 to 40°C

Excitation: Permanent magnet

Withstand Voltage: 1500 VAC for one minute

Enclosure: Self-cooled

Ambient Humidity: 20% to 80% (no condensation)

Allowable Winding Temperature: 130°C (Thermal class B)

200-V Class

Linear Servomotor Model SGLTW- <input type="text"/>		Standard Type										High-efficiency Type			
		20A			35A			40A		80A		35A		50A	
		170A	320A	460A	170A	320A	460A	400B	600B	400B	600B	170H	320H	170H	320H
Peak Speed	m/s	5	5	5	5	5	5	3.1	3.1	2.5	2.5	4.8	4.8	3.2	3.1
Rated Force*	N	130	250	380	220	440	670	670	1000	1300	2000	300	600	450	900
Rated Current*	Arms	2.3	4.4	6.7	3.5	7	10.7	7.3	10.9	11.1	17.1	5.1	10.1	4.9	9.8
Peak Force*	N	380	760	1140	660	1320	2000	2600	4000	5000	7500	600	1200	900	1800
Peak Current*	Arms	7.7	15.4	23.2	12.1	24.2	36.7	39.4	60.6	57.9	86.9	11.9	23.9	11.5	22.9
Moving Coil Mass	kg	2.5	4.6	6.7	3.7	6.8	10	15	23	24	35	4.9	8.8	6	11
Force Constant	N/Arms	61	61	61	67.5	67.5	67.5	99.1	99.1	126	126	64	64	98.5	98.5
BEMF Constant	V/(m/s)	20.3	20.3	20.3	22.5	22.5	22.5	33	33	42	42	21.3	21.3	32.8	32.8
Motor Constant	N/√w	18.7	26.5	32.3	26.7	37.5	46.4	61.4	75.2	94.7	116	37.4	52.9	50.3	71.1
Electrical Time Constant	ms	5.9	5.9	5.9	6.9	6.8	7	15.2	15.2	17	17	15.1	15.1	16.5	16.5
Mechanical Time Constant	ms	7.5	6.5	6.4	5.2	4.8	4.6	4	4	3	3	3.3	3.3	2.8	2.8
Thermal Resistance (With Heat Sink)	K/W	1.01	0.49	0.38	0.76	0.44	0.32	0.24	0.2	0.22	0.18	0.76	0.4	0.61	0.3
Thermal Resistance (Without Heat Sink)	K/W	1.82	1.11	0.74	1.26	0.95	0.61	0.57	0.4	0.47	0.33	1.26	0.83	0.97	0.8
Magnetic Attraction*1	N	0	0	0	0	0	0	0	0	0	0	0	0	0	0
Magnetic Attraction(on one side)*2	N	800	1590	2380	1400	2780	4170	3950	5890	7650	11400	1400	2780	2000	3980
Applicable SERVOPACK	SGDV-	3R8A	7R6A	120A	5R5A	120A	180A	180A	330A	330A	550A	5R5A	120A	5R5A	120A

*1 : The unbalanced magnetic gap resulted from the moving coil installation condition causes a magnetic attraction on the moving coil.

*2 : The value indicates the magnetic attraction generated on one side of the magnetic way.

Notes: 1 The items marked with an * and *Force and Speed Characteristics* (on the next page) are the values at a motor winding temperature of 100°C during operation in combination with a SERVOPACK. The others are at 20°C.

2 The above specifications show the values under the cooling condition when a heat sink (aluminum board) listed in the following table is mounted on the moving coil.

Heat Sink Size	254 mm×254 mm×25 mm : SGLTW-20A170A,-35A170A
	400 mm×500 mm×40 mm : SGLTW-20A320A,-20A460A,-35A170H,-35A320A,-35A320H,-35A460A,-50A170H
	609 mm×762 mm×50 mm : SGLTW-40A400B,-40A600B,-50A320H,-80A400B,-80A600B

400-V Class

Linear Servomotor Model SGLTW- <input type="text"/>		Standard Type				High-efficiency Type			
		40D		80D		35D		50D	
		400B	600B	400B	600B	170H	320H	170H	320H
Peak Speed	m/s	3.1	3.1	3.1	3.1	5	5	4	4
Rated Force*	N	670	1000	1300	2000	300	600	450	900
Rated Current*	Arms	3.7	5.5	7.2	11.1	3.2	6.5	3.2	6.3
Peak Force*	N	2600	4000	5000	7500	600	1200	900	1800
Peak Current*	Arms	20.7	30.6	37.6	56.4	7.7	15.5	7.4	14.8
Moving Coil Mass	kg	15	23	24	35	4.7	8.8	6	11
Force Constant	N/Arms	196.1	196.1	194.4	194.4	99.6	99.6	153.3	153.3
BEMF Constant	V/(m/s)	65.4	65.4	64.8	64.8	33.2	33.2	51.1	51.1
Motor Constant	N/√w	59.6	73	85.9	105.2	36.3	51.4	48.9	69.1
Electrical Time Constant	ms	14.3	14.4	15.6	15.6	14.3	14.4	15.6	15.6
Mechanical Time Constant	ms	4.3	4.2	3.2	3.2	3.5	3.3	2.5	2.5
Thermal Resistance (With Heat Sink)	K/W	0.24	0.2	0.22	0.18	0.76	0.4	0.61	0.3
Thermal Resistance (Without Heat Sink)	K/W	0.57	0.4	0.47	0.33	1.26	0.83	0.97	0.8
Magnetic Attraction*1	N	0	0	0	0	0	0	0	0
Magnetic Attraction(on one side)*2	N	3950	5890	7650	11400	1400	2780	2000	3980
Applicable SERVOPACK	SGDV-	120D	170D	170D	260D	3R5D	8R4D	3R5D	8R4D

*1 : The unbalanced magnetic gap resulted from the moving coil installation condition causes a magnetic attraction on the moving coil.

*2 : The value indicates the magnetic attraction generated on one side of the magnetic way.

Notes: 1 The items marked with an * and *Force and Speed Characteristics* (on page 183) are the values at a motor winding temperature of 100°C during operation in combination with a SERVOPACK. The others are at 20°C.

2 The above specifications show the values under the cooling condition when a heat sink (aluminum board) listed in the following table is mounted on the moving coil.

Heat Sink Size	400 mm×500 mm×40 mm : SGLTW-35D170H,-35D320H,-50D170H
	609 mm×762 mm×50 mm : SGLTW-40D400B,-40D600B,-50D320H,-80D400B,-80D600B

Ratings and Specifications

- **Force and Speed Characteristics** **A** : Continuous Duty Zone **B** : Intermittent Duty Zone

200-V Class Standard Type

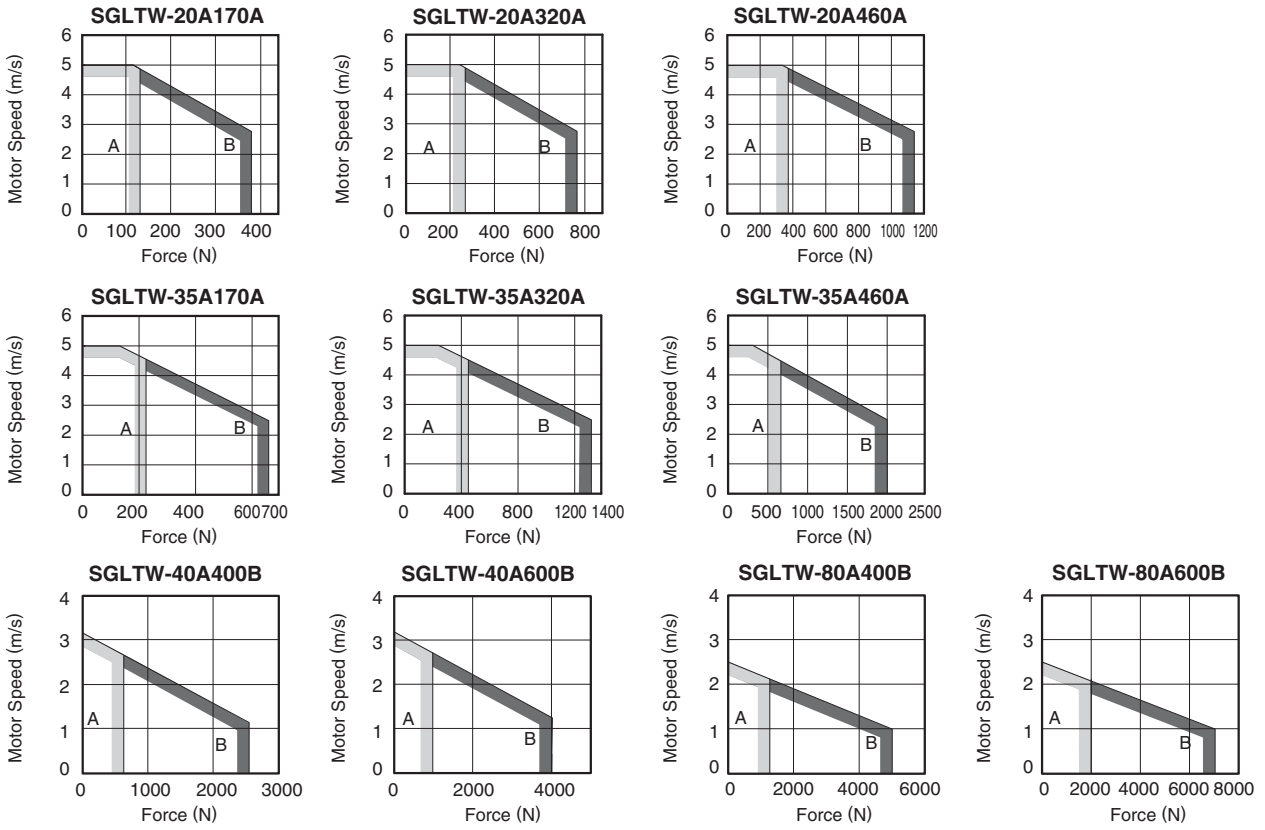

200-V Class High-efficiency Type

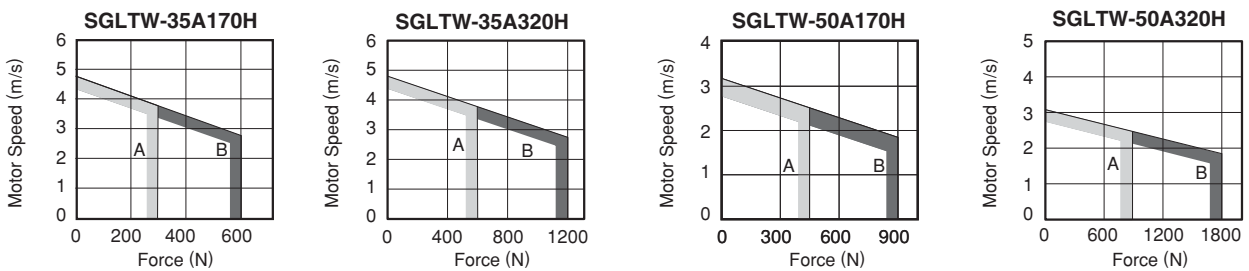

Note: When the effective force during intermittent duty is within the rated force, the servomotor can be used within the intermittent duty zone.

Ratings and Specifications

● Force and Speed Characteristics (cont'd)

□ A : Continuous Duty Zone □ B : Intermittent Duty Zone

400-V Class Standard Type

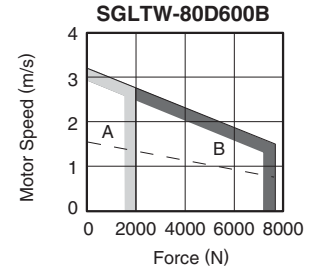
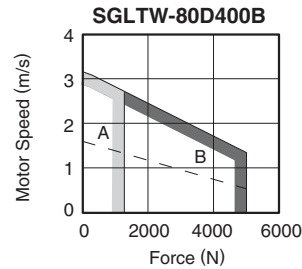
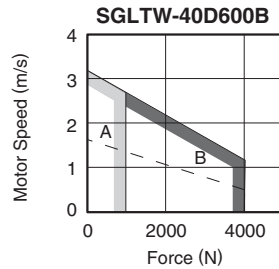
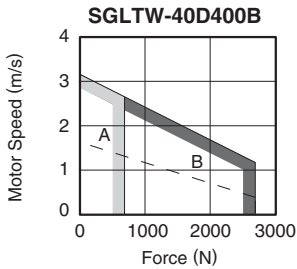

400-V Class High-efficiency Type

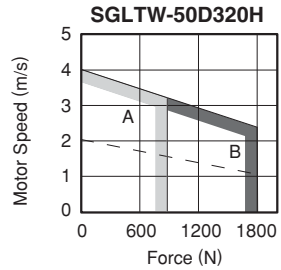
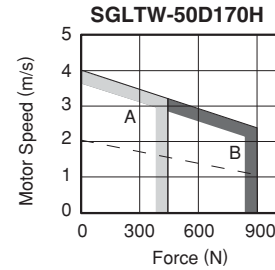
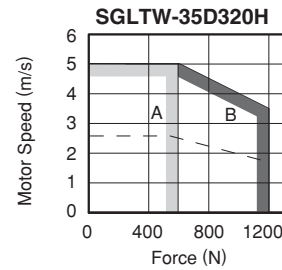
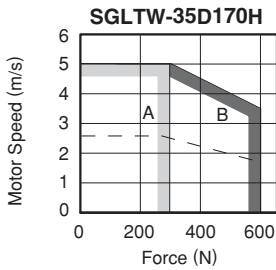

Notes: 1 When the effective force during intermittent duty is within the rated force, the servomotor can be used within the intermittent duty zone.
2 The dotted line indicates the characteristics when a 400-VAC linear servomotor is used with 200-V input power supply. In this case, a serial converter unit is required. Contact your Yaskawa representative for details.

● Mechanical Specifications

(1) Impact Resistance

- Impact acceleration: 196 m/s²
- Impact occurrences: twice

(2) Vibration Resistance

The linear servomotors will withstand the following vibration acceleration in three directions: Vertical, side to side, and front to back.

- Vibration acceleration: 49 m/s²

External Dimensions Units: mm

(1) Standard Type SGLTW-20

- Moving Coil: SGLTW-20A□□□A□ (With a connector by Tyco Electronics AMP K.K.)

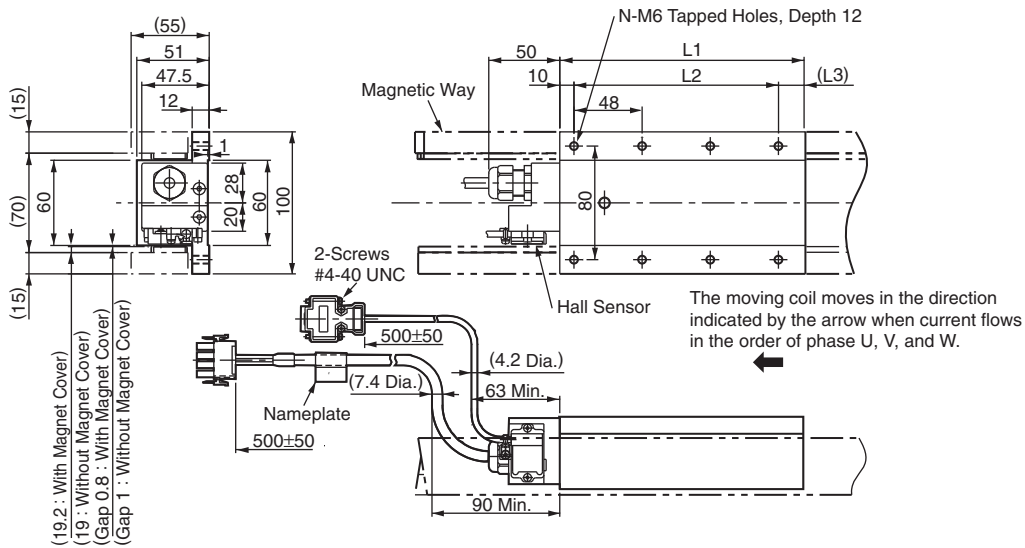

Hall Sensor Connector Specifications

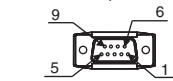

Pin Connector:
 17JE-23090-02 (D8C)
 by DDK Ltd.

The Mating Connector

Socket Connector:
 17JE-13090-02 (D8C)
 Stud: 17L-002C or
 17L-002C1

Pin No.	Signal
1	+5VDC
2	Phase U
3	Phase V
4	Phase W
5	0V
6	Not used
7	Not used
8	Not used
9	Not used

Linear Servomotor Connector Specifications

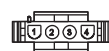

Plug: 350779-1
 Pin : 350218-3 or
 350547-3 (No.1 to 3)
 350654-1
 350669-1 (No.4)
 by Tyco Electronics AMP K.K.

The Mating Connector

Cap : 350780-1
 Socket: 350536-3 or
 350550-3

Pin No.	Signal	Wire Color
1	Phase U	Red
2	Phase V	White
3	Phase W	Black
4	Ground	Green

Hall Sensor Output Signals

When the moving coil moves in the direction indicated by the arrow in the figure, the relationship between the hall sensor output signals S_u , S_v , S_w and the inverse power of each motor phase V_u , V_v , V_w becomes as shown in the figure below.

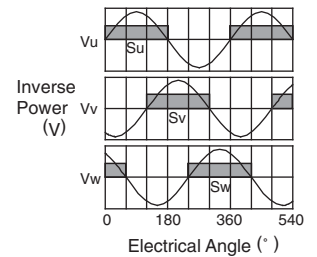

Moving Coil Model SGLTW-	L1	L2	(L3)	N	Approx. Mass kg
20A170A□	170	144 (48×3)	(16)	8	2.5
20A320A□	315	288 (48×6)	(17)	14	4.6
20A460A□	460	432 (48×9)	(18)	20	6.7

External Dimensions Units: mm

- Magnetic Way : SGLTM-20□□□A□

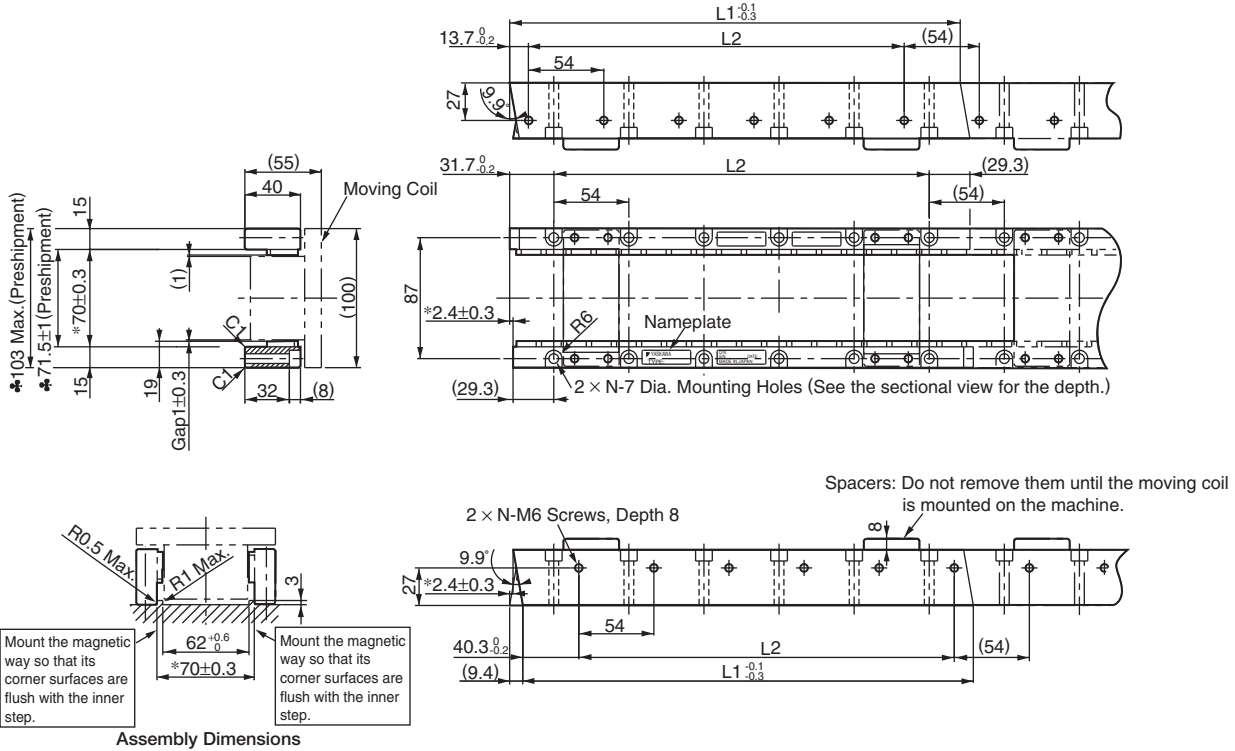

- Notes: 1 Two magnetic ways for both ends of moving coil make one set. Spacers are mounted on magnetic ways for safety during transportation. Do not remove the spacers until the moving coil is mounted on a machine.
 2 If you have a pacemaker or any other electronic medical device, do not go near the magnetic way of the linear servomotor.
 3 Two magnetic ways in a set can be connected to each other.
 4 The dimensions marked with an * are the dimensions between the magnetic ways. Be sure to follow exactly the dimensions specified in the figure above. Mount magnetic ways as shown in Assembly Dimensions. The values with a ♣ are the dimensions at preshipment.
 5 Use socket headed screws of strength class 10.9 minimum for magnetic way mounting screws. Do not use stainless steel screws.

Magnetic Way Model SGLTM-	L1 [♣] _{0.3} ^{0.1}	L2	N	Approx. Mass kg
20324A□	324	270 (54×5)	6	3.4
20540A□	540	486 (54×9)	10	5.7
20756A□	756	702 (54×13)	14	7.9

External Dimensions Units: mm

- Magnetic Way with Base: SGLTM-20□□□AY

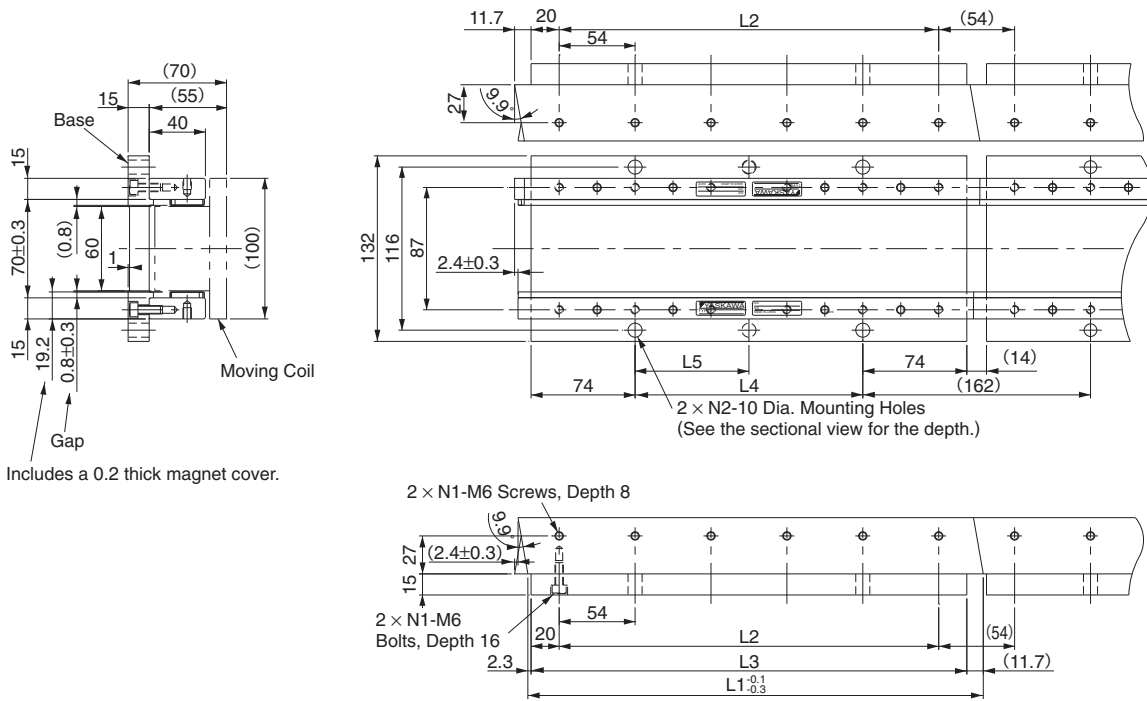

Includes a 0.2 thick magnet cover.

- Notes: 1 If you have a pacemaker or any other electronic medical device, do not go near the magnetic way of the linear servomotor.
 2 Two magnetic ways in a set can be connected to each other.
 3 The characteristics of the magnetic way with base are the same as of the magnetic way without base (SGLTM-20□□□A).

Magnetic Way Model SGLTM-	L1	L2	L3	L4	L5	N1	N2	Approx. Mass kg
20324AY	324	270	310	162	162	6	2	5.1
20540AY	540	486	526	378	189	10	3	8.5
20756AY	756	702	742	594	198	14	4	12

External Dimensions Units: mm

(2) Standard Type SGLTW-35

- Moving Coil: SGLTW-35A□□□A□ (With a connector by Tyco Electronics AMP K.K.)

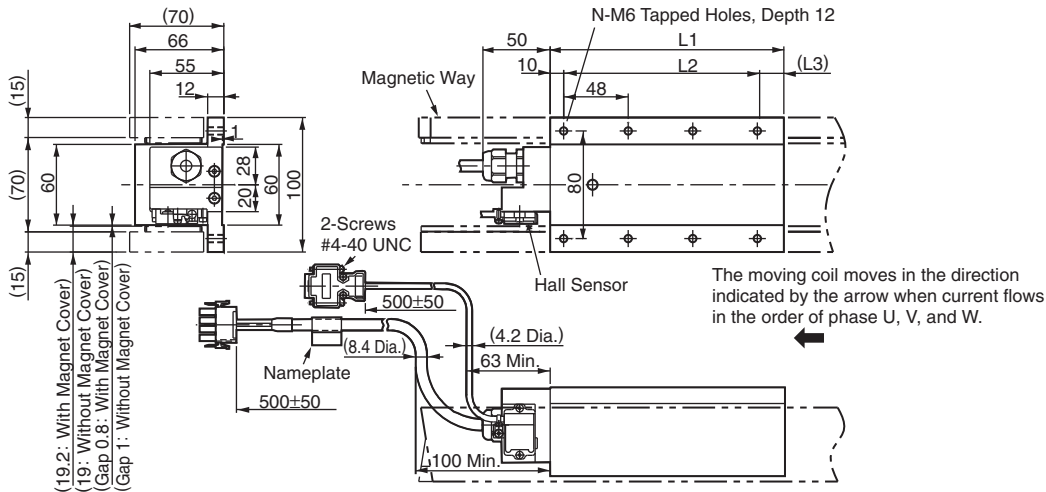

Hall Sensor Connector Specifications

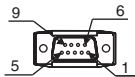

Pin Connector:
17JE-23090-02 (D8C)
by DDK Ltd.

The Mating Connector

Socket Connector:
17JE-13090-02 (D8C)
Stud: 17L-002C or
17L-002C1

Pin No.	Signal
1	+5VDC
2	Phase U
3	Phase V
4	Phase W
5	0V
6	Not used
7	Not used
8	Not used
9	Not used

Linear Servomotor Connector Specifications



Plug: 350779-1
Pin : 350218-3 or
350547-3 (No.1 to 3)
350654-1
350669-1 (No.4)
by Tyco Electronics AMP K.K.

The Mating Connector

Cap : 350780-1
Socket: 350536-3 or
350550-3

Pin No.	Signal	Wire Color
1	Phase U	Red
2	Phase V	White
3	Phase W	Black
4	Ground	Green

Hall Sensor Output Signals

When the moving coil moves in the direction indicated by the arrow in the figure, the relationship between the hall sensor output signals S_u , S_v , S_w and the inverse power of each motor phase V_u , V_v , V_w becomes as shown in the figure below.

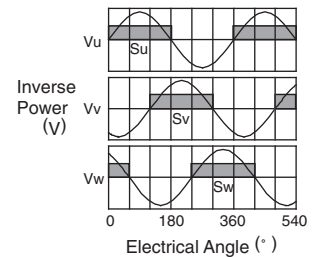

Moving Coil Model SGLTW-	L1	L2	(L3)	N	Approx. Mass kg
35A170A□	170	144 (48×3)	(16)	8	3.7
35A320A□	315	288 (48×6)	(17)	14	6.8
35A460A□	460	432 (48×9)	(18)	20	10

External Dimensions Units: mm

- Magnetic Way: SGLTM-35□□□A□

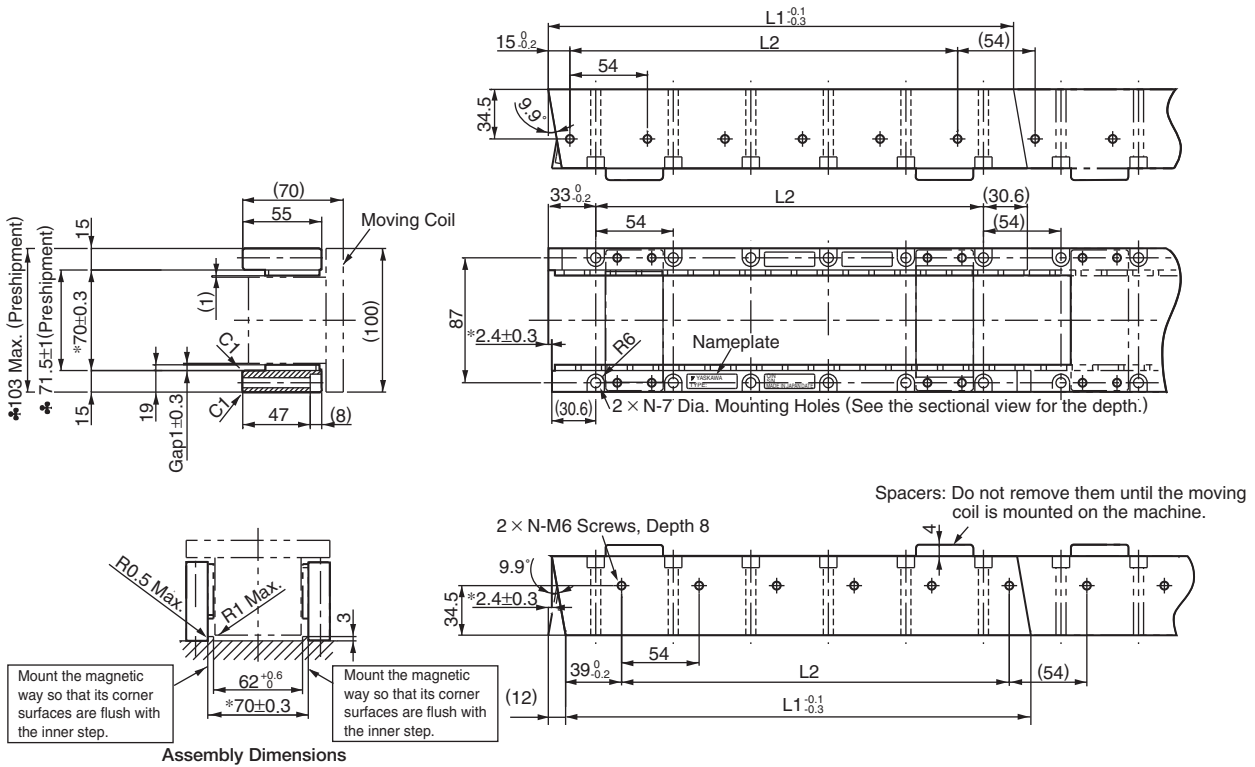

- Notes: 1 Two magnetic ways for both ends of moving coil make one set. Spacers are mounted on magnetic ways for safety during transportation. Do not remove the spacers until the moving coil is mounted on a machine.
 2 If you have a pacemaker or any other electronic medical device, do not go near the magnetic way of the linear servomotor.
 3 Two magnetic ways in a set can be connected to each other.
 4 The dimensions marked with an * are the dimensions between the magnetic ways. Be sure to follow exactly the dimensions specified in the figure above. Mount magnetic ways as shown in Assembly Dimensions. The values with a ♣ are the dimensions at preshipment.
 5 Use socket headed screws of strength class 10.9 minimum for magnetic way mounting screws. Do not use stainless steel screws.

Magnetic Way Model SGLTM-	L1 ^{0.1} _{0.3}	L2	N	Approx. Mass kg
35324A□	324	270 (54×5)	6	4.8
35540A□	540	486 (54×9)	10	8
35756A□	756	702 (54×13)	14	11

External Dimensions Units: mm

• Magnetic Way with Base: SGLTM-35□□□AY

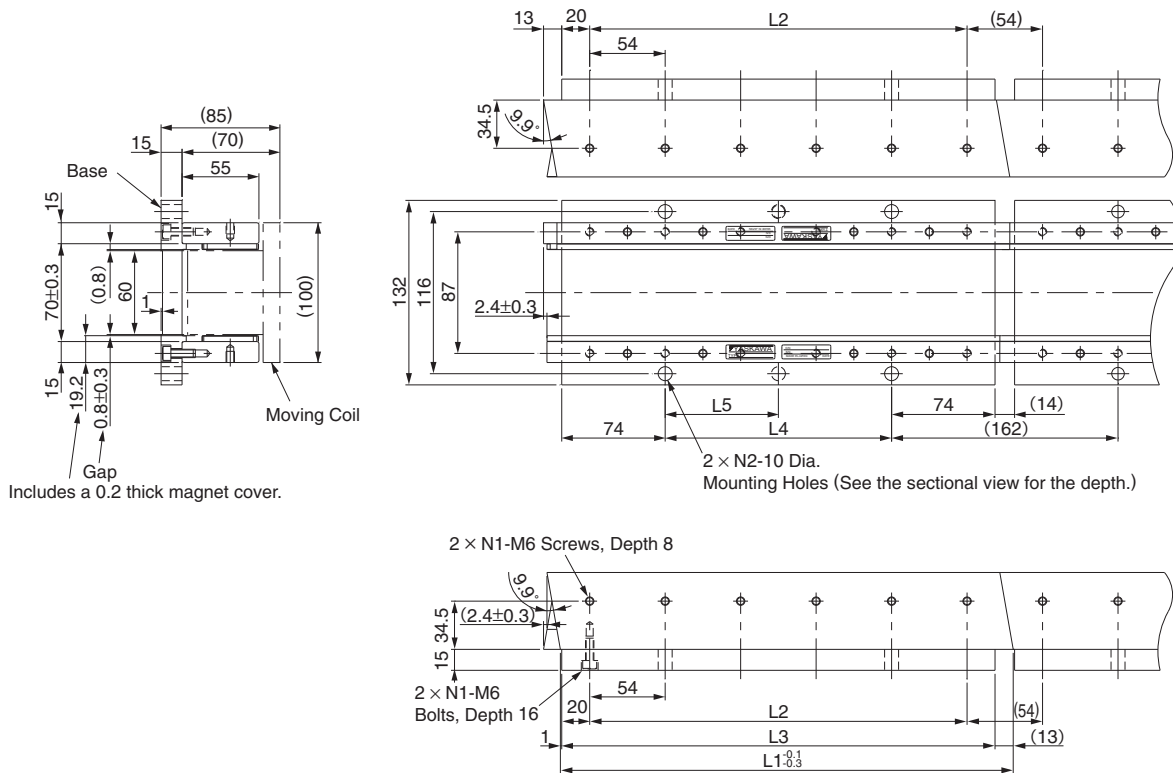

- Notes: 1 If you have a pacemaker or any other electronic medical device, do not go near the magnetic way of the linear servomotor.
 2 Two magnetic ways in a set can be connected to each other.
 3 The characteristics of the magnetic way with base are the same as of the magnetic way without base (SGLTM-35□□□A).

Magnetic Way Model SGLTM-	L1	L2	L3	L4	L5	N1	N2	Approx. Mass kg
35324AY	324	270	310	162	162	6	2	6.4
35540AY	540	486	526	378	189	10	3	11
35756AY	756	702	742	594	198	14	4	15

External Dimensions Units: mm

(3) Standard Type SGLTW-40

- Moving Coil: SGLTW-40□□□□□B□ (With an MS connector)

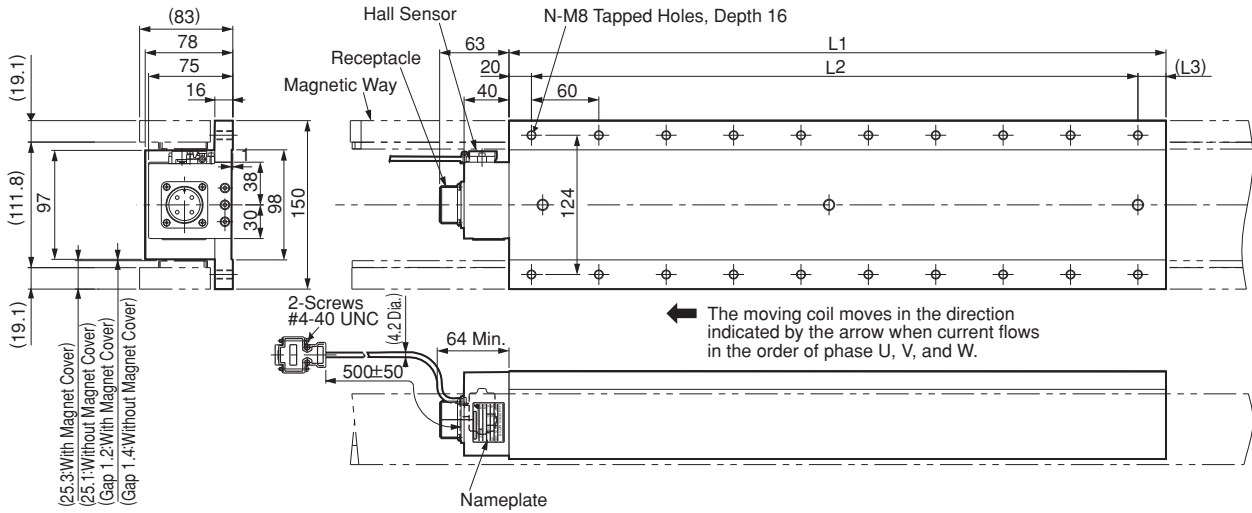

Hall Sensor Connector Specifications

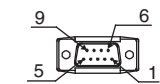

Pin Connector:
 17JE-23090-02 (D8C)
 by DDK Ltd.

The Mating Connector

Socket Connector:
 17JE-13090-02 (D8C)
 Stud: 17L-002C or
 17L-002C1

Pin No.	Signal
1	+5VDC
2	Phase U
3	Phase V
4	Phase W
5	0V
6	Not used
7	Not used
8	Not used
9	Not used

Linear Servomotor Connector Specifications



Receptacle type: MS3102A-22-22P
 by DDK Ltd.

The Mating Connector

L-shaped plug type : MS3108B22-22S
 Straight plug type : MS3106B22-22S
 Cable clamp type : MS3057-12A

Pin No.	Signal
A	Phase U
B	Phase V
C	Phase W
D	Ground

Hall Sensor Output Signals

When the moving coil moves in the direction indicated by the arrow in the figure, the relationship between the hall sensor output signals S_u , S_v , S_w and the inverse power of each motor phase V_u , V_v , V_w becomes as shown in the figure below.

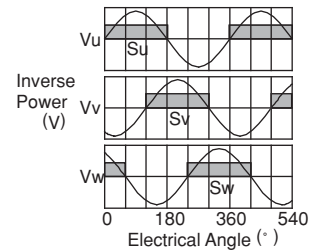

Moving Coil Model SGLTW-	L1	L2	(L3)	N	Approx. Mass kg
40□400B□	395	360(60×6)	(15)	14	15
40□600B□	575	540(60×9)	(15)	20	22

External Dimensions Units: mm

• Magnetic Way : SGLTM-40□□□A□

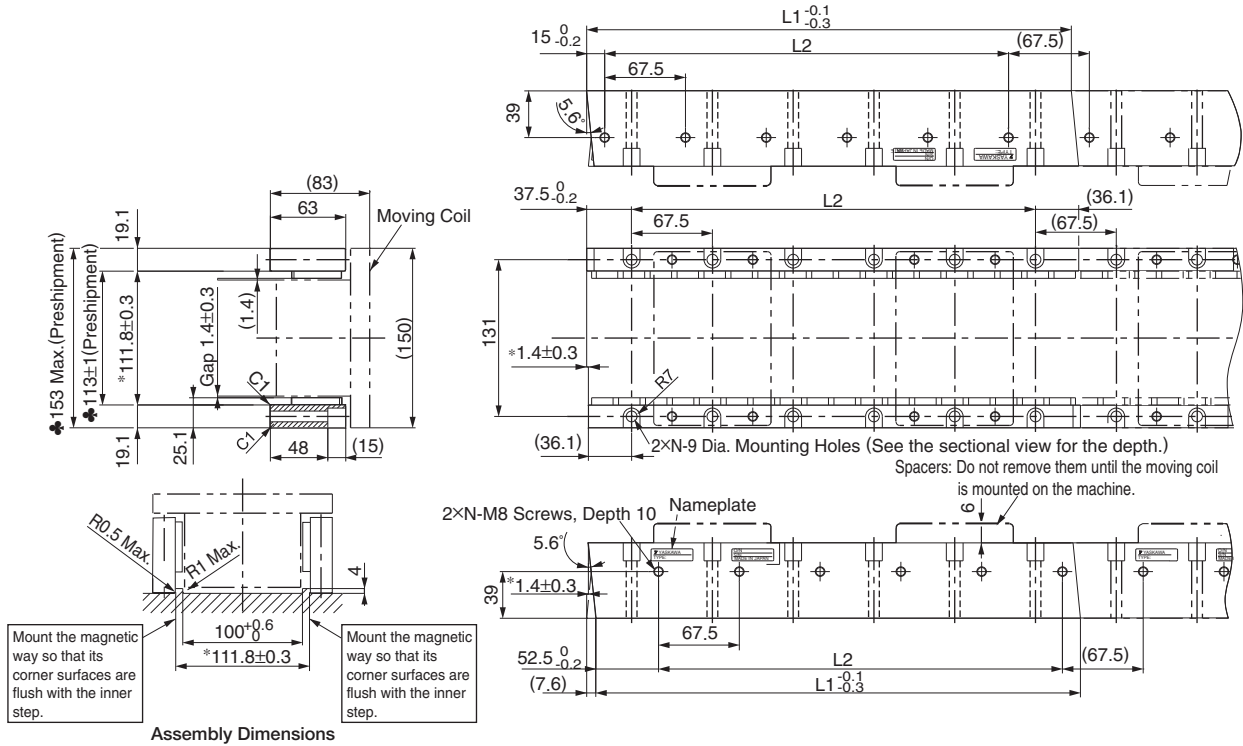

- Notes: 1 Two magnetic ways for both ends of moving coil make one set. Spacers are mounted on magnetic ways for safety during transportation. Do not remove the spacers until the moving coil is mounted on a machine.
- 2 If you have a pacemaker or any other electronic medical device, do not go near the magnetic way of the linear servomotor.
- 3 Two magnetic ways in a set can be connected to each other.
- 4 The dimensions marked with an * are the dimensions between the magnetic ways. Be sure to follow exactly the dimensions specified in the figure above. Mount magnetic ways as shown in Assembly Dimensions. The values with a ♣ are the dimensions at preshipment.
- 5 Use socket headed screws of strength class 10.9 minimum for magnetic way mounting screws. Do not use stainless steel screws.

Magnetic Way Model SGLTM-	$L1_{-0.3}^{+0.1}$	$L2$	N	Approx. Mass kg
40405A□	405	337.5 (67.5×5)	6	9
40675A□	675	607.5 (67.5×9)	10	15
40945A□	945	877.5 (67.5×13)	14	21

External Dimensions Units: mm

- Magnetic Way with Base: SGLTM-40□□□AY

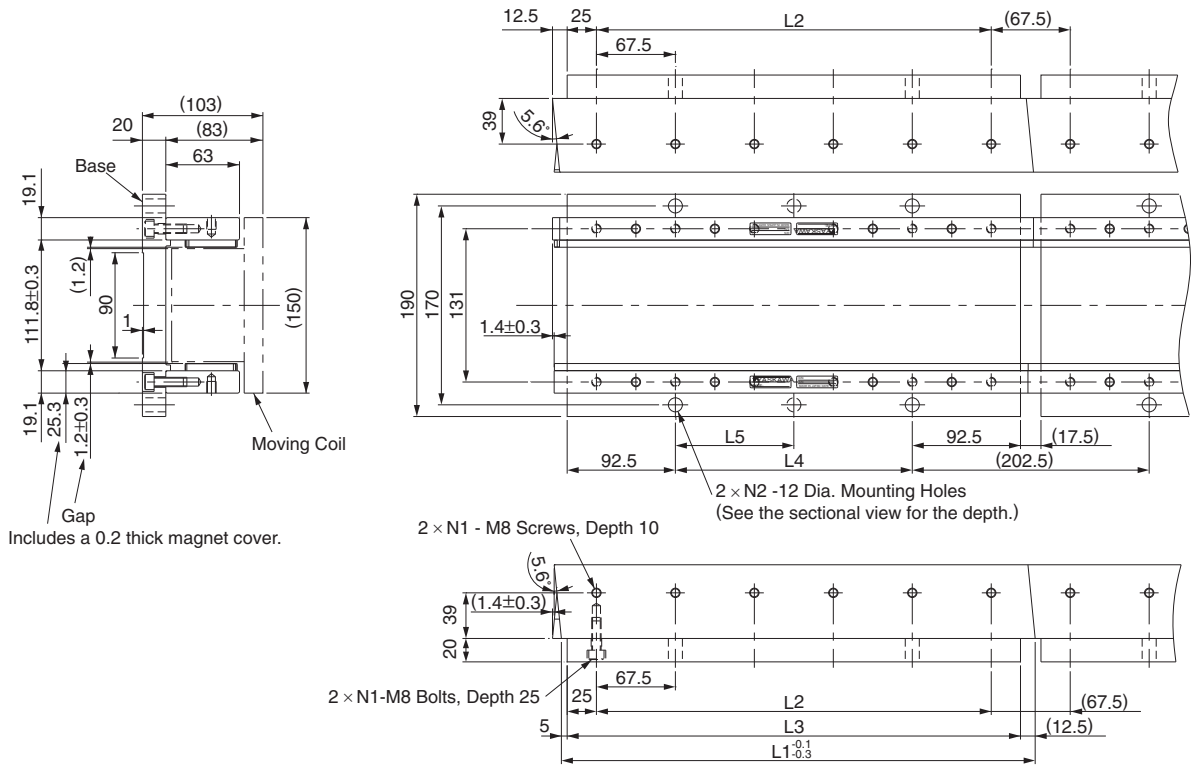

Includes a 0.2 thick magnet cover.

- Notes: 1 If you have a pacemaker or any other electronic medical device, do not go near the magnetic way of the linear servomotor.
 2 Two magnetic ways in a set can be connected to each other.
 3 The characteristics of the magnetic way with base are the same as of the magnetic way without base (SGLTM-40□□□A).

Magnetic Way Model SGLTM-	L1	L2	L3	L4	L5	N1	N2	Approx. Mass kg
40405AY	405	337.5	387.5	202.5	202.5	6	2	13
40675AY	675	607.5	657.5	472.5	236.25	10	3	21
40945AY	945	877.5	927.5	742.5	247.5	14	4	30

External Dimensions Units: mm

(4) Standard Type SGLTW-80

- Moving Coil: SGLTW-80□□□□B□ (With an MS connector)

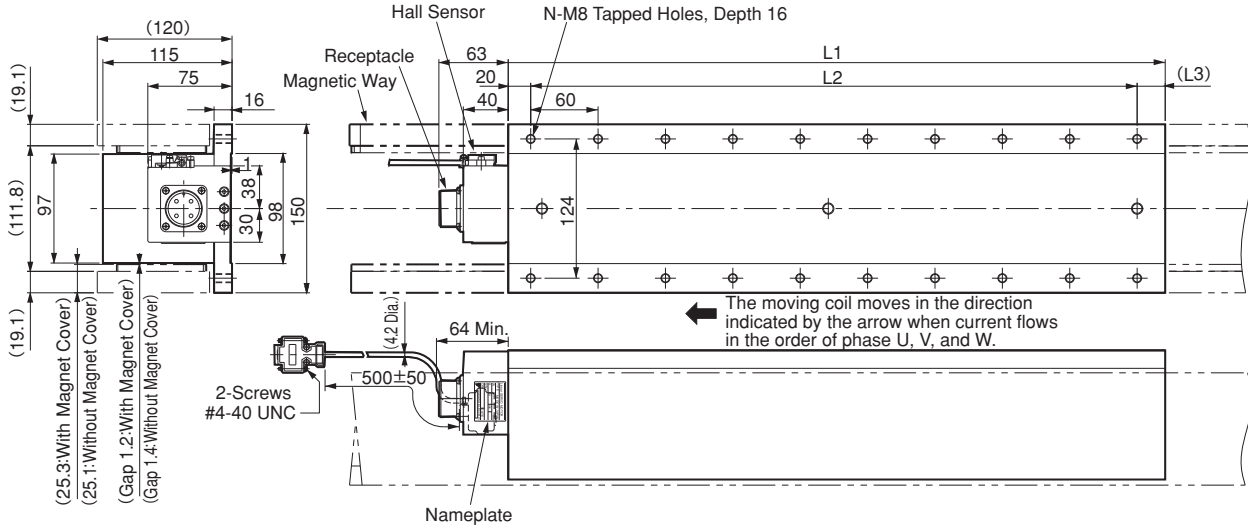

Hall Sensor Connector Specifications

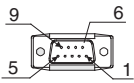

Pin Connector:
17JE-23090-02 (D8C)
by DDK Ltd.

The Mating Connector

Socket Connector:
17JE-13090-02 (D8C)
Stud: 17L-002C or
17L-002C1

Pin No.	Signal
1	+5VDC
2	Phase U
3	Phase V
4	Phase W
5	0V
6	Not used
7	Not used
8	Not used
9	Not used

Linear Servomotor Connector Specifications



Receptacle type: MS3102A-22-22P
by DDK Ltd.

The Mating Connector

L-shaped plug type : MS3108B22-22S
Straight plug type : MS3106B22-22S
Cable clamp type : MS3057-12A

Pin No.	Signal
A	Phase U
B	Phase V
C	Phase W
D	Ground

Hall Sensor Output Signals

When the moving coil moves in the direction indicated by the arrow in the figure, the relationship between the hall sensor output signals S_u , S_v , S_w and the inverse power of each motor phase V_u , V_v , V_w becomes as shown in the figure below.

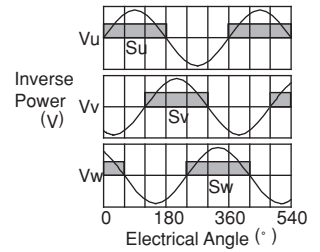

Moving Coil Model SGLTW-	L1	L2	L3	N	Approx. Mass kg
80□400B□	395	360(60×6)	(15)	14	24
80□600B□	575	540(60×9)	(15)	20	35

External Dimensions Units: mm

- Magnetic Way : SGLTM-80□□□A□

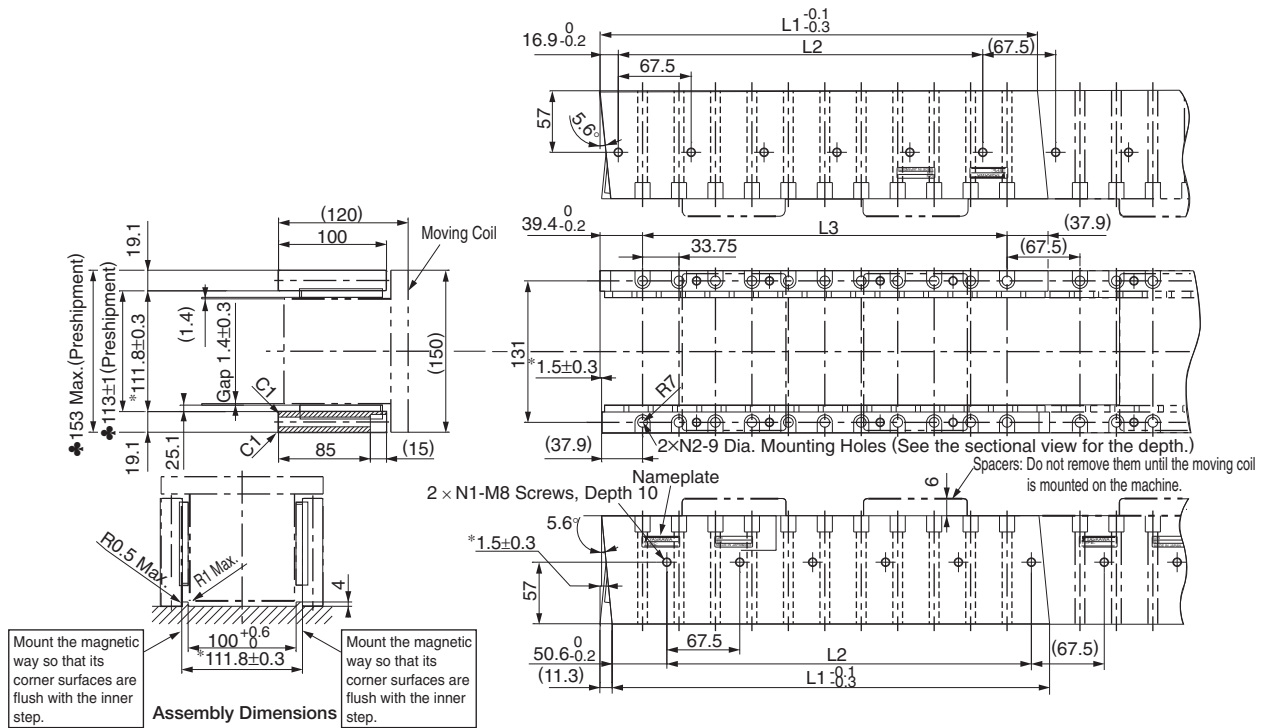

- Notes: 1 Two magnetic ways for both ends of moving coil make one set. Spacers are mounted on magnetic ways for safety during transportation. Do not remove the spacers until the moving coil is mounted on a machine.
 2 If you have a pacemaker or any other electronic medical device, do not go near the magnetic way of the linear servomotor.
 3 Two magnetic ways in a set can be connected to each other.
 4 The dimensions marked with an * are the dimensions between the magnetic ways. Be sure to follow exactly the dimensions specified in the figure above. Mount magnetic ways as shown in Assembly Dimensions. The values with a ♣ are the dimensions at preshipment.
 5 Use socket headed screws of strength class 10.9 minimum for magnetic way mounting screws. Do not use stainless steel screws.

Magnetic Way Model SGLTM-	L1 ^{-0.1} _{-0.3}	L2	L3	N1	N2	Approx. Mass kg
80405A□	405	337.5(67.5×5)	337.5(33.75×10)	6	11	14
80675A□	675	607.5(67.5×9)	607.5(33.75×18)	10	19	24
80945A□	945	877.5(67.5×13)	887.5(33.75×26)	14	27	34

External Dimensions Units: mm

• Magnetic Way with Base: SGLTM-80□□□AY

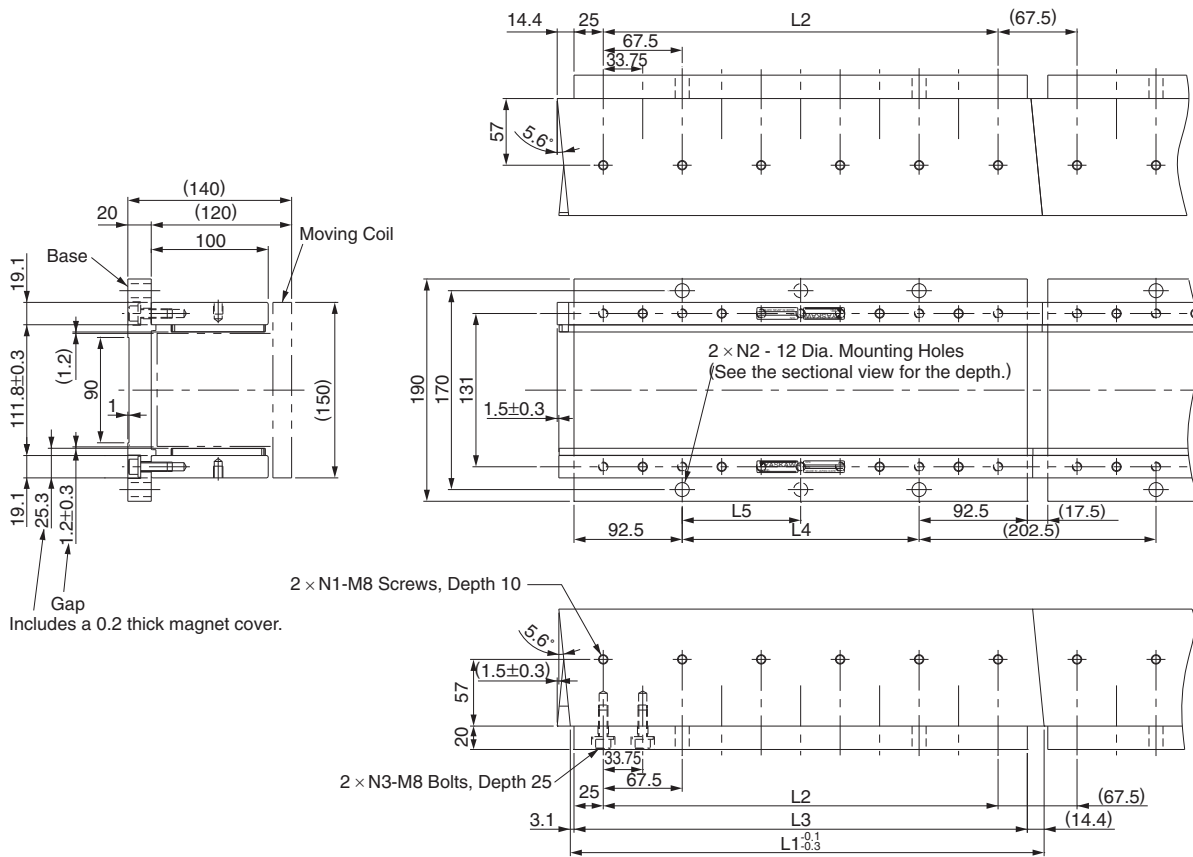

- Notes: 1 If you have a pacemaker or any other electronic medical device, do not go near the magnetic way of the linear servomotor.
 2 Two magnetic ways in a set can be connected to each other.
 3 The characteristics of the magnetic way with base are the same as of the magnetic way without base (SGLTM-80□□□A).

Magnetic Way Model SGLTM-	L1	L2	L3	L4	L5	N1	N2	N3	Approx. Mass kg
80405AY	405	337.5	387.5	202.5	202.5	6	2	11	18
80675AY	675	607.5	657.5	472.5	236.25	10	3	19	31
80945AY	945	877.5	927.5	742.5	247.5	14	4	27	43

External Dimensions Units: mm

(5) High-efficiency Type SGLTW-35A□□□H□

- Moving Coil: SGLTW-35A□□□H□ (With a connector by Tyco Electronics AMP K.K.)

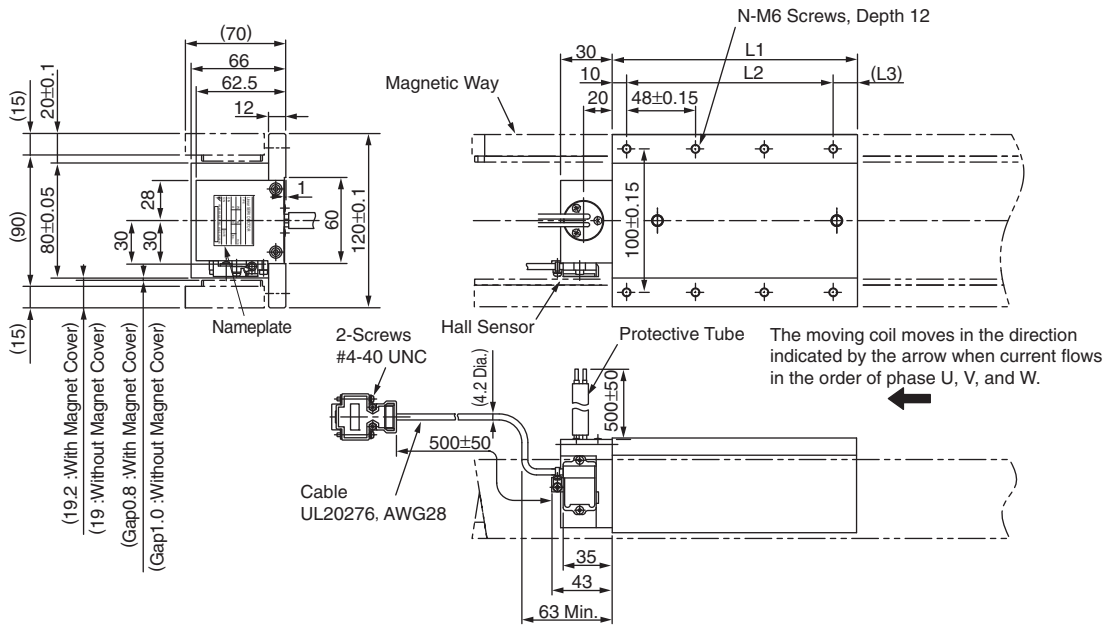

Hall Sensor Connector Specifications

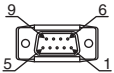

Pin Connector:
 17JE-23090-02 (D8C)
 by DDK Ltd.

The Mating Connector
 Socket Connector:
 17JE-13090-02 (D8C)
 Stud: 17L-002C or
 17L-002C1

Pin No.	Signal
1	+5VDC
2	Phase U
3	Phase V
4	Phase W
5	0V
6	Not used
7	Not used
8	Not used
9	Not used

Lead Specifications of Moving Coil

• If this cable is bent repetitively, the cable will disconnect.

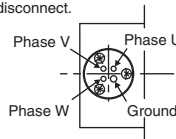

(View from Top of Moving Coil)

Name	Color	Code	Wire Size
Phase U		U	2 mm ²
Phase V	Black	V	
Phase W		W	
Ground	Green	-	2 mm ²

Hall Sensor Output Signals

When the moving coil moves in the direction indicated by the arrow in the figure, the relationship between the hall sensor output signals S_u , S_v , S_w and the inverse power of each motor phase V_u , V_v , V_w becomes as shown in the figure below.

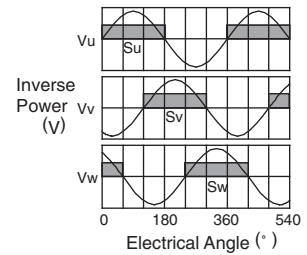

Moving Coil Model SGLTW-	L1	L2	(L3)	N	Approx. Mass kg
35A170H□	170	144 (48×3)	(16)	8	4.7
35A320H□	315	288 (48×6)	(17)	14	8.8

External Dimensions Units: mm

- Moving Coil: SGLTW-35D□□□H□D (With a connector by Interconnectron GmbH)

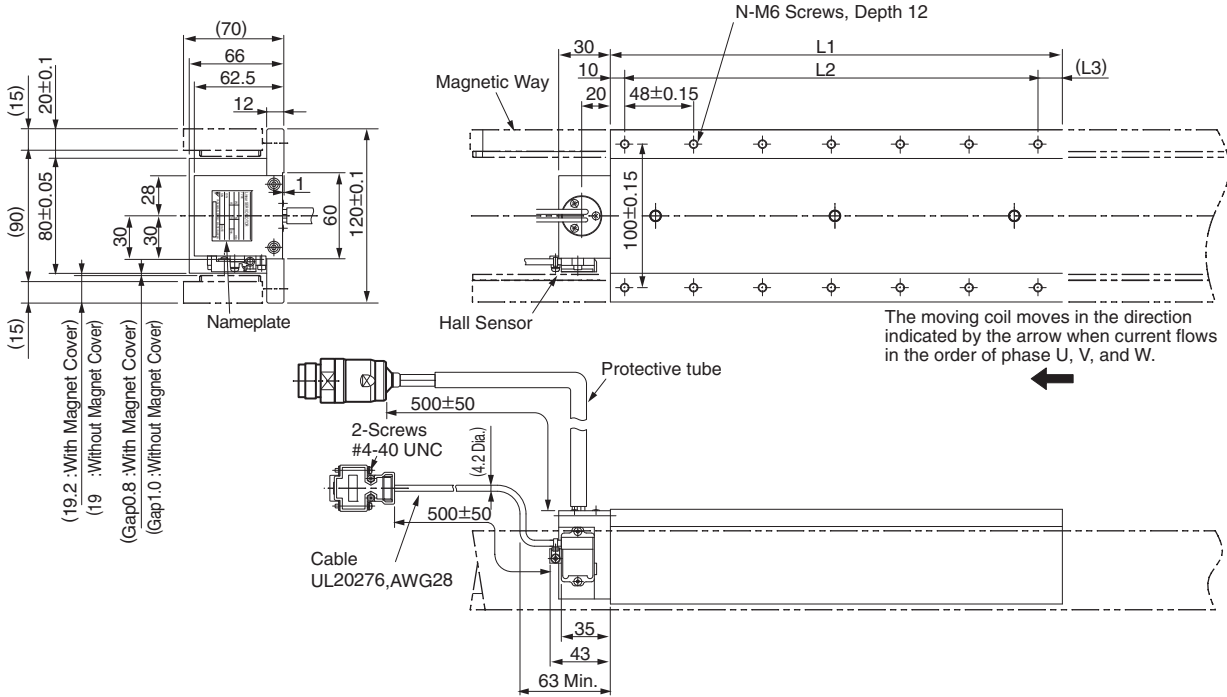

The moving coil moves in the direction indicated by the arrow when current flows in the order of phase U, V, and W.

Hall Sensor Connector Specifications

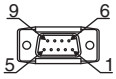

Pin Connector:
17JE-23090-02 (D8C)
by DDK Ltd.

The Mating Connector

Socket Connector:
17JE-13090-02 (D8C)
Stud: 17L-002C or
17L-002C1

Pin No.	Signal
1	+5VDC
2	Phase U
3	Phase V
4	Phase W
5	0V
6	Not used
7	Not used
8	Not used
9	Not used

Linear Servomotor Connector Specifications



Extension : ARRA06AMRPN182
Pin : 021.279.1020
by Interconnectron GmbH

The Mating Connector

Plug : APRA06BFRDN170
Socket : 020.105.1020

Pin No.	Signal
1	Phase U
2	Phase V
4	Phase W
5	Not used
6	Not used
⊕	Ground

Hall Sensor Output Signals

When the moving coil moves in the direction indicated by the arrow in the figure, the relationship between the hall sensor output signals S_u , S_v , S_w and the inverse power of each motor phase V_u , V_v , V_w becomes as shown in the figure below.

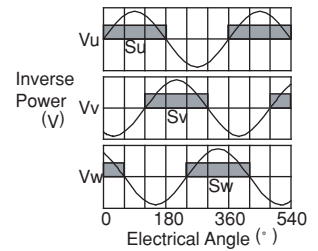

Moving Coil Model SGLTW-	L1	L2	(L3)	N	Approx. Mass kg
35D170H□D	170	144(48×3)	(16)	8	4.7
35D320H□D	315	288(48×6)	(17)	14	8.8

External Dimensions Units: mm

- Magnetic Way: SGLTM-35□□□H□

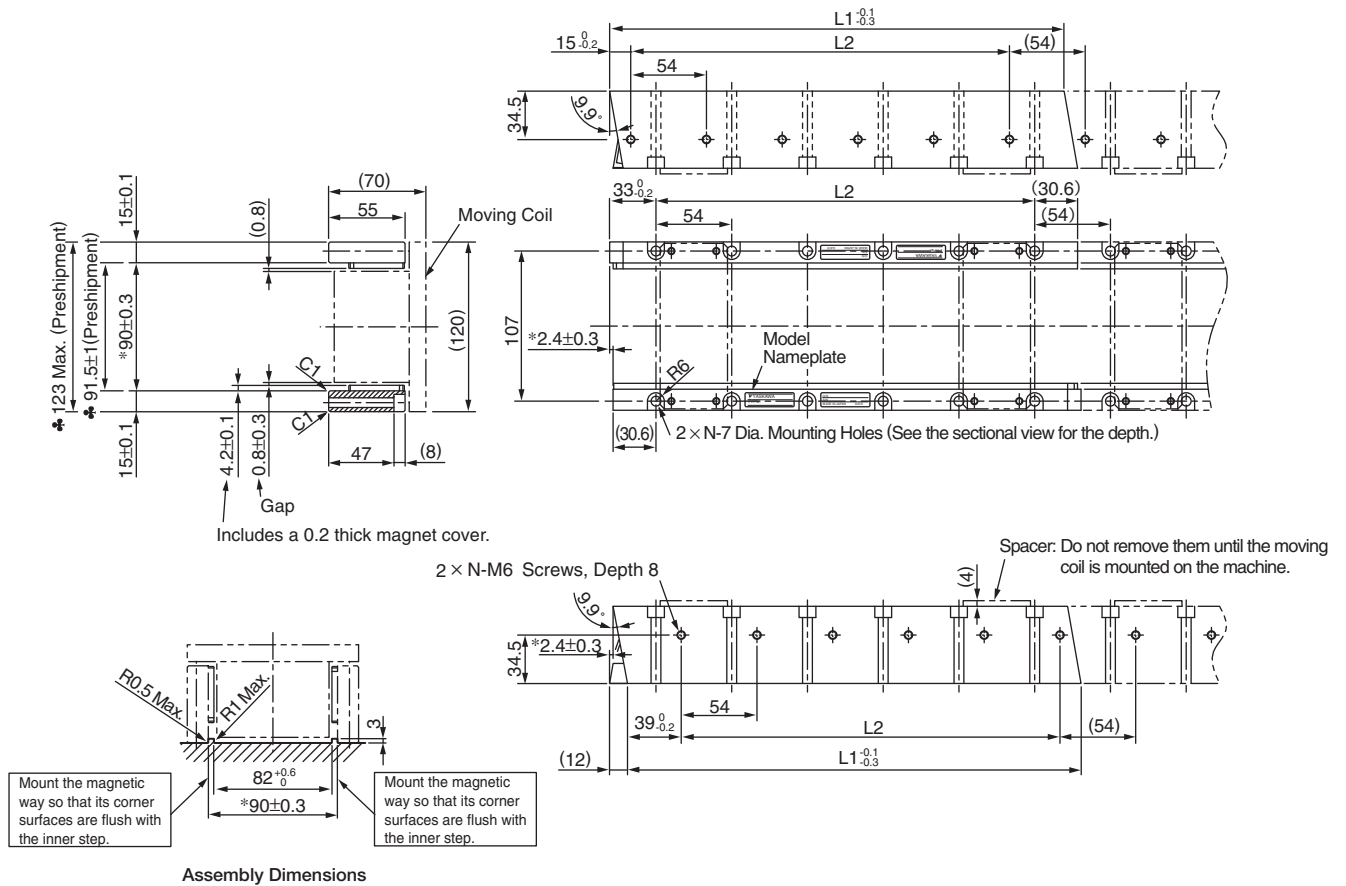

- Notes: 1 Two magnetic ways for both ends of moving coil make one set. Spacers are mounted on magnetic ways for safety during transportation. Do not remove the spacers until the moving coil is mounted on a machine.
 2 If you have a pacemaker or any other electronic medical device, do not go near the magnetic way of the linear servomotor.
 3 Two magnetic ways in a set can be connected to each other.
 4 The dimensions marked with an * are the dimensions between the magnetic ways. Be sure to follow exactly the dimensions specified in the figure above. Mount magnetic ways as shown in Assembly Dimensions. The values with a ♣ are the dimensions at preshipment.
 5 Use socket headed screws of strength class 10.9 minimum for magnetic way mounting screws. Do not use stainless steel screws.

Magnetic Way Model SGLTM-	L1 ^{-0.1} _{-0.3}	L2	N	Approx. Mass kg
35324H□	324	270 (54×5)	6	4.8
35540H□	540	486 (54×9)	10	8
35756H□	756	702 (54×13)	14	11

External Dimensions Units: mm

(6) High-efficiency Type SGLTW-50

- Moving Coil: SGLTW-50A□□□H□ (With a connector by Tyco Electronics AMP K.K.)

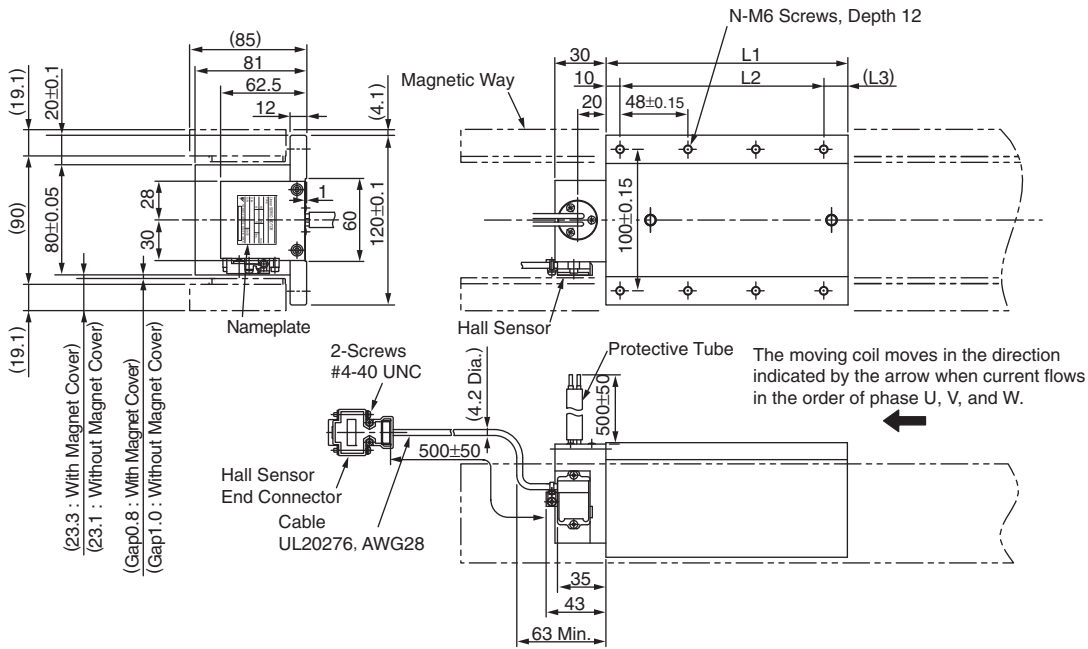

Hall Sensor Connector Specifications

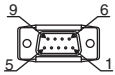

Pin Connector:
17JE-23090-02 (D8C)
by DDK Ltd.

The Mating Connector
Socket Connector:
17JE-13090-02 (D8C)
Stud: 17L-002C or
17L-002C1

Pin No.	Signal
1	+5VDC
2	Phase U
3	Phase V
4	Phase W
5	0V
6	Not used
7	Not used
8	Not used
9	Not used

Lead Specifications of Moving Coil

- If this cable is bent repetitively, the cable will disconnect.

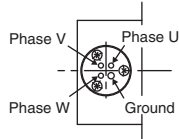

(View from Top of Moving Coil)

Name	Color	Code	Wire Size
Phase U		U	2 mm ²
Phase V	Black	V	2 mm ²
Phase W		W	2 mm ²
Ground	Green	-	2 mm ²

Hall Sensor Output Signals

When the moving coil moves in the direction indicated by the arrow in the figure, the relationship between the hall sensor output signals S_u , S_v , S_w and the inverse power of each motor phase V_u , V_v , V_w becomes as shown in the figure below.

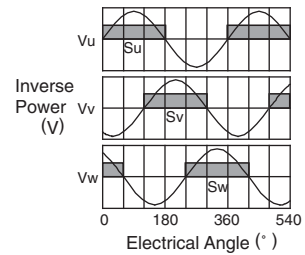

Moving Coil Model SGLTW-	L1	L2	(L3)	N	Approx. Mass kg
50A170H□	170	144 (48×3)	(16)	8	6
50A320H□	315	288 (48×6)	(17)	14	11

External Dimensions Units: mm

- Moving Coil: SGLTW-50D□□□H□D (With a connector by Interconnectron GmbH)

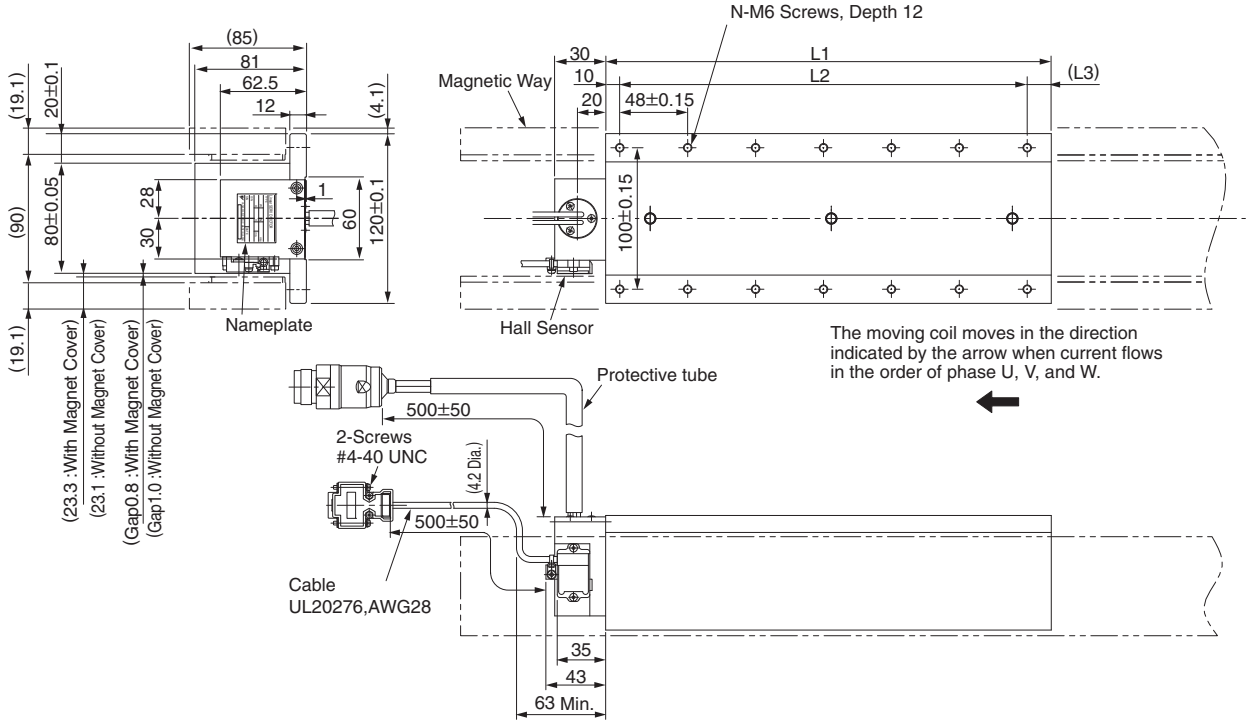

The moving coil moves in the direction indicated by the arrow when current flows in the order of phase U, V, and W.

Hall Sensor Connector Specifications

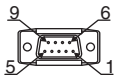

Pin Connector:
 17JE-23090-02 (D8C)
 by DDK Ltd.

The Mating Connector

Socket Connector:
 17JE-13090-02 (D8C)
 Stud: 17L-002C or
 17L-002C1

Pin No.	Signal
1	+5VDC
2	Phase U
3	Phase V
4	Phase W
5	0V
6	Not used
7	Not used
8	Not used
9	Not used

Linear Servomotor Connector Specifications



Extension : ARRA06AMRPN182
 Pin : 021.279.1020
 by Interconnectron GmbH

The Mating Connector

Plug : APRA06BFRDN170
 Socket : 020.105.1020

Pin No.	Signal
1	Phase U
2	Phase V
4	Phase W
5	Not used
6	Not used
⊕	Ground

Hall Sensor Output Signals

When the moving coil moves in the direction indicated by the arrow in the figure, the relationship between the hall sensor output signals Su, Sv, Sw and the inverse power of each motor phase Vu, Vv, Vw becomes as shown in the figure below.

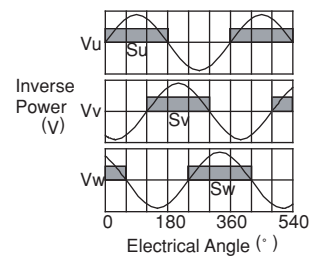

Moving Coil Model SGLTW-	L1	L2	(L3)	N	Approx. Mass kg
50D170H□D	170	144(48×3)	(16)	8	6
50D320H□D	315	288(48×6)	(17)	14	11

External Dimensions Units: mm

- Magnetic Way: SGLTM-50□□□H□

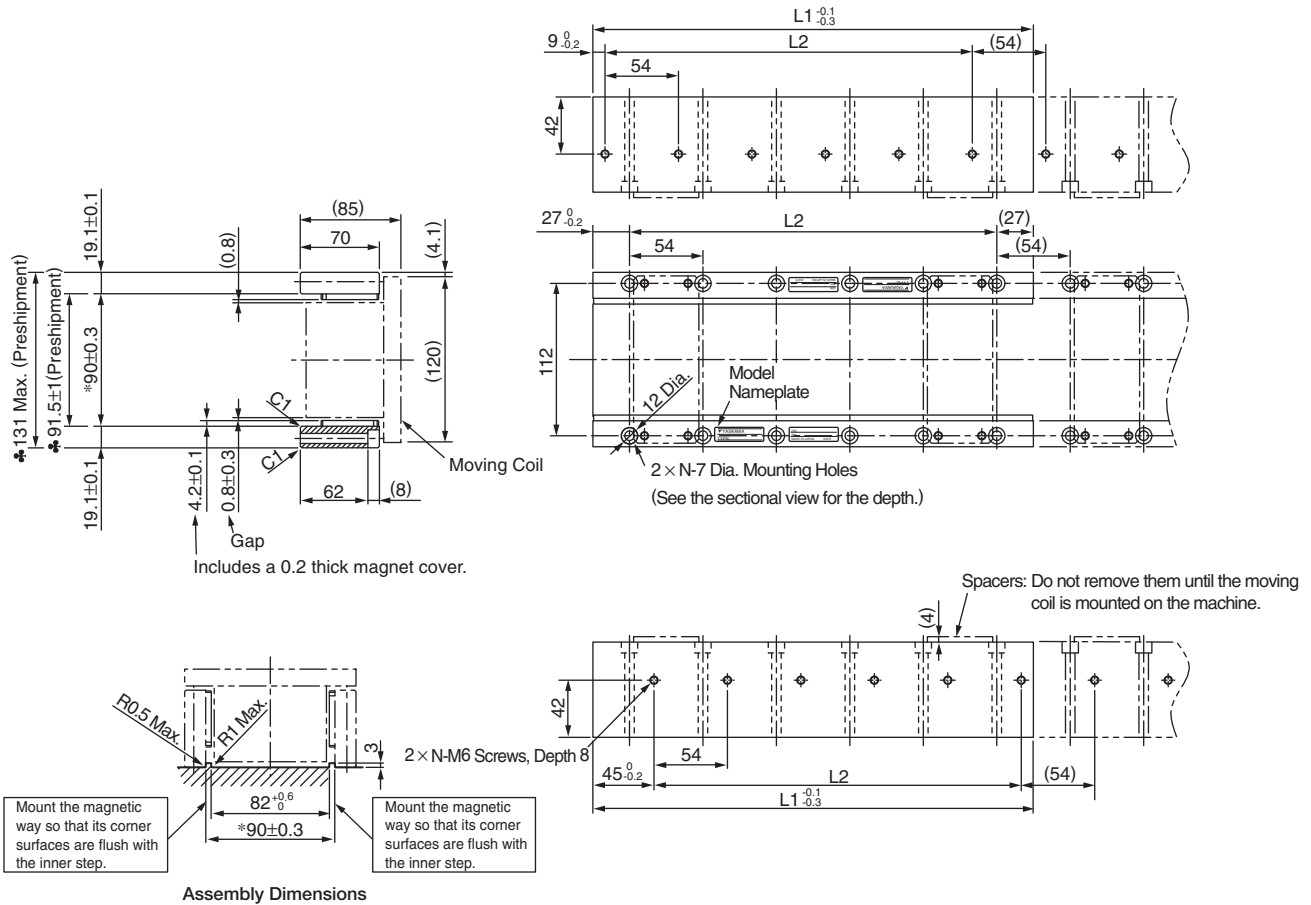

- Notes: 1 Two magnetic ways for both ends of moving coil make one set. Spacers are mounted on magnetic ways for safety during transportation. Do not remove the spacers until the moving coil is mounted on a machine.
 2 If you have a pacemaker or any other electronic medical device, do not go near the magnetic way of the linear servomotor.
 3 Two magnetic ways in a set can be connected to each other.
 4 The dimensions marked with an * are the dimensions between the magnetic ways. Be sure to follow exactly the dimensions specified in the figure above. Mount magnetic ways as shown in Assembly Dimensions. The values with a ♣ are the dimensions at preshipment.
 5 Use socket headed screws of strength class 10.9 minimum for magnetic way mounting screws. Do not use stainless steel screws.

Magnetic Way Model SGLTM-	L1 ^{-0.1} / _{-0.3}	L2	N	Approx. Mass kg
50324H□	324	270 (54×5)	6	8
50540H□	540	486 (54×9)	10	13
50756H□	756	702 (54×13)	14	18

Selecting Cables

● Cables Connections

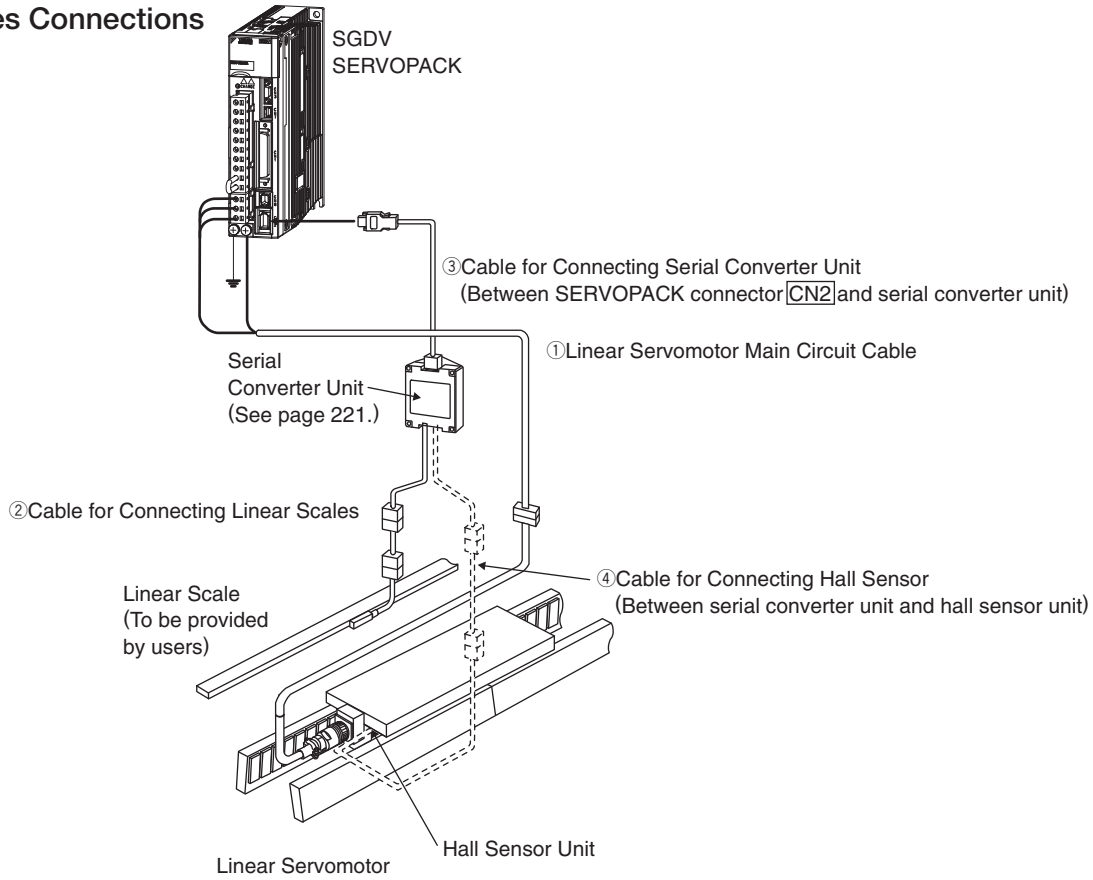



● Cables

Name	Applicable Linear Servomotor Model	Length	Order No.	Specifications	Details
① Linear Servomotor Main Circuit Cables	SGLTW -20, -35, -50	1 m	JZSP-CLN21-01-E		(1)
		3 m	JZSP-CLN21-03-E		
		5 m	JZSP-CLN21-05-E		
		10 m	JZSP-CLN21-10-E		
		15 m	JZSP-CLN21-15-E		
		20 m	JZSP-CLN21-20-E		
	SGLTW-40, -80	1 m	JZSP-CLN39-01-E		(2)
		3 m	JZSP-CLN39-03-E		
		5 m	JZSP-CLN39-05-E		
		10 m	JZSP-CLN39-10-E		
		15 m	JZSP-CLN39-15-E		
		20 m	JZSP-CLN39-20-E		
	SGLTW- □□A□□□□□D	1 m	JZSP-CLN14-01-E		(3)
		3 m	JZSP-CLN14-03-E		
		5 m	JZSP-CLN14-05-E		
		10 m	JZSP-CLN14-10-E		
		15 m	JZSP-CLN14-15-E		
		20 m	JZSP-CLN14-20-E		
	SGLTW- □□D□□□□□D	1 m	JZSP-CLN15-01-E		(4)
		3 m	JZSP-CLN15-03-E		
		5 m	JZSP-CLN15-05-E		
		10 m	JZSP-CLN15-10-E		
		15 m	JZSP-CLN15-15-E		
		20 m	JZSP-CLN15-20-E		

*1: Connector by Tyco Electronics AMP K.K.
 *2: MS connector
 *3: Connector by Interconnectron GmbH

(cont'd)

Selecting Cables

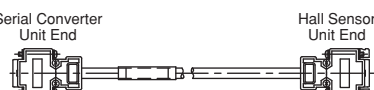
Name	Applicable Linear Servomotor Model	Length	Order No.	Specifications	Details
② Cables for Connecting Linear Scales*	All models	1 m	JZSP-CLL00-01-E		(5)
		3 m	JZSP-CLL00-03-E		
		5 m	JZSP-CLL00-05-E		
		10 m	JZSP-CLL00-10-E		
		15 m	JZSP-CLL00-15-E		
③ Cables for Connecting Serial Converter Units	All models	1 m	JZSP-CLP70-01-E		(6)
		3 m	JZSP-CLP70-03-E		
		5 m	JZSP-CLP70-05-E		
		10 m	JZSP-CLP70-10-E		
		20 m	JZSP-CLP70-20-E		
④ Cables for Connecting Hall Sensors	All models	1 m	JZSP-CLL10-01-E		(7)
		3 m	JZSP-CLL10-03-E		
		5 m	JZSP-CLL10-05-E		
		10 m	JZSP-CLL10-10-E		
		15 m	JZSP-CLL10-15-E		

*: When using serial converter unit JZDP-G00□-□□□-E, the maximum cable length should be 3 m.

(1) Linear Servomotor Main Circuit Cables: JZSP-CLN21-□□-E

· Wiring Specifications

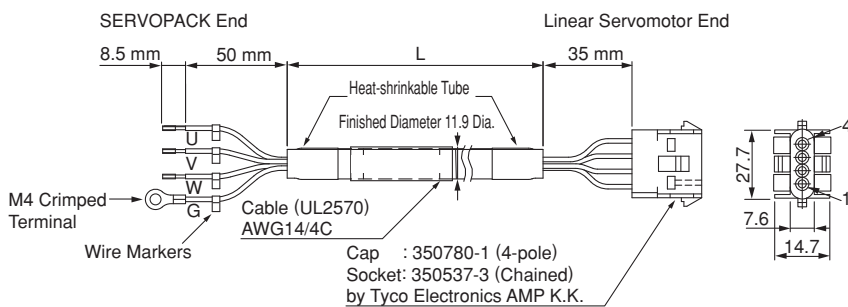

SERVOPACK-end Leads		Linear Servomotor-end Connector	
Wire Color	Signal	Signal	Pin No.
Red	Phase U	Phase U	1
White	Phase V	Phase V	2
Blue	Phase W	Phase W	3
Green/yellow	FG	FG	4

(2) Linear Servomotor Main Circuit Cables: JZSP-CLN39-□□-E

A connector is not provided on the linear-servomotor end of the main circuit cable (JZSP-CLN39-□□-E). This connector is provided by the customer.

· Wiring Specifications

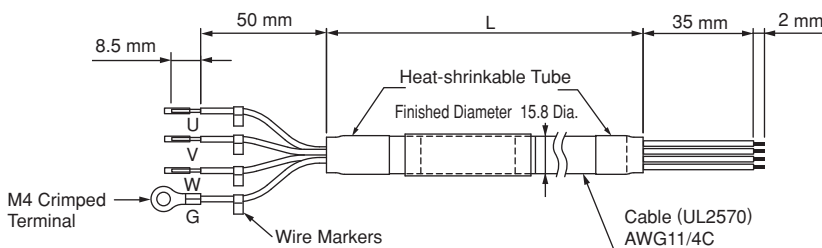

SERVOPACK-end Leads		Linear Servomotor-end Connector	
Wire Color	Signal	Signal	Pin No.
Red	Phase U	Phase U	1
White	Phase V	Phase V	2
Blue	Phase W	Phase W	3
Green/yellow	FG	FG	4

Selecting Cables

●JZSP-CLN39 Cable Connectors

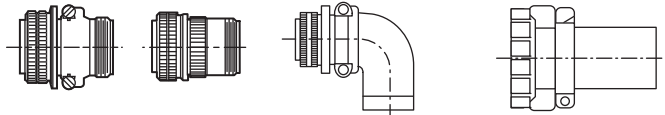

Applicable Linear Servomotor Model	Attached Connector	Plug		Cable Clamp
		Straight	Straight L-shaped	
SGLTW-40, -80	MS3102A22-22P	MS3106B22-22S or MS3106A22-22A	MS3108B22-22S	MS3057-12A

(a) MS3106B: Straight Plug with Front-shell and Back-shell Separated

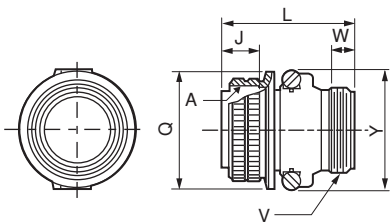

Units: mm

Shell Size	Joint Screw A	Joint Length J±0.12	Max. Overall Length L	Outer Diameter of Nut Q ⁺⁰ _{-0.38}	Cable Clamp Mounting Screw V	Min. Effective Screw Length W	Max. Width Y
22	1 3/8 -18UNEF	18.26	55.57	40.48	1 3/16 -18UNEF	9.53	50

(b) MS3106A: Straight Plug with Solid Shell

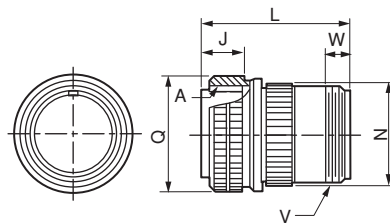

Units: mm

Shell Size	Joint Screw A	Joint Length J±0.12	Overall Length L±0.5	Outer Diameter of Nut Q ⁺⁰ _{-0.38}	Outer Diameter N±0.5	Cable Clamp Mounting Screw V	Min. Effective Screw Length W
22	1 3/8 -18UNEF	18.26	54	40.48	34.99	1 3/16-18UNEF	9.53

(c) MS3108B: L-shaped Plug with Front-shell and Back-shell Separated

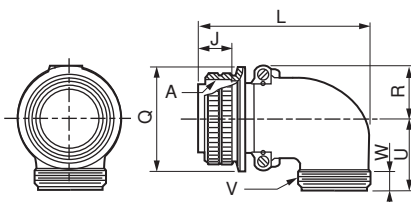

Units: mm

Shell Size	Joint Screw A	Joint Length J±0.12	Max. Overall Length L	R ±0.5	U ±0.5	Outer Diameter of Nut Q ⁺⁰ _{-0.38}	Cable Clamp Mounting Screw V	Min. Effective Screw Length W
22	1 3/8 -18UNEF	18.26	76.98	24.1	33.3	40.48	1 3/16 -18UNEF	9.53

(d) MS3057-12A: Cable Clamp with Rubber Bushing

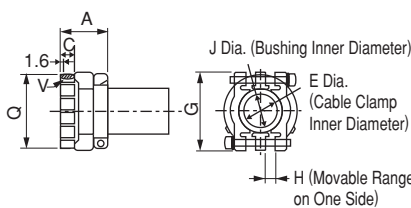

Units: mm

Applicable Shell Size	Overall Length A±0.7	Effective Screw Length C	E	G±0.7	H	J	Mounting Screw V	Outer Diameter Q±0.7	Rubber Bushing Type
20,22	23.8	10.3	19.0	37.3	4.0	15.9	1 3/16 -18UNEF	35.0	AN3420 -12

Linear Servomotors

Selecting Cables

(3) Linear Servomotor Main Circuit Cables: JZSP-CLN14-□□-E

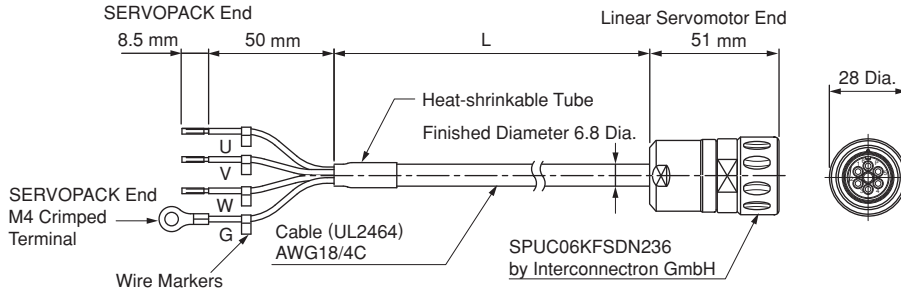

• Wiring Specifications

SERVOPACK-end Leads		Linear Servomotor-end Connector	
Wire Color	Signal	Signal	Pin No.
Black (White 1)	Phase U	Phase U	1
Black (White 2)	Phase V	Phase V	2
Black (White 3)	Phase W	Phase W	3
Green / yellow	FG	—	4
		—	5
		FG	6

(4) Linear Servomotor Main Circuit Cables: JZSP-CLN15-□□-E

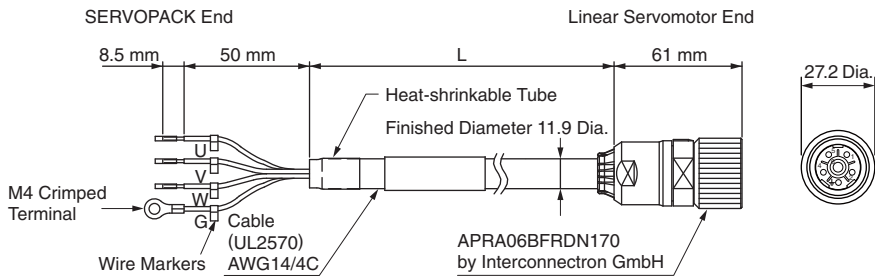

• Wiring Specifications

SERVOPACK-end Leads		Linear Servomotor-end Connector	
Wire Color	Signal	Signal	Pin No.
Red	Phase U	Phase U	1
White	Phase V	Phase V	2
Black	Phase W	FG	3
Green / yellow	FG	Phase W	4
		—	5
		—	6

(5) Cables for Connecting Linear Scales: JZSP-CLL00-□□-E

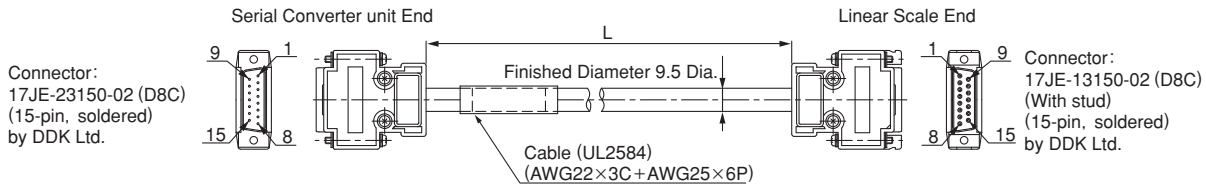

• Wiring Specifications

Serial Converter Unit End		Linear Scale End	
Pin No.	Signal	Pin No.	Signal
1	/Cos(V1-)	1	/Cos(V1-)
2	/Sin(V2-)	2	/Sin(V2-)
3	Ref(V0+)	3	Ref(V0+)
4	+5V	4	+5V
5	5Vs	5	5Vs
6	BID	6	BID
7	Vx	7	Vx
8	Vq	8	Vq
9	Cos(V1+)	9	Cos(V1+)
10	Sin(V2+)	10	Sin(V2+)
11	/Ref(V0+)	11	/Ref(V0-)
12	0V	12	0V
13	0Vs	13	0Vs
14	DIR	14	DIR
15	Inner	15	Inner
Case	Shield	Case	Shield

Selecting Cables

(6) Cables for Connecting Serial Converter Units: JZSP-CLP70-□□-E

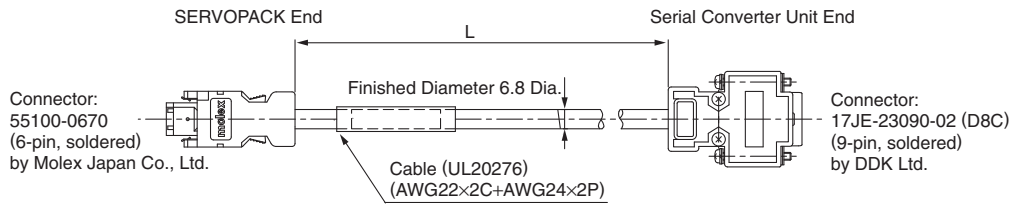

• Wiring Specifications

SERVOPACK End			Serial Converter Unit End		
Pin No.	Signal	Wire Color	Pin No.	Signal	Wire Color
1	PG5V	Red	1	+5V	Red
2	PG0V	Black	5	0V	Black
3	—	—	3	—	—
4	—	—	4	—	—
5	PS	Light blue	2	Phase S output	Light blue
6	/PS	Light blue/white	6	Phase /S output	Light blue/white
Shell	Shield	—	Case	Shield	—
			7	—	—
			8	—	—
			9	—	—

(7) Cables for Connecting Hall Sensors: JZSP-CLL10-□□-E

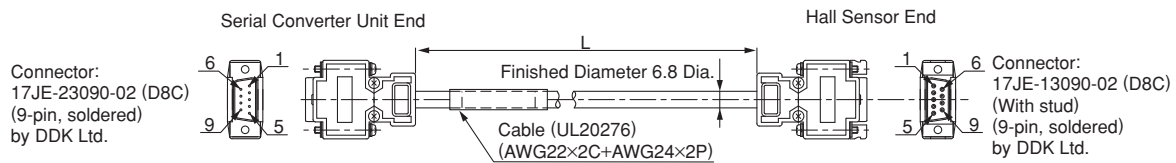

• Wiring Specifications

Serial Converter Unit End		Hall Sensor End	
Pin No.	Signal	Pin No.	Signal
1	+5V	1	+5V
2	Phase U input	2	Phase U input
3	Phase V input	3	Phase V input
4	Phase W input	4	Phase W input
5	0V	5	0V
6	—	6	—
7	—	7	—
8	—	8	—
9	—	9	—
Case	Shield	Case	Shield

Linear Servomotors

SGLC

(Cylinder Type)



Model Designations

● Combination of Moving Coil and Magnetic Way

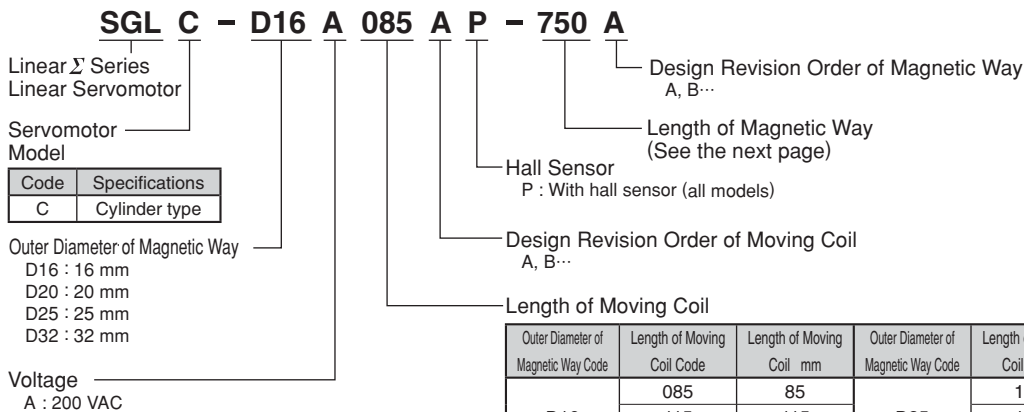

Outer Diameter of Magnetic Way Code	Length of Moving Coil Code	Length of Moving Coil mm	Outer Diameter of Magnetic Way Code	Length of Moving Coil Code	Length of Moving Coil mm
D16	085	85	D25	125	125
	115	115		170	170
	145	145		215	215
D20	100	100	D32	165	165
	135	135		225	225
	170	170		285	285

● Moving Coil

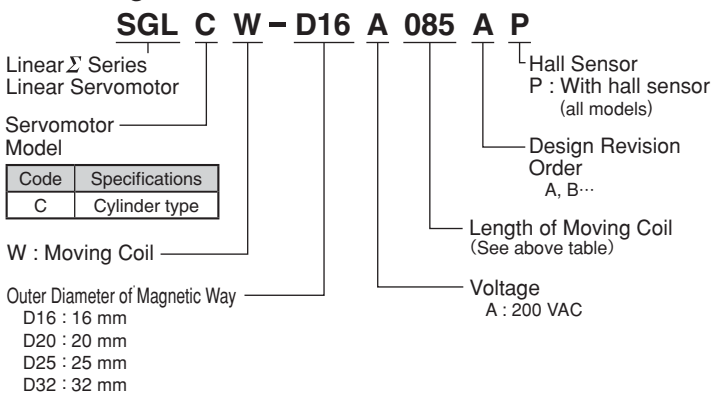

● Magnetic Way

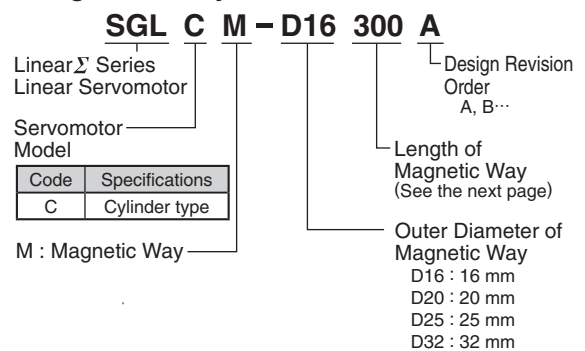

Note: Order the moving coil and magnetic way as a set. Contact your Yaskawa representative before purchasing them separately.

Features

- Both coil assemblies supported, easy switching from ball screws.
- Compared to ball screw systems, high-speed and high-precision positioning greatly reduces tact time.
- Unlike ball screws, no contact with machines, no lubrication oil, easy maintenance.

Application Examples

- Semiconductor equipment
- Electronic parts assembly
- Food packaging machines
- Metal processing machines
- General handling machines

◆ Magnetic Way Lengths

Moving Coil Model SGLCW-		Magnetic Way Dimensions mm					Length of Magnetic Way mm Min. to Max.
		Standard Specifications				Special Orders	
		Code=① mm					
②	③	④	⑤				
D16A	085AP 115AP 145AP	300	85	30	37.5	140	240 to 420 (30 mm increments)
			115			110	
			145			80	
	510	85	45	52.5	320	480 to 750 (30 mm increments)	
		115			290		
		145			260		
		85			560		
		115			530		
		145			500		
D20A	100AP 135AP 170AP	350	100	35	45	160	280 to 490 (35 mm increments)
			135			125	
			170			90	
	590	100	50	60	370	555 to 870 (35 mm increments)	
		135			335		
		170			300		
		100			650		
		135			615		
		170			580		
D25A	125AP 170AP 215AP	450	125	45	57.5	210	360 to 630 (45 mm increments)
			170			165	
			215			120	
	750	125	60	72.5	480	705 to 1110 (45 mm increments)	
		170			435		
		215			390		
		125			840		
		170			795		
		215			750		
D32A	165AP 225AP 285AP	600	165	60	75	285	480 to 840 (60 mm increments)
			225			225	
			285			165	
	1020	165	90	105	645	960 to 1500 (60 mm increments)	
		225			585		
		285			525		
		165			1125		
		225			1065		
		285			1005		

- ① Length of Magnetic Way
- ② Length of Moving Coil
- ③ Position of Support Section
- ④ Range Outside the Guaranteed Force
- ⑤ Effective Strokes

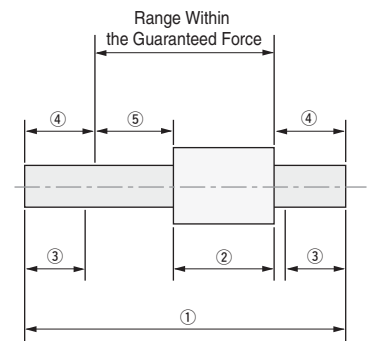

Note: ④ Range outside the guaranteed force: If any part of the moving coil is located within this range, characteristics indicated in *Force and Speed Characteristics* on page 210 cannot be satisfied.

< Calculating Length of Magnetic Way >

- ② Length of Moving Coil (mm)
- ④ Range Outside the Guaranteed Force (mm)
- ⑤ Effective Strokes (mm)

Formula

◆ Length of Magnetic Way
 $[(2) + (4) \times 2 + (5)]$ (mm)

Ratings and Specifications

Time Rating: Continuous

Insulation Resistance: 500 VDC, 10 MΩ min.

Ambient Temperature: 0 to 40°C

Excitation: Permanent magnet

Withstand Voltage: 1500 VAC for one minute

Enclosure: Self-cooled

Ambient Humidity: 20% to 80% (no condensation)

Allowable Winding Temperature: 130°C (Thermal class B)

Linear Servomotor Model SGLC-		D16A			D20A			D25A			D32A		
		085A	115A	145A	100A	135A	170A	125A	170A	215A	165A	225A	285A
Peak Speed* ³	m / s	4.0	4.0	4.0	4.0	4.0	4.0	4.0	4.0	4.0	4.0	4.0	4.0
Rated Force* ¹	N	17	25	34	30	45	60	70	105	140	90	135	180
Rated Current* ¹	Arms	0.59	0.53	0.66	0.98	0.98	1.19	1.42	1.75	3.49	1.57	2.79	2.79
Instantaneous Peak Force* ¹	N	60	90	120	150	225	300	280	420	560	420	630	840
Instantaneous Peak Current* ¹	Arms	2.07	2.07	2.52	4.90	4.90	5.95	5.68	6.98	12.96	7.32	13.01	13.01
Moving Coil Mass	kg	0.3	0.4	0.5	0.6	0.8	1.0	1.0	1.4	1.8	1.8	2.5	3.2
Force Constant	N / Arms	31.2	46.8	51.3	33.0	49.5	54.3	53.1	64.8	43.2	61.8	52.2	69.6
BEMF Constant	V / (m/s)	10.4	15.6	17.1	11.0	16.5	18.1	17.7	21.6	14.4	20.6	17.4	23.2
Motor Constant	N / \sqrt{w}	4.8	5.9	6.7	7.5	9.2	10.4	10.0	12.4	15.4	16.2	20.0	23.0
Electrical Time Constant	ms	0.18	0.18	0.17	0.38	0.32	0.41	0.18	0.59	0.65	0.76	1.18	1.58
Mechanical Time Constant	ms	13.1	11.7	11.3	10.70	9.50	9.30	10.1	9.2	7.6	6.9	6.3	6.0
Thermal Resistance With Heat Sink	K / W	3.35	2.9	1.64	1.66	1.45	1.29	1.00	0.68	0.61	0.77	0.53	0.49
Thermal Resistance Without Heat Sink	K / W	6.79	5.24	4.26	4.35	3.38	2.76	2.99	2.29	1.81	1.87	1.43	1.16
Magnetic Attraction* ²	N	0	0	0	0	0	0	0	0	0	0	0	0
Applicable SERVOPACK	SGDV-	R70A	R70A	R90A	1R6A	1R6A	2R8A	1R6A	2R8A	5R5A	2R8A	5R5A	5R5A

*1: These items and "Force and Speed Characteristics" are the values at a motor winding temperature of 100°C during operation in combination with a SERVOPACK. The others are at 20°C.

*2: Logical magnetic attraction acting between the moving coil and the magnetic way. Because of the gap imbalance created after installing the moving coil and the magnetic way, a magnetic attraction is generated.

*3: The rated speed during operation by speed control with an analog voltage reference must be set to 1.5 m/s.

Note: These specifications show the values under the cooling conditions when a heat sink (aluminum board) listed in the following table is mounted on the moving coil.

Heat Sink Size	Applicable Models
100 mm×200 mm×12 mm	SGLC-D16A085A, -D16A115A
200 mm×300 mm×12 mm	SGLC-D16A145A, -D20A100A, -D20A135A, -D20A170A
300 mm×400 mm×12 mm	SGLC-D25A125A, -D32A165A
400 mm×500 mm×12 mm	SGLC-D25A170A, -D25A215A, -D32A225A, -D32A285A

Ratings and Specifications

● **Force and Speed Characteristics** [A] : Continuous Duty Zone [B] : Intermittent Duty Zone ^(Note)

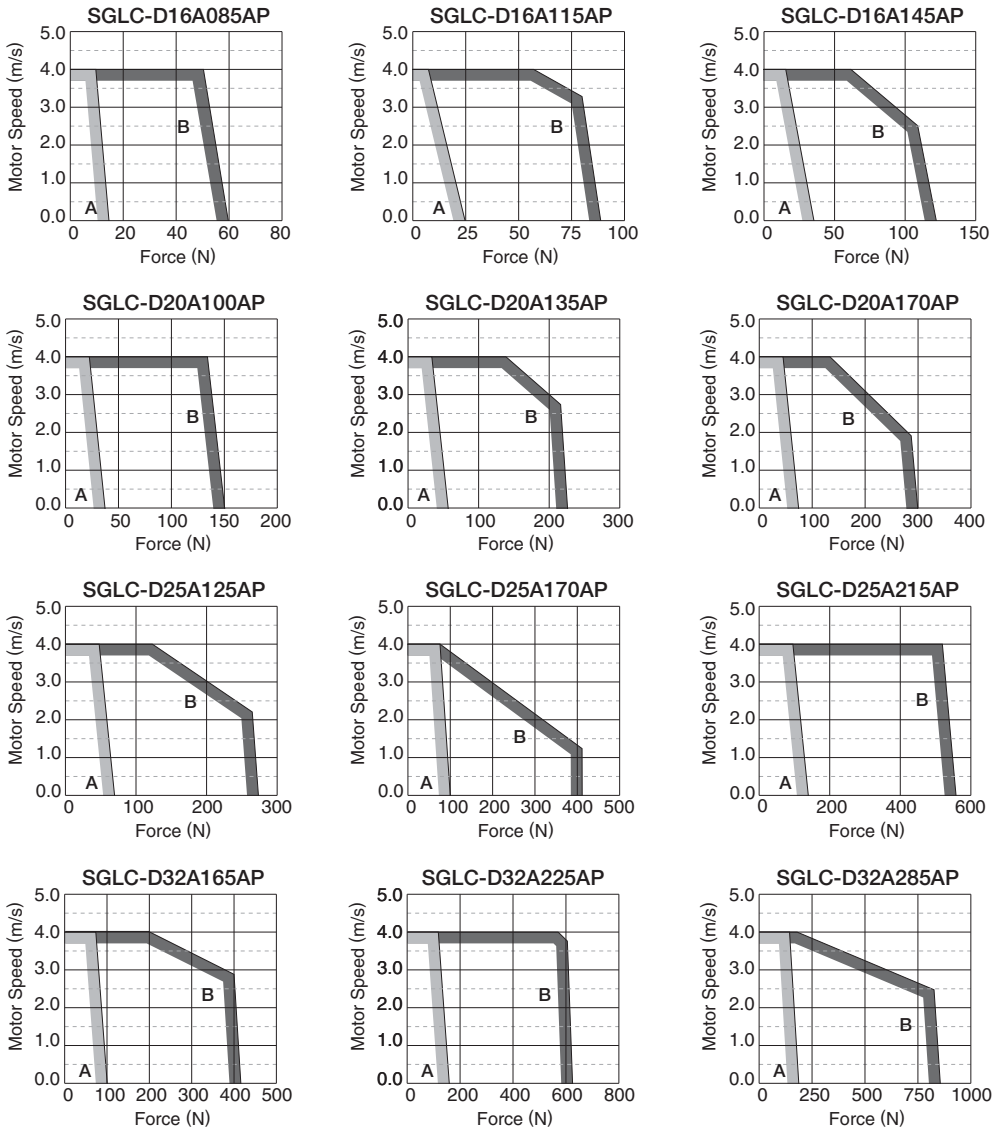

Note: When the effective force during intermittent duty is within the rated force, the servomotor can be used within the intermittent duty zone.

● **Mechanical Specifications of Linear Servomotors**

(1) **Impact Resistance**

- Impact acceleration: 98 m/s²
- Impact occurrences: twice

(2) **Vibration Resistance**

The linear servomotors will withstand the following vibration acceleration in three directions: Vertical, side to side, and front to back.

- Vibration acceleration: Moving Coil : 24.5 m/s²
- Magnetic Way : 24.5 m/s² in axis direction
- 4.9 m/s² in vertically and horizontally

Linear Servomotors

External Dimensions Units: mm

(1) SGLC-D16

- Moving Coil: SGLCW-D16A□□□AP (With a connector by Tyco Electronics AMP K.K.)

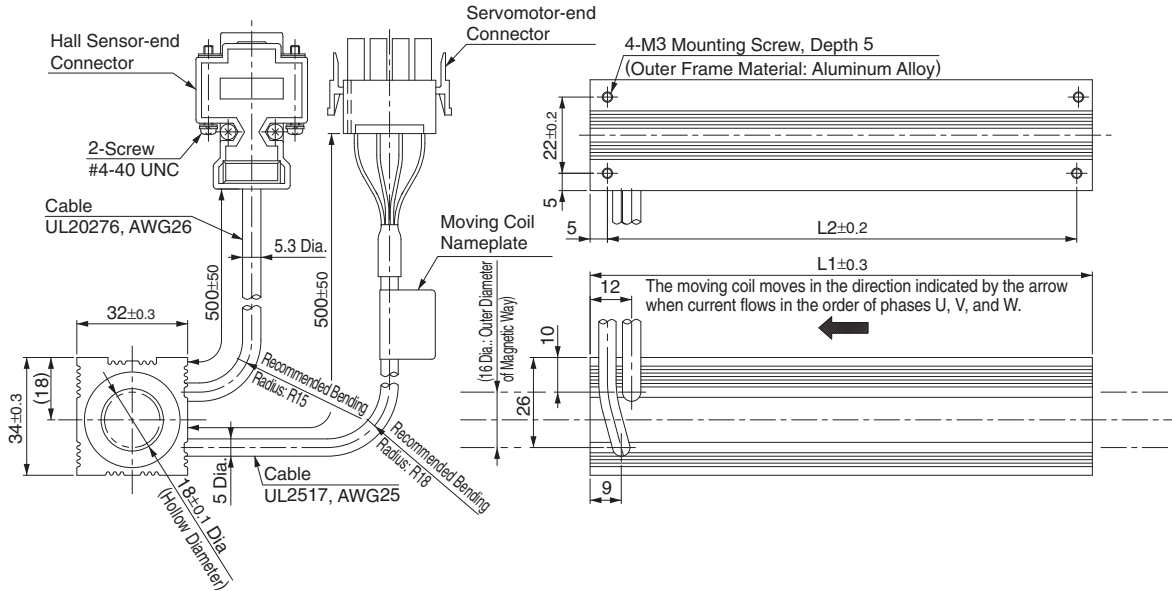

Hall Sensor Connector Specifications

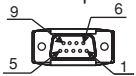

Pin Connector:
17JE-23090-02 (D8C)
by DDK Ltd.

The Mating Connector

Socket Connector:
17JE-13090-02 (D8C)
Stud: 17L-002C or
17L-002C1

Pin No.	Name
1	+5V (Power supply)
2	Phase U
3	Phase V
4	Phase W
5	0V (Power supply)
6	Not used
7	Not used
8	Not used
9	Not used

Linear Servomotor Connector Specifications

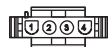

Plug: 350779-1
Pin : 350690-3 or
350561-3 (No.1 to 3)
770210-1 (No.4)

by Tyco
Electronics AMP K.K.
The Mating Connector

Cap: 350780-1
Socket: 350925-1 or
770673-1

Pin No.	Name	Wire Color
1	Phase U	Red
2	Phase V	White
3	Phase W	Blue
4	FG	Green

Moving Coil Model SGLCW-	L1	L2	Approx. Mass* kg
D16A085AP	85	75	0.3
D16A115AP	115	105	0.4
D16A145AP	145	135	0.5

*: The values indicate the mass of moving coil with a hall sensor unit.

Hall Sensor Output Signals

When the moving coil moves in the direction indicated by the arrow in the figure, the relationship between the hall sensor output signals S_u , S_v , S_w and the inverse power of each motor phase V_u , V_v , V_w becomes as shown in the figure below.

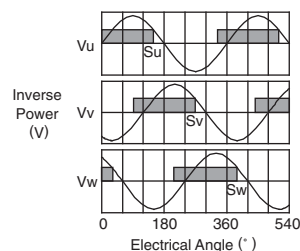

External Dimensions Units: mm

- Magnetic Way: SGLCM-D16□□□A

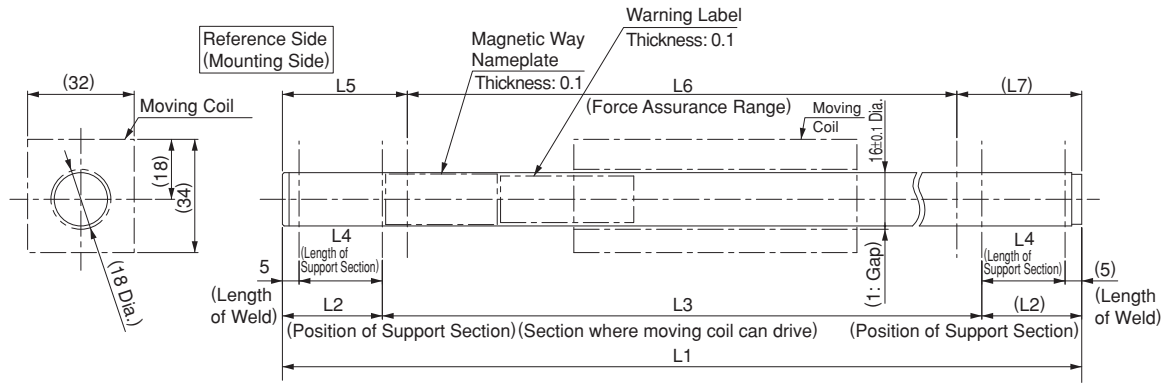

Notes: 1 The magnetic way will become deformed if a magnetic attraction with the moving coil is generated. Take measures over the entire driving range to prevent any interference between the magnetic way and the moving coil after installation.
 2 If you have a pacemaker or any other electronic medical device, do not go near the magnetic way of the linear servomotor.

Magnetic Way Model SGLCM-	L1	L2	L3	L4	L5	L6	L7	Approx. Mass kg	Remarks
D16240A	240±1.6	30	180	25	37.5±0.3	165±1.2	37.5	0.38	-
D16270A	270±1.6	30	210	25	37.5±0.3	195±1.2	37.5	0.43	
D16300A	300±1.6	30	240	25	37.5±0.3	225±1.2	37.5	0.48	Standard
D16330A	330±1.6	30	270	25	37.5±0.3	255±1.2	37.5	0.53	-
D16360A	360±1.6	30	300	25	37.5±0.3	285±1.2	37.5	0.58	
D16390A	390±1.6	30	330	25	37.5±0.3	315±1.2	37.5	0.63	
D16420A	420±1.6	30	360	25	37.5±0.3	345±1.2	37.5	0.68	
D16480A	480±2.5	45	390	40	52.5±0.3	375±2.1	52.5	0.75	
D16510A	510±2.5	45	420	40	52.5±0.3	405±2.1	52.5	0.80	Standard
D16540A	540±2.5	45	450	40	52.5±0.3	435±2.1	52.5	0.85	-
D16570A	570±2.5	45	480	40	52.5±0.3	465±2.1	52.5	0.90	
D16600A	600±2.5	45	510	40	52.5±0.3	495±2.1	52.5	0.95	
D16630A	630±2.5	45	540	40	52.5±0.3	525±2.1	52.5	1.0	
D16660A	660±2.5	45	570	40	52.5±0.3	555±2.1	52.5	1.05	
D16690A	690±2.5	45	600	40	52.5±0.3	585±2.1	52.5	1.1	
D16720A	720±2.5	45	630	40	52.5±0.3	615±2.1	52.5	1.15	
D16750A	750±3	45	660	40	52.5±0.3	645±2.5	52.5	1.2	Standard

Linear Servomotors

External Dimensions Units: mm

(2) SGLC-D20

- Moving Coil: SGLCW-D20A□□□AP (With a connector by Tyco Electronics AMP K.K.)

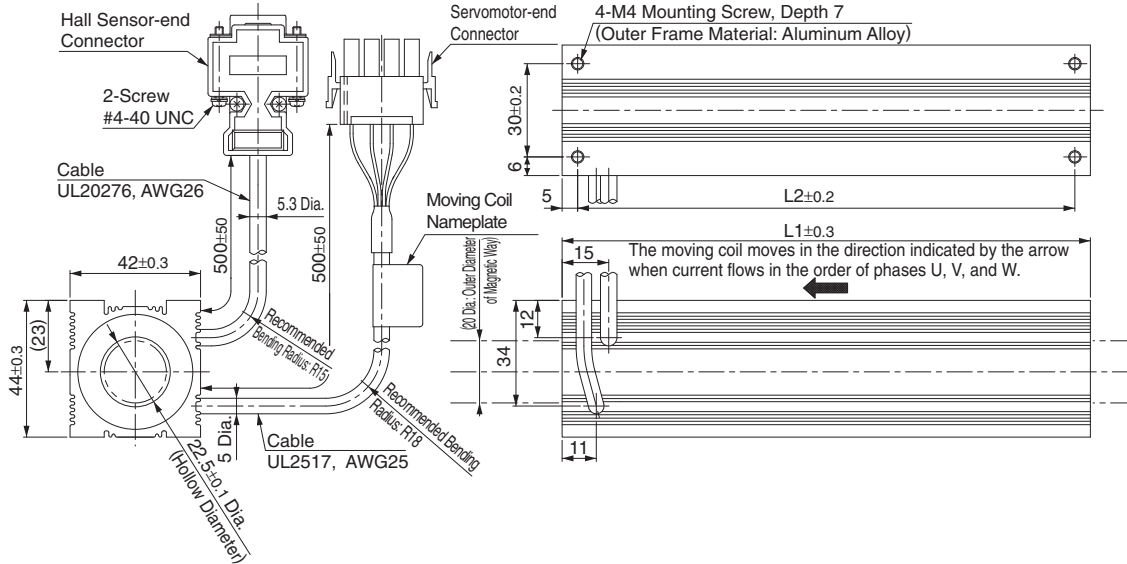

Hall Sensor Connector Specifications



Pin Connector:
17JE-23090-02 (D8C)
by DDK Ltd.

The Mating Connector

Socket Connector:
17JE-13090-02 (D8C)
Stud: 17L-002C or
17L-002C1

Pin No.	Name
1	+5V (Power supply)
2	Phase U
3	Phase V
4	Phase W
5	0V (Power supply)
6	Not used
7	Not used
8	Not used
9	Not used

Linear Servomotor Connector Specifications



Plug: 350779-1
Pin : 350690-3 or
350561-3 (No.1 to 3)
770210-1 (No.4)

by Tyco
Electronics AMP K.K.
The Mating Connector

Cap: 350780-1
Socket: 350925-1 or
770673-1

Pin No.	Name	Wire Color
1	Phase U	Red
2	Phase V	White
3	Phase W	Blue
4	FG	Green

Moving Coil Model SGLCW-	L1	L2	Approx. Mass* kg
D20A100AP	100	90	0.6
D20A135AP	135	125	0.8
D20A170AP	170	160	1.0

*: The values indicate the mass of moving coil with a hall sensor unit.

Hall Sensor Output Signals

When the moving coil moves in the direction indicated by the arrow in the figure, the relationship between the hall sensor output signals S_u , S_v , S_w and the inverse power of each motor phase V_u , V_v , V_w becomes as shown in the figure below.

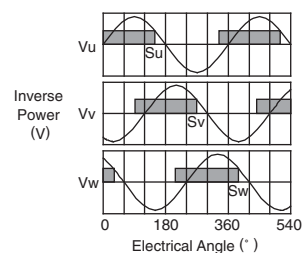

External Dimensions Units: mm

- Magnetic Way: SGLCM-D20□□□A

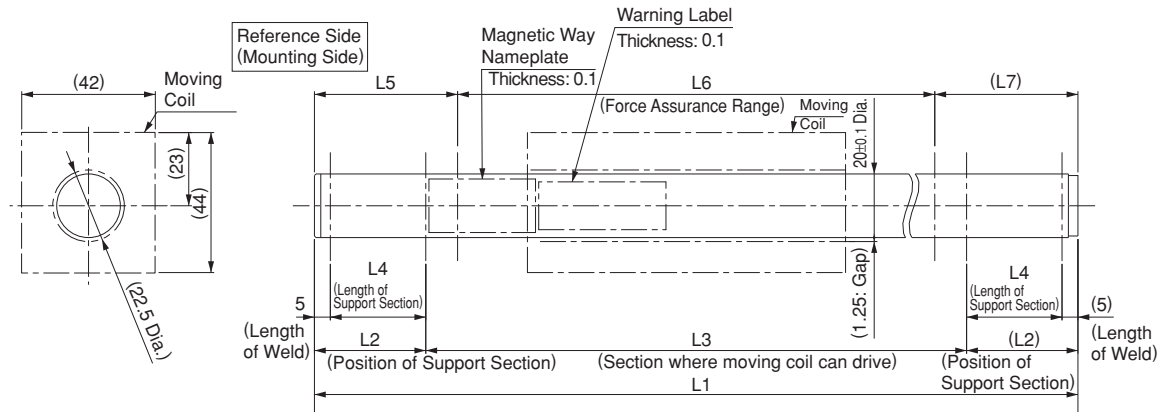

- Notes: 1 The magnetic way will become deformed if a magnetic attraction with the moving coil is generated.
 Take measures over the entire driving range to prevent any interference between the magnetic way and the moving coil after installation.
 2 If you have a pacemaker or any other electronic medical device, do not go near the magnetic way of the linear servomotor.

Magnetic Way Model SGLCM-	L1	L2	L3	L4	L5	L6	L7	Approx. Mass kg	Remarks
D20280A	280±1.6	35	210	30	45±0.3	190±1.2	45	0.68	-
D20315A	315±1.6	35	245	30	45±0.3	225±1.2	45	0.77	-
D20350A	350±1.6	35	280	30	45±0.3	260±1.2	45	0.86	Standard
D20385A	385±1.6	35	315	30	45±0.3	295±1.2	45	0.95	-
D20420A	420±1.6	35	350	30	45±0.3	330±1.2	45	1.0	-
D20455A	455±1.6	35	385	30	45±0.3	365±1.2	45	1.1	-
D20490A	490±1.6	35	420	30	45±0.3	400±1.2	45	1.2	-
D20555A	555±2.5	50	455	45	60±0.3	435±2.1	60	1.35	-
D20590A	590±2.5	50	490	45	60±0.3	470±2.1	60	1.45	Standard
D20625A	625±2.5	50	525	45	60±0.3	505±2.1	60	1.55	-
D20660A	660±2.5	50	560	45	60±0.3	540±2.1	60	1.6	-
D20695A	695±2.5	50	595	45	60±0.3	575±2.1	60	1.7	-
D20730A	730±2.5	50	630	45	60±0.3	610±2.1	60	1.8	-
D20765A	765±2.5	50	665	45	60±0.3	645±2.1	60	1.9	-
D20800A	800±2.5	50	700	45	60±0.3	680±2.1	60	2.0	-
D20835A	835±2.5	50	735	45	60±0.3	715±2.1	60	2.1	-
D20870A	870±3	50	770	45	60±0.3	750±2.5	60	2.2	Standard

External Dimensions Units: mm

(3) SGLC-D25

- Moving Coil: SGLCW-D25A□□□AP (With a connector by Tyco Electronics AMP K.K.)

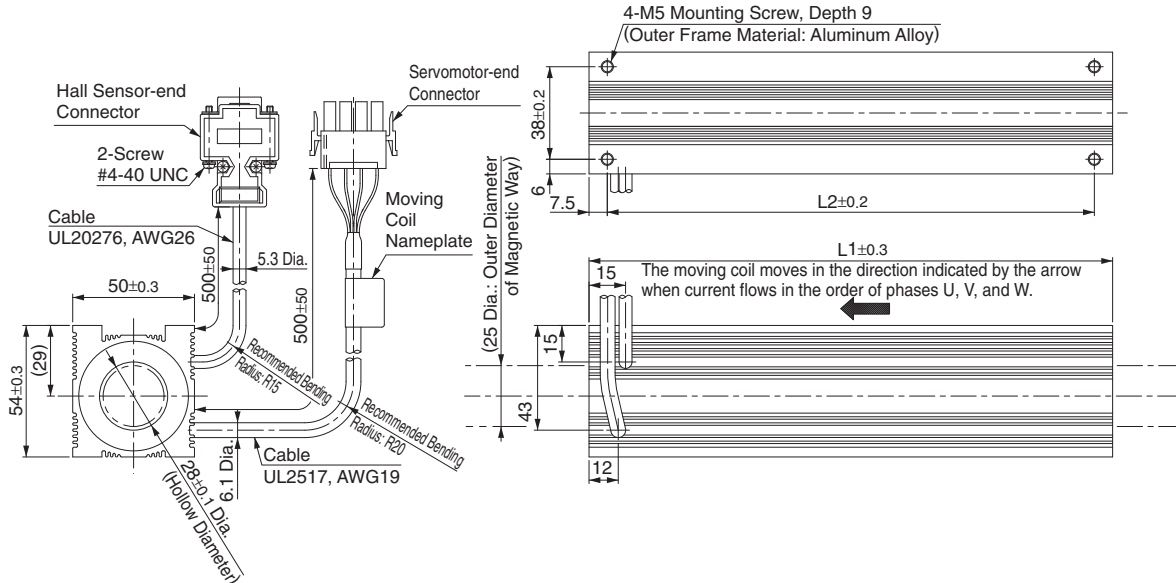

Hall Sensor Connector Specifications

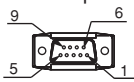

Pin Connector:
17JE-23090-02 (D8C)
by DDK Ltd.

The Mating Connector

Socket connector:
17JE-13090-02 (D8C)
Stud: 17L-002C or
17L-002C1

Pin No.	Name
1	+5V (Power supply)
2	Phase U
3	Phase V
4	Phase W
5	0V (Power supply)
6	Not used
7	Not used
8	Not used
9	Not used

Linear Servomotor Connector Specifications



Plug: 350779-1
Pin: (No. 1 to 3)
350561-3 or 350690-3
(No. 4)
350654-1 or 350669-1
by Tyco Electronics AMP K.K.

The Mating Connector

Cap : 350780-1
Socket: 350925-1 or
770673-1

Pin No.	Name	Wire Color
1	Phase U	Red
2	Phase V	White
3	Phase W	Blue
4	FG	Green

Moving Coil Model SGLCW-	L1	L2	Approx. Mass* kg
D25A125AP	125	110	1.0
D25A170AP	170	153	1.4
D25A215AP	215	200	1.8

*: The values indicate the mass of moving coil with a hall sensor unit.

Hall Sensor Output Signals

When the moving coil moves in the direction indicated by the arrow in the figure, the relationship between the hall sensor output signals S_u , S_v , S_w and the inverse power of each motor phase V_u , V_v , V_w becomes as shown in the figure below.

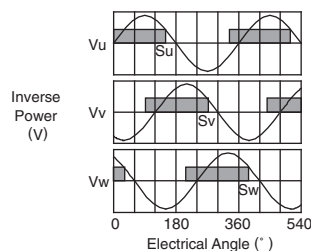

External Dimensions Units: mm

- Magnetic Way: SGLCM-D25□□□A

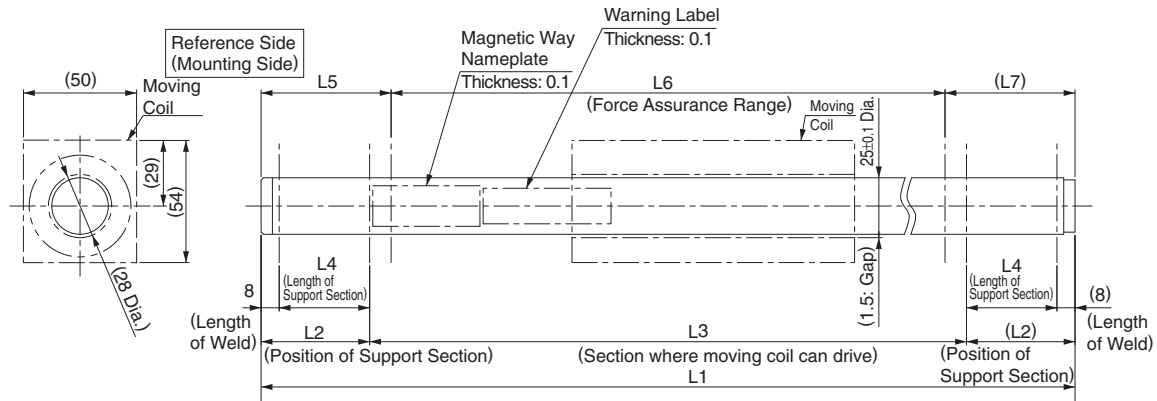

- Notes: 1 The magnetic way will become deformed if a magnetic attraction with the moving coil is generated. Take measures over the entire driving range to prevent any interference between the magnetic way and the moving coil after installation.
 2 If you have a pacemaker or any other electronic medical device, do not go near the magnetic way of the linear servomotor.

Magnetic Way Model SGLCM-	L1	L2	L3	L4	L5	L6	L7	Approx. Mass kg	Remarks
D25360A	360±1.6	45	270	37	57.5±0.3	245±1.2	57.5	1.5	-
D25405A	405±1.6	45	315	37	57.5±0.3	290±1.2	57.5	1.65	
D25450A	450±1.6	45	360	37	57.5±0.3	335±1.2	57.5	1.8	Standard
D25495A	495±1.6	45	405	37	57.5±0.3	380±1.2	57.5	1.95	-
D25540A	540±1.6	45	450	37	57.5±0.3	425±1.2	57.5	2.1	
D25585A	585±1.6	45	495	37	57.5±0.3	470±1.2	57.5	2.25	
D25630A	630±1.6	45	540	37	57.5±0.3	515±1.2	57.5	2.4	
D25705A	705±2.5	60	585	52	72.5±0.3	560±2.1	72.5	2.85	
D25750A	750±2.5	60	630	52	72.5±0.3	605±2.1	72.5	3.0	Standard
D25795A	795±2.5	60	675	52	72.5±0.3	650±2.1	72.5	3.15	-
D25840A	840±2.5	60	720	52	72.5±0.3	695±2.1	72.5	3.3	
D25885A	885±2.5	60	765	52	72.5±0.3	740±2.1	72.5	3.45	
D25930A	930±2.5	60	810	52	72.5±0.3	785±2.1	72.5	3.6	
D25975A	975±2.5	60	855	52	72.5±0.3	830±2.1	72.5	3.75	
D251020A	1020±2.5	60	900	52	72.5±0.3	875±2.1	72.5	3.9	
D251065A	1065±2.5	60	945	52	72.5±0.3	920±2.1	72.5	4.05	
D251110A	1110±3	60	990	52	72.5±0.3	965±2.5	72.5	4.2	Standard

External Dimensions Units: mm

(4) SGLC-D32

- Moving Coil: SGLCW-D32A□□□AP (With a connector by Tyco Electronics AMP K.K.)

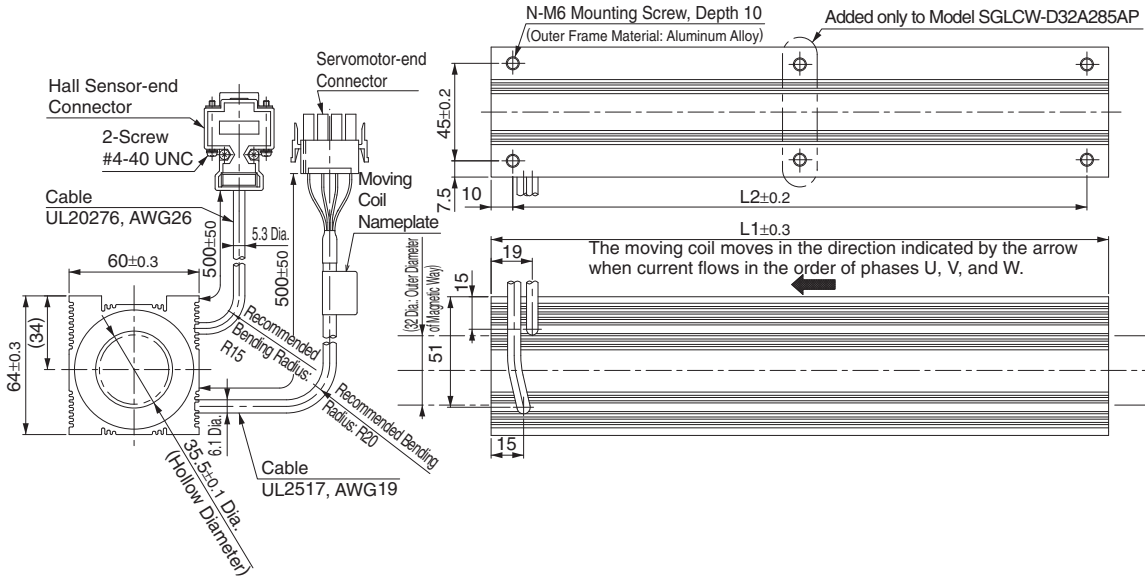

Hall Sensor Connector Specifications

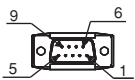

Pin Connector:
17JE-23090-02 (D8C)
by DDK Ltd.

The Mating Connector

Socket connector:
17JE-13090-02 (D8C)
Stud: 17L-002C or
17L-002C1

Pin No.	Name
1	+5V (Power supply)
2	Phase U
3	Phase V
4	Phase W
5	0V (Power supply)
6	Not used
7	Not used
8	Not used
9	Not used

Linear Servomotor Connector Specifications

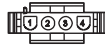

Plug: 350779-1
Pin: (No. 1 to 3)
350561-3 or 350690-3
(No. 4)
350654-1 or 350669-1
by Tyco Electronics AMP K.K.

The Mating Connector

Cap: 350780-1
Socket: 350925-1 or
770673-1

Pin No.	Name	Wire Color
1	Phase U	Red
2	Phase V	White
3	Phase W	Blue
4	FG	Green

Moving Coil Model SGLCW-	L1	L2	N	Approx. Mass* kg
D32A165AP	165	145	4	1.8
D32A225AP	225	205	4	2.5
D32A285AP	285	265	6	3.2

*: The values indicate the mass of moving coil with a hall sensor unit.

Hall Sensor Output Signals

When the moving coil moves in the direction indicated by the arrow in the figure, the relationship between the hall sensor output signals S_u , S_v , S_w and the inverse power of each motor phase V_u , V_v , V_w becomes as shown in the figure below.

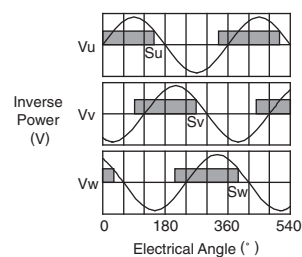

External Dimensions Units: mm

- Magnetic Way: SGLCM-D32□□□A

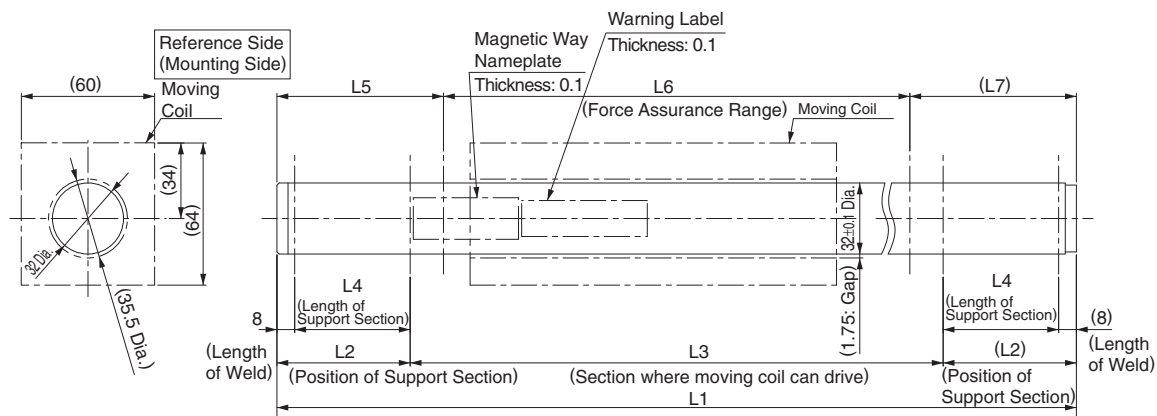

Notes: 1 The magnetic way will become deformed if a magnetic attraction with the moving coil is generated.
 Take measures over the entire driving range to prevent any interference between the magnetic way and the moving coil after installation.
 2 If you have a pacemaker or any other electronic medical device, do not go near the magnetic way of the linear servomotor.

Magnetic Way Model SGLCM-	L1	L2	L3	L4	L5	L6	L7	Approx. Mass kg	Remarks
D32480A	480±1.6	60	360	52	75±0.3	330±1.2	75	3.0	-
D32540A	540±1.6	60	420	52	75±0.3	390±1.2	75	3.4	-
D32600A	600±1.6	60	480	52	75±0.3	450±1.2	75	3.8	Standard
D32660A	660±1.6	60	540	52	75±0.3	510±1.2	75	4.2	-
D32720A	720±1.6	60	600	52	75±0.3	570±1.2	75	4.6	-
D32780A	780±1.6	60	660	52	75±0.3	630±1.2	75	5.0	-
D32840A	840±1.6	60	720	52	75±0.3	690±1.2	75	5.4	-
D32960A	960±2.5	90	780	82	105±0.3	750±2.1	105	5.9	-
D321020A	1020±2.5	90	840	82	105±0.3	810±2.1	105	6.3	Standard
D321080A	1080±2.5	90	900	82	105±0.3	870±2.1	105	6.7	-
D321140A	1140±2.5	90	960	82	105±0.3	930±2.1	105	7.1	-
D321200A	1200±2.5	90	1020	82	105±0.3	990±2.1	105	7.5	-
D321260A	1260±2.5	90	1080	82	105±0.3	1050±2.1	105	7.9	-
D321320A	1320±2.5	90	1140	82	105±0.3	1110±2.1	105	8.3	-
D321380A	1380±2.5	90	1200	82	105±0.3	1170±2.1	105	8.7	-
D321440A	1440±2.5	90	1260	82	105±0.3	1230±2.1	105	9.1	-
D321500A	1500±3	90	1320	82	105±0.3	1290±2.5	105	9.5	Standard

Selecting Cables

●Cables Connections

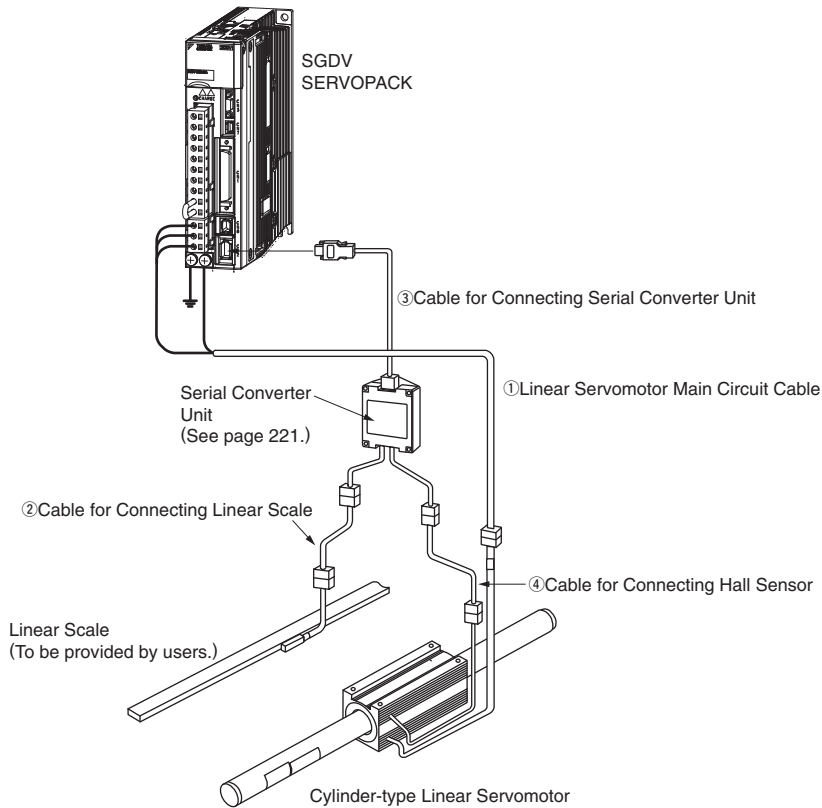

●Cables

Name	Applicable Linear Servomotor Model	Length	Order No.	Specifications	Details
① Linear Servomotor Main Circuit Cables	All models	1 m	JZSP-CLN11-01-E	SERVOPACK End Linear Servomotor End	(1)
		3 m	JZSP-CLN11-03-E		
		5 m	JZSP-CLN11-05-E		
		10 m	JZSP-CLN11-10-E		
		15 m	JZSP-CLN11-15-E		
② Cables for Connecting Linear Scales*	All models	1 m	JZSP-CLL00-01-E	Serial Converter Unit End Linear Scale End	(2)
		3 m	JZSP-CLL00-03-E		
		5 m	JZSP-CLL00-05-E		
		10 m	JZSP-CLL00-10-E		
		15 m	JZSP-CLL00-15-E		
③ Cables for Connecting Serial Converter Units	All models	1 m	JZSP-CLP70-01-E	SERVOPACK End Serial Converter Unit End	(3)
		3 m	JZSP-CLP70-03-E		
		5 m	JZSP-CLP70-05-E		
		10 m	JZSP-CLP70-10-E		
		15 m	JZSP-CLP70-15-E		
④ Cables for Connecting Hall Sensors	All models	1 m	JZSP-CLL10-01-E	Serial Converter Unit End Hall Sensor Unit End	(4)
		3 m	JZSP-CLL10-03-E		
		5 m	JZSP-CLL10-05-E		
		10 m	JZSP-CLL10-10-E		
		15 m	JZSP-CLL10-15-E		

*: When using serial converter unit JZDP-G00□-□□□-E, the maximum cable length should be 3 m.

Selecting Cables

(1) Linear Servomotor Main Circuit Cables: JZSP-CLN11-□□-E

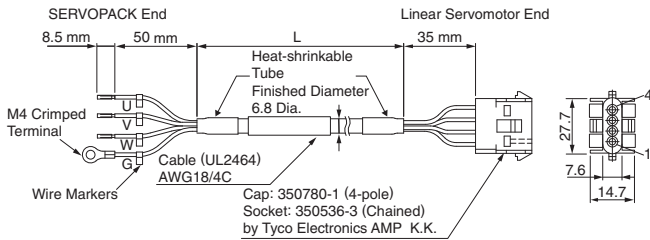

• Wiring Specifications

SERVOPACK-end Leads		Linear Servomotor-end Connector	
Wire Color	Signal	Signal	Pin. No.
Red	Phase U	Phase U	1
White	Phase V	Phase V	2
Blue	Phase W	Phase W	3
Green/yellow	FG	FG	4

(2) Cables for Connecting Linear Scales: JZSP-CLL00-□□-E

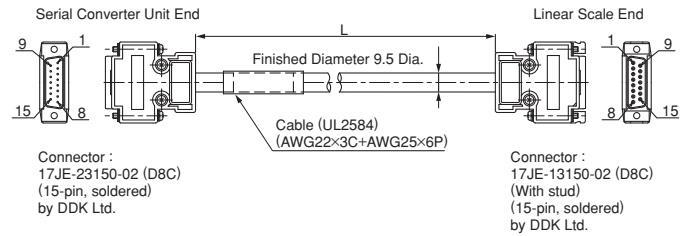

• Wiring Specifications

Serial Converter Unit End			Linear Scale End		
Pin No.	Signal		Pin No.	Signal	
1	/Cos(V1-)		1	/Cos(V1-)	
2	/Sin(V2-)		2	/Sin(V2-)	
3	Ref(V0+)		3	Ref(V0+)	
4	+5V		4	+5V	
5	5Vs		5	5Vs	
6	BID		6	BID	
7	Vx		7	Vx	
8	Vq		8	Vq	
9	Cos(V1+)		9	Cos(V1+)	
10	Sin(V2+)		10	Sin(V2+)	
11	/Ref(V0+)		11	/Ref(V0-)	
12	0V		12	0V	
13	0Vs		13	0Vs	
14	DIR		14	DIR	
15	Inner		15	Inner	
Case	Shield		Case	Shield	

(3) Cables for Connecting Serial Converter Units: JZSP-CLP70-□□-E

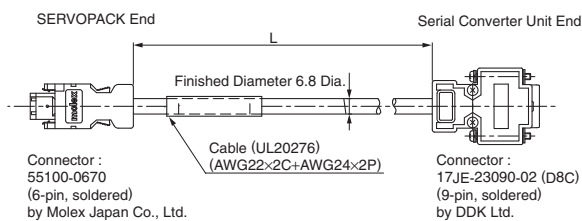

• Wiring Specifications

SERVOPACK End			Serial Converter Unit End		
Pin No.	Signal	Wire Color	Pin No.	Signal	Wire Color
1	PG5V	Red	1	+5V	Red
2	PG0V	Black	5	0V	Black
3	-	-	3	-	-
4	-	-	4	-	-
5	PS	Light blue	2	Phase S output	Light blue
6	/PS	Light blue/white	6	Phase /S output	Light blue/white
Shell	Shield	-	Case	Shield	-
			7	-	-
			8	-	-
			9	-	-

(4) Cables for Connecting Hall Sensors JZSP-CLL10-□□-E

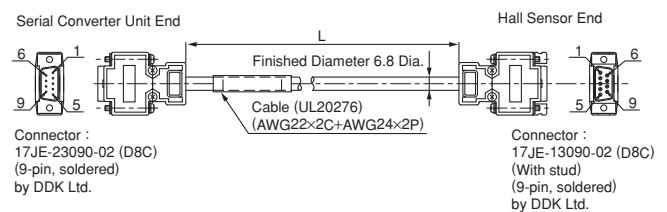

• Wiring Specifications

Serial Converter Unit End			Hall Sensor End		
Pin No.	Signal		Pin No.	Signal	
1	+5V		1	+5V	
2	Phase U input		2	Phase U input	
3	Phase V input		3	Phase V input	
4	Phase W input		4	Phase W input	
5	0V		5	0V	
6	-		6	-	
7	-		7	-	
8	-		8	-	
9	-		9	-	
Case	Shield		Case	Shield	



Linear Servomotor General Instructions

Serial Converter Unit (Model: JZDP-□00□-□□□-E)

● Characteristics and Specifications

Items		JZDP-D00□-□□□-E	JZDP-G00□-□□□-E
Electrical Characteristics	Power Supply Voltage	+5.0 V±5%, ripple content 5% max.	
	Current Consumption*1	120 mA Typ. 350 mA max.	
	Signal Resolution	Input two-phase sine wave: 1/256 pitch	Input two-phase sine wave: 1/4096 pitch
	Max. Response Frequency	250 kHz	100 kHz
	Analog Input Signals*2 (cos, sin, Ref)	Differential input amplitude: 0.4 to 1.2 V Input signal level: 1.5 to 3.5 V	
	Hall Sensor Input Signal	CMOS level	
	Output Signals*3	Position data, hall sensor information, and alarms	
	Output Method	Serial data transmission	
	Output Circuit	Balanced transceiver (SN75LBC176 or the equivalent) Internal terminal resistance: 120 Ω	
Mechanical Characteristics	Approx. Mass	150 g	
	Vibration Resistance	98 m/s ² max. (10 to 2500 Hz) in three directions	
	Impact Resistance	980 m/s ² , (11 ms) two times in three directions	
Environmental Conditions	Ambient Temperature	0 to 55°C	
	Storage Temperature	-20 to +80°C	
	Humidity	20% to 90% RH (no condensation)	

*1: The current consumption of the linear scale and hall sensor is not included in this value.

The current consumption of linear scale and hall sensor must be taken into consideration for the current capacity of host controller that supplies the power. The current consumption of hall sensor: Approx. 40 mA.

*2: Input a value within the specified range. Otherwise, incorrect position information is output, and the device may be damaged.

*3: The power is turned on, and the transmission is enabled after 100 ms to 300 ms.

Serial Converter Unit (Model: JZDP-□00□-□□□-E)

● Model Designations

JZDP - □00□ - □□□ - E

Serial Converter Unit Model			
Code	Appearance	Applicable Linear Scale	Hall Sensor
D003 G003		Manufactured by HEIDENHAIN Corp.	None
D005 G005		Manufactured by RENISHAW plc.	None
D006 G006		Manufactured by HEIDENHAIN Corp.	Provided
D008 G008		Manufactured by RENISHAW plc.	Provided

Applicable Linear Servomotor					
Servomotor Model		Symbol	Servomotor Model		Symbol
SGLGW- (Coreless)	30A050C	250	SGLTW- (Iron core, T-type)	20A170A	011
	30A080C	251		20A320A	012
	40A140C	252		20A460A	013
	40A253C	253		35A170A	014
	40A365C	254		35A320A	015
	60A140C	258		35A460A	016
	60A253C	259		35A170H	105
	60A365C	260		35A320H	106
	90A200C	264		50A170H	108
	90A370C	265		50A320H	109
SGLGW- + SGLGM- □-M (Coreless)	40A140C	255	40A400B	185	
	40A253C	256	40A600B	186	
	40A365C	257	80A400B	187	
	60A140C	261	80A600B	188	
	60A253C	262	35D170H	193	
	60A365C	263	35D320H	194	
	20A090A	017	50D170H	195	
	20A120A	018	50D320H	196	
	35A120A	019	40D400B	197	
	35A230A	020	40D600B	198	
SGLFW- (Iron core, F-type)	50A200B	181	80D400B	199	
	50A380B	182	80D600B	200	
	1ZA200B	183	D16A085AP	354	
	1ZA380B	184	D16A115AP	373	
	35D120A	211	D16A145AP	356	
	35D230A	212	D20A100AP	357	
	50D200B	189	D20A135AP	358	
	50D380B	190	D20A170AP	359	
	1ZD200B	191	D25A125AP	360	
	1ZD380B	192	D25A170AP	374	
SGLC-			D25A215AP	362	
			D32A165AP	363	
			D32A225AP	364	
			D32A285AP	365	

When a standard-force magnetic way is used.

When a high-force magnetic way is used

Linear Servomotor General Instructions

Serial Converter Unit (Model: JZDP-□00□-□□□-E)

● Analog Signal Input Timing

The following figure shows the input timing of the analog signals.

When the cos and sin signals are shifted 180 degrees, the differential signals are the /cos and /sin signals.

The specifications of the cos, /cos, sin, and /sin signals are identical except for the phase.

Input the signals Ref and /Ref so that they shall cross each other as shown in the figure because they are input into the converter. When they are crossed, the output data will be counted up.

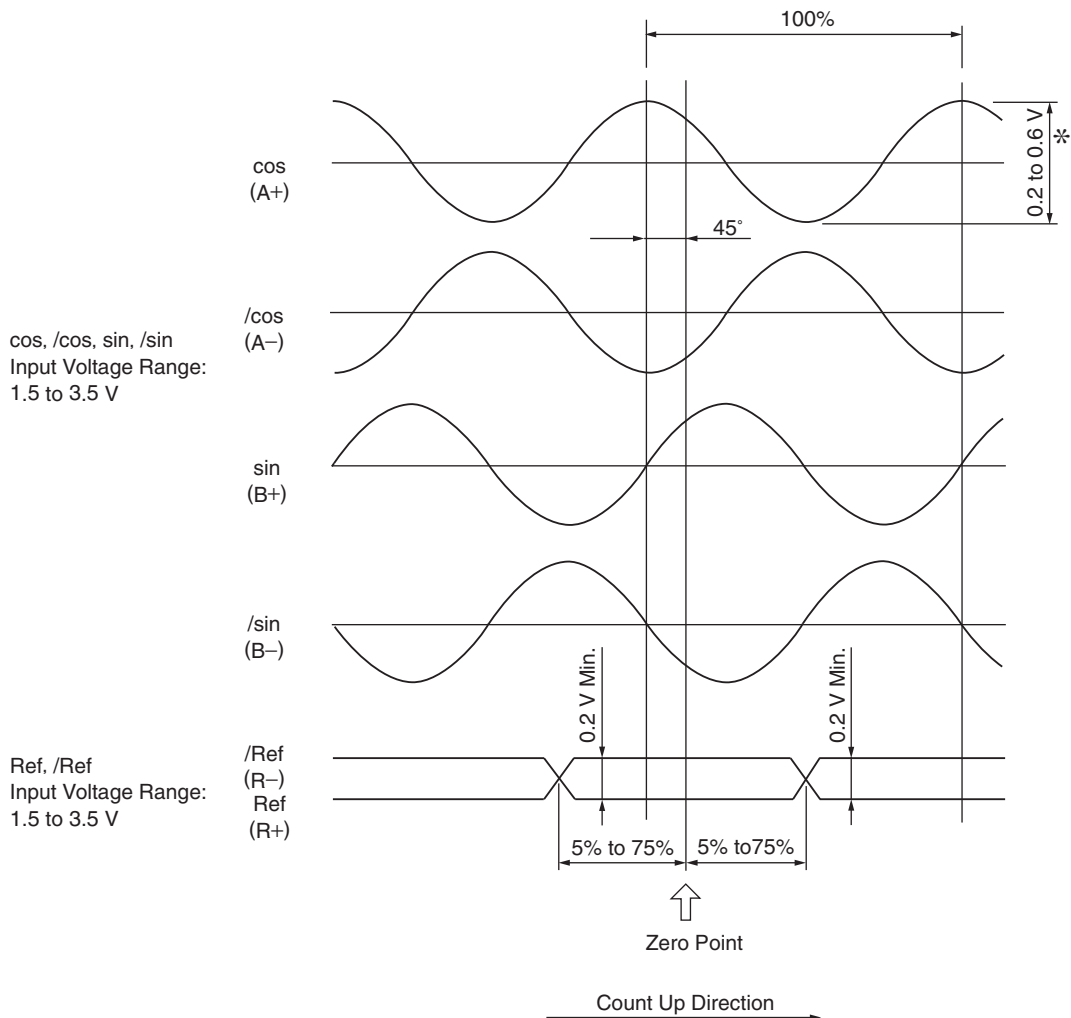

*:If the analog signal amplitude declines to about 0.35 V because of differential amplitude, the serial converter outputs an alarm.

IMPORTANT

■ Precautions

- 1 Never perform insulation resistance and withstand voltage tests.
- 2 When analog signals are input to the serial converter unit, noise influence on the analog signals affects the unit's ability to output correct position information. The analog cable must be as short as possible and shielded.
- 3 Use the serial converter unit without gases such as H₂S.
- 4 Do not connect or disconnect the unit while power is being supplied, or the unit may be damaged.
- 5 When using multiple axes, use a shield cable for each axis. Do not use a shield cable for multiple axes.

Serial Converter Unit (Model: JZDP-□00□-□□□-E) Units: mm

● **Without Cable for Hall Sensor (For Linear Scale by HEIDENHAIN Corporation)**

Serial Converter Unit Model: JZDP-□003-□□□-E

(1) Connection Example

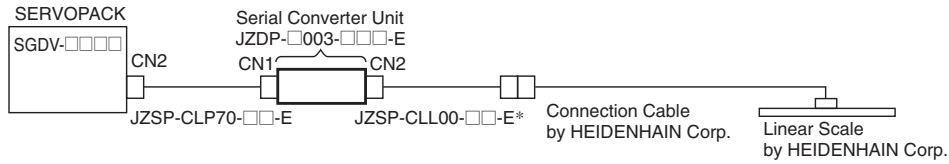

*: When using serial converter unit JZDP-G00□-□□□-E, the maximum cable length should be 3 m.

(2) External Dimensions

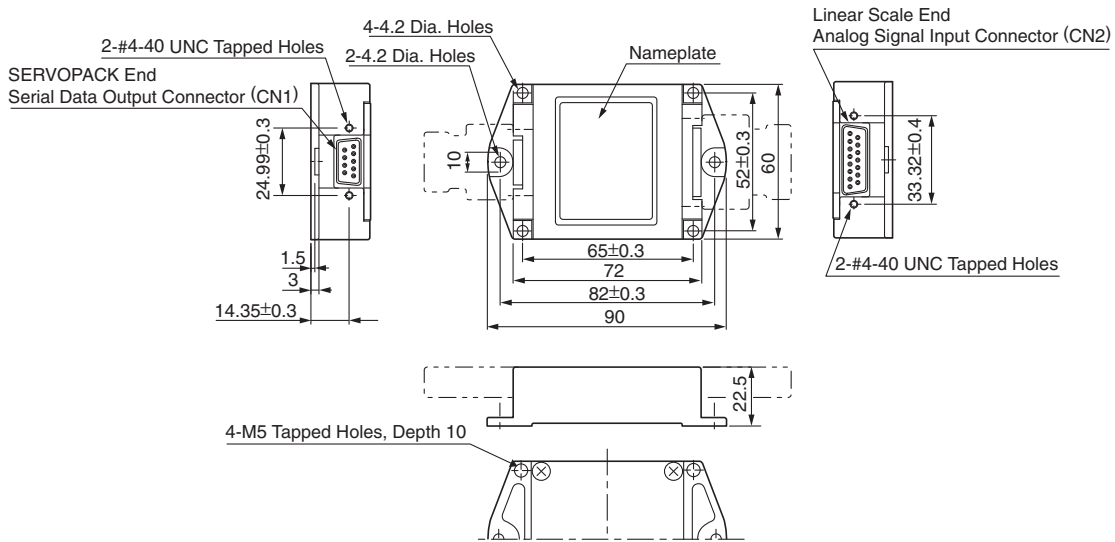

Pin No.	Signal
1	+5V
2	Phase S output
3	Not used
4	Not used
5	0V
6	Phase /S output
7	Not used
8	Not used
9	Not used
Case	Shield

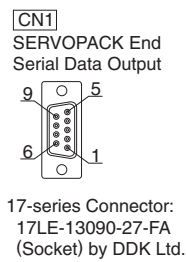

Pin No.	Signal
1	cos input (A+)
2	0V
3	sin input (B+)
4	+5V
5	Not used
6	Not used
7	/Ref input (R-)
8	Not used
9	/cos input (A-)
10	0V sensor
11	/sin input (B-)
12	5V sensor
13	Not used
14	Ref input (R+)
15	Not used
Case	Shield

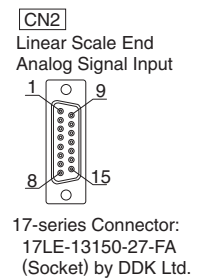

- Notes: 1 Do not use the unused pins.
 2 Contact HEIDENHAIN Corporation for details of connection cables (analog 1 Vp-p output, D-sub 15-pin, male) by HEIDENHAIN Corporation.
 3 Use the same terminal for 5-V sensor and phase-W input.
 4 Phase U, V, and W input are internally pulled up at 10 kΩ.

Serial Converter Unit (Model: JZDP-□00□-□□□-E) Units: mm

● Without Cable for Hall Sensor (For Linear Scale by Renishaw plc.)

Serial Converter Unit Model: JZDP-□005-□□□-E

(1) Connection Example

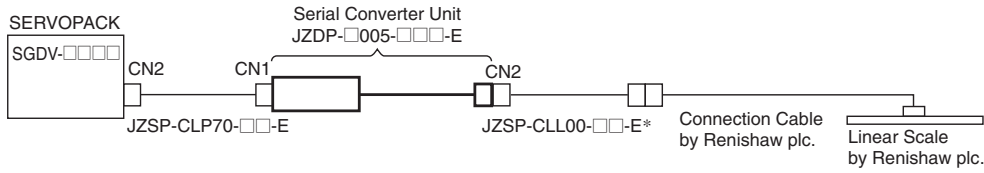

*: When using serial converter unit JZDP-G00□-□□□-E, the maximum cable length should be 3 m.

(2) External Dimensions

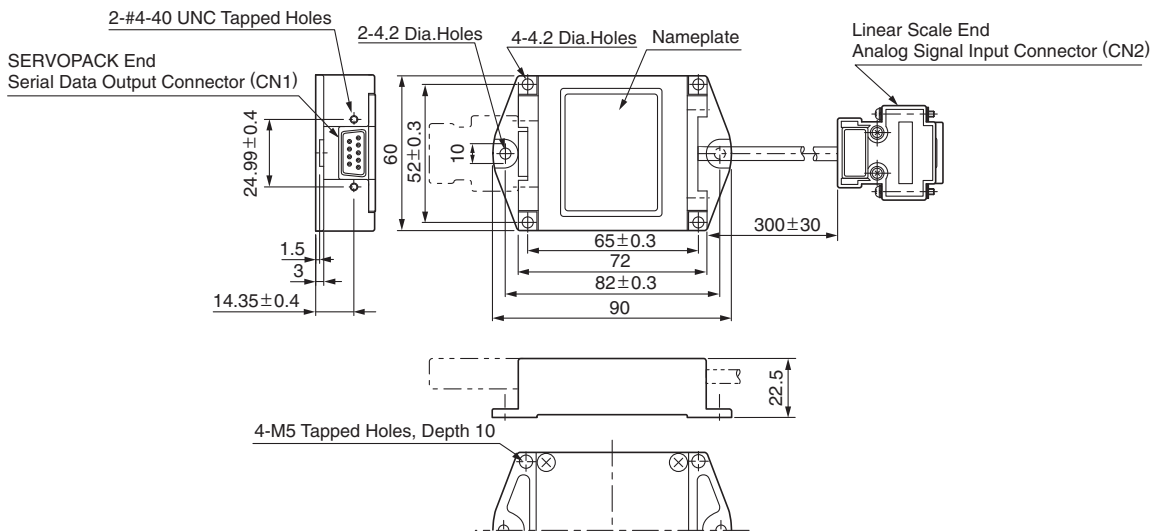

Pin No.	Signal
1	+5V
2	Phase S output
3	Not used
4	Not used
5	0V
6	Phase /S output
7	Not used
8	Not used
9	Not used
Case	Shield

SERVOPACK does not have the function to process Vq signals.

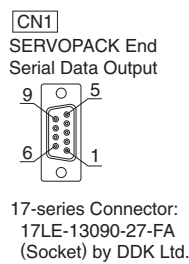

Pin No.	Signal
1	cos input (V1-)
2	sin input (V2-)
3	Ref input (V0+)
4	+5V
5	5Vs
6	Not used
7	Not used
8	Not used
9	cos input (V1+)
10	sin input (V2+)
11	/Ref input (V0-)
12	0V
13	0Vs
14	Not used
15	inner (0V)
Case	Shield

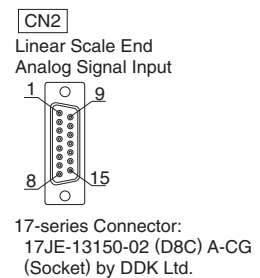

- Notes: 1 Do not use the unused pins.
2 Contact Renishaw plc. for details of connection cables (analog 1 Vp-p output, D-sub 15-pin, male) by Renishaw plc. However, the BID and DIR signals are not connected.
3 Use the linear scale-end connector to change the zero point specifications of the linear scale.

Serial Converter Unit (Model: JZDP-□00□-□□□-E) Units: mm

● **With Cable for Hall Sensor (For Linear Scale by HEIDENHAIN Corporation)**

Serial Converter Unit Model: JZDP-□006-□□□-E

(1) Connection Example

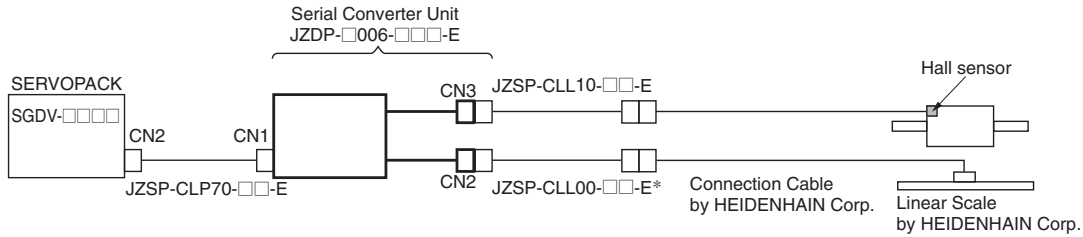

*: When using serial converter unit JZDP-G00□-□□□-E, the maximum cable length should be 3 m.

(2) External Dimensions

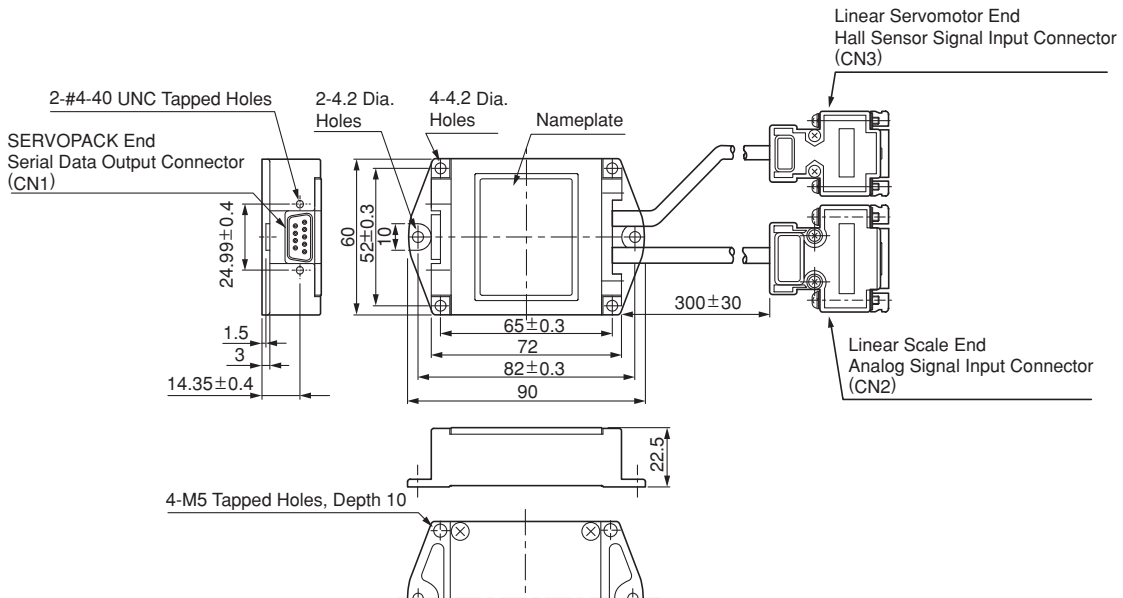

CN1
SERVOPACK End
Serial Data Output

17-series Connector:
17LE-13090-27-FA
(Socket) by DDK Ltd.

CN2
Linear Scale End
Analog Signal Input

17-series Connector:
17JE-13150-02 (D8C) A-CG
(Socket) by DDK Ltd.

CN3
Linear Servomotor End
Hall Sensor Signal Input

17-series Connector:
17JE-13090-02 (D8C) A-CG
by DDK Ltd.

Pin No.	Signal
1	+5V
2	Phase S output
3	Not used
4	Not used
5	0V
6	Phase /S output
7	Not used
8	Not used
9	Not used
Case	Shield

Pin No.	Signal
1	cos input (A+)
2	0V
3	sin input (B+)
4	+5V
5	Not used
6	Not used
7	/Ref input (R-)
8	Not used
9	/cos input (A-)
10	0V sensor
11	/sin input (B-)
12	5V sensor
13	Not used
14	Ref input (R+)
15	Not used
Case	Shield

Pin No.	Signal
1	+5V
2	Phase U input
3	Phase V input
4	Phase W input
5	0V
6	Not used
7	Not used
8	Not used
9	Not used
Case	Shield

Notes: 1 Do not use the unused pins.
2 Contact HEIDENHAIN Corporation for details of connection cables (analog 1 Vp-p output, D-sub 15-pin, male) by HEIDENHAIN Corporation.
3 Phase U, V, and W input are internally pulled up at 10 kΩ.

Serial Converter Unit (Model: JZDP-□00□-□□□-E) Units: mm

● With Cable for Hall Sensor (For Linear Scale by Renishaw plc.)

Serial Converter Unit Model: JZDP-□008-□□□-E

(1) Connection Example

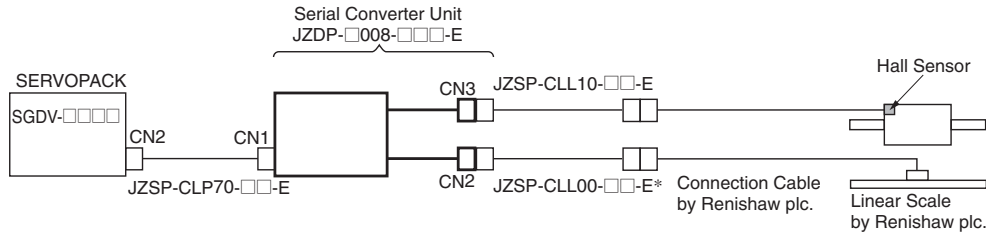

*: When using serial converter unit JZDP-G00□-□□□-E, the maximum cable length should be 3 m.

(2) External Dimensions

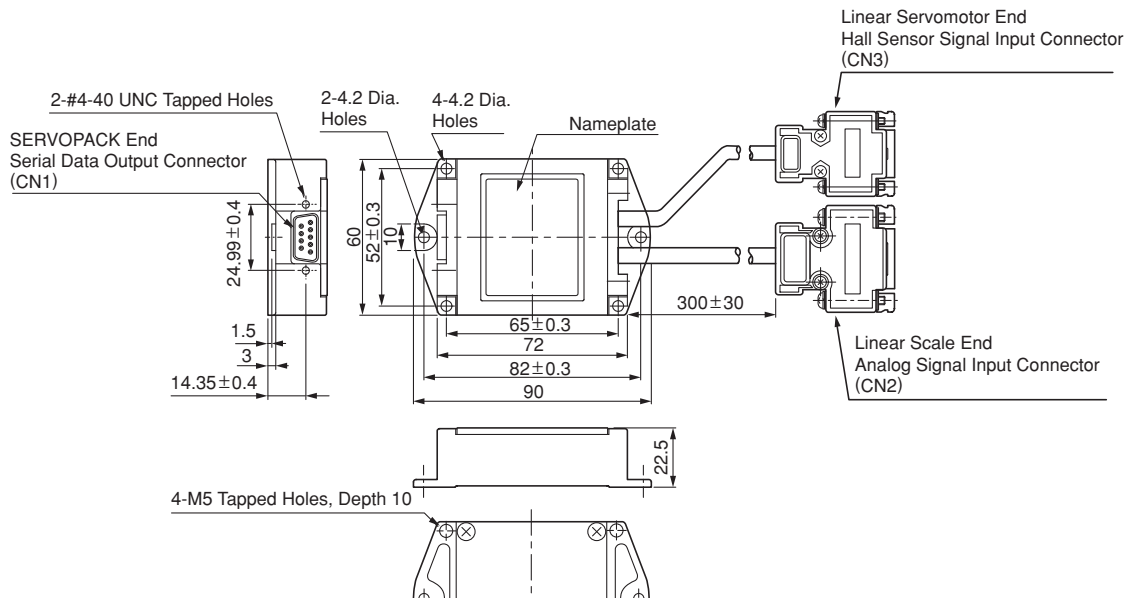

[CN1]
SERVOPACK End
Serial Data Output

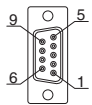

17-series Connector:
17LE-13090-27-FA
(Socket) by DDK Ltd.

[CN2]
Linear Scale End
Analog Signal Input

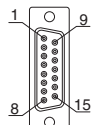

17-series Connector:
17JE-13150-02 (D8C) A-CG
(Socket) by DDK Ltd.

[CN3]
Linear Servomotor End
Hall Sensor Signal Input

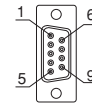

17-series Connector:
17JE-13090-02 (D8C) A-CG
by DDK Ltd.

Pin No.	Signal
1	+5V
2	Phase S output
3	Not used
4	Not used
5	0V
6	Phase /S output
7	Not used
8	Not used
9	Not used
Case	Shield

Pin No.	Signal
1	/cos input (V1-)
2	/sin input (V2-)
3	Ref input (V0+)
4	+5V
5	5Vs
6	Not used
7	Not used
8	Not used
9	cos input (V1+)
10	sin input (V2+)
11	/Ref input (V0-)
12	0 V
13	0 Vs
14	Not used
15	Inner
Case	Shield

Pin No.	Signal
1	+5V
2	Phase U input
3	Phase V input
4	Phase W input
5	0V
6	Not used
7	Not used
8	Not used
9	Not used
Case	Shield

- Notes: 1 Do not use the unused pins.
 2 Contact Renishaw plc. for details of connection cables (analog 1 Vp-p output, D-sub 15-pin, male) by Renishaw plc. However, the BID and DIR signals are not connected.
 3 Use the linear scale-end connector to change the zero point specifications of the linear scale.
 4 Phase U, V, and W input are internally pulled up at 10 kΩ.

Flexible Cables

● Life of Flexible Cable

The flexible cable supports 10,000,000 or more operations of bending life with the recommended bending radius R . The following table shows the recommended bending radius R of each cable.

Cable Type	Model	Recommended Bending Radius mm
Linear Servomotor Main Circuit Cables	JZSP-CLN11-□□-E	35
	JZSP-CLN21-□□-E	38
	JZSP-CLN39-□□-E	50
	JZSP-CLN14-□□-E	35
Cables for Connecting Linear Scales	JZSP-CLL00-□□-E	57
Cables for Connecting Hall Sensors	JZSP-CLL10-□□-E	46
Cables for Connecting Serial Converter Units	JZSP-CLP70-□□-E	46

● Conditions

- 1 Repeat moving one end of the cable forward and backward for 320 mm with using the test equipment shown in the following figure.
- 2 Connect the lead wires in parallel, and count the number of cable return motion times until a lead wire is disconnected. Note that one reciprocating is counted as one test.

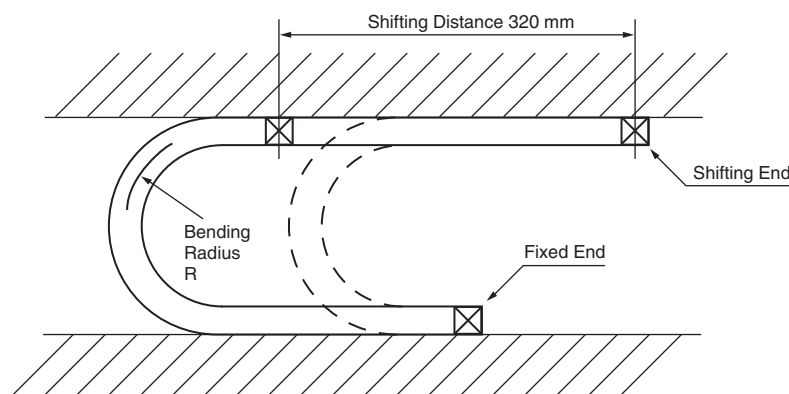

Notes: 1 The life of flexible cable differs largely depending on the amount of mechanical shocks, mounting to the cable, and fixing methods. The life of flexible cable is limited under the specified conditions.

2 The life of flexible cable indicates the number of bending times in which lead wires are electrically conducted and by which no cracks and damages that affects the performance of cable sheathing are caused. Disconnecting the shield wire is not taken into account.

● Wiring Precautions

Even if the recommended bending radius R is respected in the mechanical design, incorrect wiring may cause early disconnection. Observe the following precautions when wiring.

- (1) Cable twisting
Straighten the flexible cables before wiring.
Twisted cables cause early disconnection. Check the indication on the cable surface to make sure that the cable is not twisted.
- (2) Fixing method
Do not fix the moving points of the flexible cable. Stress on the fixed points may cause early disconnection. Fix the cable at the minimum number of points.
- (3) Cable length
If the cable length is too long, it may cause the cable's sagging. Besides the cable length is too short, it may cause the excessive tension on the fixed points that will cause early disconnection. Use a flexible cable with the optimum length.
- (4) Interference between cables
Avoid interference between cables.
Interference limits the motion of flexible cable, which causes early disconnection. Keep enough distance between cables, or provide a partition when wiring.

Linear Sliders

Σ-Trac

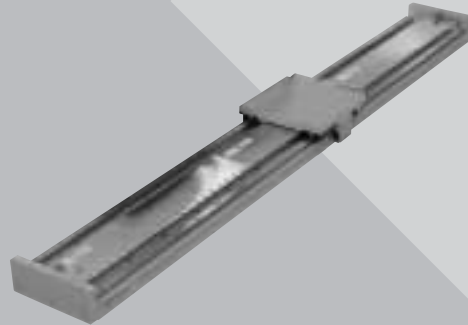

Model Designations

SGT 1 F3 1 - 030 A H 20 - 0

Σ-Trac Series
Linear Slider

Linear Slider Type
1 : Standard
(Aluminum base)
2 : High-rigidity
(Steel or iron base)

Mounted Linear
Servomotor

Moving Coil Model	Code
SGLFW-35A120A	F3
SGLFW-35A230A	F4
SGLFW-50A200B	F9
SGLFW-50A380B	FA
SGLGW-40A140C	GD
SGLGW-40A253C	GE
SGLGW-40A365C	GF
SGLGW-60A140C	GG
SGLGW-60A253C	GH
SGLGW-60A365C	GI

Number of Tables (per Axis)
1 : 1 table
2 : 2 tables
to
n : n tables

Surface Treatment

0 : Aluminum base; Clear anodized aluminum coating
Steel or iron base; Black paint
1 : Aluminum base; Black anodized aluminum coating
Steel or iron base; Electroless nickel plating or Raydent processing

Linear Scale Resolution

20 : 20 μm
04 : 4 μm

Linear Scale Manufacturer

H : HEIDENHAIN Corporation
R : Renishaw plc.

Linear Scale Output Form

A : Analog output 1 Vp-p

Stroke Length

007 : 70 mm
to
195 : 1950 mm

Features

- For long strokes and high-speed, high-accuracy positioning (repetitive positioning accuracy less than $\pm 1.0 \mu\text{m}$).
- Several tables can be mounted on one magnetic way, and each table can be driven independently.
- Standard and high-precision models are available.

Model Classification

• Force

SERVOPACK Model SGD V-		Σ -Trac Series Linear Sliders							
Single-phase 100 VAC	Three-phase 200 VAC	Model	Force	200 N	400 N	600 N	800 N	1000 N	1200 N
2R1F	1R6A	SGT□F3□-□□□							
-	3R8A	SGT□F4□-□□□						Rated force	Peak force
-	5R5A	SGT□F9□-□□□							
-	120A	SGT□FA□-□□□							
R90F	R90A	SGT□GD□-□□□							
2R1F	1R6A	SGT□GE□-□□□							
2R8F	2R8A	SGT□GF□-□□□							
2R1F	1R6A	SGT□GG□-□□□							
2R8F	2R8A	SGT□GH□-□□□							
-	5R5A	SGT□GI□-□□□							

• Stroke Length

Model	Stroke Length	500 mm	1000 mm	1500 mm	2000 mm
SGT□F3□-□□□	80 mm				1950 mm
SGT□F4□-□□□	180 mm				1830 mm
SGT□F9□-□□□	70 mm				1830 mm
SGT□FA□-□□□	170 mm				1650 mm
SGT□GD□-□□□	90 mm		1300 mm		
SGT□GE□-□□□	120 mm		1200 mm		
SGT□GF□-□□□	140 mm		1080 mm		
SGT□GG□-□□□	90 mm		1300 mm		
SGT□GH□-□□□	120 mm		1200 mm		
SGT□GI□-□□□	140 mm		1080 mm		

Contact your Yaskawa representative for information on strokes other than those listed.

SGT1F3□ and SGT1F4□ Linear Sliders

● Ratings and Specifications

Time Rating: Continuous

Insulation Resistance: 500 VDC, 10 MΩ min.

Ambient Temperature: 0 to 40°C

Excitation: Permanent magnet

Withstand Voltage: 1500 VAC for one minute

Enclosure: Self-cooled

Ambient Humidity: 20% to 80% (no condensation)

Allowable Winding Temperature: 130°C (Thermal class B)

Linear Slider Model*1		SGT1F3□-□□□AH20-0	SGT1F4□-□□□AH20-0
Mounted Linear Servomotor Model	SGLFW-	35A120AP	35A230AP
Applicable SERVOPACK Model	SGDV-	2R1F, 1R6A	3R8A
Applicable Serial Converter Unit Model	JZDP-	□006-019-E	□006-020-E
Rated Force	N	80	160
Peak Force	N	220	440
Force Constant	N / Arms	62.4	62.4
Motor Constant	N / \sqrt{W}	14.4	20.4
Maximum Payload*2, *3	kg	30	70
Movable Member Mass	kg	3.1	5.3
Total Mass	kg	See Table 1	See Table 2
Effective Stroke	mm	on the next page.	on the next page.
Resolution	μm	0.078 (20 μm / 256) *4	
		0.0049 (20 μm / 4096) *5	
Repeatability*6	μm	± 1.0	± 1.0

*1: Squares (□□□) are used to indicate the stroke length code shown in Tables 1 and 2.

*2: Values obtained when the acceleration is 4.9 m/s².

*3: Contact your Yaskawa representative if the expected payload exceeds the value indicated in the table.

*4: The value applies when serial converter unit JZDP-D00□-□□□-E is used.

*5: The value applies when serial converter unit JZDP-G00□-□□□-E is used.

*6: Values obtained when the ambient temperature is constant.

● Performance Curves

● Force - Speed

A : Continuous Duty Zone

B : Intermittent Duty Zone (Note)

(1) SGT1F3□

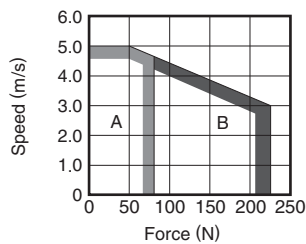

(2) SGT1F4□

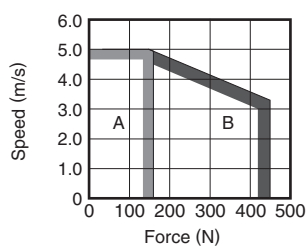

Note: When the effective force during intermittent duty is within the rated force, the servomotor can be used within the intermittent duty zone.

● Effective Force - Ambient Temperature

● Load Mass - Acceleration

When the sensor temperature is 50°C or less

Average speed (m/s) : 0 — 1 — 2 —

Note: Average speed = Total movement distance (m) / cycle time (s)

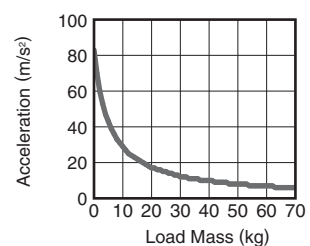
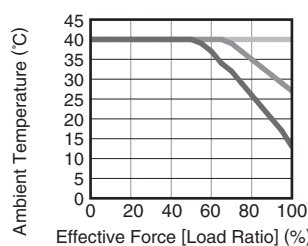
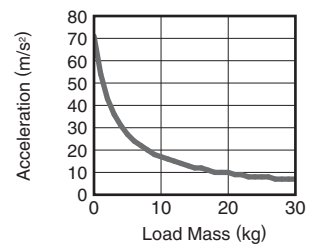
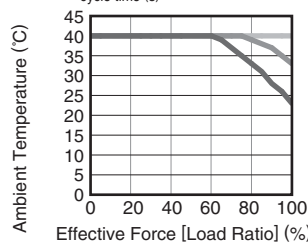

SGT1F3 and SGT1F4 Linear Sliders Units: mm

● External Dimensions

(1) SGT1F31

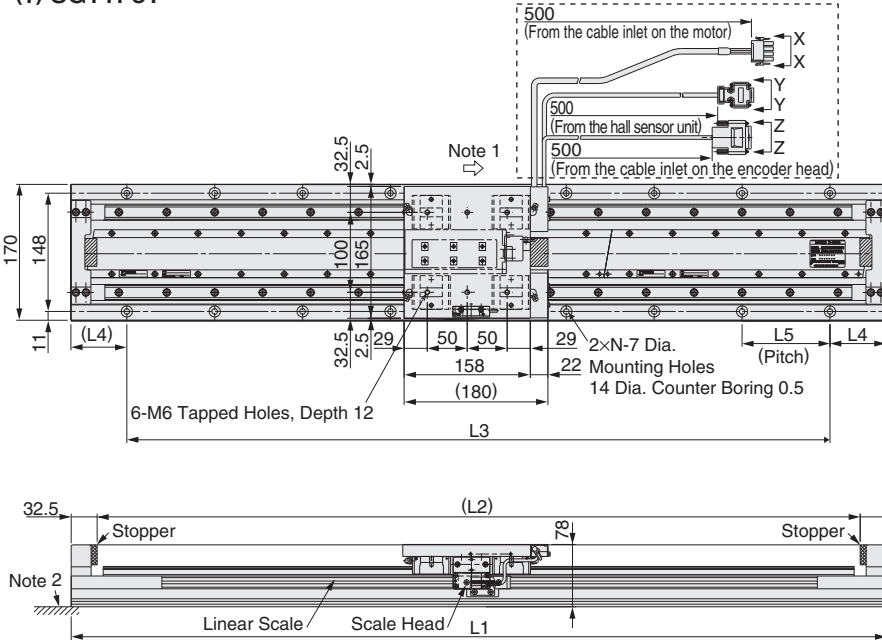

Table 1

Stroke Code	Length	L1 mm	L2 mm	L3 mm	L4 mm	L5 mm	N	Total Mass kg
008	80	360	295	270	45	90	4	9.1
030	300	580	515	440			5	13.0
041	410	690	625	550			6	14.9
052	520	800	735	660			7	16.8
063	630	910	845	770			8	18.6
074	740	1020	955	880			9	20.5
085	850	1130	1065	990			10	22.5
096	960	1240	1175	1100			11	24.5
107	1070	1350	1285	1210	70	110	12	26.3
118	1180	1460	1395	1320			13	28.3
129	1290	1570	1505	1430			14	30.1
140	1400	1680	1615	1540			15	32.0
151	1510	1790	1725	1650			16	34.0
162	1620	1900	1835	1760			17	35.9
173	1730	2010	1945	1870			18	37.8
184	1840	2120	2055	1980			19	39.7
195	1950	2230	2165	2090			20	41.5

(2) SGT1F41

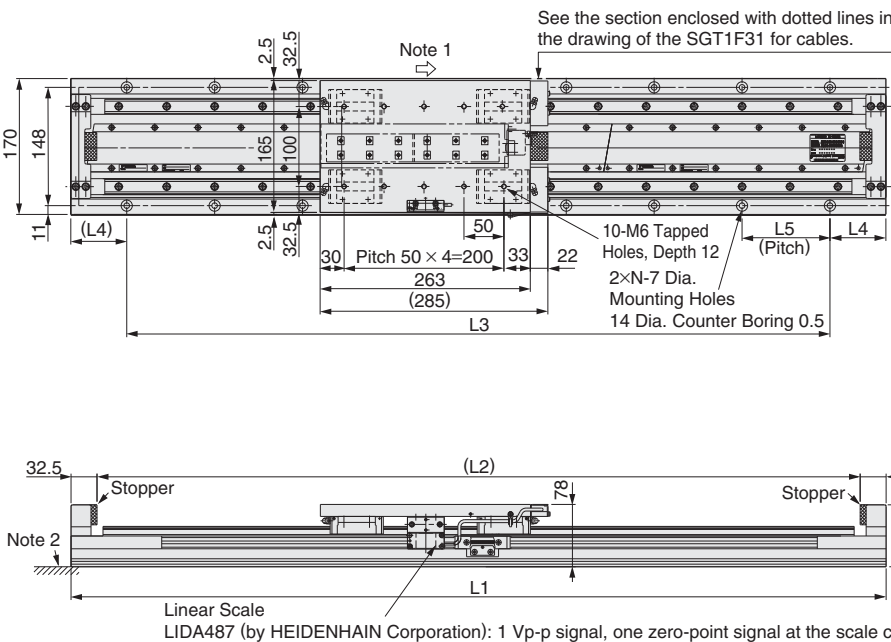

Table 2

Stroke Code	Length	L1 mm	L2 mm	L3 mm	L4 mm	L5 mm	N	Total Mass kg
018	180	580	515	440			5	15.1
029	290	690	625	550			6	17.0
040	400	800	735	660			7	18.9
051	510	910	845	770			8	20.7
062	620	1020	955	880			9	22.7
073	730	1130	1065	990			10	24.6
084	840	1240	1175	1100			11	27.1
095	950	1350	1285	1210	70	110	12	28.5
106	1060	1460	1395	1320			13	30.4
117	1170	1570	1505	1430			14	32.2
128	1280	1680	1615	1540			15	34.2
139	1390	1790	1725	1650			16	36.1
150	1500	1900	1835	1760			17	38.1
161	1610	2010	1945	1870			18	39.9
172	1720	2120	2055	1980			19	41.9
183	1830	2230	2165	2090			20	42.6

Notes: 1 The moving coil moves in the direction indicated by the arrow when current flows in the order of phase U, V, and W.
 2 When installing the linear slider, the surface should be flat to the equivalent of a maximum discrepancy of 0.02/200 mm (reference value).

• Connector Specifications for the Σ-Trac Series Linear Sliders (All Models)

View X-X

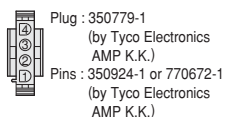

Pin No.	Signal
1	Phase-U output
2	Phase-V output
3	Phase-W output
4	FG

View Y-Y

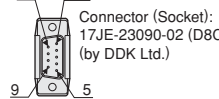

Pin No.	Signal	Pin No.	Signal
1	+5V (power supply)	6	Not used
2	Phase-U output	7	Not used
3	Phase-V output	8	Not used
4	Phase-W output	9	Not used
5	0V (power supply)	Case	Shield

View Z-Z

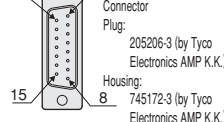

For Encoder Cable

Pin No.	Signal	Pin No.	Signal
1	Cos output (A+)	9	/Cos output (A-)
2	0 V	10	0 V sensor
3	Sin output (B+)	11	/Sin output (B-)
4	+5 V	12	5 V sensor
5	Not used	13	Not used
6	Not used	14	/Ref (R+)
7	/Ref (R-)	15	Not used
8	Not used	Case	Shield

SGT1F9□ and SGT1FA□ Linear Sliders

● Ratings and Specifications

Time Rating: Continuous
 Insulation Resistance: 500 VDC, 10 MΩ min.
 Ambient Temperature: 0 to 40°C
 Excitation: Permanent magnet

Withstand Voltage: 1500 VAC for one minute
 Enclosure: Self-cooled
 Ambient Humidity: 20% to 80% (no condensation)
 Allowable Winding Temperature: 130°C (Thermal class B)

Linear Slider Model*1		SGT1F9□-□□□AH20-0	SGT1FA□-□□□AH20-0
Mounted Linear Servomotor Model	SGLFW-	50A200BP	50A380BP
Applicable SERVOPACK Model	SGDV-	5R5A	120A
Applicable Serial Converter Unit Model	JZDP-	□006-181-E	□006-182-E
Rated Force	N	280	560
Peak Force	N	600	1200
Force Constant	N / Arms	60.2	60.2
Motor Constant	N / √W	34.3	48.5
Maximum Payload*2, *3	kg	100	215
Movable Member Mass	kg	7.2	12.9
Total Mass	kg	See Table 1 on the next page.	See Table 2 on the next page.
Effective Stroke	mm		
Resolution	μm	0.078 (20 μm / 256) *4	
		0.0049 (20 μm / 4096) *5	
Repeatability*6	μm	±1.0	

*1: Squares (□□□) are used to indicate the stroke length code shown in Tables 1.
 *2: Values obtained when the acceleration is 4.9 m/s².
 *3: Contact your Yaskawa representative if the expected payload exceeds the value indicated in the table.
 *4: The value applies when serial converter unit JZDP-D00□-□□□-E is used.
 *5: The value applies when serial converter unit JZDP-G00□-□□□-E is used.
 *6: Values obtained when the ambient temperature is constant.

● Performance Curves

● Force - Speed

A : Continuous Duty Zone
B : Intermittent Duty Zone (Note)

(1) SGT1F9□

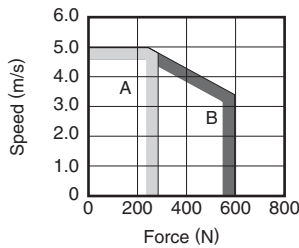

(2) SGT1FA□

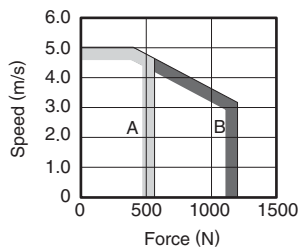

Note: When the effective force during intermittent duty is within the rated force, the servomotor can be used within the intermittent duty zone.

● Effective Force - Ambient Temperature ● Load Mass - Acceleration

When the sensor temperature is 50°C or less

Average speed (m/s) : 0 — 1 — 2 —

Note: Average speed = Total movement distance (m) / cycle time (s)

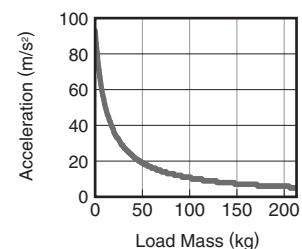
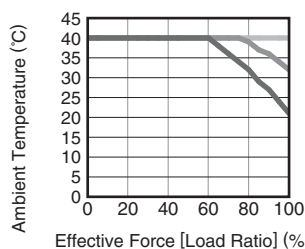
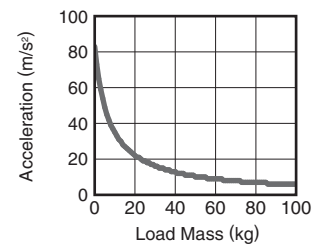
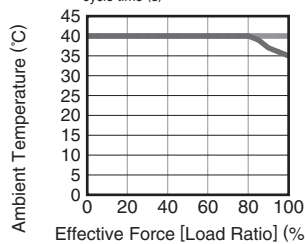

SGT1F9 and SGT1FA Linear Sliders Units: mm

● External Dimensions

(1) SGT1F91

(See page 232 for details on each connector specifications.)

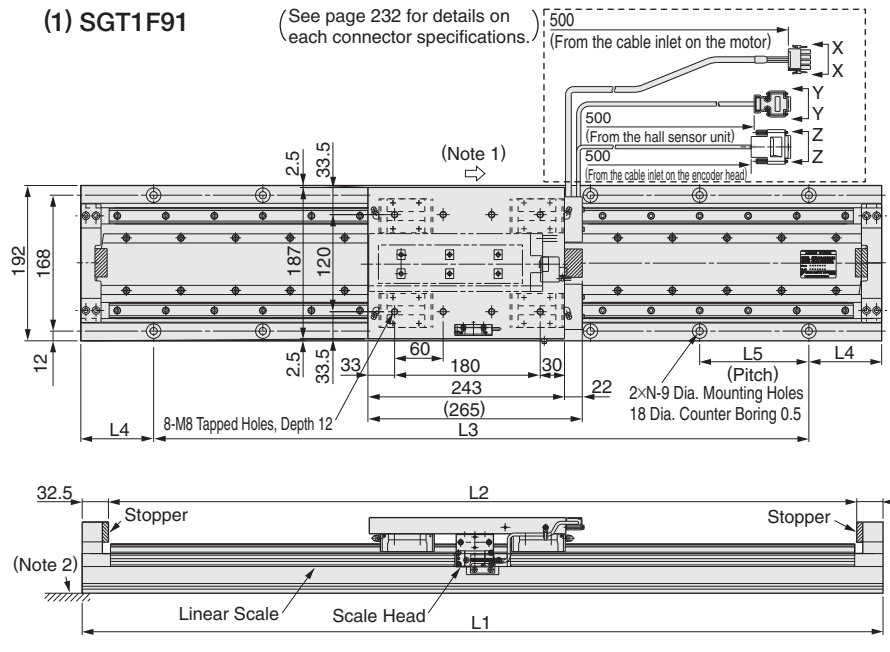

Table 1

Stroke Code	Length	L1 mm	L2 mm	L3 mm	L4 mm	L5 mm	N	Total Mass kg
007	70	440	375	300	70	100	4	15.9
035	350	720	655	540	90		5	21.3
048	480	850	785	675	87.5		6	24.1
062	620	990	925	810	90		7	26.9
075	750	1120	1055	945	87.5		8	29.5
089	890	1260	1195	1080	90		9	32.2
102	1020	1390	1325	1215	87.5		10	35.0
116	1160	1530	1465	1350	90	135	11	37.7
129	1290	1660	1595	1485	87.5		12	40.3
143	1430	1800	1735	1620	90		13	43.0
156	1560	1930	1865	1755	87.5		14	45.8
170	1700	2070	2005	1890	90		15	48.5
183	1830	2200	2135	2025	87.5		16	51.2

(2) SGT1FA1

(See the section enclosed with dotted lines in the drawing of the SGT1F91 for cables.)

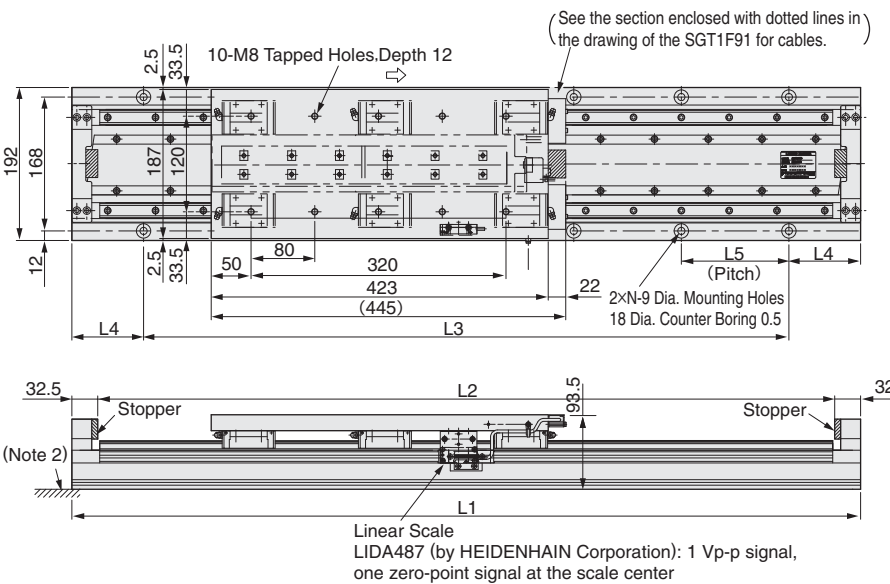

Table 2

Stroke Code	Length	L1 mm	L2 mm	L3 mm	L4 mm	L5 mm	N	Total Mass kg
017	170	720	655	540	90		5	27.0
030	300	850	785	675	87.5		6	29.8
044	440	990	925	810	90		7	32.6
057	570	1120	1055	945	87.5		8	35.2
071	710	1260	1195	1080	90		9	37.9
084	840	1390	1325	1215	87.5		10	40.7
098	980	1530	1465	1350	90	135	11	43.4
111	1110	1660	1595	1485	87.5		12	46.0
125	1250	1800	1735	1620	90		13	48.7
138	1380	1930	1865	1755	87.5		14	51.5
152	1520	2070	2005	1890	90		15	54.2
165	1650	2200	2135	2025	87.5		16	56.9

Notes: 1 The moving coil moves in the direction indicated by the arrow when current flows in the order of phase U, V, and W.
2 When installing the linear slider, the surface should be flat to the equivalent of a maximum discrepancy of 0.02/200 mm (reference value).

SGT1GD□, SGT1GE□, and SGT1GF□ Linear Sliders

● Ratings and Specifications

Time Rating: Continuous
 Insulation Resistance: 500 VDC, 10 MΩ min.
 Ambient Temperature: 0 to 40°C
 Excitation: Permanent magnet

Withstand Voltage: 1500 VAC for one minute
 Enclosure: Self-cooled, fan-cooled
 Ambient Humidity: 20% to 80% (no condensation)
 Allowable Winding Temperature: 130°C (Thermal class B)

Linear Slider Model*1		SGT1GD□-□□□AH20-0	SGT1GE□-□□□AH20-0	SGT1GF□-□□□AH20-0
Mounted Linear Servomotor Model	SGLGW-	40A140CP	40A253CP	40A365CP
Applicable SERVOPACK Model	SGDV-	R90F, R90A	2R1F, 1R6A	2R8F, 2R8A
Applicable Serial Converter Unit Model	JZDP-	□006-252-E	□006-253-E	□006-254-E
Rated Force	N	47	93	140
Peak Force	N	140	280	420
Force Constant	N / Arms	61.5	61.5	61.5
Motor Constant	N / √W	7.8	11	13.5
Maximum Payload*2, *3	kg	25	50	80
Movable Member Mass	kg	2.8	3.7	5.5
Total Mass	kg	See Table 1 on the next page.		
Effective Stroke	mm			
Resolution	μm	0.078 (20 μm / 256) *4		
Repeatability*6	μm	0.0049 (20 μm / 4096) *5		
		±1.0	±1.0	±1.0

*1: Squares (□□□) are used to indicate the stroke length code shown in Table 1.
 *2: Values obtained when the acceleration is 4.9 m/s².
 *3: Contact your Yaskawa representative if the expected payload exceeds the value indicated in the table.
 *4: The value applies when serial converter unit JZDP-D00□-□□□-E is used.
 *5: The value applies when serial converter unit JZDP-G00□-□□□-E is used.
 *6: Values obtained when the ambient temperature is constant.

● Performance Curves

● Force - Speed

A: Continuous Duty Zone
B: Intermittent Duty Zone (Note)

(1) SGT1GD□

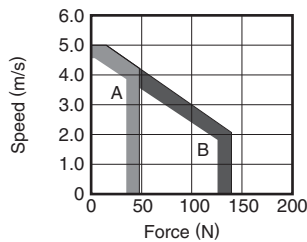

(2) SGT1GE□

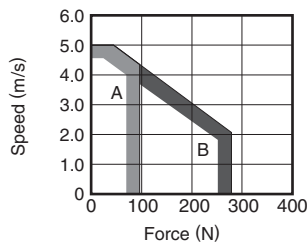

(3) SGT1GF□

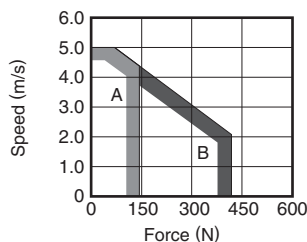

Note: When the effective force during intermittent duty is within the rated force, the servomotor can be used within the intermittent duty zone.

● Effective Force - Ambient Temperature ● Load Mass - Acceleration

When the sensor temperature is 50°C or less
 Average speed (m/s): 0 — 1 — 2 —
 Note: Average speed = Total movement distance (m) / cycle time (s)

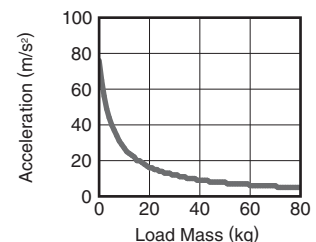
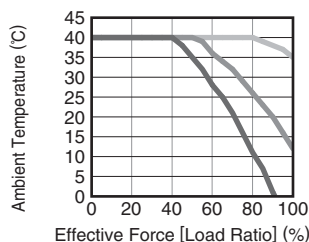
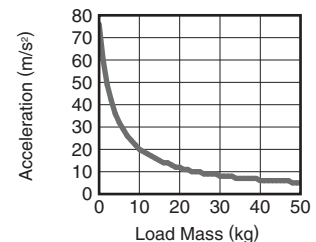
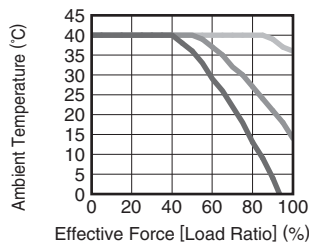
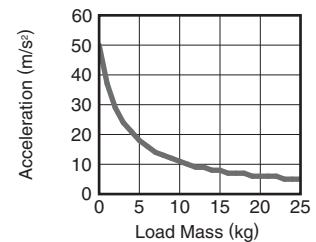
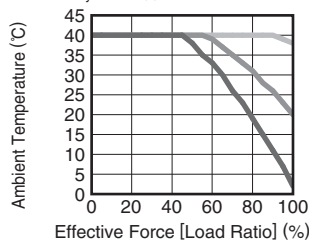

SGT1GD□, SGT1GE□, and SGT1GF□ Linear Sliders Units: mm

● External Dimensions

<Table Side View>

● SGT1GD1

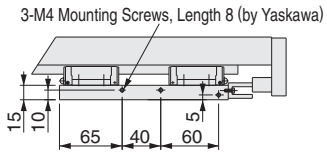

● SGT1GE1

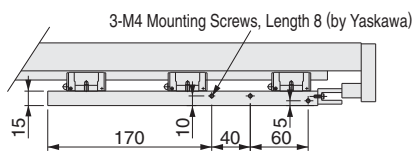

● SGT1GF1

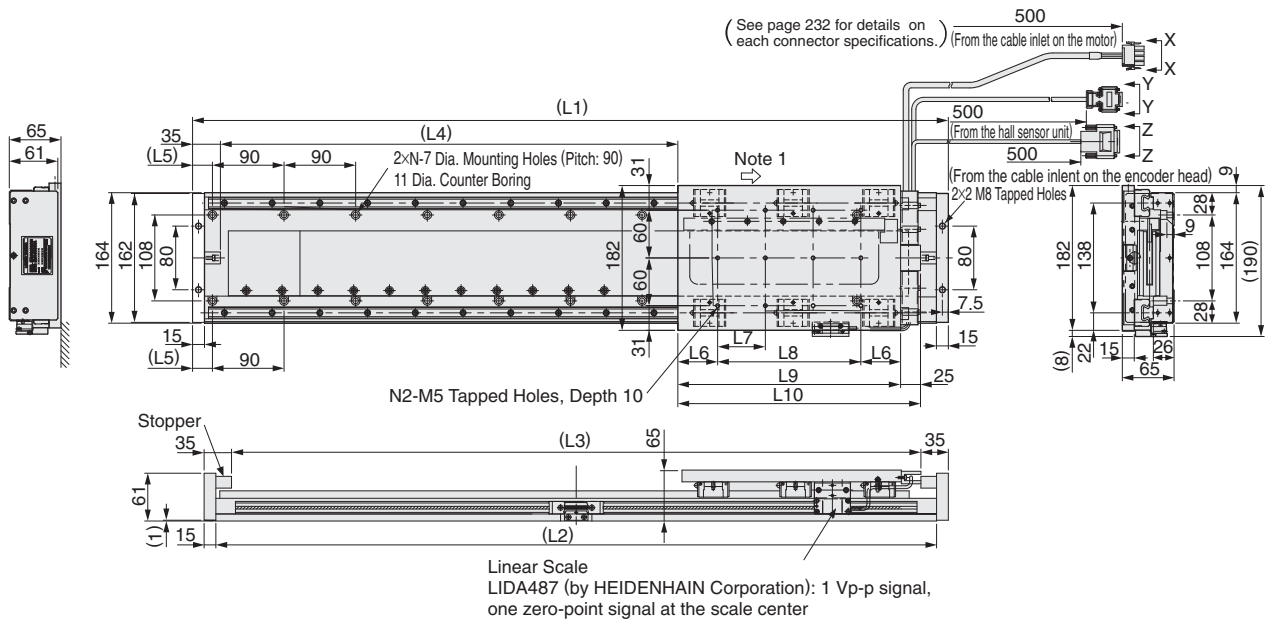
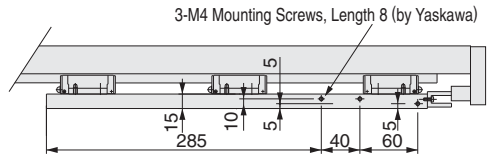

Table 1

Linear Slider Model (Mounted Linear Servomotor Model)	Stroke		Dimensions mm										N	N2	Total Mass kg
	Code	Length	L1	L2	L3	L4	L5	L6	L7	L8	L9	L10			
SGT1GD1-□□□*AH20-0 (SGLGW-40A140CP)	009	90	410	380	340	140	25	32.5	55	110	175	200	5	9	12.3
	022	220	545	515	475	275	47.5						6		15.3
	036	360	680	650	610	410	25						8		18.4
	049	490	815	785	745	545	47.5						9		21.5
	063	630	950	920	880	680	25						11		24.5
	076	760	1085	1055	1015	815	47.5						12		27.6
	090	900	1220	1190	1150	950	25						14		30.6
	103	1030	1355	1325	1285	1085	47.5						15		33.7
	117	1170	1490	1460	1420	1220	25						17		36.8
	130	1300	1625	1595	1555	1355	47.5						18		39.8
SGT1GE1-□□□*AH20-0 (SGLGW-40A253CP)	012	120	545	515	475	170	47.5	50	60	180	280	305	6	12	16.8
	025	250	680	650	610	305	25						8		19.9
	039	390	815	785	745	440	47.5						9		22.9
	052	520	950	920	880	575	25						11		26.0
	066	660	1085	1055	1015	710	47.5						12		29.0
	079	790	1220	1190	1150	845	25						14		32.1
	093	930	1355	1325	1285	980	47.5						15		35.2
	106	1060	1490	1460	1420	1115	25						17		38.2
	110	1100	1535	1505	1465	1160	47.5						17		39.3
	120	1200	1625	1595	1555	1250	47.5						18		41.3
SGT1GF1-□□□*AH20-0 (SGLGW-40A365CP)	014	140	680	650	610	190	25	47.5	60	300	395	420	8	18	21.1
	027	270	815	785	745	325	47.5						9		24.2
	041	410	950	920	880	460	25						11		27.3
	054	540	1085	1055	1015	595	47.5						12		30.3
	068	680	1220	1190	1150	730	25						14		33.4
	081	810	1355	1325	1285	865	47.5						15		36.4
	095	950	1490	1460	1420	1000	25						17		39.5
	108	1080	1625	1595	1555	1135	47.5						18		42.6

*: Squares (□□□) are used to indicate the stroke length code shown in Table 1.

Notes: 1 The moving coil moves in the direction indicated by the arrow when current flows in the order of phase U, V, and W.

2 When installing the linear slider, the surface should be flat to the equivalent of a maximum discrepancy of 0.02/200 mm (reference value).

Linear Sliders

SGT1GG□, SGT1GH□, and SGT1GI□ Linear Sliders

● Ratings and Specifications

Time Rating: Continuous

Insulation Resistance: 500 VDC, 10 MΩ min.

Ambient Temperature: 0 to 40°C

Excitation: Permanent magnet

Withstand Voltage: 1500 VAC for one minute

Enclosure: Self-cooled, fan-cooled

Ambient Humidity: 20% to 80% (no condensation)

Allowable Winding Temperature: 130°C (Thermal class B)

Linear Slider Model*1		SGT1GG□-□□□AH20-0	SGT1GH□-□□□AH20-0	SGT1GI□-□□□AH20-0
Mounted Linear Servomotor Model	SGLGW-	60A140CP	60A253CP	60A365CP
Applicable SERVOPACK Model	SGDV-	2R1F, 1R6A	2R8F, 2R8A	5R5A
Applicable Serial Converter Unit Model	JZDP-	□006-258-E	□006-259-E	□006-260-E
Rated Force	N	70	140	210
Peak Force	N	220	440	660
Force Constant	N / Arms	66.6	66.6	66.6
Motor Constant	N / \sqrt{W}	11.1	15.7	19.2
Maximum Payload*2, *3	kg	40	80	110
Movable Member Mass	kg	2.9	3.9	5.7
Total Mass	kg	See Table 1 on the next page.		
Effective Stroke	mm			
Resolution	μm	0.078 (20 μm / 256) *4		
		0.0049 (20 μm / 4096) *5		
Repeatability*6	μm	±1.0	±1.0	±1.0

*1: Squares (□□□) are used to indicate the stroke length code shown in Table 1.

*2: Values obtained when the acceleration is 4.9 m/s².

*3: Contact your Yaskawa representative if the expected payload exceeds the value indicated in the table.

*4: The value applies when serial converter unit JZDP-D00□-□□□-E is used.

*5: The value applies when serial converter unit JZDP-G00□-□□□-E is used.

*6: Values obtained when the ambient temperature is constant.

● Performance Curves

● Force - Speed

- A : Continuous Duty Zone
- B : Intermittent Duty Zone (Note)

(1) SGT1GG□

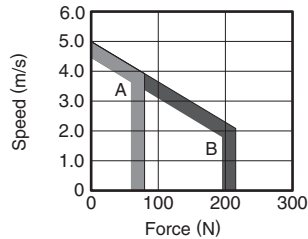

(2) SGT1GH□

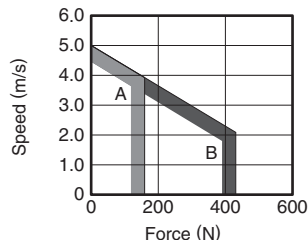

(3) SGT1GI□

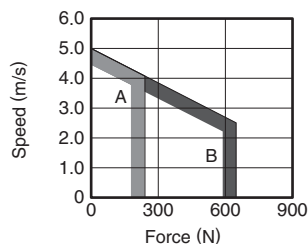

● Effective Force - Ambient Temperature

When the sensor temperature is 50°C or less

Average speed (m/s) : 0 — 1 — 2

Note: Average speed = Total movement distance (m) / cycle time (s)

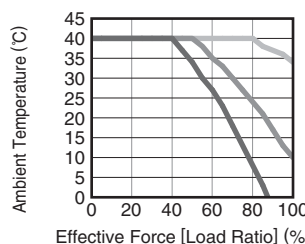
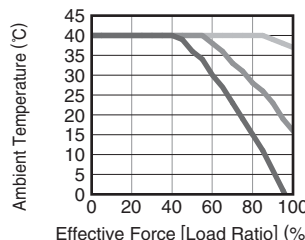
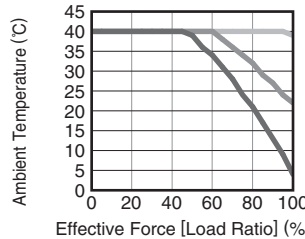

● Load Mass - Acceleration

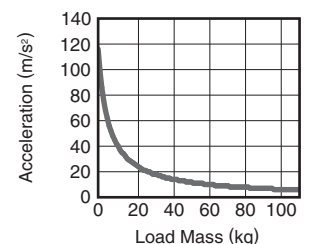
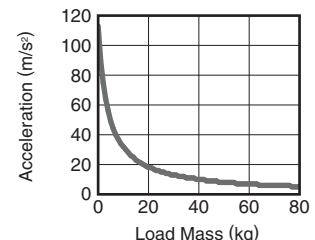
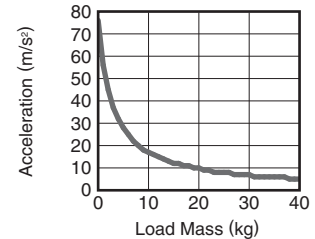

Note: When the effective force during intermittent duty is within the rated force, the servomotor can be used within the intermittent duty zone.

SGT1GG□, SGT1GH□, and SGT1GI□ Linear Sliders Units: mm

● External Dimensions

<Table Side View>

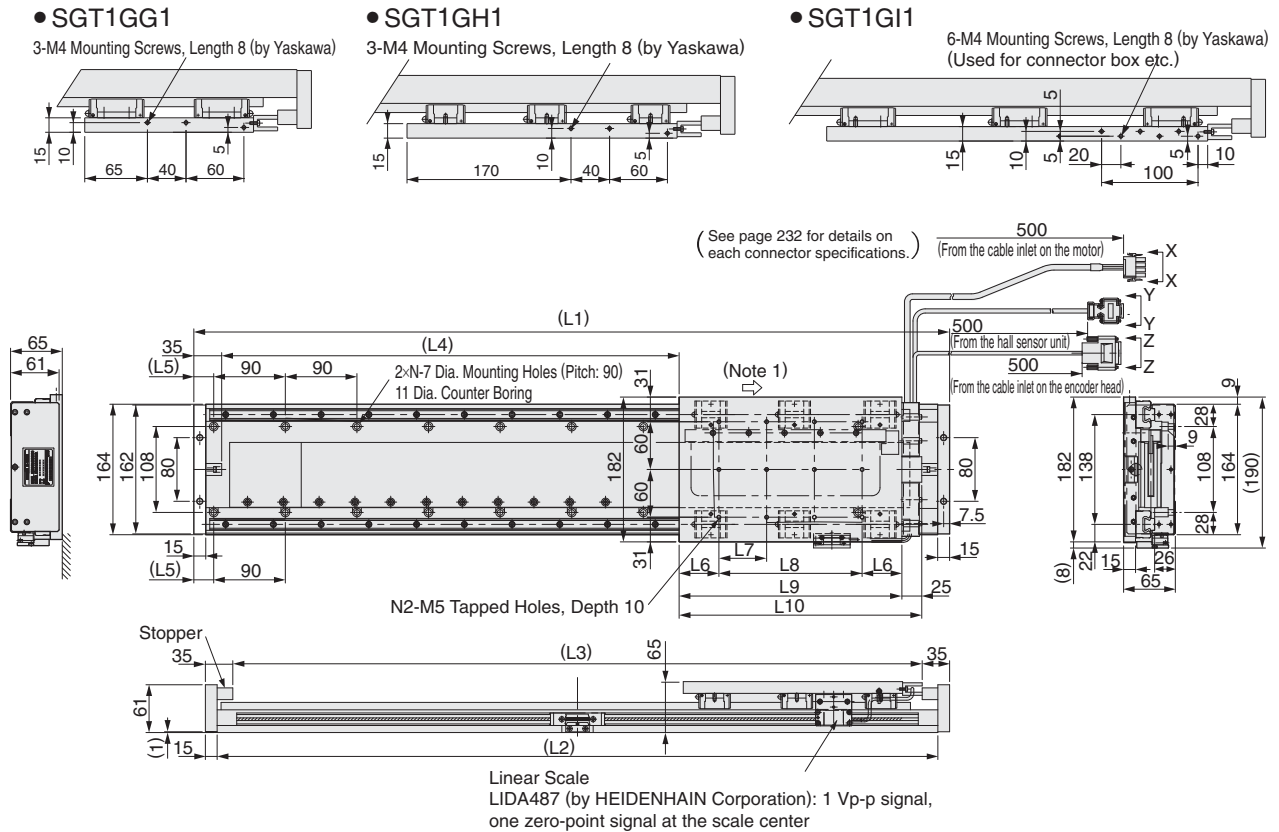

Table 1

Linear Slider Model (Mounted Linear Servomotor Model)	Stroke		Dimensions mm										N	N2	Total Mass kg
	Code	Length	L1	L2	L3	L4	L5	L6	L7	L8	L9	L10			
SGT1GG1-□□□*AH20-0 (SGLGW-60A140CP)	009	90	410	380	340	140	25	32.5	55	110	175	200	5	9	12.3
	022	220	545	515	475	275	47.5						6		15.4
	036	360	680	650	610	410	25						8		18.5
	049	490	815	785	745	545	47.5						9		21.5
	063	630	950	920	880	680	25						11		24.6
	076	760	1085	1055	1015	815	47.5						12		27.7
	090	900	1220	1190	1150	950	25						14		30.7
	103	1030	1355	1325	1285	1085	47.5						15		33.8
	117	1170	1490	1460	1420	1220	25						17		36.9
	130	1300	1625	1595	1555	1355	47.5						18		39.9
SGT1GH1-□□□*AH20-0 (SGLGW-60A253CP)	012	120	545	515	475	170	47.5	50	60	180	280	305	6	12	17.0
	025	250	680	650	610	305	25						8		20.0
	039	390	815	785	745	440	47.5						9		23.1
	052	520	950	920	880	575	25						11		26.1
	066	660	1085	1055	1015	710	47.5						12		29.2
	079	790	1220	1190	1150	845	25						14		32.3
	093	930	1355	1325	1285	980	47.5						15		35.3
	106	1060	1490	1460	1420	1115	25						17		38.4
	110	1100	1535	1505	1465	1160	47.5						17		39.4
	120	1200	1625	1595	1555	1250	47.5						18		41.5
SGT1GI1-□□□*AH20-0 (SGLGW-60A365CP)	014	140	680	650	610	190	25	47.5	60	300	395	420	8	18	21.4
	027	270	815	785	745	325	47.5						9		24.4
	041	410	950	920	880	460	25						11		27.5
	054	540	1085	1055	1015	595	47.5						12		30.5
	068	680	1220	1190	1150	730	25						14		33.6
	081	810	1355	1325	1285	865	47.5						15		36.7
	095	950	1490	1460	1420	1000	25						17		39.7
	108	1080	1625	1595	1555	1135	47.5						18		42.8

*: Squares (□□□) are used to indicate the stroke length code shown in Table 1.

Notes: 1 The moving coil moves in the direction indicated by the arrow when current flows in the order of phase U, V, and W.

2 When installing the linear slider, the surface should be flat to the equivalent of a maximum discrepancy of 0.02/200 mm (reference value).

Selecting Cables and Connectors

● Connection diagrams

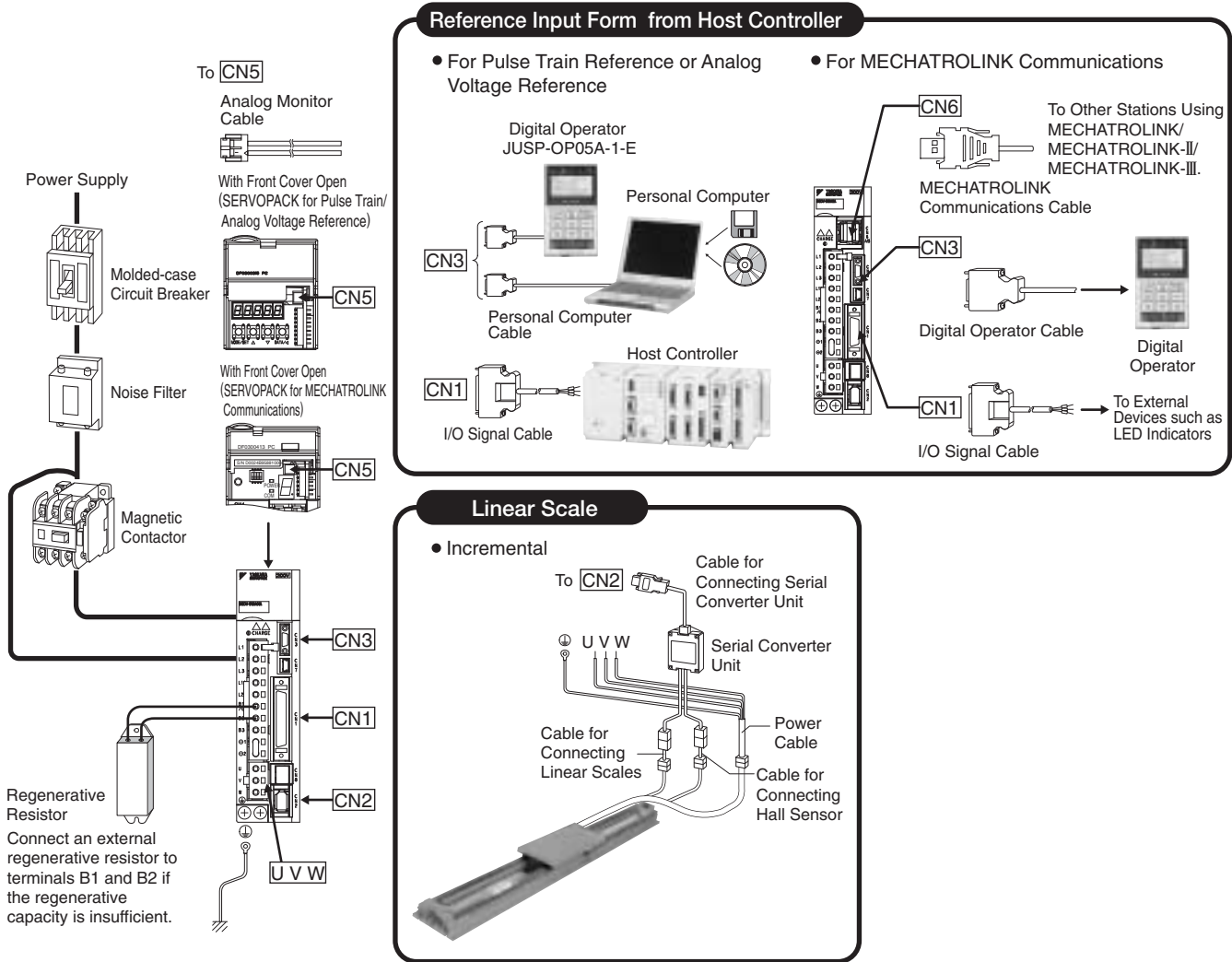

● Applicable Cables and Connectors

Motor Type	Linear Scale Type	Servo Drive			Motor Cable		Linear Scale Connection Cables		
		Σ-Trac Series Model	SERVOPACK Model SGD-V		SERVOPACK ↔ Motor	Serial Converter Unit Model JZDP-	[CN2] ↔ Serial Converter Unit	Serial Converter Unit ↔ Linear Scale	
			Single-phase 100 V	Three-phase 200 V			Power Cable (Flexible Type)	Cable for Connecting Serial Converter Unit (Flexible Type)	Cable for Connecting Linear Scales (Flexible Type)
Moving Coil (MC)	Incremental	SGT□F3□-□□□AH20-0	2R1F	1R6A	JZSP-CLN11-□□-E	□006-019-E	JZSP-CLP70-□□-E	JZSP-CLL00-□□-E*1	[The numbers in the boxes(□□) indicate the cable length. 01 = 1 m 03 = 3 m 05 = 5 m 10 = 10 m 15 = 15 m 20 = 20 m]
		SGT□F4□-□□□AH20-0	-	3R8A	JZSP-CLN11-□□-E	□006-020-E			
		SGT□F9□-□□□AH20-0	-	5R5A	JZSP-CLN21-□□-E	□006-181-E			
		SGT□FA□-□□□AH20-0	-	120A	JZSP-CLN21-□□-E	□006-182-E			
		SGT□GD□-□□□AH20-0	R90F	R90A	JZSP-CLN11-□□-E	□006-252-E			
		SGT□GE□-□□□AH20-0	2R1F	1R6A	JZSP-CLN11-□□-E	□006-253-E			
		SGT□GF□-□□□AH20-0	2R8F	2R8A	JZSP-CLN11-□□-E	□006-254-E			
		SGT□GG□-□□□AH20-0	2R1F	1R6A	JZSP-CLN11-□□-E	□006-258-E			
		SGT□GH□-□□□AH20-0	2R8F	2R8A	JZSP-CLN11-□□-E	□006-259-E			
		SGT□GI□-□□□AH20-0	-	5R5A	JZSP-CLN11-□□-E	□006-260-E			

Selecting Cables and Connectors

● Detail Drawings: Serial Converter Units for Linear Scales by HEIDENHAIN Corporation

● JZDP-□006-□□□-E
(With Hall Sensor Cable)

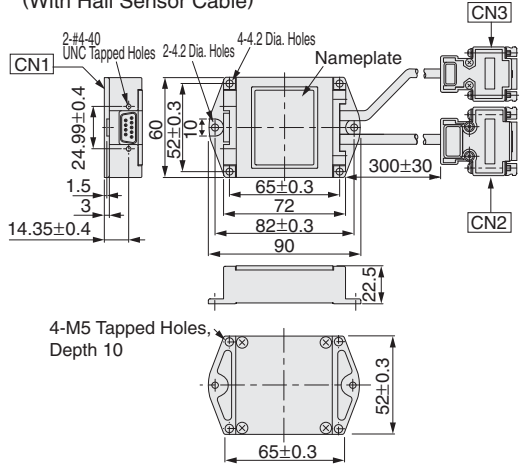

● JZDP-□003-□□□-E
(Without Hall Sensor Cable)

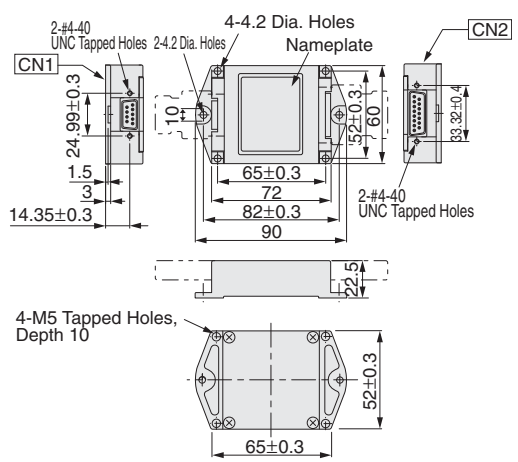

● Details on Connectors

CN1

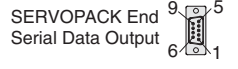

SERVOPACK End Serial Data Output
17-series Connector :
17LE-13090-27-FA (Socket)
by DDK Ltd.

Pin No.	Signal	Pin No.	Signal
1	+5V	6	Phase-S output
2	Phase-S output	7	Not used
3	Not used	8	Not used
4	Not used	9	Not used
5	0V	Case	Shield

CN2

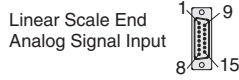

Linear Scale End Analog Signal Input
17-series Connector :
17JE-13150-02 (D8C) A-CG
(Socket) by DDK Ltd.

Pin No.	Signal	Pin No.	Signal
1	cos input (A+)	9	/cos input (A-)
2	0V	10	0V sensor
3	sin input (B+)	11	/sin input (B-)
4	+5V	12	5V sensor
5	Not used	13	Not used
6	Not used	14	Ref input (R+)
7	/Ref input (R-)	15	Not used
8	0V	Case	Shield

CN3

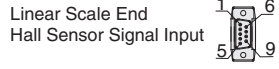

Linear Scale End Hall Sensor Signal Input
17-series Connector :
17JE-13090-02 (D8C) A-CG
(Socket) by DDK Ltd.

Pin No.	Signal	Pin No.	Signal
1	+5V	6	Not used
2	Phase-U output	7	Not used
3	Phase-V output	8	Not used
4	Phase-W output	9	Not used
5	0V	Case	Shield

Serial Converter Unit+Hall Sensor	Pulse-train or Analog Voltage Reference		MECHATROLINK Communications		Cables for Setting Devices/Monitors [CN5]	
	I/O Signal Connector [CN1]	I/O Signal Connector [CN1]	MECHATROLINK-II Communications Connector [CN6A] or [CN6B]	MECHATROLINK-III Communications Cable [CN6A] or [CN6B]		
Cable for Connecting Hall Sensor (Flexible Type)	Connector Terminal Block Converter Unit	Cable with Loose Wires at One End	Connector Terminal Block Converter Cable		Analog Monitor Cable	
JZSP-CLL10-□□-E The numbers in the boxes (□□) indicate the cable length. 01 = 1 m 03 = 3 m 05 = 5 m 10 = 10 m 15 = 15 m	JUSP-TA50PG-E (with a 0.5 m cable)	JZSP-CSI01-□-E*2 The number in the box (□) indicates the cable length. 1 = 1 m 2 = 2 m 3 = 3 m	JZSP-TA26P-□-E*2 □ → None = 0.5 m 1 = 1 m 2 = 2 m	MECHATROLINK communications cable: JEPMC-W6002-□□-E The numbers in the boxes (□□) indicate the cable length. A5 = 0.5 m 20 = 20 m 01 = 1 m 30 = 30 m 03 = 3 m 40 = 40 m 05 = 5 m 50 = 50 m 10 = 10 m MECHATROLINK terminator: JEPMC-W6022-E	The numbers in the boxes (□□) indicate the cable length. JEPMC-W6012-□□-E A2 = 0.2 m 05 = 5 m A5 = 0.5 m 10 = 10 m 01 = 1 m 20 = 20 m 02 = 2 m 30 = 30 m 03 = 3 m 50 = 50 m 04 = 4 m JEPMC-6013-□□-E*3 10 = 10 m 50 = 50 m 20 = 20 m 75 = 75 m 30 = 30 m JEPMC-6014-□□-E A5 = 0.5 m 10 = 10 m 01 = 1 m 30 = 30 m 03 = 3 m 50 = 50 m 05 = 5 m	JZSP-CA01-E (1 m)

*1: When using serial converter unit JZDP-G00□-□□□-E, the maximum cable length should be 3 m.
*2: A connector kit is required to assemble the cable. For details, refer to SERVOPACKs in this catalog.
*3: Currently in pre-release. Will be available soon.

Linear Sliders

Σ -Trac- μ

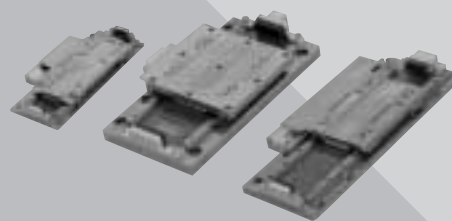

Model Designations

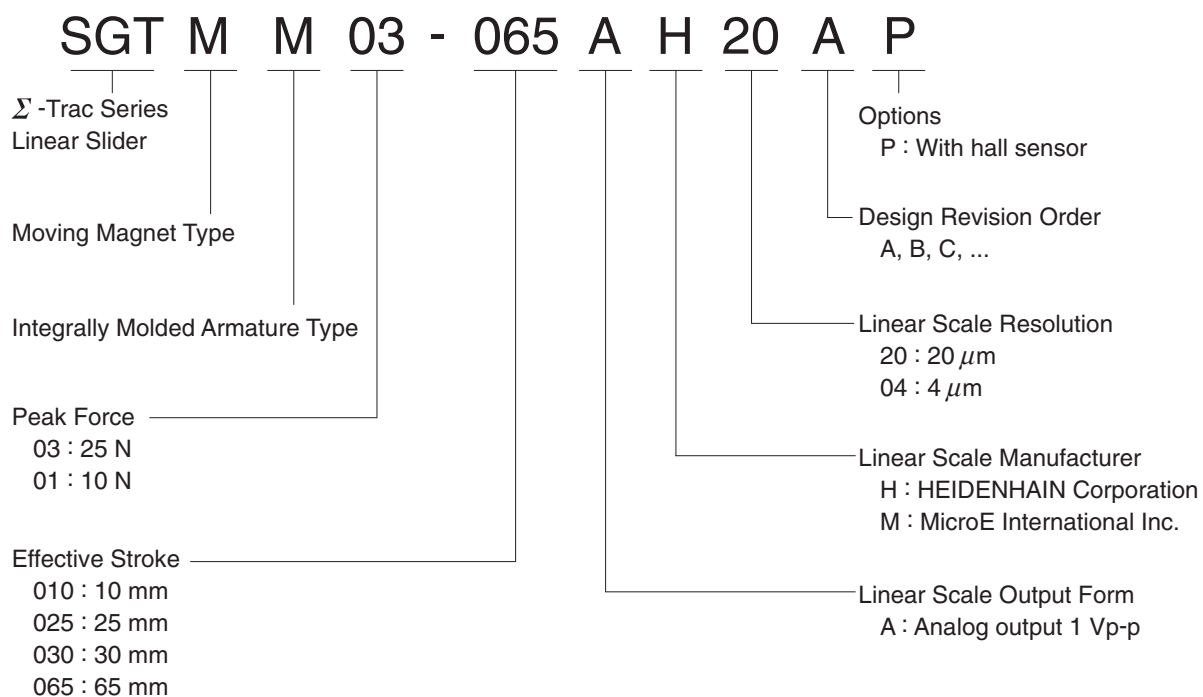

Features

- Ultra-flat profile reduces floorspace requirements.
- For applications requiring short strokes (10 mm to 65 mm)
- Vibration-free transmission device enables high-precision positioning with a repetitive positioning accuracy of $\pm 0.5 \mu\text{m}$ max.
- Locations of armature coils on fixed side of the stationary member reduce effects of heat on table or workpiece.

Application Examples

- Semiconductor mounters
- Equipment for biomedical
- Optical testing devices

Model Classification

● Force

SERVOPACK Model SGD V-		Σ -Trac- μ Series Linear Sliders						
Single-phase 100 VAC	Three-phase 200 VAC	Model	Force	10 N	20 N	30 N	Rated force	Peak force
R70F	R70A	SGTMM01						
R90F	R90A	SGTMM03						

● Stroke Length

Model	Stroke Length	50mm	100mm	150mm	200mm
SGTMM01	● 10 mm ● 30 mm				
SGTMM03	● 25 mm ● 65 mm				

SGTMM Linear Sliders

● Ratings and Specifications

Time Rating: Continuous

Insulation Resistance: 500 VDC, 10 MΩ min.

Ambient Temperature: 0°C to 40°C

Excitation: Permanent magnet

Dielectric Strength: 1500 VAC for one minute

Protection Method: Self-cooled

Ambient Humidity: 20% to 80% (no condensation)

Allowable Winding Temperature: 130°C (Thermal class B)

Linear Slider Model		SGTMM01-010AM20A	SGTMM01-030AM20A	SGTMM03-025AH20AP	SGTMM03-025AH04AP	SGTMM03-065AH20A□	SGTMM03-065AH04AP	
Applicable SERVOPACK Model	SGDV-	R70F, R70A			R90F, R90A			
Applicable Serial Converter Unit Model	JZDP-	□003-242-E			□00□-221-E		□00□-220-E	
Rated Force	N	3.5	3.5	7	7	7	7	
Peak Force	N	10	10	25	25	25	25	
Force Constant	N/Arms	9	9	13.2	13.2	12.3	12.3	
Motor Constant	N/√W	1.78	1.26	2.29	2.29	1.58	1.58	
Maximum Payload*1	kg	1	1	3	3	3	3	
Effective Stroke	mm	10	30	25	25	65	65	
Resolution	μm	0.078 (20 μm/256)*2			0.016 (4 μm/256)*2		0.078 (20 μm/256)*2	0.016 (4 μm/256)*2
		0.0049 (20 μm/4096) *3			0.00098 (4 μm/4096) *3		0.0049 (20 μm/4096) *3	0.00098 (4 μm/4096) *3
Movable Member Mass	kg	0.1	0.1	0.215	0.215	0.19	0.19	
Total Mass (excluding cables)	kg	0.35	0.31	0.62	0.62	0.63	0.63	
Repeatability*4	μm	±0.5	±0.5	±0.5	±0.5	±0.5	±0.5	

*1: Values obtained when the acceleration is 4.9 m/s².

*2: The value applies when serial converter unit JZDP-D00□-□□□-E is used.

*3: The value applies when serial converter unit JZDP-G00□-□□□-E is used.

*4: Values obtained when the ambient temperature is constant.

● Performance Curves

● Force - Speed

● Effective Force - Ambient Temperature

● Load Mass - Acceleration

A: Continuous Duty Zone

B: Intermittent Duty Zone (Note)

When the sensor temperature is 50 °C or less.

— Ambient temperature

(1) SGTMM01

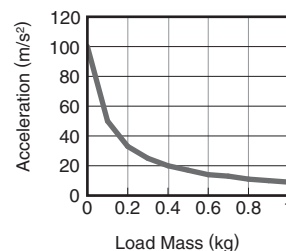
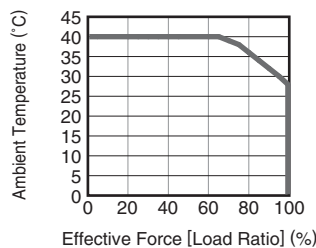
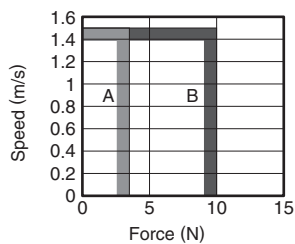

(2) SGTMM03-025

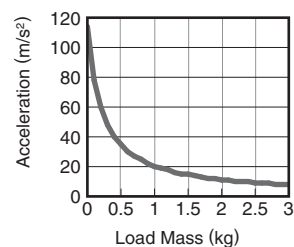
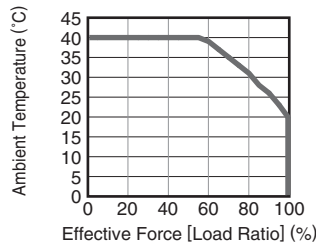
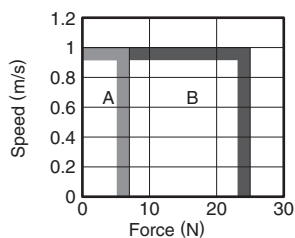

(3) SGTMM03-065

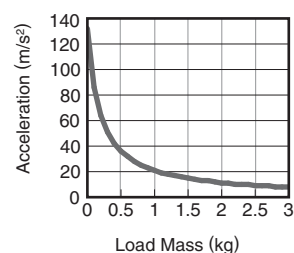
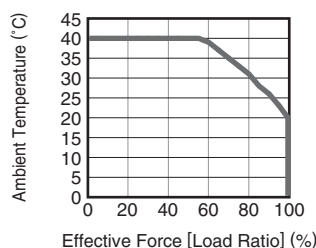
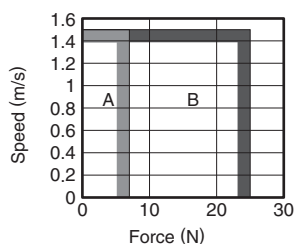

Note: When the effective force during intermittent duty is within the rated force, the servomotor can be used within the intermittent duty zone.

SGTMM Linear Sliders Units: mm

● External Dimensions

(1) SGTMM01

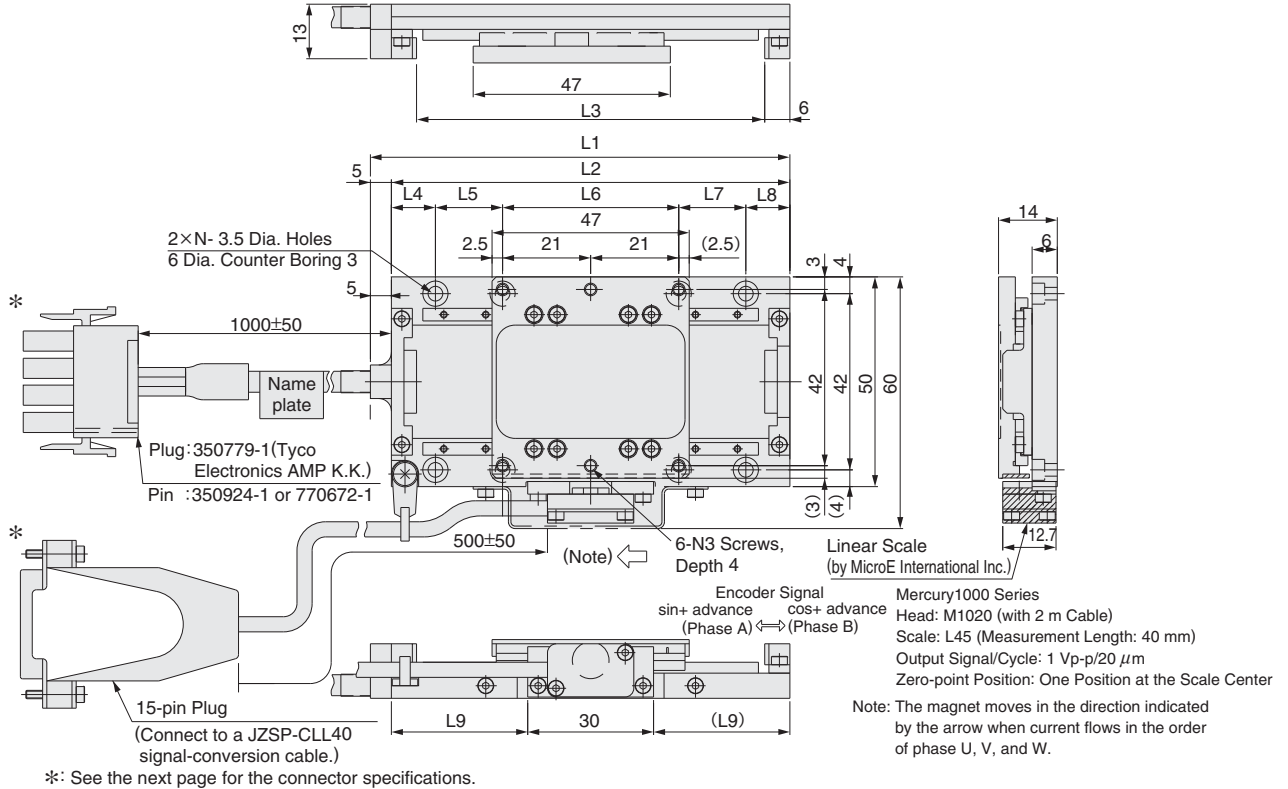

Linear Slider Model	L1	L2	L3	L4	L5	L6	L7	L8	L9	N
SGTMM01-	mm	mm	mm	mm	mm	mm	mm	mm	mm	
010AM20A	80	75	63	14	42	8	—	11	22.5	3
030AM20A	100	95	83	10.5	16	42	16	10.5	32.5	4

(2) SGTMM03-025AH20AP

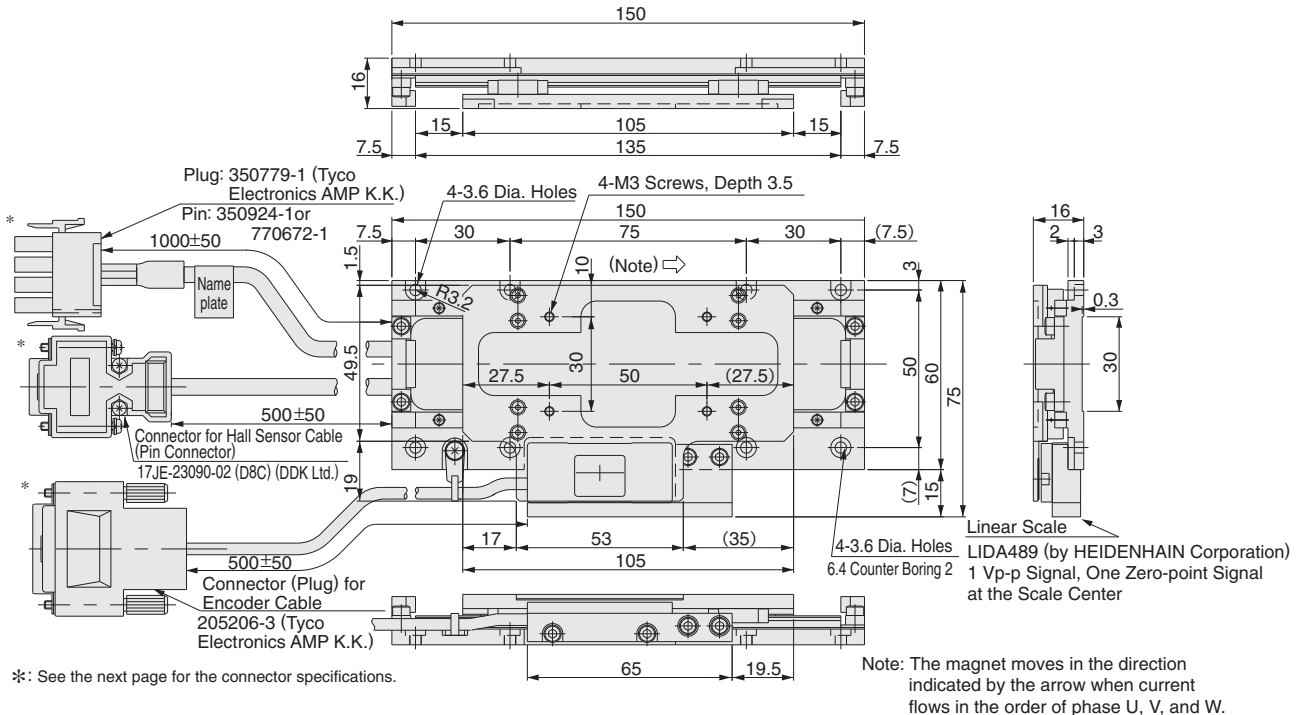

SGTMM Linear Sliders Units: mm

External Dimensions

(3) SGTMM03-025AH04AP

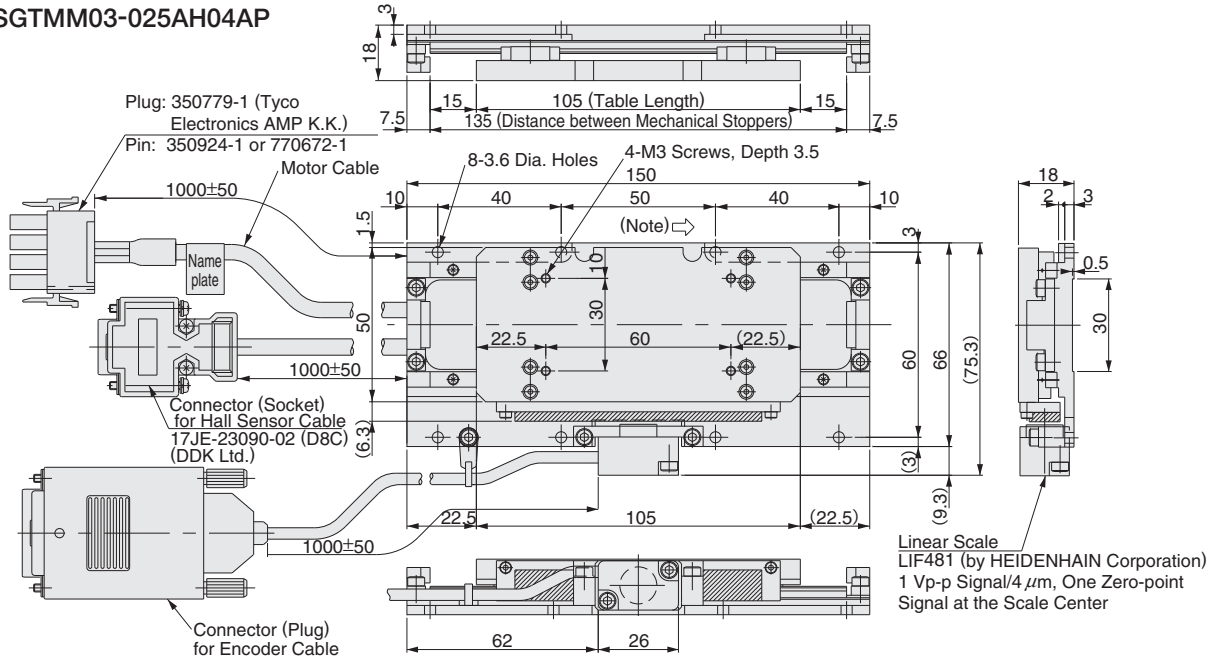

Note: The magnet moves in the direction indicated by the arrow when current flows in the order of phase U, V, and W.

(4) SGTMM03-065AH20A

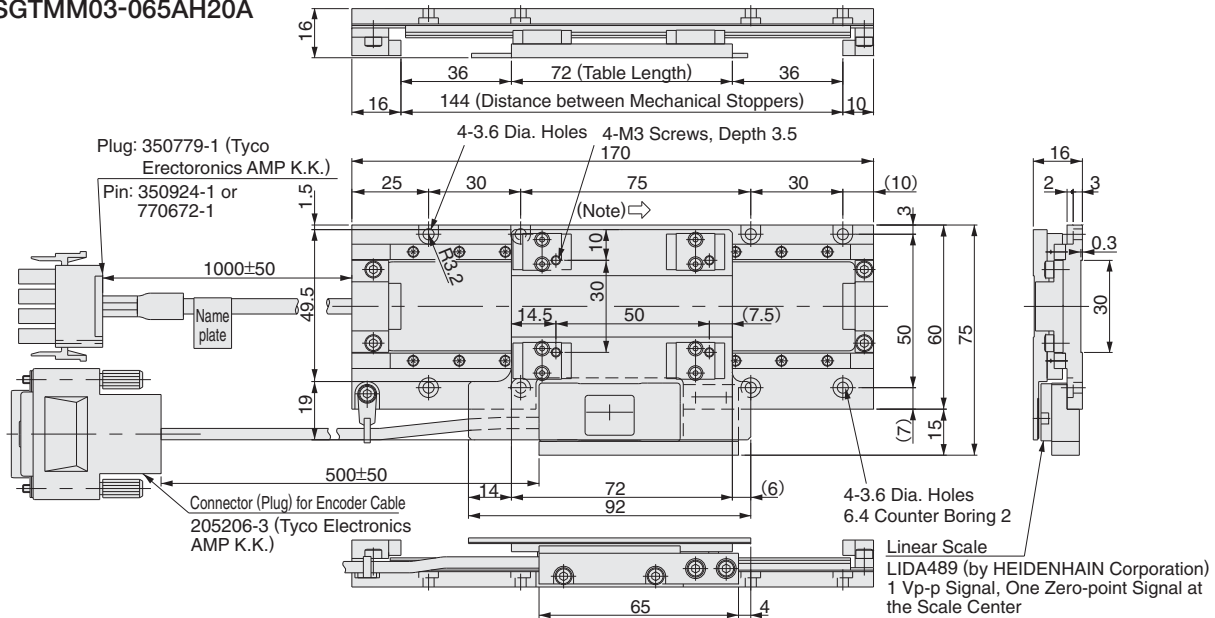

Note: The magnet moves in the direction indicated by the arrow when current flows in the order of phase U, V, and W.

Connector Specifications for the Σ-Trac-μ Series of Linear Sliders (All Models)

For SGTMM01 Linear Sliders

Pin No.	Name	Lead Color
1	Phase U	Red
2	Phase V	White
3	Phase W	Blue
4	FG	Green

Pin No.	Signal	Pin No.	Signal
1	IW-	9	N/C
2	IW+	10	N/C
3	Test	11	N/C
4	Transmit	12	+5 V
5	Receive	13	GND
6	Reset	14	Cos-
7	Cos+	15	Sin-
8	Sin+		

For SGTMM03 Linear Sliders

Pin No.	Name	Lead Color
1	Phase U	Red
2	Phase V	White
3	Phase W	Blue
4	FG	Green

Pin No.	Signal	Pin No.	Signal
1	Cos output (A+)	9	/Cos output (A-)
2	0 V	10	0 V sensor
3	Sin output (B+)	11	/Sin output (B-)
4	+5 V	12	5 V sensor
5	Not used	13	Not used
6	Not used	14	/Ref (R+)
7	/Ref (R-)	15	Not used
8	Not used	Case	Shield

Pin No.	Signal
1	+5V (power supply)
2	Phase-U output
3	Phase-V output
4	Phase-W output
5	0V (power supply)
6	Not used
7	Not used
8	Not used
9	Not used

SGTMM Linear Sliders Units: mm

● External Dimensions
(5) SGTMM03-065AH20AP

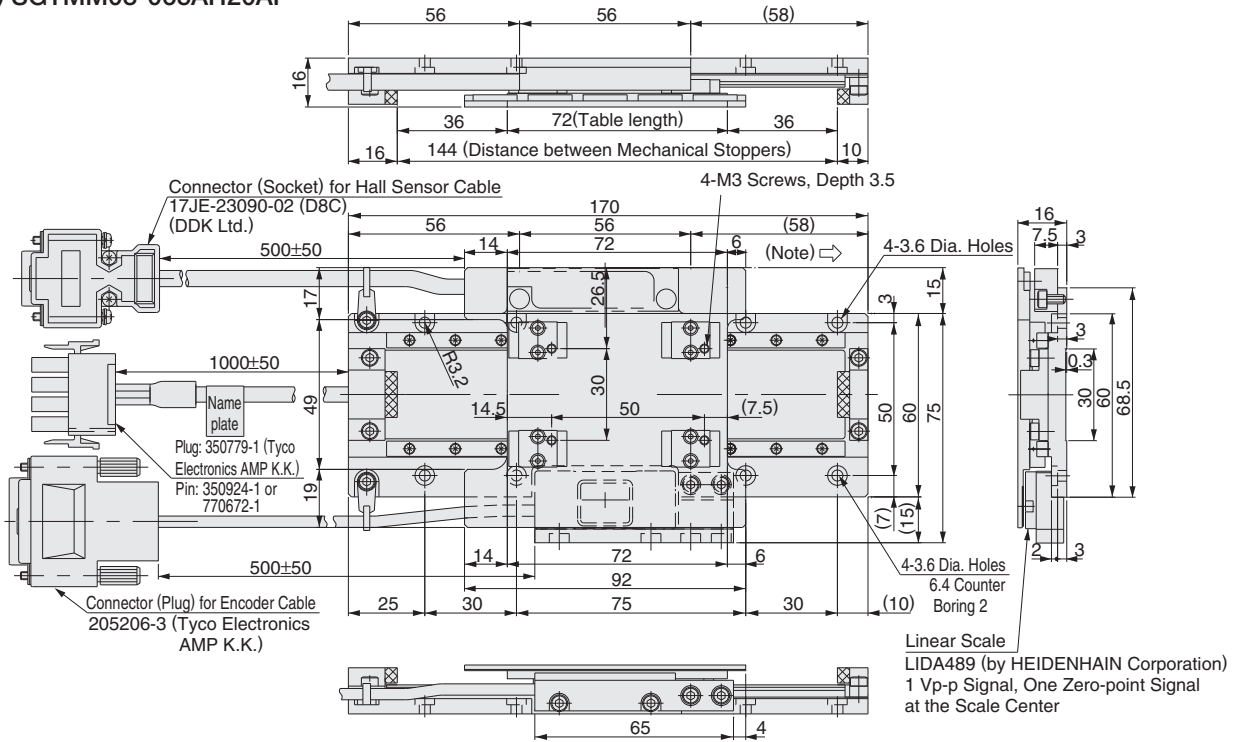

Note: The magnet moves in the direction indicated by the arrow when current flows in the order of phase U, V, and W.

(6) SGTMM03-065AH04AP

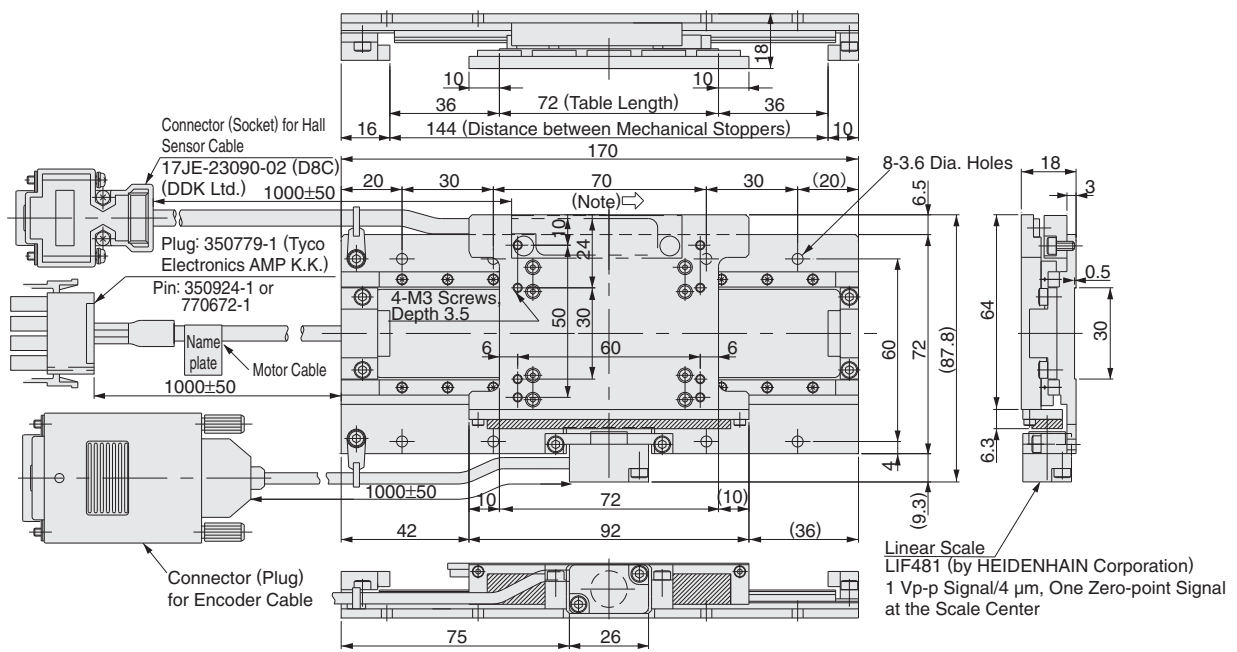

Note: The magnet moves in the direction indicated by the arrow when current flows in the order of phase U, V, and W.

Linear Sliders

Selecting Cables and Connectors

● Connection diagrams

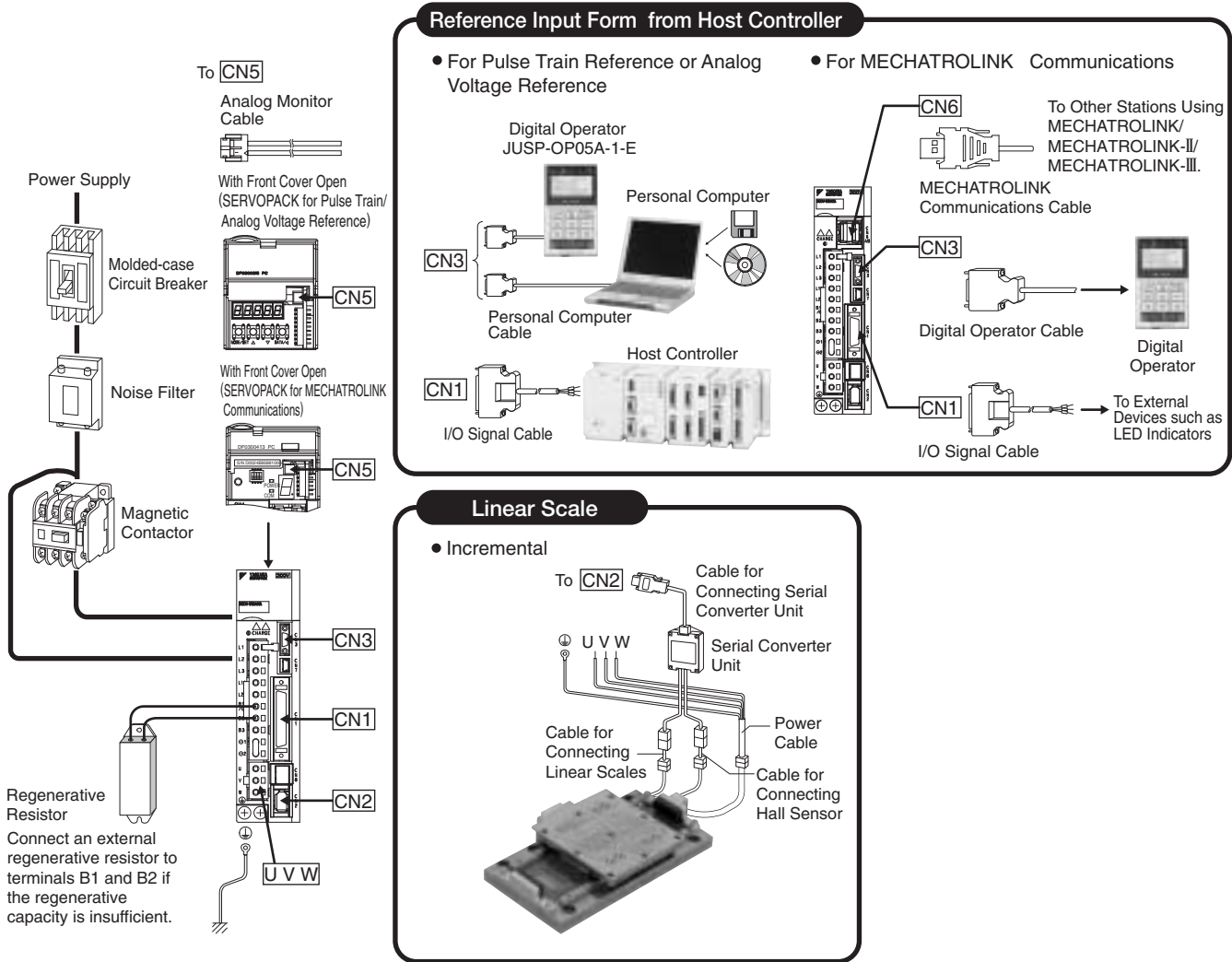

● Applicable Cables and Connectors

Motor Type	Linear Scale Type	Servo Drive		Motor Cable	Serial Converter Unit Model JZDP-	Linear Scale Connection Cables		
		SERVOPACK Model SGD-V	SERVOPACK++ Motor	[CN2]++Serial Converter Unit		Serial Converter Unit++Linear Scale		
	Σ -Trac- μ Series Model	Single-phase 100 V	Three-phase 200 V	Power Cable (Flexible Type)		Cable for Connecting Serial Converter Unit (Flexible Type)	Cable for Connecting Linear Scales (Flexible Type)	
Moving Magnet (MM)	Incremental	SGTMM01-010AM20A	R70F	R70A	JZSP-CLN11-□□-E	□003-242-E	JZSP-CLP70-□□-E The numbers in the boxes (□□) indicate the cable length. 01 = 1 m 03 = 3 m 05 = 5 m 10 = 10 m 15 = 15 m 20 = 20 m	JZSP-CLL00-□□-E*1 The numbers in the boxes (□□) indicate the cable length. 01 = 1 m 03 = 3 m 05 = 5 m 10 = 10 m 15 = 15 m Note: For SGTMM01 linear sliders, a JZSP-CLL40-E cable (length: 0.2 m) is also required.
		SGTMM01-030AM20A	R70F	R70A	JZSP-CLN11-□□-E	□003-242-E		
		SGTMM03-025AH20AP	R90F	R90A	JZSP-CLN11-□□-E	□006-221-E		
		SGTMM03-025AH04AP	R90F	R90A	JZSP-CLN11-□□-E	□006-221-E		
		SGTMM03-065AH20A	R90F	R90A	JZSP-CLN11-□□-E	□003-220-E		
		SGTMM03-065AH20AP	R90F	R90A	JZSP-CLN11-□□-E	□006-220-E		
		SGTMM03-065AH04AP	R90F	R90A	JZSP-CLN11-□□-E	□006-220-E		

Selecting Cables and Connectors

● Detail Drawings: Serial Converter Units for Linear Scales by HEIDENHAIN Corporation

● JZDP-□006-□□□-E
(With Hall Sensor Cable)

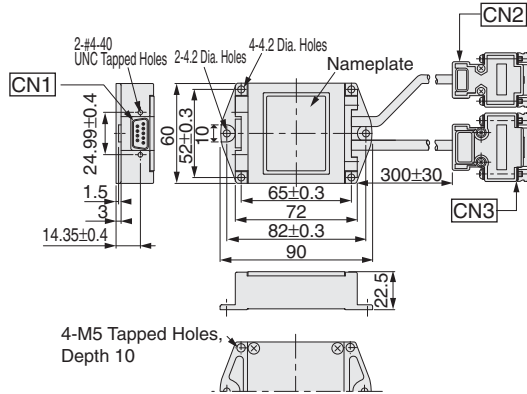

● JZDP-□003-□□□-E
(Without Hall Sensor Cable)

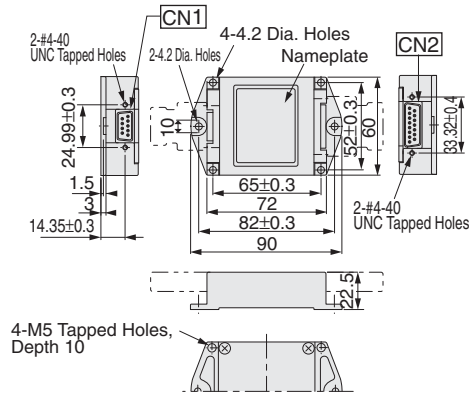

● Details on Connectors

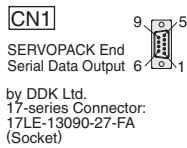

Pin No.	Signal	Pin No.	Signal
1	+5V	6	Phase/S output
2	Phase-S output	7	Not used
3	Not used	8	Not used
4	Not used	9	Not used
5	0V	Case	Shield

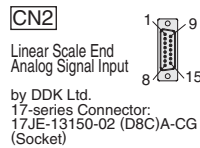

Pin No.	Signal	Pin No.	Signal
1	cos input (A+)	9	/cos input (A-)
2	0V	10	0 V sensor
3	sin input (B+)	11	/sin input (B-)
4	+5V	12	5 V sensor
5	Not used	13	Not used
6	Not used	14	Ref input (R+)
7	/Ref input (R-)	15	Not used
8	Not used	Case	Shield

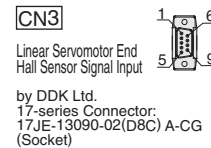

Pin No.	Signal	Pin No.	Signal
1	+5V	6	Not used
2	Phase-U input	7	Not used
3	Phase-V input	8	Not used
4	Phase-W input	9	Not used
5	0V	Case	Shield

Serial Converter Unit → Hall Sensor	Pulse Train or Analog Voltage Reference		MECHATROLINK Communications		Cables for Setting Devices/Monitors	
	I/O Signal Connector [CN1]	I/O Signal Connector [CN1]	MECHATROLINK-II Communications Connector [CN6A] or [CN6B]	MECHATROLINK-III Communications Cable [CN6A] or [CN6B]	[CN5]	
Cable for Connecting Hall Sensor (Flexible Type)	Connector Terminal Block Converter Unit	Cable with Loose Wires at One End	Connector Terminal Block Converter Cable		Analog Monitor Cable	
JZSP-CLL10-□□-E The numbers in the boxes (□□) indicate the cable length. 01 = 1 m 03 = 3 m 05 = 5 m 10 = 10 m 15 = 15 m	JZSP-TA50PG-E (with a 0.5 m cable)	JZSP-CSI01-□-E*2 The number in the box (□) indicates the cable length. 1 = 1 m 2 = 2 m 3 = 3 m	JZSP-TA26P-□-E*2 □ → None = 0.5 m 1 = 1 m 2 = 2 m	MECHATROLINK communications cable: JEPMC-W6002-□□□-E The numbers in the boxes (□□□) indicate the cable length. A5 = 0.5 m 20 = 20 m 01 = 1 m 30 = 30 m 03 = 3 m 40 = 40 m 05 = 5 m 50 = 50 m 10 = 10 m MECHATROLINK terminator: JEPMC-W6022-E	The numbers in the boxes (□□) indicate the cable length. JEPMC-W6012-□□□-E A2 = 0.2 m 05 = 5 m A5 = 0.5 m 10 = 10 m 01 = 1 m 20 = 20 m 02 = 2 m 30 = 30 m 03 = 3 m 50 = 50 m 04 = 4 m JEPMC-6013-□□□-E*3 10 = 10 m 50 = 50 m 20 = 20 m 75 = 75 m 30 = 30 m JEPMC-6014-□□□-E A5 = 0.5 m 10 = 10 m 01 = 1 m 30 = 30 m 03 = 3 m 50 = 50 m 05 = 5 m	JZSP-CA01-E (1m)

*1: When using serial converter unit JZDP-G00□-□□□-E, the maximum cable length should be 3 m.
*2: A connector kit is required to assemble the cable. For details, refer to *SERVOPACKs* in this catalog.
*3: Currently in pre-release. Will be available soon.

Linear Sliders

Σ -Trac-MAG

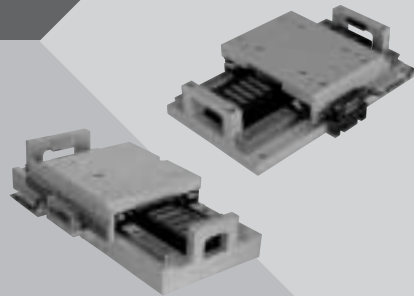

Model Designations

• With Incremental Linear Scales

SGT M F4 A - 027 A H 20 A

<p>Σ-Trac Series</p> <p>Linear Slider</p> <p>Moving Magnet Type</p> <p>Armature Code (Armature not integrally mounted)</p> <p>F4 : SGLFW-35A230A-F F5 : SGLFW-50A380A-F</p> <p>Table Length</p> <p>A : Short B : Long</p>	<p>Design Revision Order A, B, C</p> <p>Linear Scale Resolution 20 : 20 μm</p> <p>Linear Scale Manufacturer H : HEIDENHAIN Corporation</p> <p>Linear Scale Output Form A : Analog output 1 Vp-p</p> <p>Peak Force</p> <p>027 : 270 N 036 : 360 N 054 : 540 N 072 : 720 N</p>
---	---

Armature Code	Table Length	Effective Stroke	Armature Code	Table Length	Effective Stroke
F4	A	100 mm	F5	A	185 mm
	B	65 mm		B	110 mm

• With Absolute (ABS) Linear Scales

SGT M F4 A - 027 ABS 1 A

<p>Σ-Trac Series</p> <p>Linear Slider</p> <p>Moving Magnet Type</p> <p>Armature Code (Armature not integrally mounted)</p> <p>F4 : SGLFW-35A230A-F F5 : SGLFW-50A380A-F</p> <p>Table Length</p> <p>A : Short B : Long</p>	<p>Design Revision Order A, B, C</p> <p>Linear Scale Specifications</p> <p>1 : ST781A (by Mitutoyo Corporation, resolution: 0.5 μm) 2 : ST783A (by Mitutoyo Corporation, resolution: 0.1 μm)</p> <p>With an absolute linear scale</p> <p>Peak Force</p> <p>027 : 270 N 036 : 360 N 054 : 540 N 072 : 720 N</p>
---	--

Armature Code	Table Length	Effective Stroke	Armature Code	Table Length	Effective Stroke
F4	A	100 mm	F5	A	185 mm
	B	65 mm		B	110 mm

Features

- Optimum drive for high-acceleration and high-tact operations because of its lightweight moving member.
- For short strokes (65 mm to 185 mm)
- Cooling units (pipes, etc.) for forced-air or liquid cooling systems can be placed on the fixed side.
- Linear scale options: Incremental or absolute.
- Improved stroke efficiency*

*:Ratio of effective stroke to the total length of drive system

Model Classification

● Force

SERVOPACK Model SGD V-		Σ-Trac-MAG Series Linear Sliders						
Single-phase 100 VAC	Three-phase 200 VAC	Model	Force	200 N	400 N	600 N	800 N	1000 N
2R1F	1R6A	SGTMF4A-027						
2R1F	1R6A	SGTMF4B-036						
-	5R5A	SGTMF5A-054						
-	5R5A	SGTMF5B-072						

● Stroke Length

Model	Stroke Length	50 mm	100 mm	150 mm	200 mm
SGTMF4A-027			● 100 mm		
SGTMF4B-036		● 65 mm			
SGTMF5A-054					● 185 mm
SGTMF5B-072			● 110 mm		

SGTMF4 Linear Sliders

● Ratings and Specifications

Time Rating: Continuous

Insulation Resistance: 500 VDC, 10 MΩ min.

Ambient Temperature: 0°C to 40°C

Excitation: Permanent magnet

Dielectric Strength: 1500 VAC for one minute

Protection Methods: Self-cooled

Ambient Humidity: 20% to 80% (no condensation)

Allowable Winding Temperature: 130°C (Thermal class B)

Linear Slider Model	With Incremental Linear Scales		With Absolute Linear Scales	
	SGTMF4A-027AH20A	SGTMF4B-036AH20A	SGTMF4A-027ABS1A	SGTMF4B-036ABS1A
Applicable SERVOPACK Model	SGDV-2R1F, 1R6A		2R1F, 1R6A	
Applicable Serial Converter Unit Model	JZDP-□003-243-E	□003-244-E	—	—
Rated Force	N	90	120	90
Peak Force	N	270	360	270
Force Constant	N/Arms	66.9	89.2	66.9
Motor Constant	N/√W	11	14.6	11
Maximum Payload*1	kg	40	55	40
Effective Stroke	mm	100	65	100
Resolution	μm	Incremental linear scale: 0.078 (20 μm/256)		Absolute linear scale*3: 0.5
Movable Member Mass	kg	1.72	2.52	1.72
Total Mass (excluding cables)	kg	6.8	8.05	6.8
Repeatability*2	μm	±1.0	±1.0	±1.0

*1: Values obtained when the acceleration is 4.9 m/s².

*2: Values obtained when the ambient temperature is constant.

*3: An absolute linear scale with a resolution of 0.1 μm is also available. Contact your Yaskawa representative for details.

● Performance Curves

● Force - Speed

● Effective Force - Ambient Temperature

● Load Mass - Acceleration

A: Continuous Duty Zone

B: Intermittent Duty Zone (Note)

When the sensor temperature is 50 °C or less

— Ambient temperature

(1) SGTMF4A-027

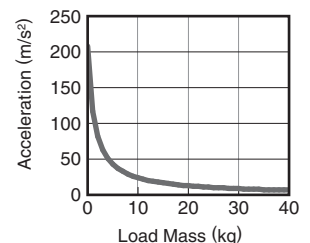
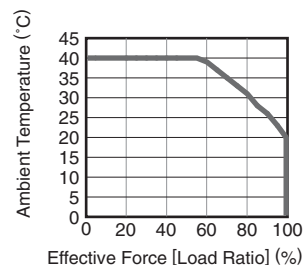
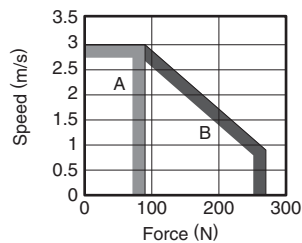

(2) SGTMF4B-036

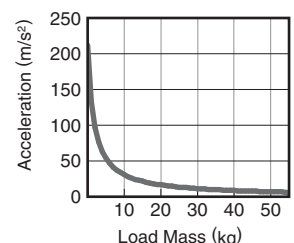
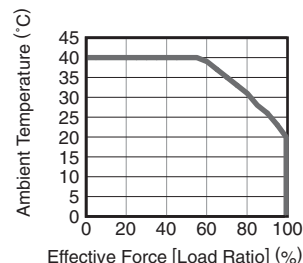
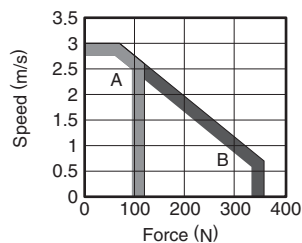

Note: When the effective force during intermittent duty is within the rated force, the servomotor can be used within the intermittent duty zone.

SGTMF4 Linear Sliders Units: mm

● External Dimensions

● With Incremental Linear Scale

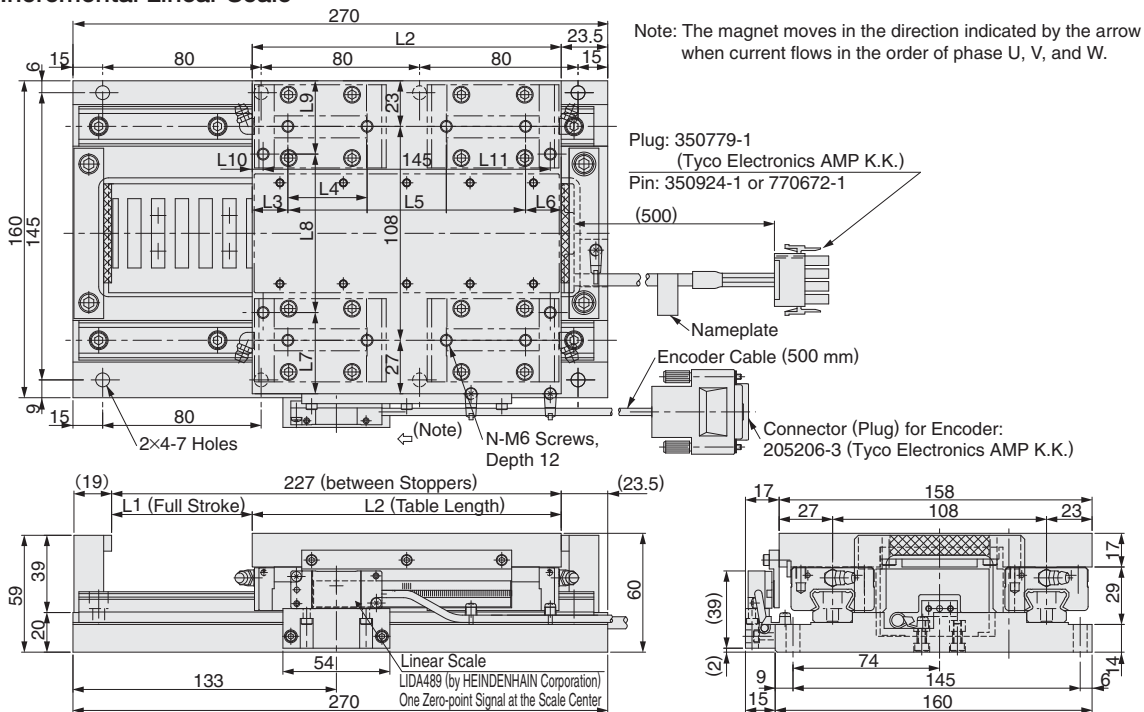

Linear Slider Model SGTMF	L1 mm	L2 mm	L3 mm	L4 mm	L5 mm	L6 mm	L7 mm	L8 mm	L9 mm	L10 mm	L11 mm	N
4A-027AH20A	107	120	20	40	80	20	—	—	—	—	—	6
4B-036AH20A	71	156	18	40	120	18	41	80	37	5.5	145	12

● With Absolute Linear Scale

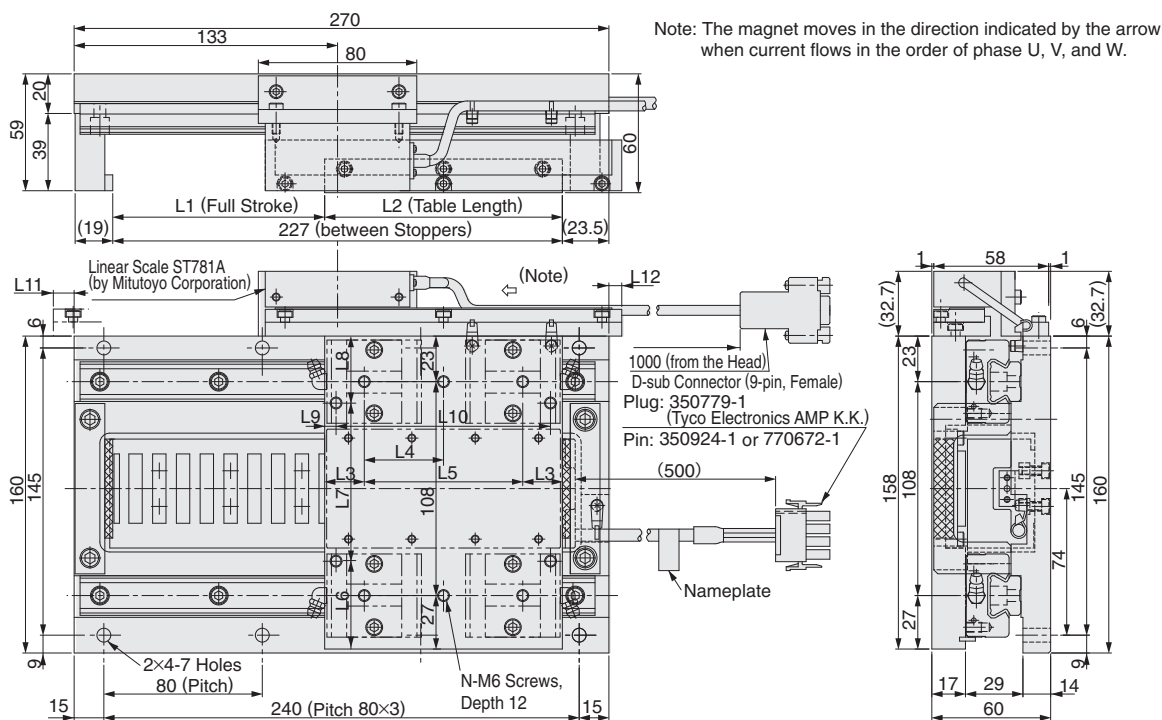

Linear Slider Model SGTMF	L1 mm	L2 mm	L3 mm	L4 mm	L5 mm	L6 mm	L7 mm	L8 mm	L9 mm	L10 mm	L11 mm	L12 mm	N
4A-027ABS1A	107	120	20	40	80	—	—	—	—	—	10.5	6.5	6
4B-036ABS1A	71	156	18	40	120	41	80	37	5.5	145	—	—	12

Linear Sliders

SGTMF5 Linear Sliders

● Ratings and Specifications

Time Rating: Continuous

Insulation Resistance: 500 VDC, 10 MΩ min.

Ambient Temperature: 0°C to 40°C

Excitation: Permanent magnet

Dielectric Strength: 1500 VAC for one minute

Protection Methods: Self-cooled

Ambient Humidity: 20% to 80% (no condensation)

Allowable Winding Temperature: 130°C (Thermal class B)

Linear Slider Model		With Incremental Linear Scales		With Absolute Linear Scales	
		SGTMF5A-054AH20A	SGTMF5B-072AH20A	SGTMF5A-054ABS1A	SGTMF5B-072ABS1A
Applicable SERVOPACK Model	SGDV-	5R5A	5R5A	5R5A	5R5A
Applicable Serial Converter Unit Model	JZDP-	□003-245-E	□003-246-E	—	—
Rated Force	N	150	200	150	200
Peak Force	N	540	720	540	720
Force Constant	N/Arms	59.4	79.1	59.4	79.1
Motor Constant	N/√W	18.5	24.7	18.5	24.7
Maximum Payload*1	kg	85	110	85	110
Effective Stroke	mm	185	110	185	110
Resolution	μm	Incremental linear scale: 0.078 (20 μm/256)		Absolute linear scale*3: 0.5	
Movable Member Mass	kg	4.2	6.84	4.2	6.84
Total Mass (excluding cables)	kg	19.8	22.5	19.8	22.5
Repeatability*2	μm	±1.0	±1.0	±1.0	±1.0

*1: Values obtained when the acceleration is 4.9 m/s².

*2: Values obtained when the ambient temperature is constant.

*3: An absolute linear scale with a resolution of 0.1 μm is also available. Contact your Yaskawa representative for details.

● Performance Curves

● Force - Speed

A: Continuous Duty Zone
B: Intermittent Duty Zone (Note)

(1) SGTMF5A-054

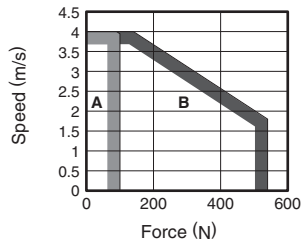

(2) SGTMF5B-072

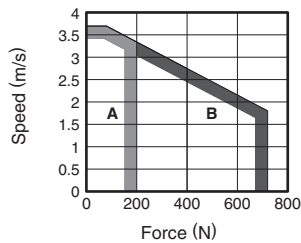

Note: When the effective force during intermittent duty is within the rated force, the servomotor can be used within the intermittent duty zone.

● Effective Force - Ambient Temperature

When the sensor temperature is 50 °C or less
 — Ambient temperature

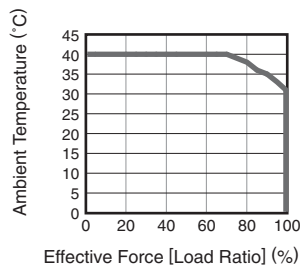
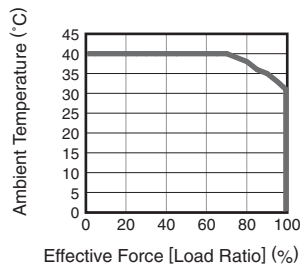

● Load Mass - Acceleration

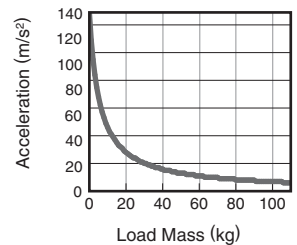
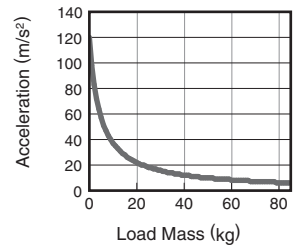

SGTMF5 Linear Sliders Units: mm

● External Dimensions

● With Incremental Linear Scale

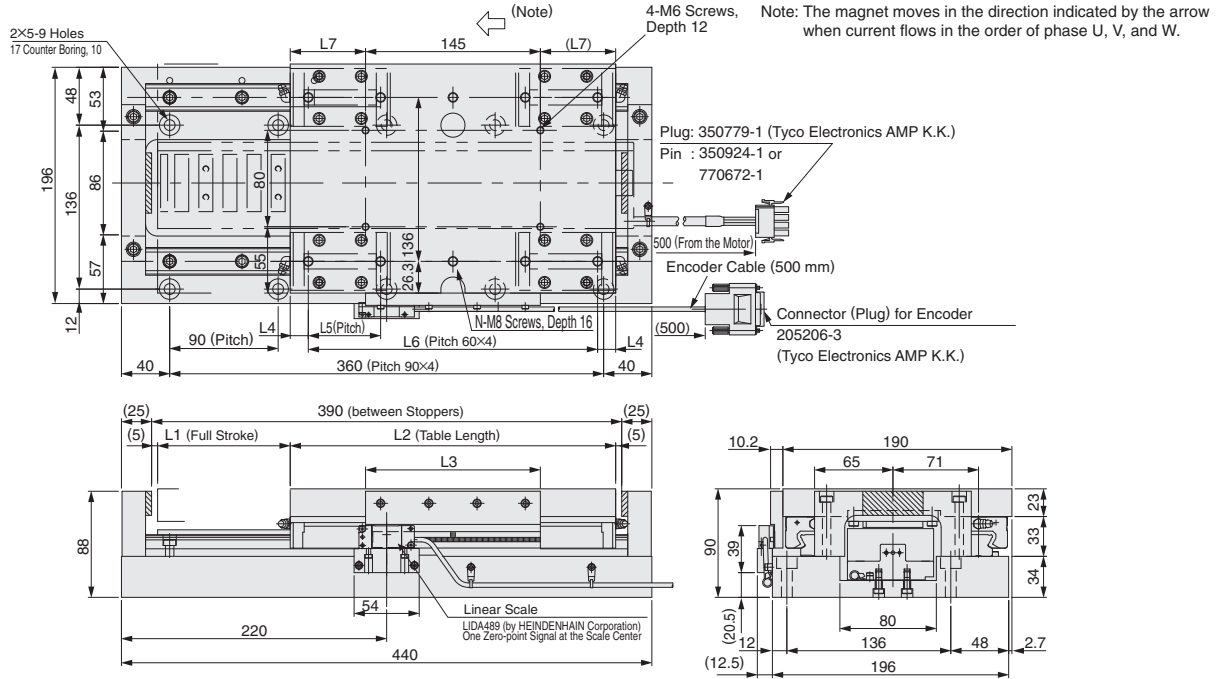

Linear Slider Model SGTMF	L1 mm	L2 mm	L3 mm	L4 mm	L5 mm	L6 mm	L7 mm	N
5A-054AH20A	185	195	220	37.5	60	120	25	6
5B-072AH20A	110	270	145	15	60	240	62.5	10

● With Absolute Linear Scale

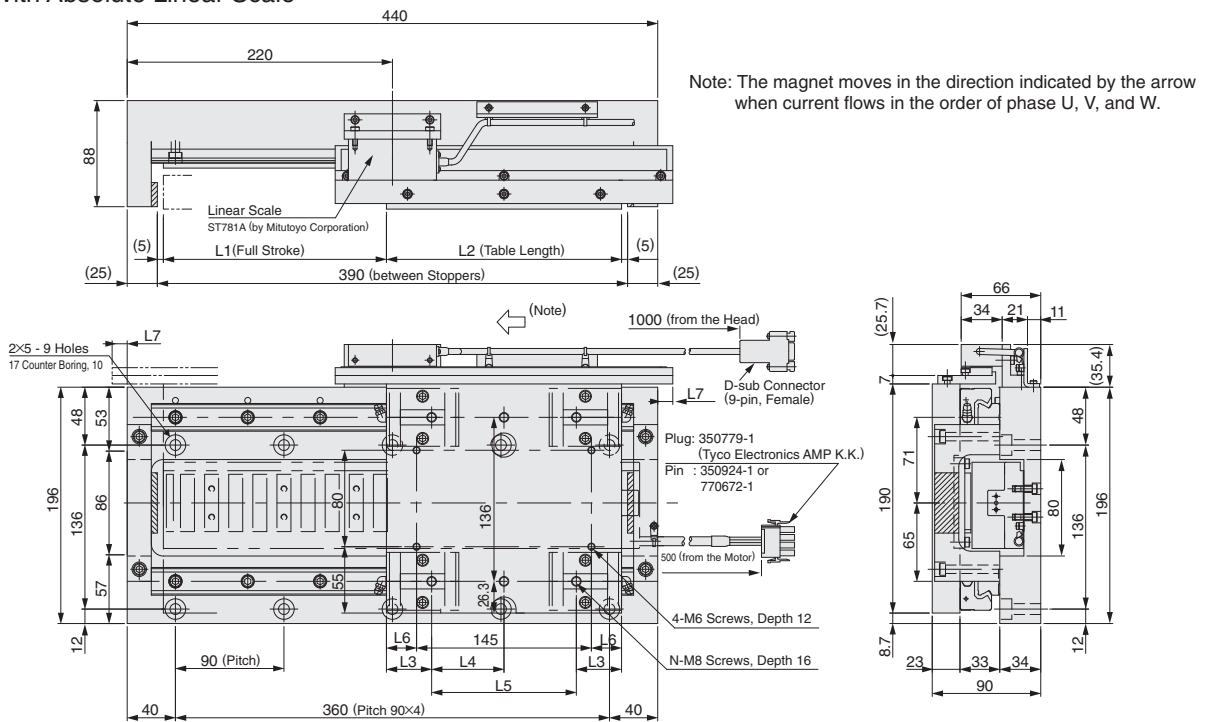

Linear Slider Model SGTMF	L1 mm	L2 mm	L3 mm	L4 mm	L5 mm	L6 mm	L7 mm	N
5A-054ABS1A	185	195	37.5	60	120	25	12.5	6
5B-072ABS1A	110	270	15	60	240	62.5	—	10

Selecting Cables and Connectors

● Connection diagrams

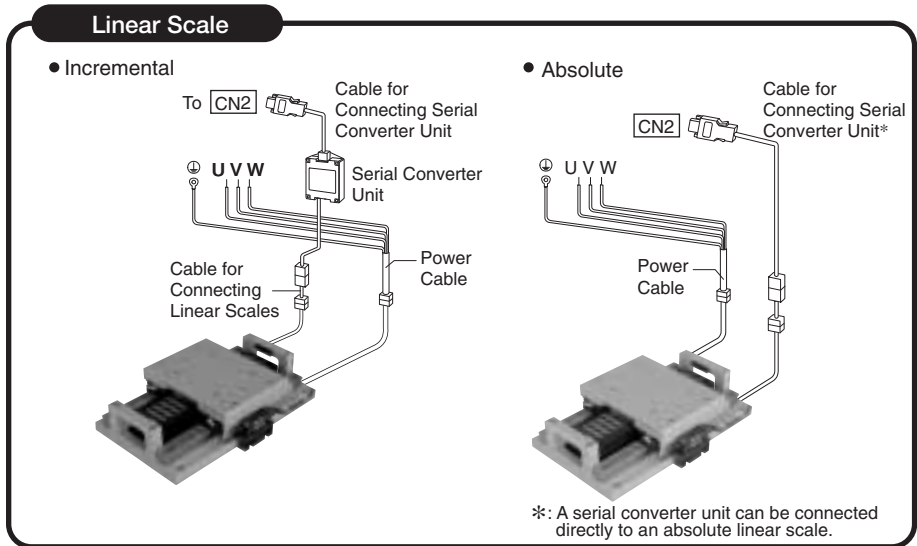
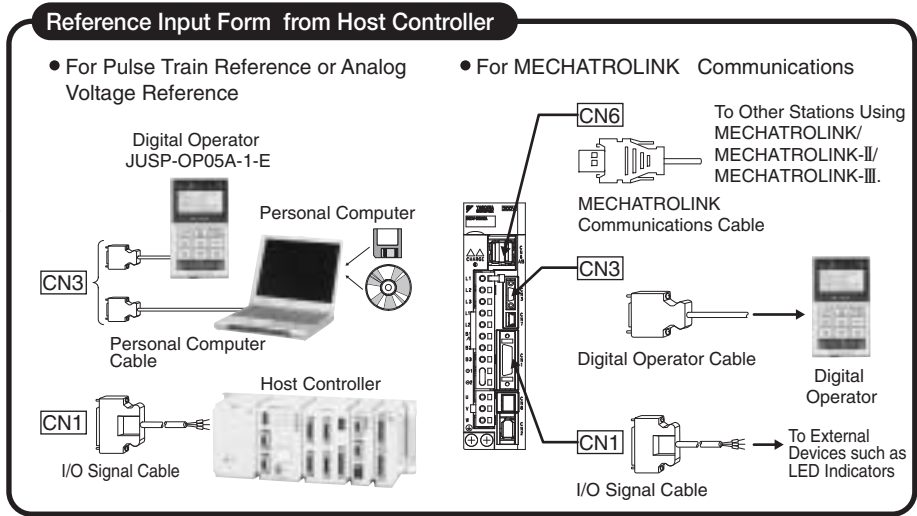
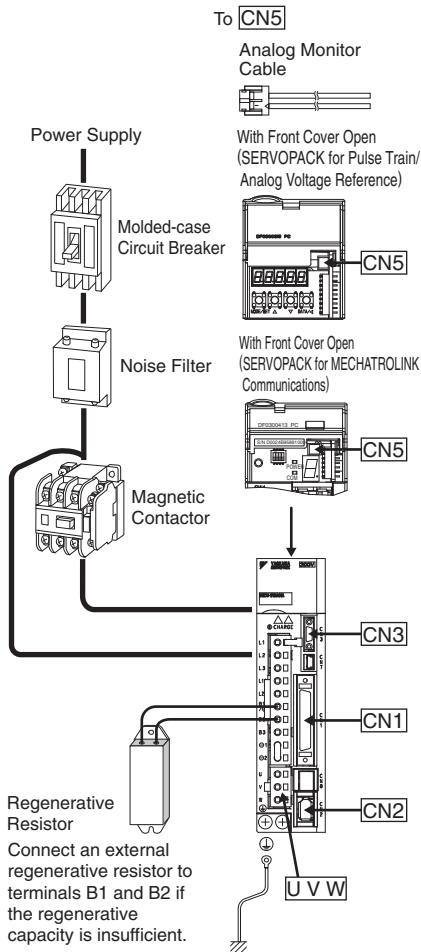

● Applicable Cables and Connectors

Motor Type	Linear Scale Type	Servo Drive		Motor Cable	Serial Converter Unit Model JZDP-	Linear Scale Connection Cables		
		SERVOPACK Model SGD-V	SERVOPACK ++ Motor	Power Cable (Flexible Type)		[CN2] ↔ Serial Converter Unit	Serial Converter Unit ↔ linear scale	
	Σ-Trac-MAG Series Model	Single-phase 100 V	Three-phase 200 V			Cable for Connecting Serial Converter Unit (Flexible Type)	Cable for Connecting Linear Scales (Flexible Type)	
Moving Magnet (MM)	Incremental	SGTMF4A-027AH20A	2R1F	1R6A	JZSP-CLN11-□□-E	□003-243-E	JZSP-CLP70-□□-E [The numbers in the boxes(□□) indicate the cable length. 01 = 1 m 03 = 3 m 05 = 5 m 10 = 10 m 15 = 15 m 20 = 20 m	JZSP-CLL00-□□-E*1 [The numbers in the boxes(□□) indicate the cable length. 01 = 1 m 03 = 3 m 05 = 5 m 10 = 10 m 15 = 15 m
		SGTMF4B-036AH20A	2R1F	1R6A	JZSP-CLN11-□□-E	□003-244-E		
		SGTMF5A-054AH20A	—	5R5A	JZSP-CLN21-□□-E	□003-245-E		
		SGTMF5B-072AH20A	—	5R5A	JZSP-CLN21-□□-E	□003-246-E		
	Absolute	SGTMF4A-027ABS1A	2R1F	1R6A	JZSP-CLN11-□□-E	—	JZSP-CLP70□□-E [CN2] ↔ Linear Scale	—
		SGTMF4B-036ABS1A	2R1F	1R6A	JZSP-CLN11-□□-E	—		
		SGTMF5A-054ABS1A	—	5R5A	JZSP-CLN21-□□-E	—		
		SGTMF5B-072ABS1A	—	5R5A	JZSP-CLN21-□□-E	—		

Selecting Cables and Connectors

● **Detail Drawings: Serial Converter Units for Linear Scales by HEIDENHAIN Corporation**

● **JZDP-□□06-□□□□-E**
(With Hall Sensor Cable)

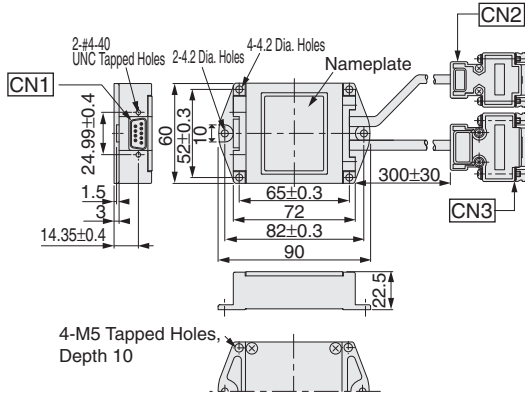

● **JZDP-□□003-□□□□-E**
(Without Hall Sensor Cable)

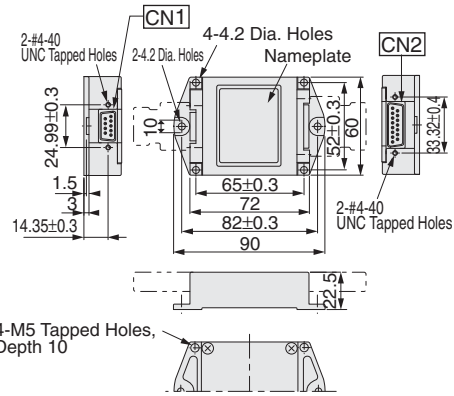

● **Details on Connectors**

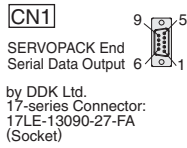

Pin No.	Signal	Pin No.	Signal
1	+5V	6	Phase/S output
2	Phase-S output	7	Not used
3	Not used	8	Not used
4	Not used	9	Not used
5	0V	Case	Shield

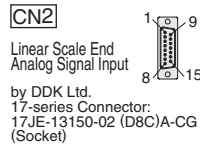

Pin No.	Signal	Pin No.	Signal
1	cos input (A+)	9	/cos input (A-)
2	0V	10	0 V sensor
3	sin input (B+)	11	/sin input (B-)
4	+5V	12	5 V sensor
5	Not used	13	Not used
6	Not used	14	Ref input (R+)
7	/Ref input (R-)	15	Not used
8	Not used	Case	Shield

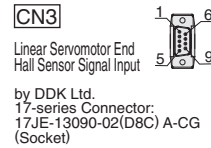

Pin No.	Signal	Pin No.	Signal
1	+5V	6	Not used
2	Phase-U input	7	Not used
3	Phase-V input	8	Not used
4	Phase-W input	9	Not used
5	0V	Case	Shield

Pulse Train or Analog Voltage Reference	MECHATROLINK Communications				Cables for Setting Devices/Monitors	
	I/O Signal Connector [CN1]		I/O Signal Connector [CN1]	MECHATROLINK-II Communications Connector [CN6A] or [CN6B]		MECHATROLINK-III Communications Cable [CN6A] or [CN6B]
	Connector Terminal Block Converter Unit	Cable with Loose Wires at One End	Connector Terminal Block Converter Cable			Analog Monitor Cable
	JZSP-TA50PG-E (with a 0.5 m cable)	JZSP-CSI01-□□-E*2 The number in the box (□) indicates the cable length. 1 = 1 m 2 = 2 m 3 = 3 m	JZSP-TA26P-□□-E*2 □ → None = 0.5 m 1 = 1 m 2 = 2 m	MECHATROLINK communications cable: JEPMC-W6002-□□□-E The numbers in the boxes (□□) indicate the cable length. A5 = 0.5 m 20 = 20 m 01 = 1 m 30 = 30 m 03 = 3 m 40 = 40 m 05 = 5 m 50 = 50 m 10 = 10 m	The numbers in the boxes (□□) indicate the cable length. JEPMC-W6012-□□□-E A2 = 0.2 m 05 = 5 m A5 = 0.5 m 10 = 10 m 01 = 1 m 20 = 20 m 02 = 2 m 30 = 30 m 03 = 3 m 50 = 50 m 04 = 4 m JEPMC-6013-□□□-E*3 10 = 10 m 50 = 50 m 20 = 20 m 75 = 75 m 30 = 30 m JEPMC-6014-□□□-E A5 = 0.5 m 10 = 10 m 01 = 1 m 30 = 30 m 03 = 3 m 50 = 50 m 05 = 5 m	JZSP-CA01-E (1 m)

*1: When using serial converter unit JZDP-G00□-□□□□-E, the maximum cable length should be 3 m.
*2: A connector kit is required to assemble the cable. For details, refer to *SERVOPACKs* in this catalog.
*3: Currently in pre-release. Will be available soon.

Analog Voltage/Pulse Train Reference Type SERVOPACKs

SGDV-□□□□01 (For Rotary Servomotors)

SGDV-□□□□05 (For Linear Servomotors)



Model Designations

SGDV - R70 A 01 A □

Σ-V Series
SGDV SERVOPACK

Options

Code	Specifications
Blank	Base-mounted (standard)
001000	Rack-mounted*

*: SGD-470A, -550A, -590A, -780A, -210D, -260D, -280D, -370D SERVOPACKs are duct-ventilated.

Design Revision Order

A, B...

Interface

Code	Specifications
F	100 VAC
A	200 VAC
D	400 VAC

Code	Specifications
01	Analog voltage/pulse train reference type (for rotary servomotors)
05	Analog voltage/pulse train reference type (for linear servomotors)

Current

Code	100 V		Code	200 V		Code	400 V	
	Applicable Servomotor Max. Capacity kW			Applicable Servomotor Max. Capacity kW			Applicable Servomotor Max. Capacity kW	
R70	0.05		R70	0.05		1R9	0.5	
R90	0.1		R90	0.1		3R5	1.0	
2R1	0.2		1R6	0.2		5R4	1.5	
2R8	0.4		2R8	0.4		8R4	2.0	
			3R8	0.5		120	3.0	
			5R5	0.75		170	5.0	
			7R6	1.0		210	6.0	
			120	1.5		260	7.5	
			180	2.0		280	11	
			200	3.0		370	15	
			330	5.0				
			470	6.0				
			550	7.5				
			590	11				
			780	15				

Features

- Unprecedented ease-of-use through cutting-edge technology
New tuning-less function means no adjustment needed.
Impressive load regulation with strengthened vibration suppression function.
- Slashed setup time
Setup wizard function and wiring conformation function of engineering tool SigmaWin+ allows easy setup just by watching the monitor.
- High response characteristics at 1 kHz min.
New advanced autotuning.
Reduced positioning time through model following control, and smooth machine control enabled by vibration suppression function.

Ratings

Single-phase 100 V

SERVOPACK Model	SGDV-□□□□	R70F	R90F	2R1F	2R8F
Applicable Servomotor Max. Capacity	kW	0.05	0.1	0.2	0.4
Continuous Output Current	Arms	0.66	0.91	2.1	2.8
Max. Output Current	Arms	2.1	2.9	6.5	9.3
Main Circuit	Single-phase 100 to 115 VAC+10% to -15% 50/60 Hz				
Control Circuit	Single-phase 100 to 115 VAC+10% to -15% 50/60 Hz				

Three-phase 200 V

SERVOPACK Model	SGDV-□□□□	R70A	R90A	1R6A	2R8A	3R8A	5R5A	7R6A	120A	180A	200A	330A	470A	550A	590A	780A
Applicable Servomotor Max. Capacity	kW	0.05	0.1	0.2	0.4	0.5	0.75	1.0	1.5	2.0	3.0	5.0	6	7.5	11	15
Continuous Output Current	Arms	0.66	0.91	1.6	2.8	3.8	5.5	7.6	11.6	18.5	19.6	32.9	46.9	54.7	58.6	78
Max. Output Current	Arms	2.1	2.9	5.8	9.3	11	16.9	17	28	42	56	84	110	130	140	170
Main Circuit	Three-phase 200 to 230 VAC+10% to -15% 50/60 Hz															
Control Circuit	Single-phase 200 to 230 VAC+10% to -15% 50/60 Hz															

Three-phase 400 V

SERVOPACK Model	SGDV-□□□□	1R9D	3R5D	5R4D	8R4D	120D	170D	210D	260D	280D	370D
Applicable Servomotor Max. Capacity	kW	0.5	1.0	1.5	2.0	3.0	5.0	6	7.5	11	15
Continuous Output Current	Arms	1.9	3.5	5.4	8.4	11.9	16.5	20.8	25.7	28.1	37.2
Max. Output Current	Arms	5.5	8.5	14	20	28	42	55	65	70	85
Main Circuit	Three-phase 380 to 480 VAC+10% to -15% 50/60 Hz										
Control Circuit	24 VDC ±15%										

●SERVOPACK Overload Characteristics

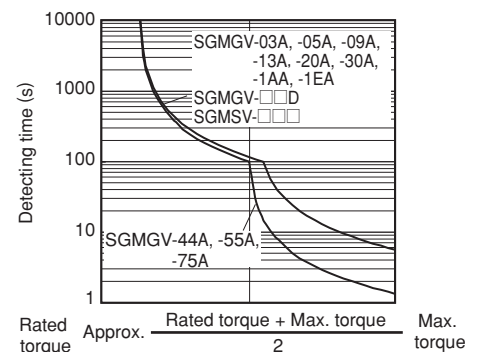
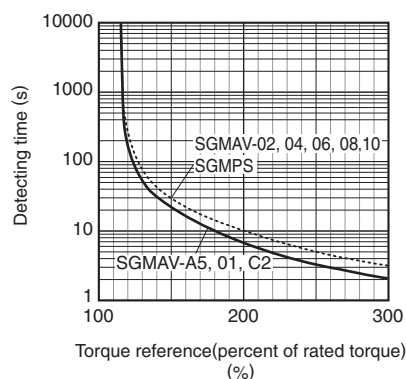
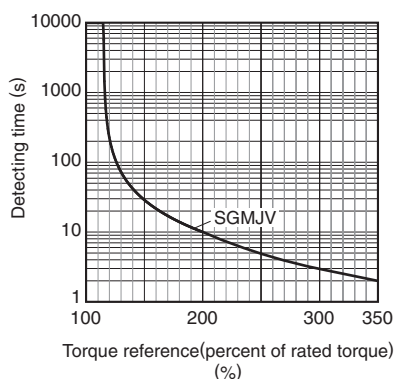

Note: Overload characteristics shown above do not guarantee continuous duty of 100% or more output. Use a servomotor with effective torque within the continuous duty zone of *Torque-Motor Speed Characteristics*.

Specifications

Items		Specifications	
Control Method		IGBT PWM control, sine-wave driven	
Feedback	Rotary Servomotors	Serial encoder: 13-bit (incremental encoder) : 17-bit (incremental/absolute encoder) : 20-bit (incremental/absolute encoder)	
	With Linear Servomotors	Serial converter unit or linear scale	
Operating Conditions	Surrounding Air/Storage Temperature	Surrounding air temperature: 0 to +55°C, Storage temperature: -20 to +85°C	
	Ambient/Storage Humidity	90%RH or less (no condensation)	
	Vibration/Shock Resistance	Vibration resistance: 4.9 m/s ² , Shock resistance: 19.6 m/s ²	
	Protection Class/Pollution Degree	Protection class: IP10, pollution degree: 2 Do not use SERVOPACKs in the following locations: · Locations subject to corrosive or flammable gasses · Locations subject to exposure to water, oil, or chemicals · Locations subject to dust, including iron dust, and salts	
	Others	Do not use SERVOPACKs in the following locations: · Locations subject to static electricity noise, strong electromagnetic/magnetic fields, radioactivity	
Altitude		1000 m or less	
Applicable Standards		UL508C EN50178, EN55011/A2 group1 classA, EN61000-6-2, EN61800-3, EN61800-5-1, EN954-1, IEC61508-1 to 4	
Configuration		Standard: Base-mounted Optional: Rack-mounted, Duct-ventilated	
Performance	Speed Control Range		
	Speed Regulation*1	Load Fluctuation	0% to 100% load: ±0.01% max. (at rated speed)
		Voltage Fluctuation	Rated voltage: ±10% : 0% (at rated speed)
		Temperature Fluctuation	25±25°C : ±0.1% max. (at rated speed)
	Torque Control Tolerance (Repeatability)		±1%
Soft Start Time Setting		0 to 10 s (can be set individually for acceleration and deceleration.)	
Communications	RS-422A Communications	Interface	Digital operator (JUSP-OP05A-1-E), personal computer (can be connected with SigmaWin+)
		1:N communications	RS-422A port: N= 15 max. available
		Axis address setting	Set by parameters
	USB Communications	Interface	Personal computer (can be connected with SigmaWin+.)
		Communications Standard	Compliant with USB1.1 standard (12 Mbps)
Display		CHARGE indicator	
Analog Monitor		Number of points: 2 Output voltage: ±10 VDC (linearity effective range ±8 V) Resolution: 16 bit Accuracy: ±20 mV (Typ) Max. output current: ±10 mA Settling time (±1%): 1.2 ms (Typ)	
Dynamic Brake (DB)		Activated when a servo alarm or overtravelling (OT) occurs, or when the power supply for the main circuit or servomotor is OFF.	
Protective Functions		Overcurrent, Overvoltage, low voltage, overload, regeneration error , etc.	
Utility Functions		Gain adjustment, alarm history, JOG operation, origin search, etc.	
Regenerative Processing		100 VAC model: External regenerative resistor (optional) 200 VAC SGD V-R70A, -R90A, -1R6A, -2R8A: External regenerative resistor (optional) 200 VAC SGD V-470A, -550A, -590A, -780A: External regenerative resistor unit (optional) 200 VAC models other than shown above: Built-in regenerative resistor 400 VAC SGD V-210D, -260D, -280D, -370D: External regenerative resistor unit (optional) 400 VAC models other than shown above: Built-in regenerative resistor	
Overtravelling (OT) Prevention		Dynamic brake stop at P-OT or N-OT, deceleration to a stop, or free run to a stop	
Safety Functions	Input	/HWBB1, /HWBB2: Baseblock signal for power module	
	Output	EDM1: Status monitor (fixed output) of built-in safety circuit	
	Applicable Standards*2	EN954 category 3, IEC61508 SIL2	
Option Module		Fully-closed option module	

*1: Speed regulation is defined as follows:

$$\text{Speed regulation} = \frac{\text{No-load motor speed} - \text{Total load motor speed}}{\text{Rated motor speed}} \times 100\%$$

The motor speed may change due to voltage fluctuation or temperature fluctuation.

The ratio of speed changes to the rated speed represent speed regulation due to voltage and temperature fluctuations.

*2: Perform risk assessment for the system and confirm that the safety requirements for the standards are fulfilled before using the HWBB function.

Specifications

● Rotary Servomotors

Items		Specifications		
I/O Signal	Encoder Output Pulses	Phase A, phase B, phase C: line driver output The number of dividing pulse: Any setting ratio is available.		
		Sequence Input	Fixed Input	SEN signal
	Input Signals which can be allocated		Number of Channels	7 channels
			Functions	The signal allocation and positive/negative logic can be modified. Servo On (/S-ON), proportional control (/P-CON), alarm reset (/ALM-RST), forward run prohibited (P-OT), reverse run prohibited (N-OT), forward torque limit (/P-CL), reverse torque limit(/N-CL), internal set speed selection (/SPD-D, / SPD-A, /SPD-B), control selection (/C-SEL), zero clamping (/ZCLAMP), reference pulse inhibit (/INHIBIT), gain selection (/G-SEL)
	Sequence Output		Fixed Output	Servo alarm (ALM), alarm code (ALO1, ALO2, ALO3) outputs
		Output Signals which can be allocated	Number of Channels	3 channels
Functions	The signal allocation and positive/negative logic can be modified. Positioning completion (/COIN), speed coincidence detection (/V-CMP), servomotor rotation detection (/TGON), servo ready (/S-RDY), torque limit detection (/CLT), speed limit detection (/VLT), brake (/BK), warning (/WRAN), near (/NEAR)			
Panel Operator		Display	7-segment 5-digit LED (Red)	
		Switch	Push switch: 4 channels	
Torque Control	Analog Input	Reference Voltage	3 VDC (Variable setting range: ± 1 to 10 VDC) at rated torque max. input voltage: ± 12 V	
		Input Impedance	About 14 k Ω	
		Circuit Time Constant	16 μ s	
Speed Control	Analog Input	Reference Voltage	6 VDC (Variable setting range: ± 2 to 10 VDC) at rated speed max. input voltage: ± 12 V	
		Input Impedance	About 14 k Ω	
		Circuit Time Constant	30 μ s	
	Internal Set Speed Control	Rotation Direction Selection	Switches the direction by /P-CON (/SPD-D)	
	Function	Speed Selection	Speed 1 to 3 selection	
		Soft Start Setting	0 to 10 s (can be set individually for acceleration and deceleration.)	
Position Control	Reference Pulse	Type	Sign + pulse train, 90° phase difference 2-phase pulse (phase A + phase B), or CCW + CW pulse train	
		Form	Non-insulated line driver (+5 V level), open collector	
		Max. Input Pulse Frequency*	Sign+ Pulse train : 4 Mpps CW+ CCW pulse train : 4 Mpps 90° phase difference 2-phase pulse × 1 multiplier : 1 Mpps (before multiplier) × 2 multiplier : 1 Mpps (before multiplier) × 4 multiplier : 1 Mpps (before multiplier) Open collector : 200 kpps	
	Clear Signal	Function	Clears error pulse by external signals.	
		Form	Applicable to line driver, open collector	

*: If the maximum reference frequency exceeds 1 Mpps, use a shielded cable for I/O signals and ground both ends of the shield. Connect the shield at the SERVOPACK to the connector shell.

Specifications

●Linear Servomotors

Items		Specifications		
I/O Signal	Encoder Output Pulses		Phase A, phase B, phase C: line driver output The number of dividing pulse: Any setting ratio is available.	
	Sequence Input	Fixed Input	SEN signal	
		Input Signals which can be allocated	Number of Channels	7 channels
			Functions	The signal allocation and positive/negative logic can be modified. Servo ON (/S-ON), proportional control (/P-CON), alarm reset (/ALM-RST), forward run prohibited (P-OT), reverse run prohibited (N-OT), forward external force limit (/P-CL), reverse external force limit (/N-CL), internal set speed selection (/SPD-D, /SPD-A, /SPD-B), control selection (/C-SEL), zero clamping (/ZCLAMP), reference pulse inhibit (/INHIBIT), gain selection (/G-SEL), polarity detection (P-DET)
			Fixed Output	Servo alarm (ALM), alarm code (ALO1, ALO2, ALO3) outputs
	Sequence Output	Output Signals which can be allocated	Number of Channels	3 channels
Functions			The signal allocation and positive/negative logic can be modified. Positioning completion (/COIN), speed coincidence detection (/V-CMP), servomotor movement detection (/TGON), servo ready (/S-RDY), force limit detection (/CLT), speed limit detection (/VLT), brake (/BK), warning (/WARN), near (/NEAR)	
Panel Operator		Display	7-segment 5-digit LED (Red)	
		Switch	Push switch: 4 channels	
Force Control	Analog Input	Reference Voltage	3 VDC (Variable setting range: ± 1 to 10 VDC) at rated torque max. input voltage: ± 12 V	
		Input Impedance	About 14 k Ω	
		Circuit Time Constant	16 μ s	
Speed Control	Analog Input	Reference Voltage	6 VDC (Variable setting range: ± 2 to 10 VDC) at rated speed max. input voltage: ± 12 V	
		Input Impedance	About 14 k Ω	
		Circuit Time Constant	30 μ s	
	Internal Set Speed Control	Movement Direction Selection	/P-CON (/SPD-D) signal	
	Function	Speed Selection	Speed 1 to 3 selection	
		Soft Start Setting	0 to 10 s (can be set individually for acceleration and deceleration.)	
Position Control	Reference Pulse	Type	Sign+ pulse train, 90° phase difference 2-phase pulse (phase A+phase B), or CCW+CW pulse train	
		Form	Non-insulated line driver (+5 V level), open collector	
		Max. Input Pulse Frequency*	Sign+ Pulse train : 4 Mpps CW+ CCW pulse train : 4 Mpps 90° phase difference 2-phase pulse ×1 multiplier : 1 Mpps (before multiplier) ×2 multiplier : 1 Mpps (before multiplier) ×4 multiplier : 1 Mpps (before multiplier) Open collector : 200 kpps	
	Clear Signal	Function	Clears error pulse by external signals.	
		Form	Applicable to line driver, open collector	

*: If the maximum reference frequency exceeds 1 Mpps, use a shielded cable for I/O signals and ground both ends of the shield.
Connect the shield at the SERVOPACK to the connector shell.

Power Supply Capacities and Power Losses

The following table shows SERVOPACK's power supply capacities and power losses at the rated output.

Main Circuit Power Supply	Applicable Servomotor Max. Capacity kW	SERVOPACK Model SGD V-	Power Supply Capacity kVA	Output Current Arms	Main Circuit Power Loss W	Regenerative Resistor Power Loss	Control Circuit Power Loss	Total Power Loss
						W	W	W
Signal-phase 100 V	0.05	R70F	0.2	0.66	5.4	—	17	22.4
	0.1	R90F	0.3	0.91	7.8			24.8
	0.2	2R1F	0.7	2.1	14.4			31.4
	0.4	2R8F	1.4	2.8	25.6			42.6
Single-phase 200 V	0.05	R70A	0.2	0.66	5.2	—	17	22.2
	0.1	R90A	0.3	0.91	7.4			24.4
	0.2	1R6A	0.7	1.6	13.7			30.7
	0.4	2R8A	1.2	2.8	24.9			41.9
	0.75	5R5A	1.9	5.5	52.7	8	77.7	
	1.5	120A	4	11.6	68.2	10	22	100.2
Three-phase 200 V	0.05	R70A	0.2	0.66	5.1	—	17	22.1
	0.1	R90A	0.3	0.91	7.3			24.3
	0.2	1R6A	0.6	1.6	13.5			30.5
	0.4	2R8A	1	2.8	24.0			41.0
	0.5	3R8A	1.4	3.8	20.1	8	45.1	
	0.75	5R5A	1.6	5.5	43.8		68.8	
	1.0	7R6A	2.3	7.6	53.6	10	78.6	
	1.5	120A	3.2	11.6	65.8		97.8	
	2.0	180A	4	18.5	111.9	16	22	149.9
	3.0	200A	5.9	19.6	113.8		161.4	
	5.0	330A	7.5	32.9	263.7	36	27	326.7
	6.0	470A	10.7	46.9	279.4	(180)*1	33	312.4
	7.5	550A	14.6	54.7	357.8	(350)*2		390.8
	11	590A	21.7	58.6	431.7	(350)*2	48	479.7
15	780A	29.6	78	599.0	647.0			
Three-phase 400 V	0.5	1R9D	1.1	1.9	24.6	14	21	59.6
	1.0	3R5D	2.3	3.5	46.1			81.1
	1.5	5R4D	3.5	5.4	71.3			106.3
	2.0	8R4D	4.5	8.4	77.9	28	25	130.9
	3.0	120D	7.1	11.9	108.7			161.7
	5.0	170D	11.7	16.5	161.1	36	24	221.1
	6.0	210D	12.4	20.8	172.7	(180)*3	27	199.7
	7.5	260D	14.4	25.7	218.6			245.6
	11	280D	21.9	28.1	294.6	(350)*4	30	324.6
	15	370D	30.6	37.2	403.8			433.8

*1: For the optional JUSP-RA04-E regenerative resistor unit.

*2: For the optional JUSP-RA05-E regenerative resistor unit.

*3: For the optional JUSP-RA18-E regenerative resistor unit.

*4: For the optional JUSP-RA19-E regenerative resistor unit.

Notes: 1 SGD V-R70F, -R90F, -2R1F, -2R8F, -R70A, -R90A, -1R6A, and -2R8A SERVOPACKs do not have built-in regenerative resistors.

If the regenerative energy exceeds the specified value, connect an external regenerative resistor (optional).

2 SGD V-470A, -550A, -590A, -780A, -210D, -260D, -280D, -370D SERVOPACKs do not have built-in regenerative resistors.

Be sure to connect a regenerative resistor unit (optional) or an external regenerative resistor (optional). For selection details, refer to page 360.

3 Regenerative resistor power losses are allowable losses. Take the following action if this value is exceeded.

• Remove the lead or short bar that is short-circuiting the SERVOPACK main circuit terminal B2 and B3.

(SGDV-3R8A, -5R5A, -7R6A, -120A, -180A, -200A, -330A, or 400-V class SERVOPACKs.)

• Install an external regenerative resistor (optional). For selection details, refer to page 360.

External Dimensions Units: mm

● Base-mounted SERVOPACKS

(1) Single-phase 100 VAC, Model: SGD V-R70F0□A, -R90F0□A, and -2R1F0□A

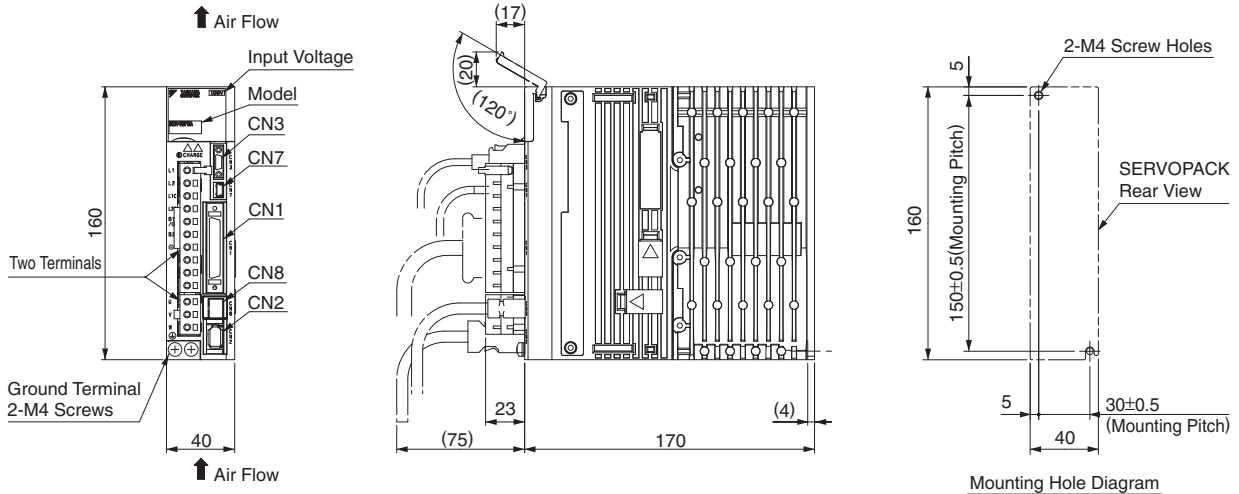

Approx. Mass: 1.0 kg

(2) Single-phase 100 VAC, Model: SGD V-2R8F0□A

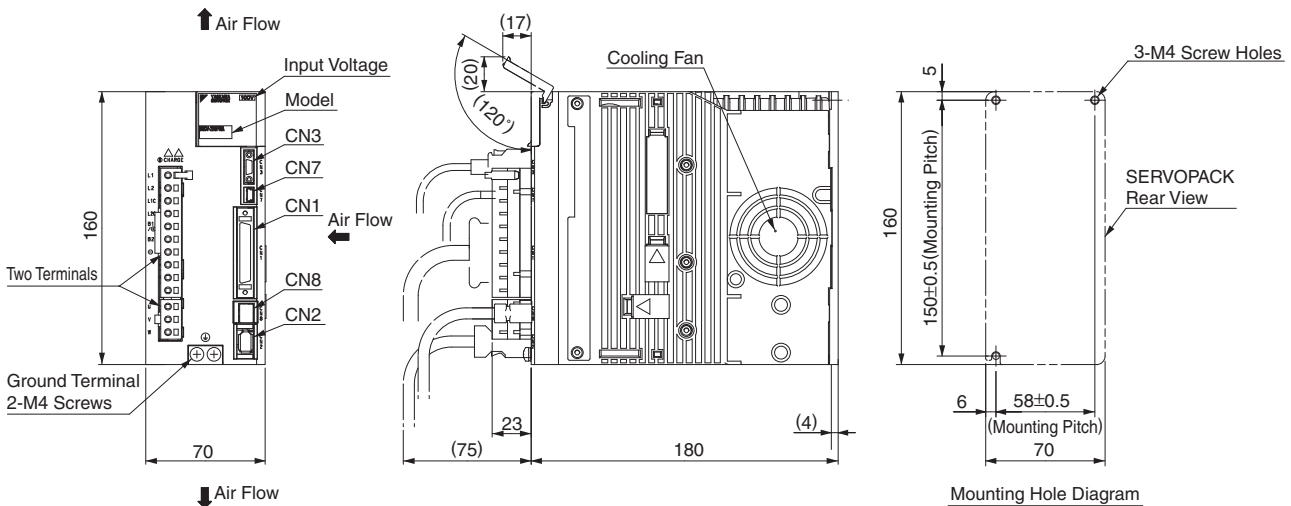

Approx. Mass: 1.5 kg

(3) Three-phase 200 VAC, Model: SGD V-R70A0□A, -R90A0□A, and -1R6A0□A

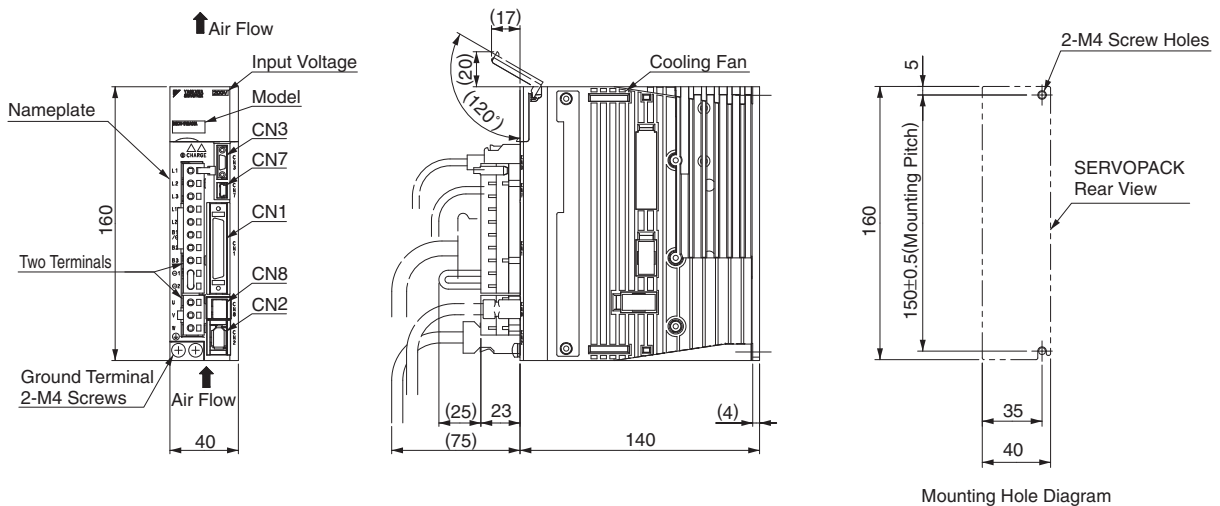

Approx. Mass: 0.9 kg

External Dimensions Units: mm

(4) Three-phase 200 VAC, Model: SGDV-2R8A0□A

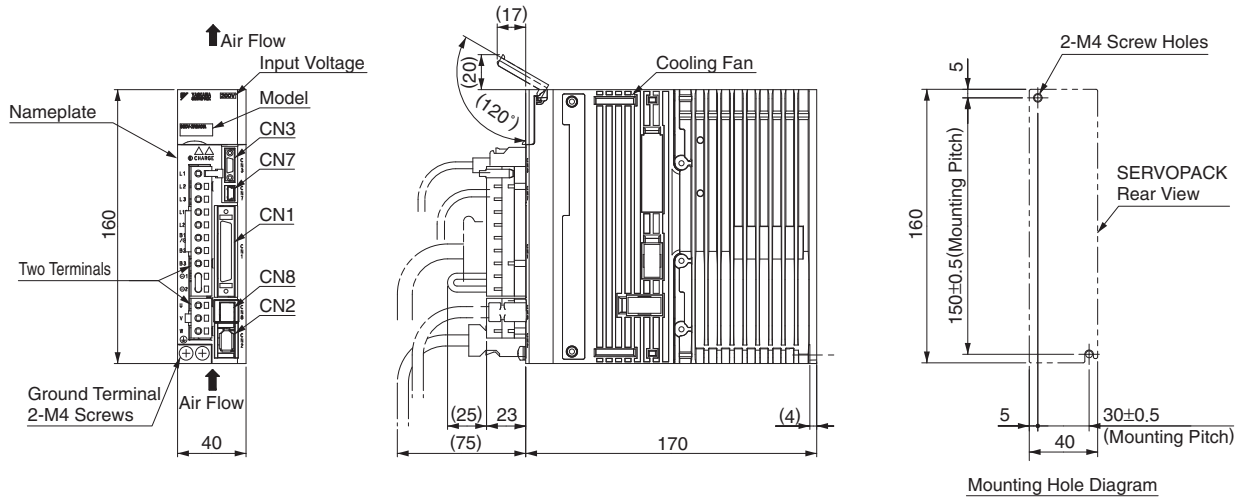

Approx. Mass: 1.0 kg

(5) Three-phase 200 VAC, Model: SGDV-3R8A0□A, -5R5A0□A, and 7R6A0□A

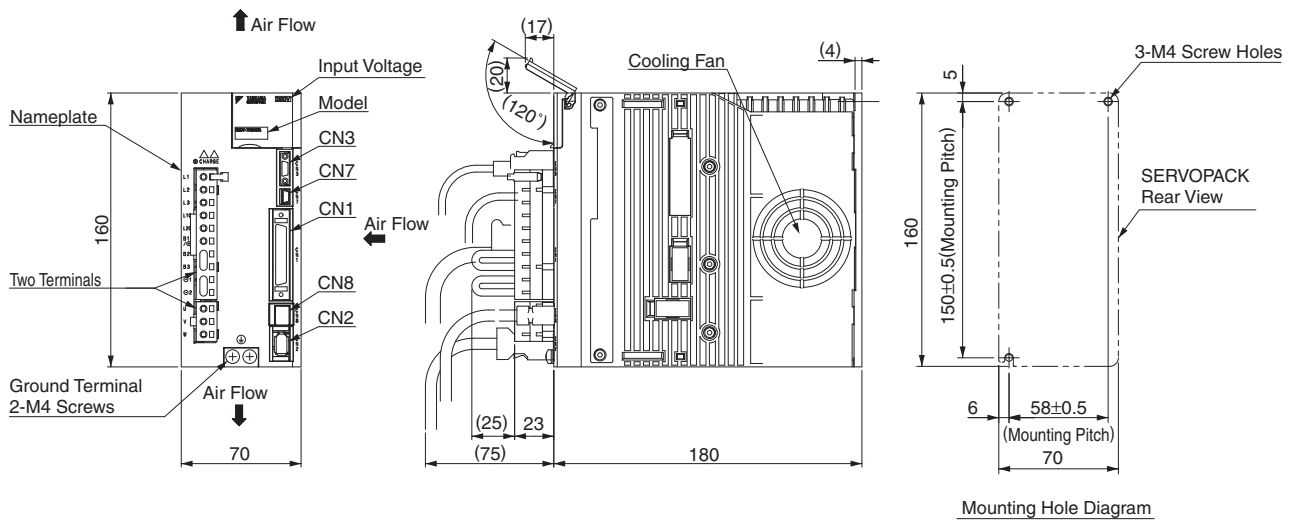

Approx. Mass: 1.5 kg

(6) Three-phase 200 VAC, Model: SGDV-120A0□A

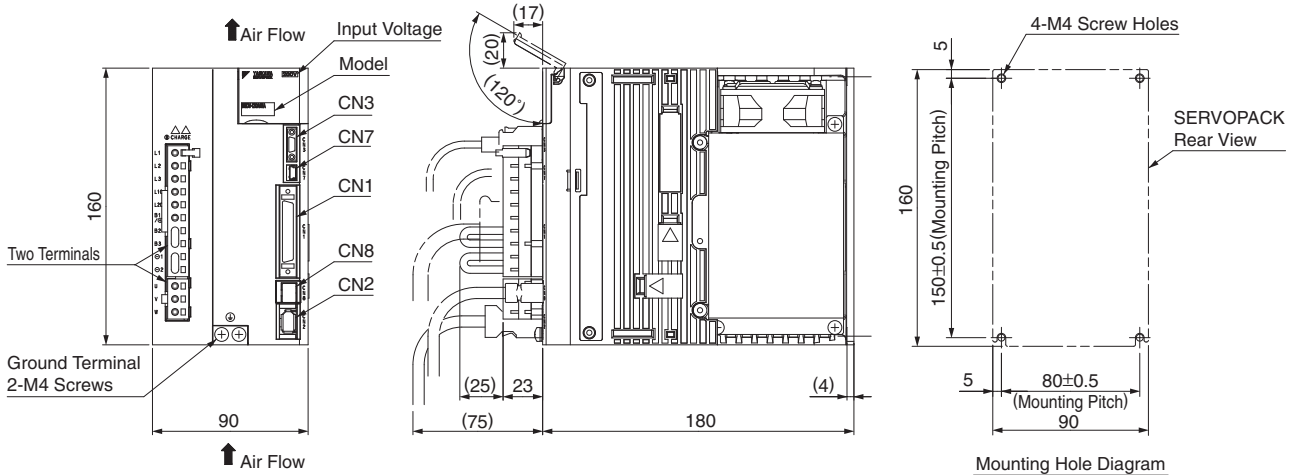

Approx. Mass: 2.4 kg

Analog/Pulse Type SERVOPACKS

External Dimensions Units: mm

(7) Single-phase 200 VAC, Model: SGDV-120A0□A008000 (1.5 kW, single-phase input type)
 Three-phase 200 VAC, Model: SGDV-180A0□A and -200A0□A

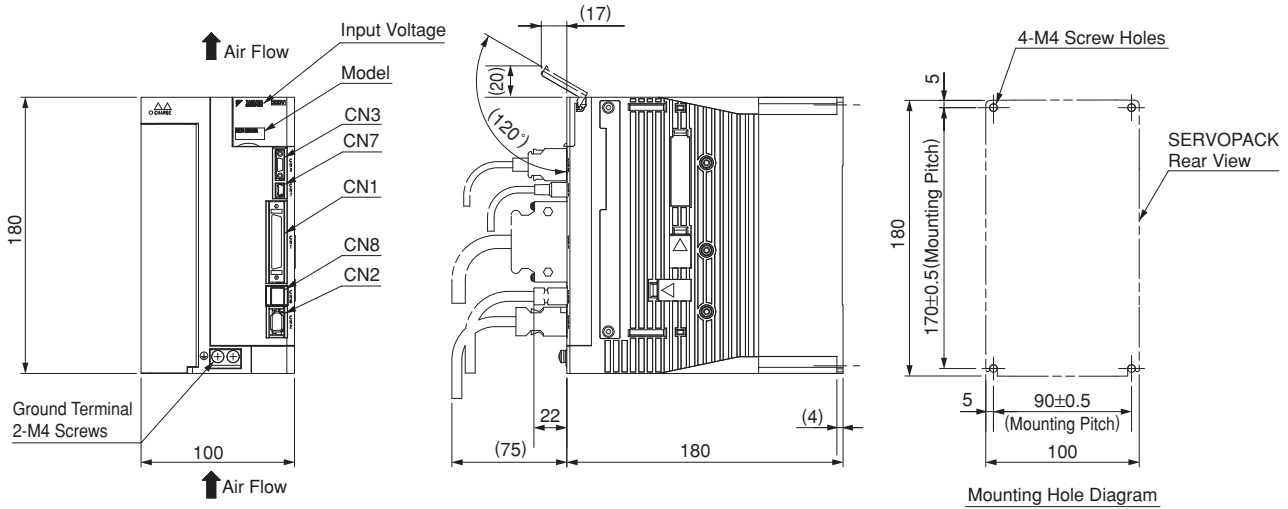

Approx. Mass: 2.8 kg

(8) Three-phase 200 VAC, Model: SGDV-330A0□A

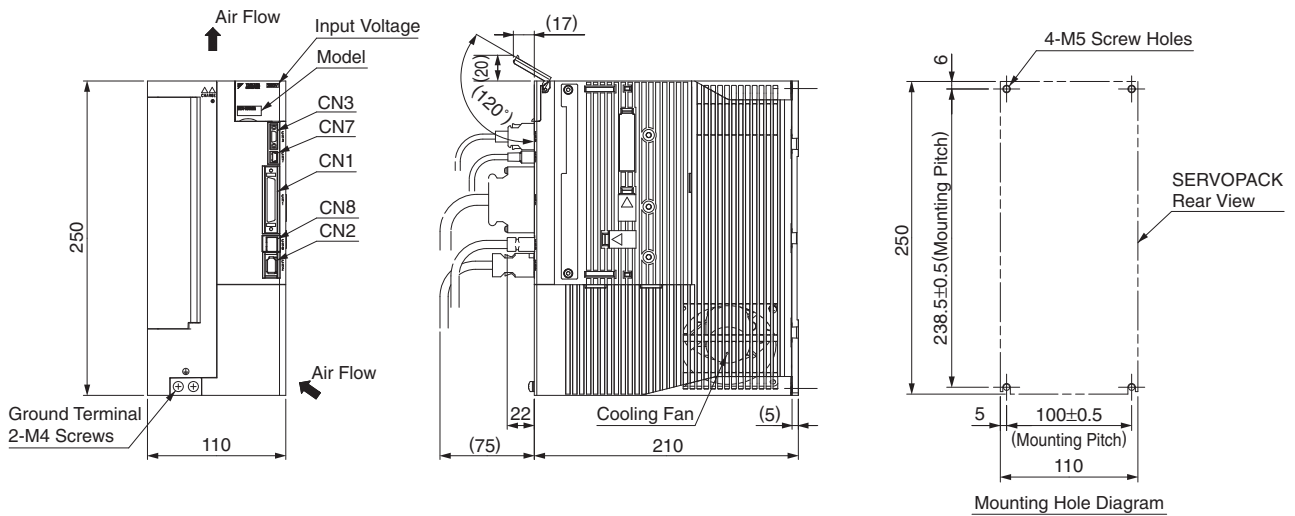

Approx. Mass: 4.6 kg

External Dimensions Units: mm

(9) Three-phase 200 VAC, Model: SGDV-470A0□A and -550A0□A

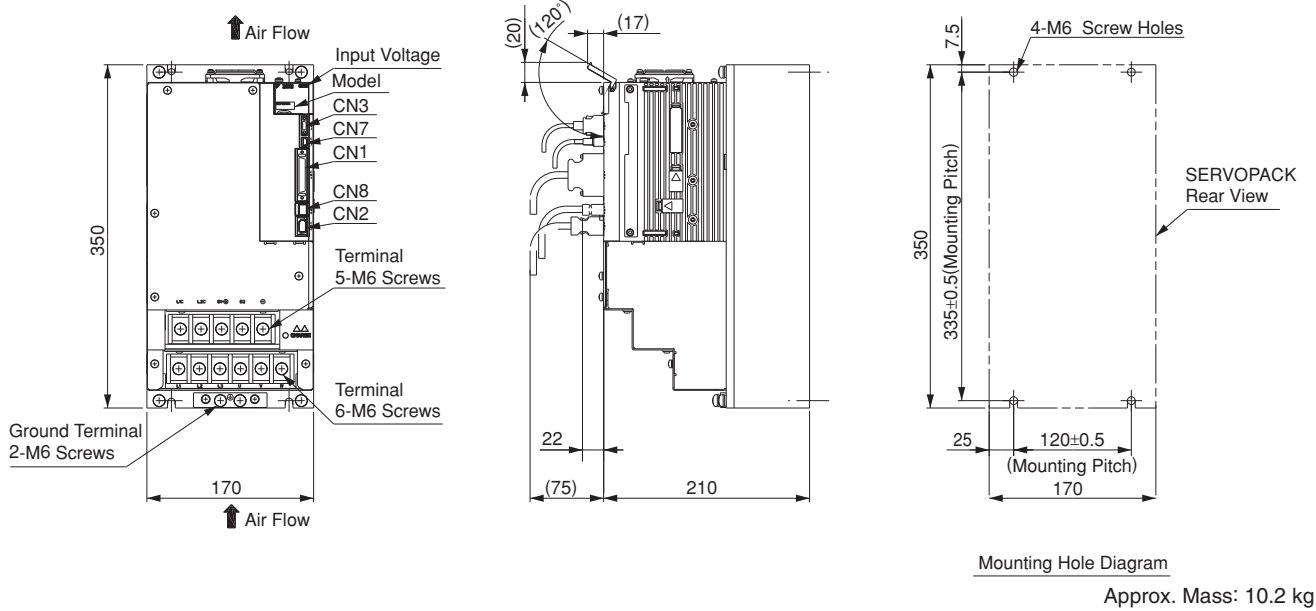

(10) Three-phase 200 VAC, Model: SGDV-590A0□A and -780A0□A

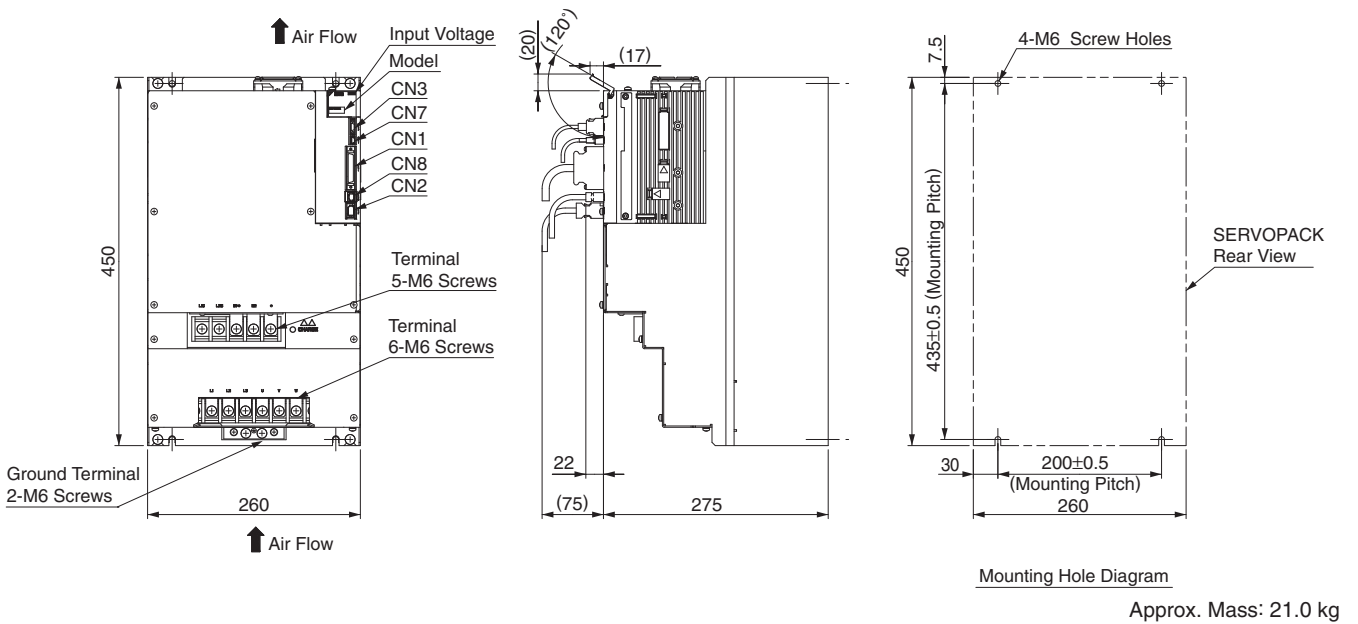

Analog/Pulse Type SERVOPACKs

External Dimensions Units: mm

(11) Three-phase 400 VAC, Model: SGDV-1R9D0□A, -3R5D0□A, and -5R4D0□A

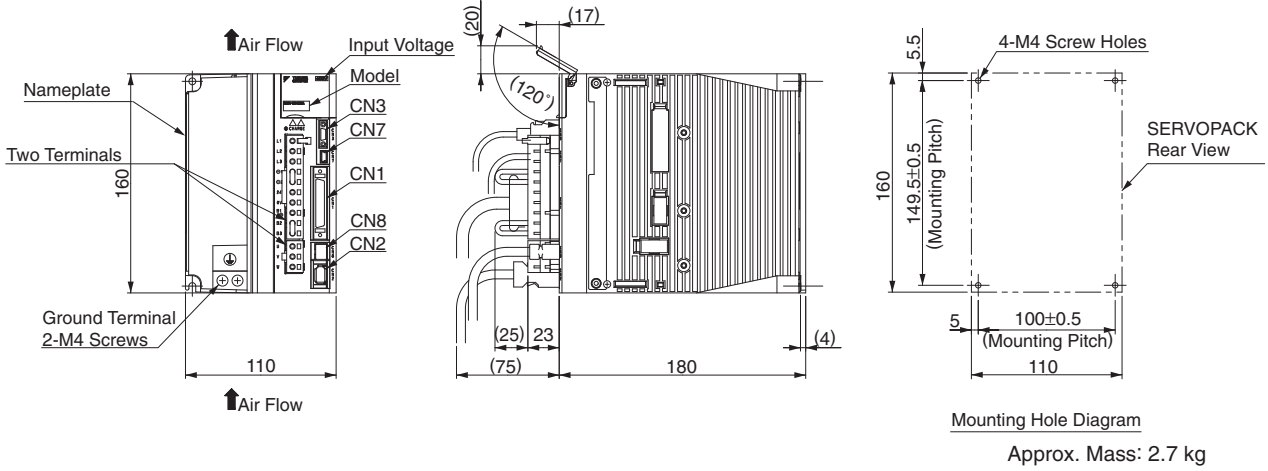

(12) Three-phase 400 VAC, Model: SGDV-8R4D0□A and -120D0□A

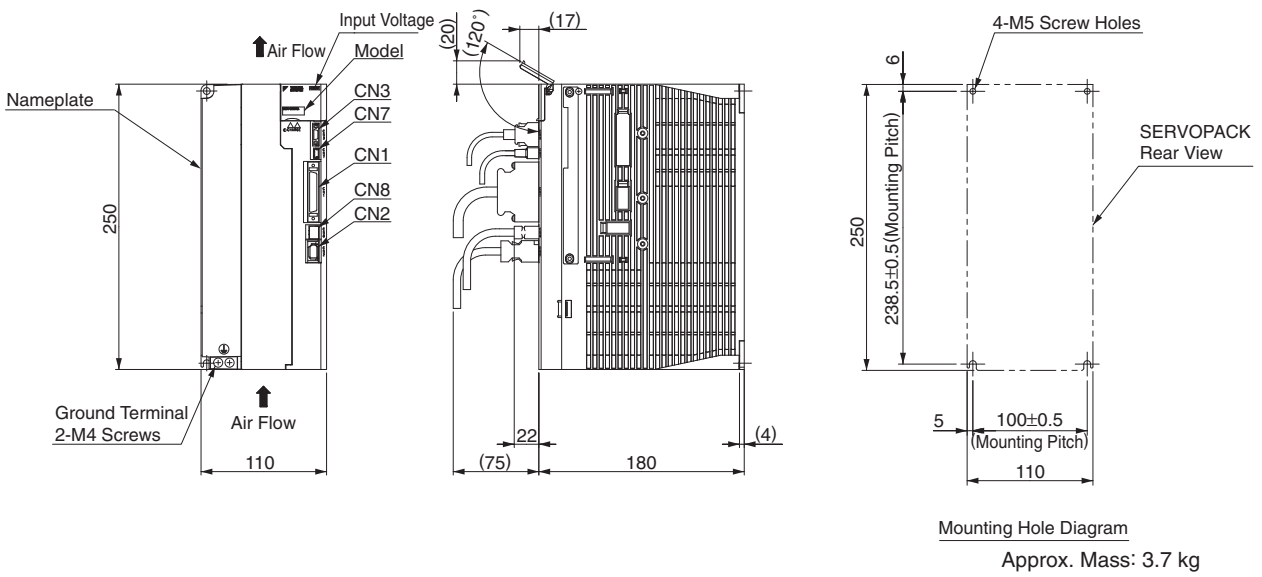

(13) Three-phase 400 VAC, Model: SGDV-170D0□A

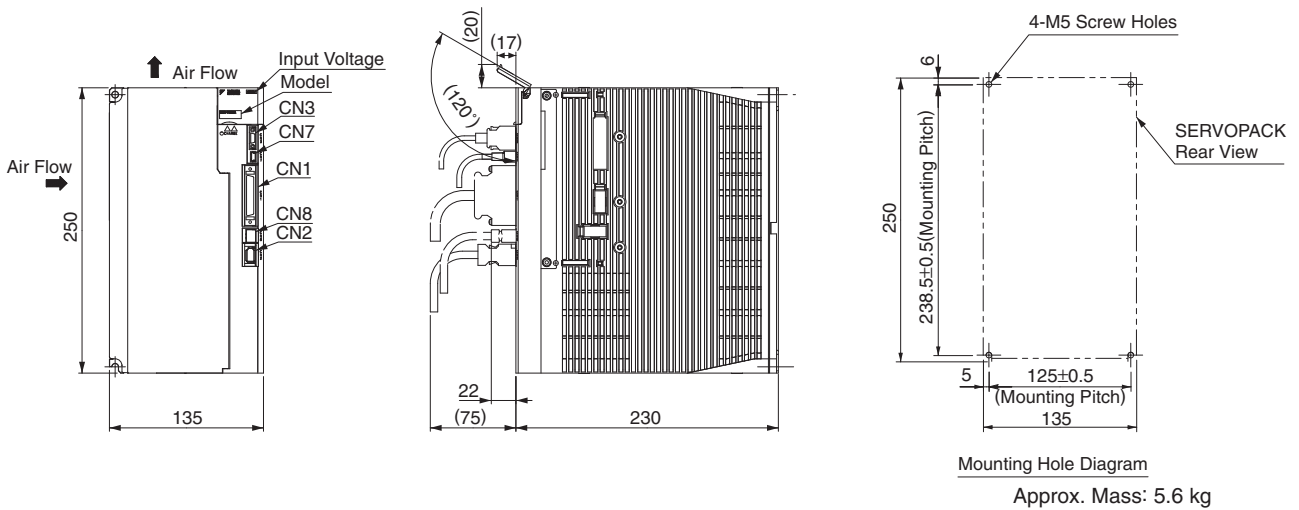

External Dimensions Units: mm

(14) Three-phase 400 VAC, Model: SGDV-210D0□A and -260D0□A

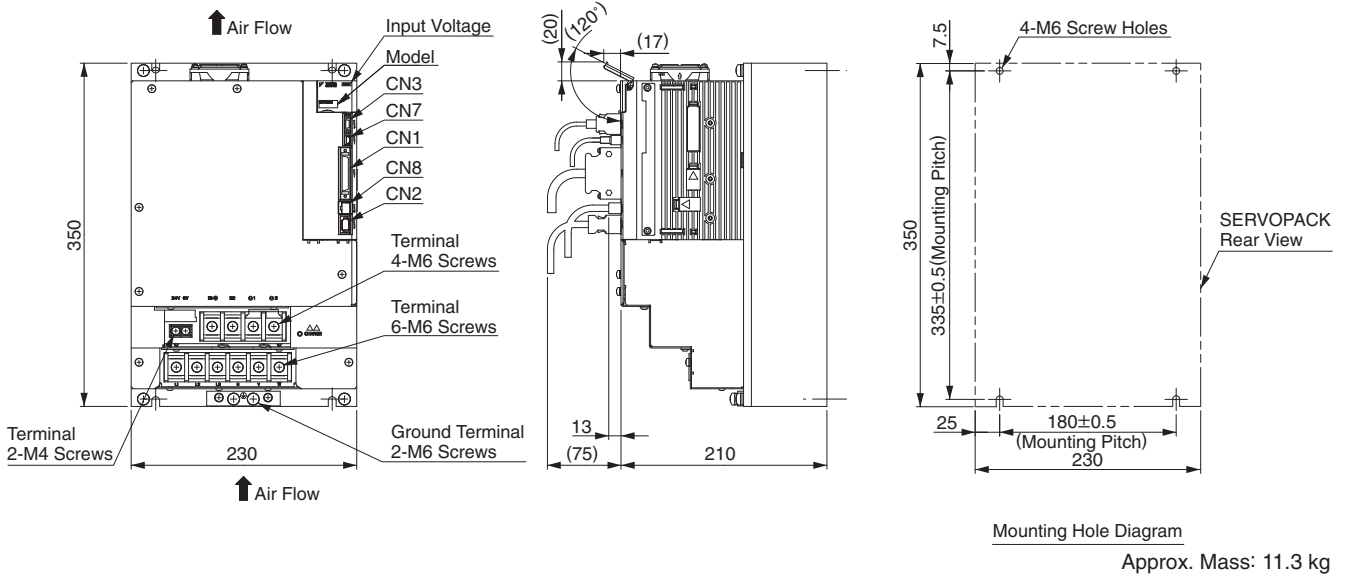

(15) Three-phase 400 VAC, Model: SGDV-280D0□A and -370D0□A

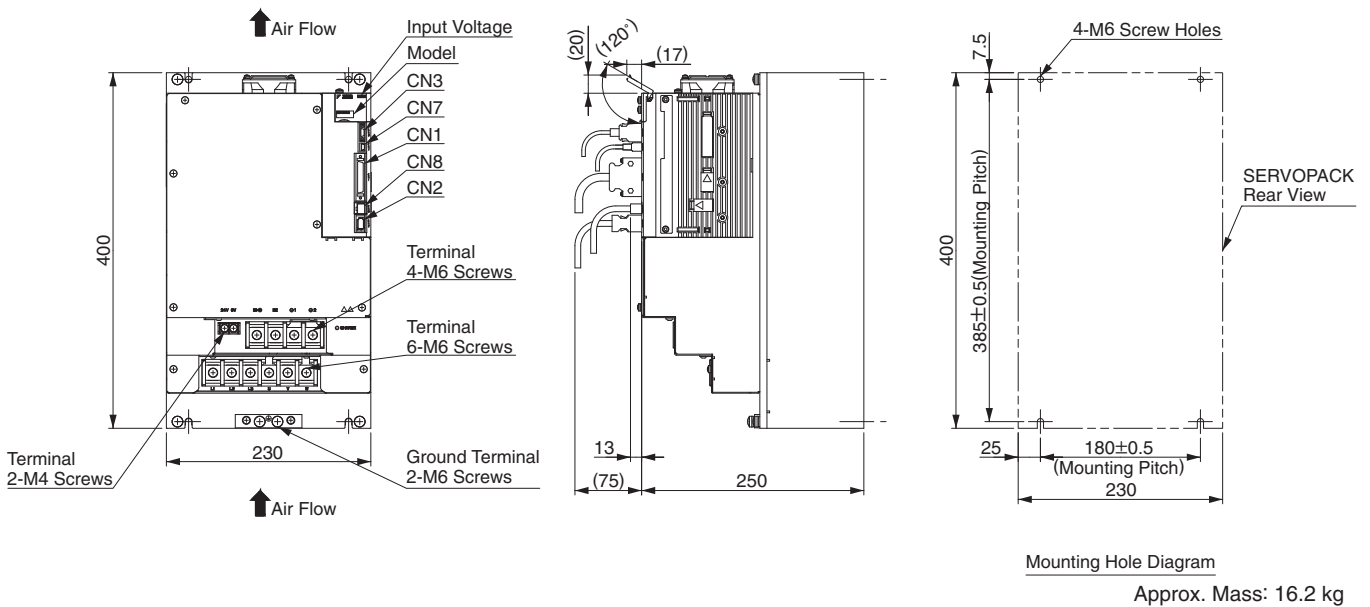

Connectors for Base-mounted SERVOPACKS

Port	Model	Pin	Manufacturer
CN1	10250-52A2PL	50	Sumitomo 3M Ltd.
CN2	53984-0671	6	Molex Japan Co., Ltd.
CN3	HDR-EC14LFDTN-SLE-PLUS	14	Honda Tsushin Kogyo Co., Ltd.
CN7	MNC23-5K5H00	5	ADVANCED-CONNECTEK INC.
CN8	1981080-1	8	Tyco Electronics AMP K.K.

Note: The connectors above or their equivalents are used for SERVOPACKS.

External Dimensions Units: mm

● Rack-mounted SERVOPACKs (6 kW or more models: duct-ventilated)

(1) Single-phase 100 VAC, Model: SGDV-R70F0□A001, -R90F0□A001, and -2R1F0□A001

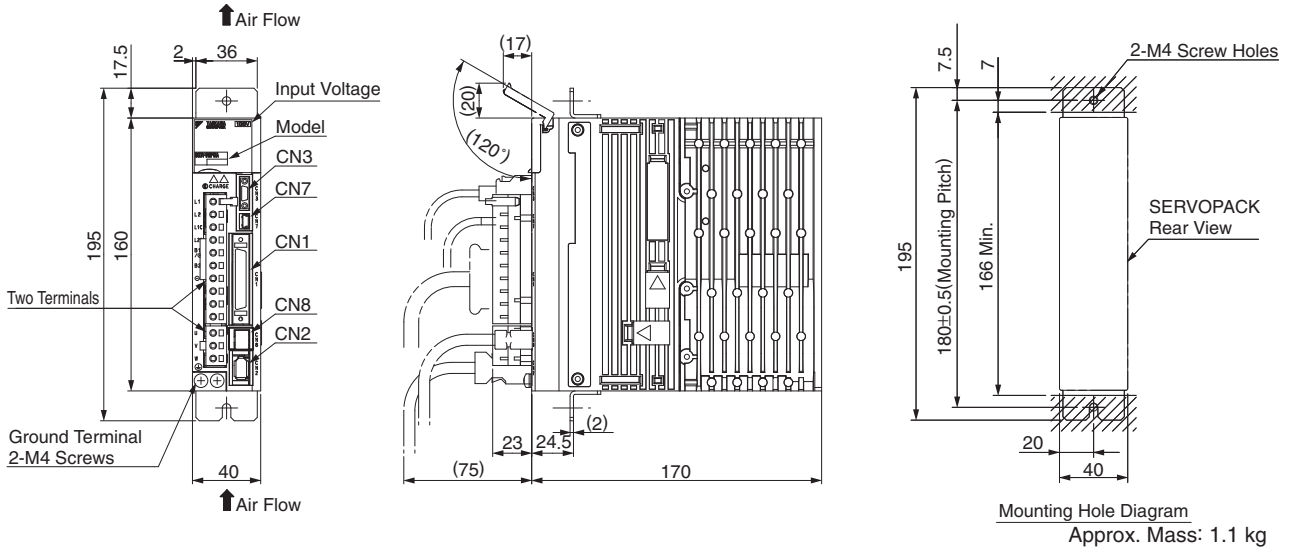

(2) Single-phase 100 VAC, Model: SGDV-2R8F0□A001

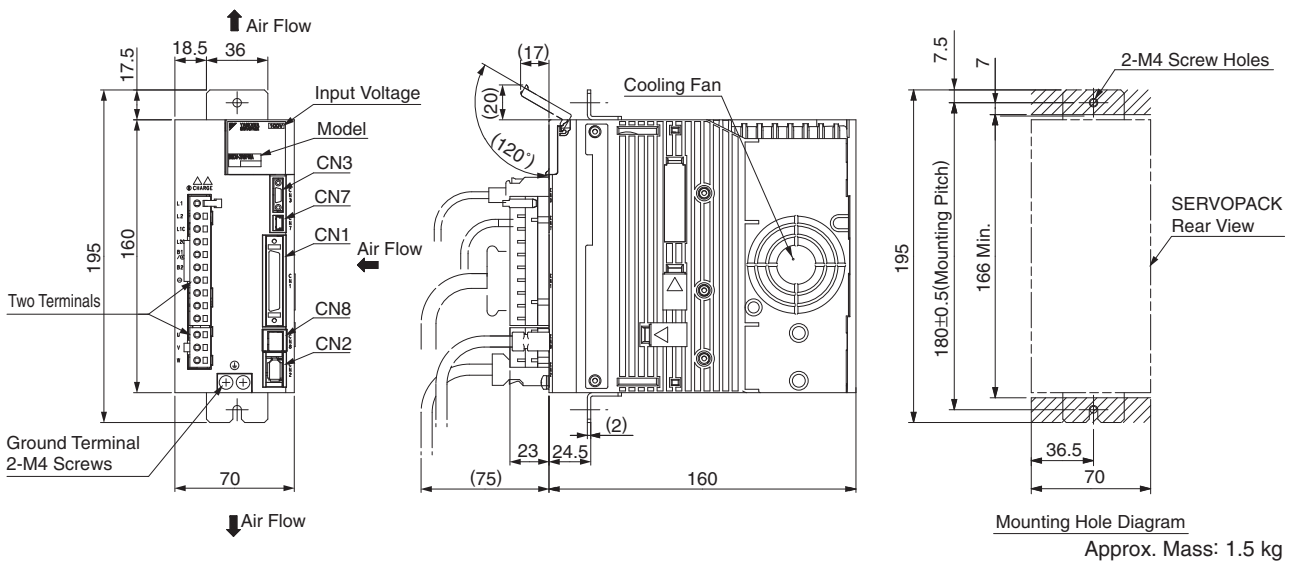

(3) Three-phase 200 VAC, Model: SGDV-R70A0□A001, -R90A0□A001, and -1R6A0□A001

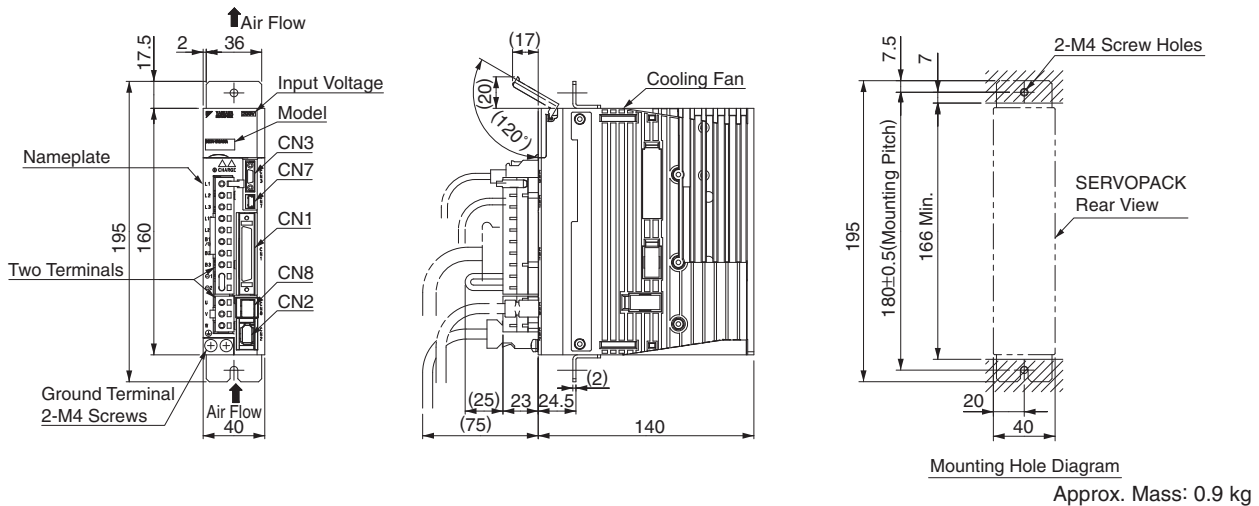

External Dimensions Units: mm

(4) Three-phase 200 VAC, Model: SGDV-2R8A0□A001

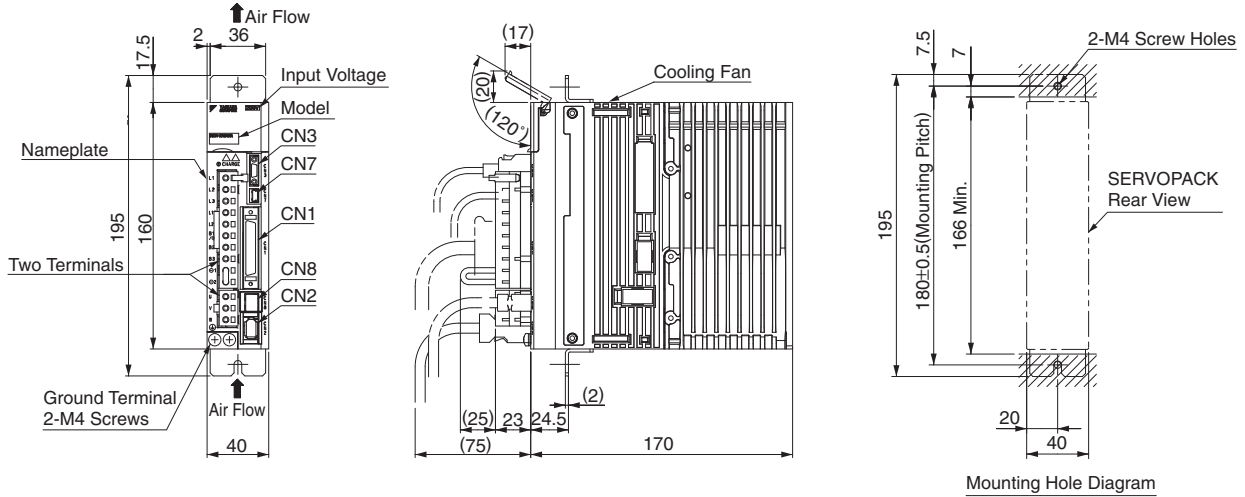

Approx. Mass: 1.0 kg

(5) Three-phase 200 VAC, Model: SGDV-3R8A0□A001, -5R5A0□A001, and -7R6A0□A001

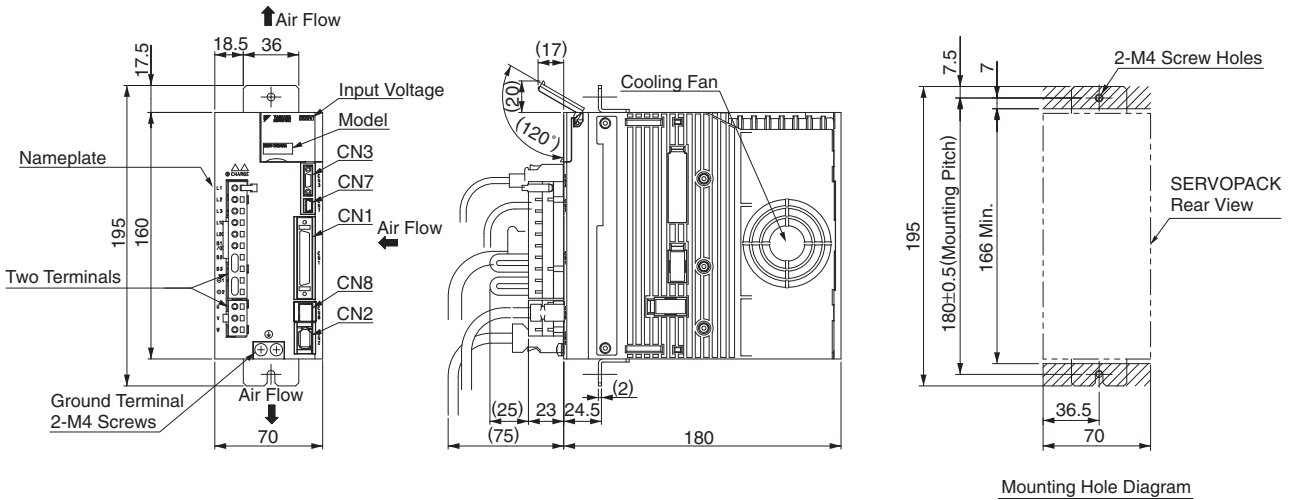

Approx. Mass: 1.5 kg

(6) Three-phase 200 VAC, Model: SGDV-120A0□A001

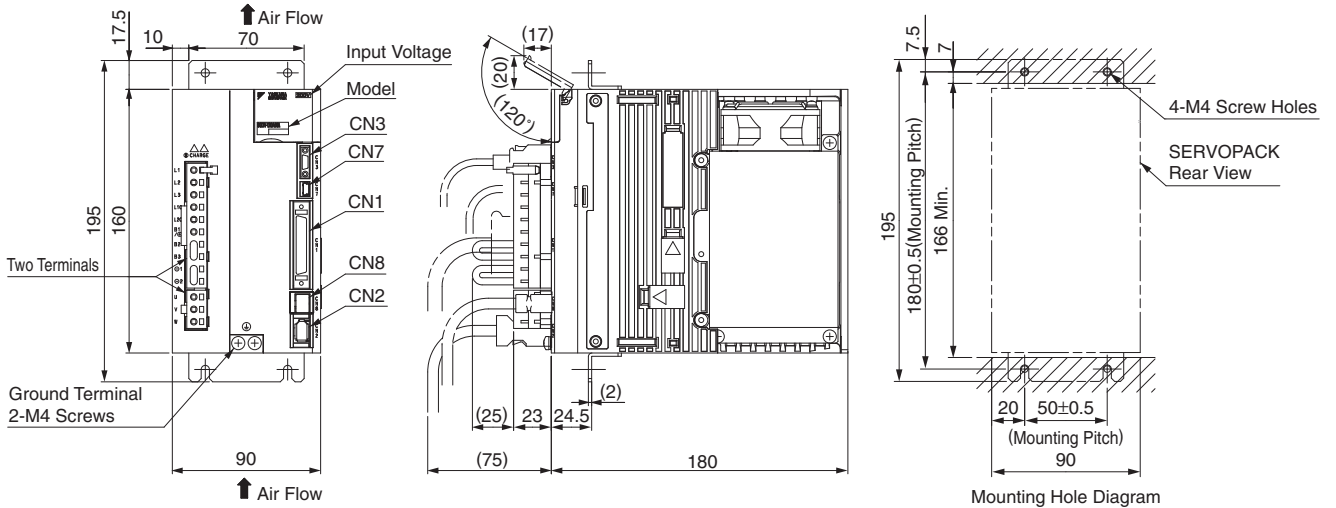

Approx. Mass: 2.5 kg 270

External Dimensions Units: mm

(7) Single-phase 200 VAC, Model: SGDV-120A0□A009000 (1.5 kW, single-phase input type)
 Three-phase 200 VAC, Model: SGDV-180A0□A001 and -200A0□A001

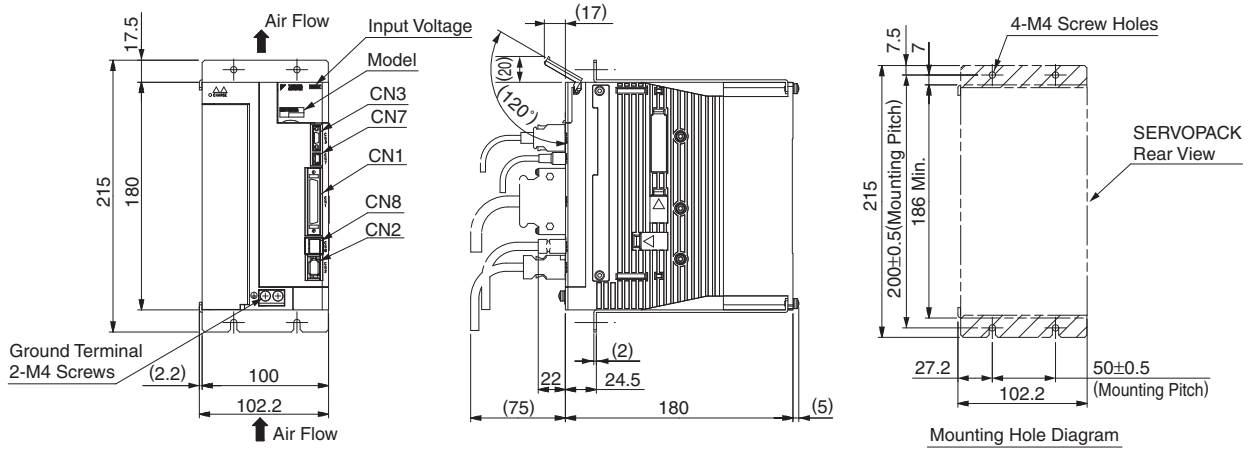

Approx. Mass: 3.1 kg

(8) Three-phase 200 VAC, Model: SGDV-330A0□A001

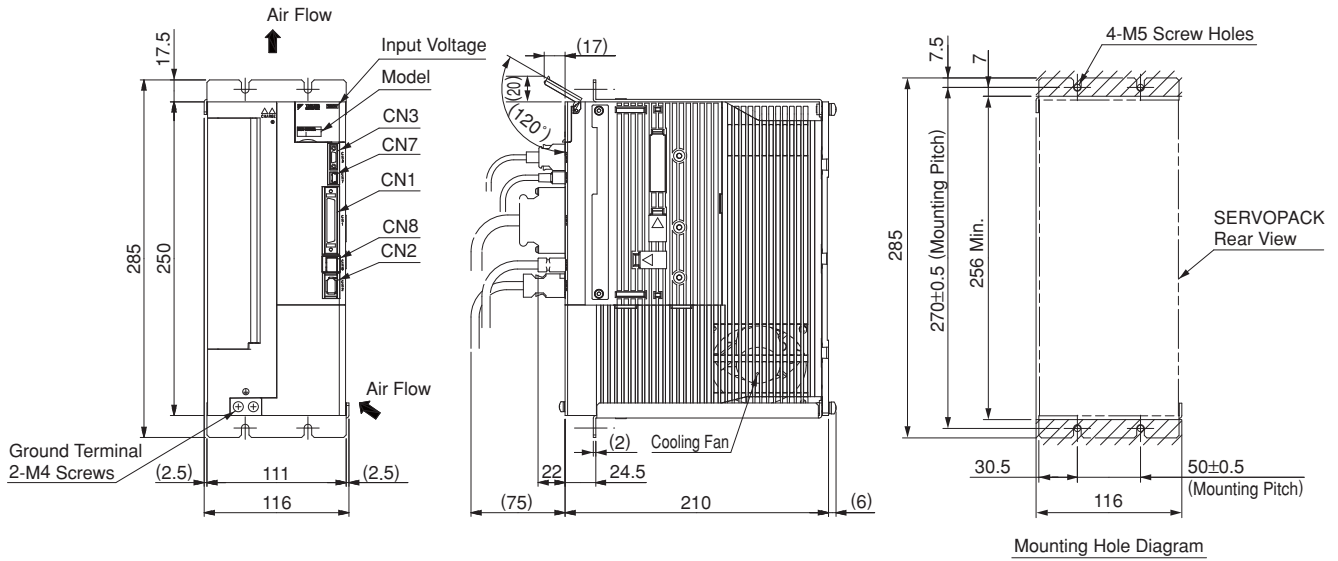

Approx. Mass: 5.0 kg

External Dimensions Units: mm

(9) Three-phase 200 VAC, Model: SGDV-470A0□A001 and -550A□A001 (Duct-ventilated type)

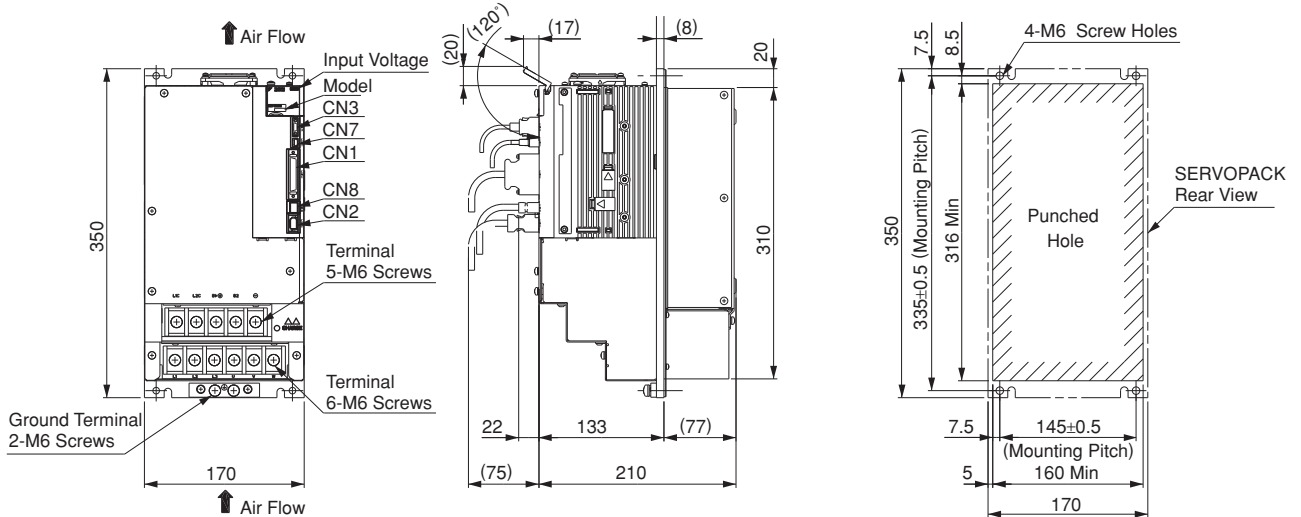

Mounting Hole Diagram

Approx. Mass: 8.5 kg

(10) Three-phase 200 VAC, Model: SGDV-590A0□A001 and -780A□A001 (Duct-ventilated type)

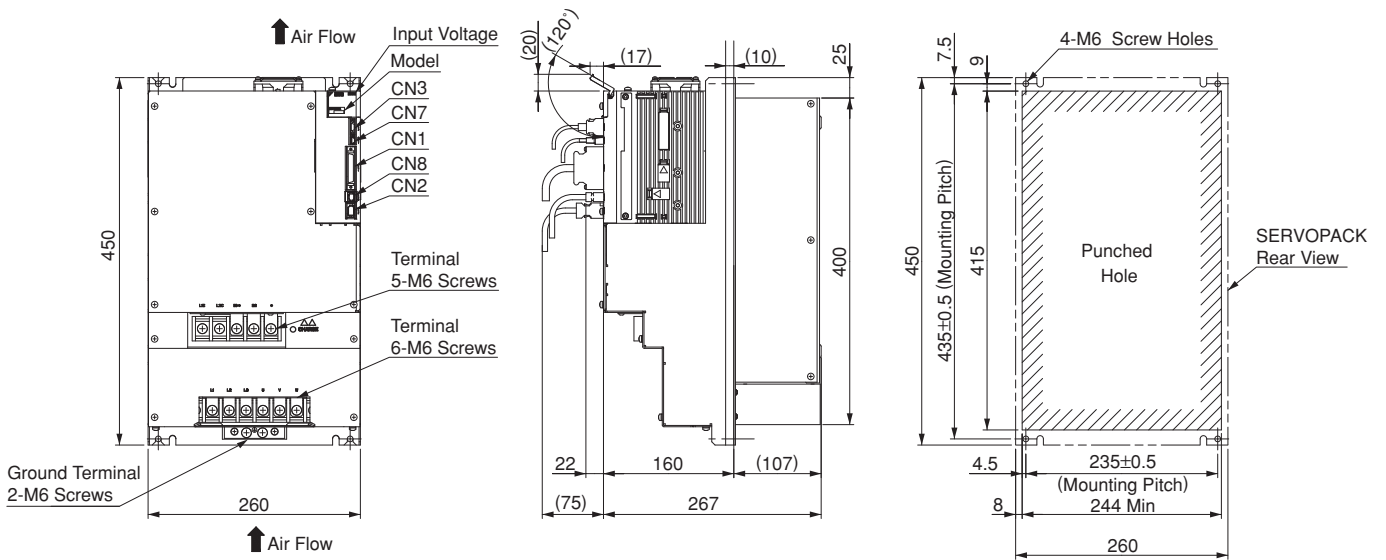

Mounting Hole Diagram

Approx. Mass: 16.0 kg

External Dimensions Units: mm

(11) Three-phase 400 VAC, Model: SGDV-1R9D0□A001, -3R5D0□A001, and -5R4D0□A001

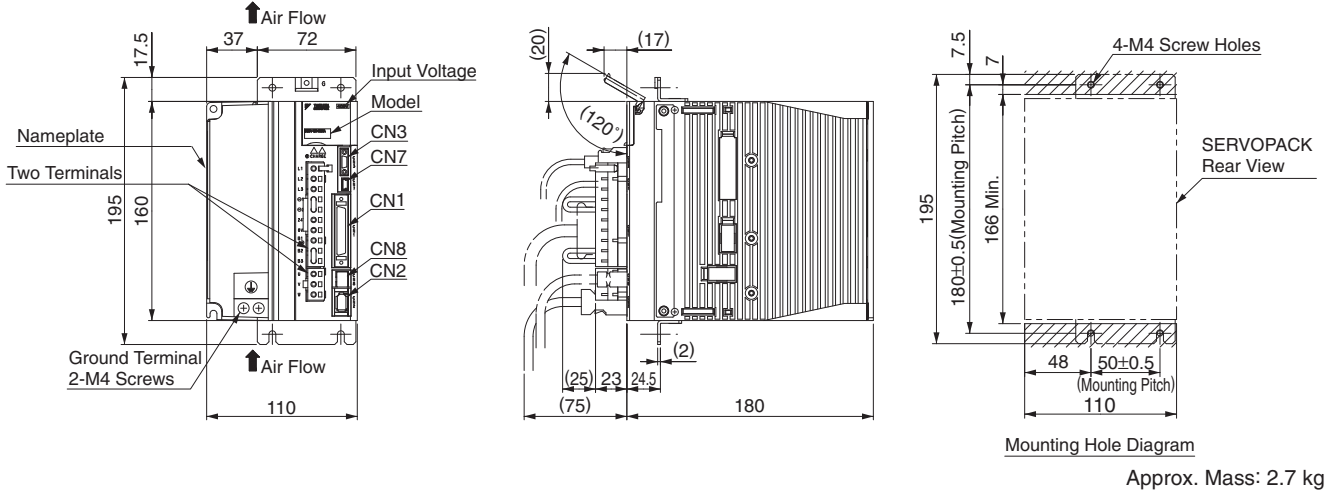

(12) Three-phase 400 VAC, Model: SGDV-8R4D0□A001 and -120D0□A001

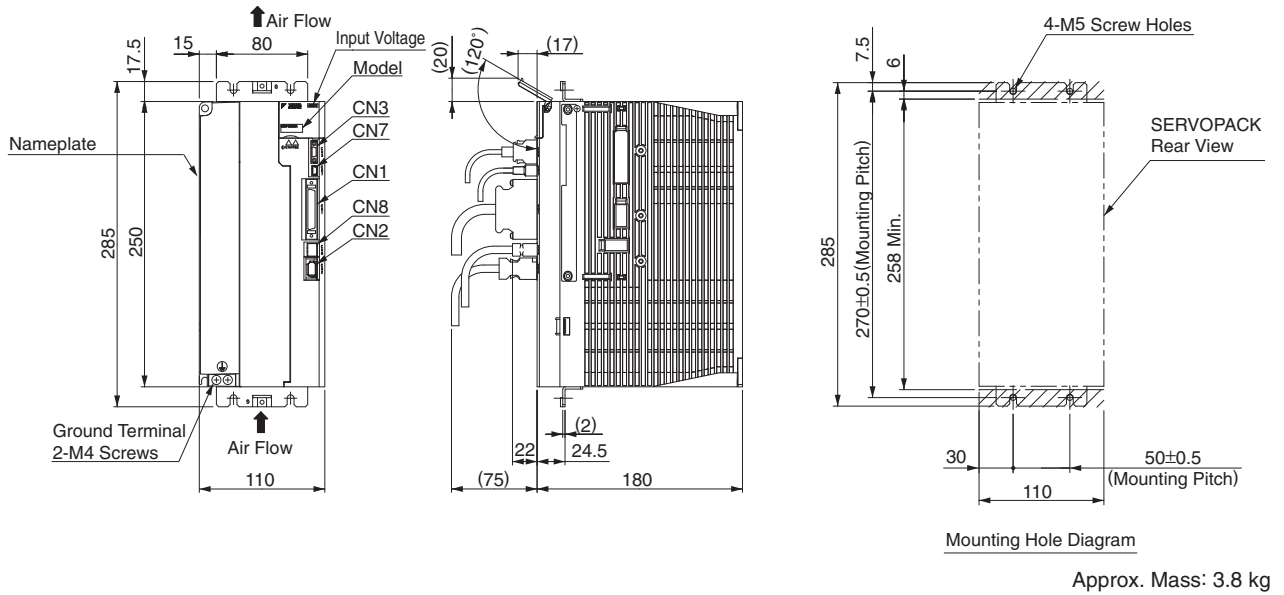

(13) Three-phase 400 VAC, Model: SGDV-170D0□A001

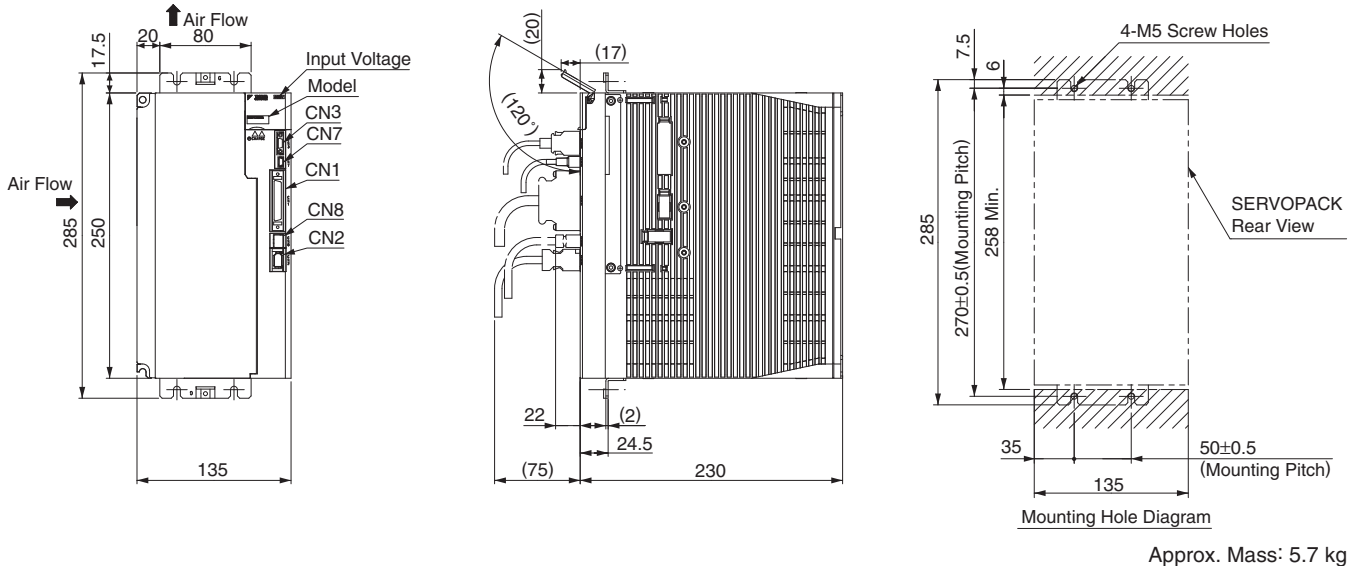

External Dimensions Units: mm

(14) Three-phase 400 VAC, Model: SGDV-210D0□A001 and -260D0□A001 (Duct-ventilated type)

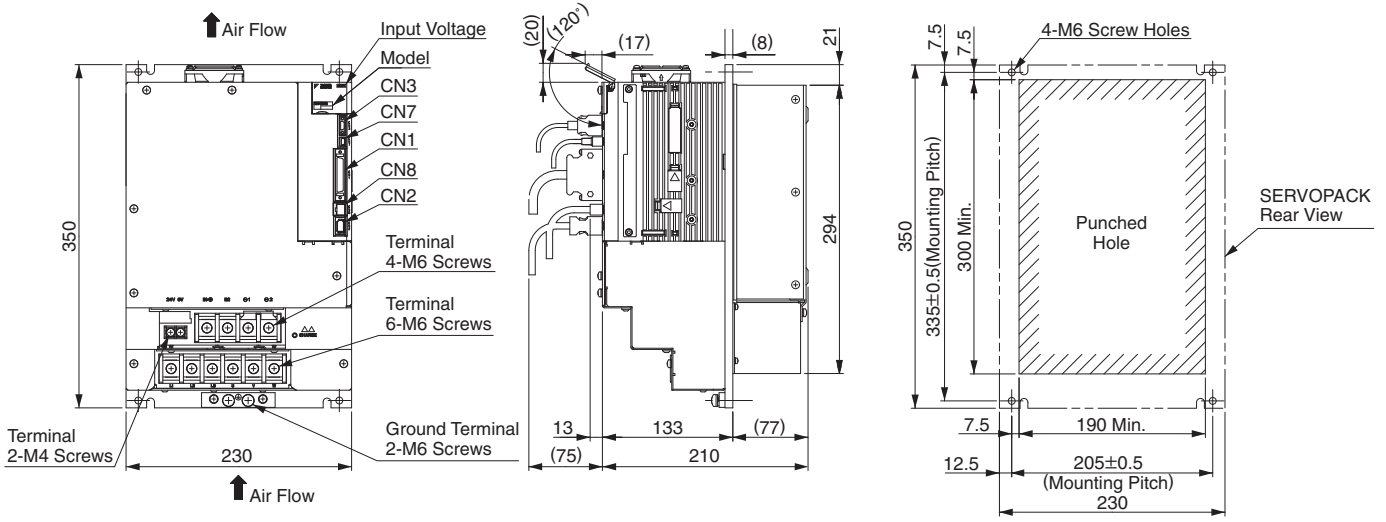

Mounting Hole Diagram

Approx. Mass: 8.1 kg

(15) Three-phase 400 VAC, Model: SGDV-280D0□A001 and -370D0□A001 (Duct-ventilated type)

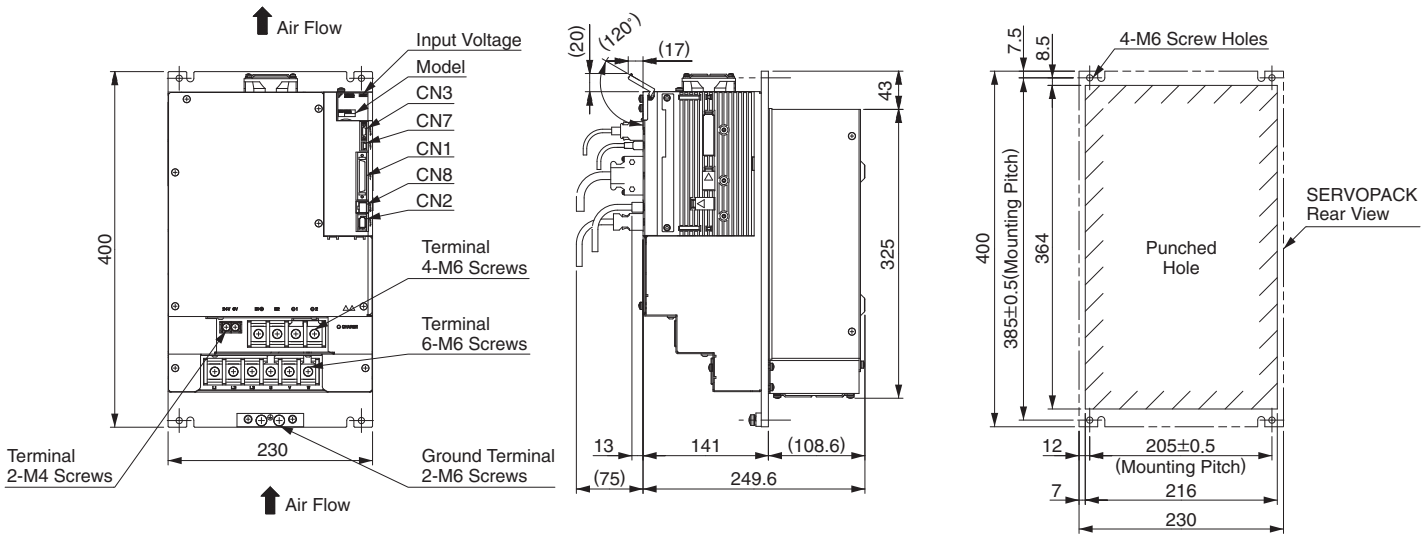

Mounting Hole Diagram

Approx. Mass: 13.6 kg

Connectors for Rack-mounted SERVOPACKs

Port	Model	Pin	Manufacturer
CN1	10250-52A2PL	50	Sumitomo 3M Ltd.
CN2	53984-0671	6	Molex Japan Co., Ltd.
CN3	HDR-EC14LFDFTN-SLE-PLUS	14	Honda Tsushin Kogyo Co., Ltd.
CN7	MNC23-5K5H00	5	ADVANCED-CONNECTEK INC.
CN8	1981080-1	8	Tyco Electronics AMP K.K.





Note: The connectors above or their equivalents are used for SERVOPACKs.

Analog/Pulse Type SERVOPACKs

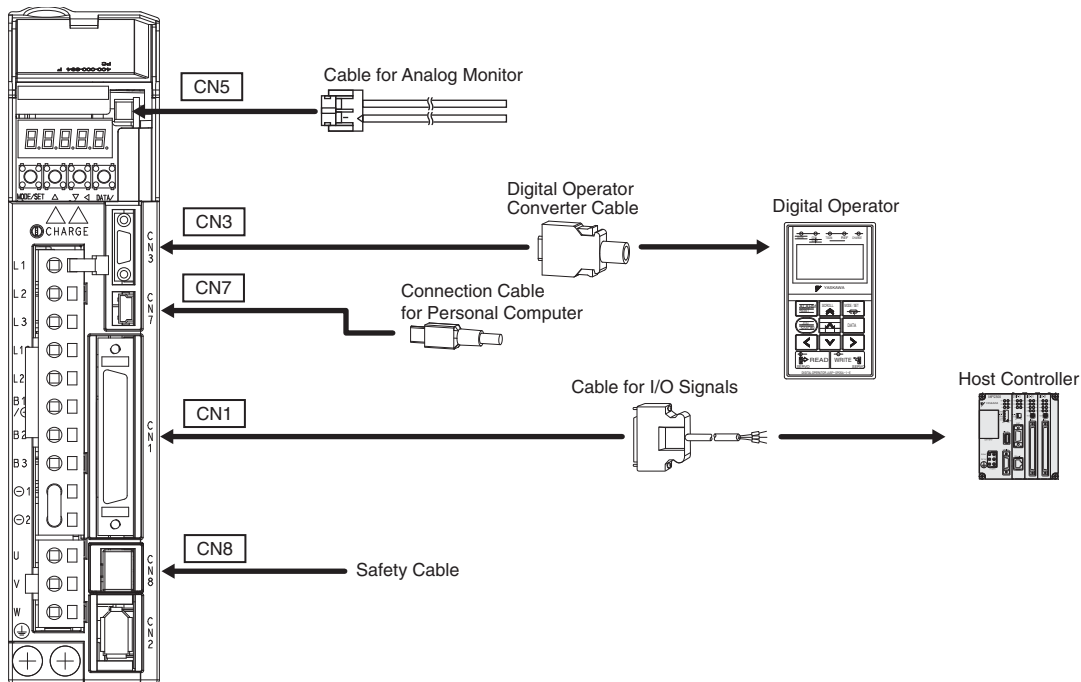
Selecting Cables

● Cables for **CN1** **CN3** **CN5** **CN7** **CN8** (Analog Voltage/Pulse Train Reference Type SERVOPACKs)

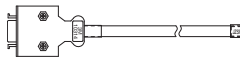

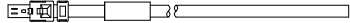
Name	Length	Order No.	Specifications	Details	
CN1 Cables for I/O Signals	Connector Terminal Converter Unit		JZSP-TA50PG-E	Terminal Block and 0.5 m Connection Cable 	(1)
	Cables with Loose Wires at One End	1 m	JZSP-CSI01-1-E	Cable with Loose Wires at Peripheral Devices 	(2)
		2 m	JZSP-CSI01-2-E		
CN3	Digital Operator		JZSP-OP05A-1-E	With Connection Cable (1 m) 	(3)
	Digital Operator Converter Cable*1	0.3 m	JZSP-CVS05-A3-E	Cable with Connectors at Both Ends 	(4)
CN7 Connection Cables for Personal Computer	2.5 m	JZSP-CVS06-02-E	Cable with Connectors at Both Ends 	(5)	
CN5 Cables for Analog Monitor	1 m	JZSP-CA01-E	SERVOPACK End 	(6)	
CN8 Cables for Safety Functions	Cables with Connector*2	3 m	JZSP-CVH03-03-E		(7)
	Connector Kit*3	Contact Tyco Electronics AMP K.K. Product name: Industrial Mini I/O D-shape Type1 Plug Connector Kit Model: 2013595-1			

*1 : A converter cable is required to use Σ -III series digital operators (model: JZSP-OP05A) for Σ -V series SERVOPACKs.

*2 : When using the safety function, connect this cable to the safety devices.

Even when not using the safety function, use SERVOPACKs with the Safe Jumper Connector (model: JZSP-CVH05-E) connected.

*3 : Use the connector kit when you make cables yourself.

Selecting Cables

(1) Connector Terminal Converter Unit for CN1

· Configurations

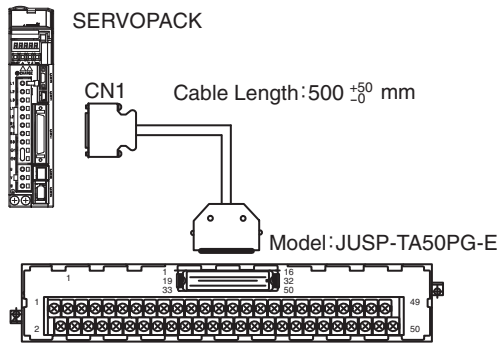

Model	Cable Length (L)
JUSP-TA50PG-E	0.5 m
JUSP-TA50PG-1-E	1 m
JUSP-TA50PG-2-E	2 m

· Dimensional Drawings of Terminal Block (Units: mm)

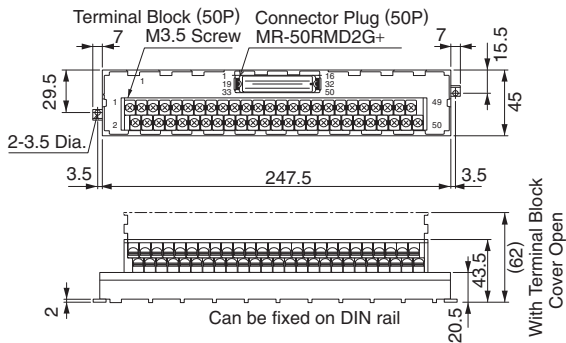

· Dimensional Drawings of Cable

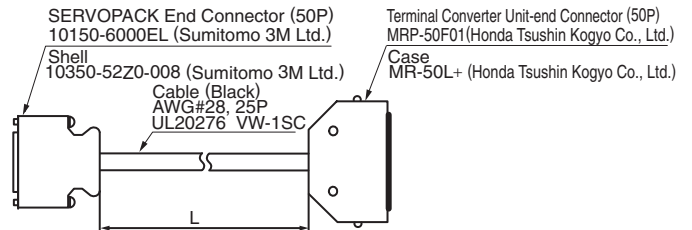

(2) Cable with Loose Wires at One End for CN1

· Dimensional Drawings of Cable

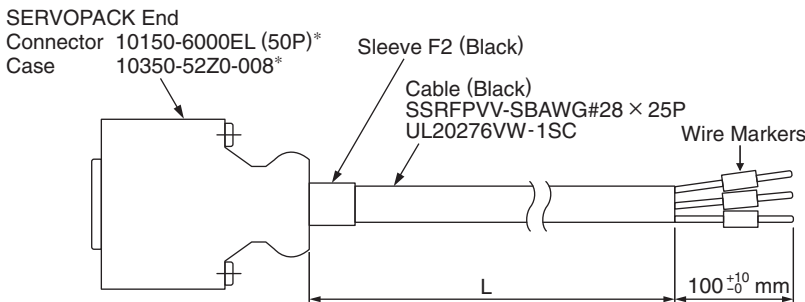

* : Manufactured by Sumitomo 3M Ltd.

Note : See the next page for the connection diagram.

Model	Cable Length (L)
JZSP-CSI01-1-E	1 m
JZSP-CSI01-2-E	2 m
JZSP-CSI01-3-E	3 m

Selecting Cables Units: mm

● Cable with Loose Wires at One End for CN1

Connection Diagram of JZSP-CSI01-□-E Cable

Pin No.	Signal	Wire Color	Marking		Lead Marker
			Color	Dots	
1	SG	Orange	Red	1	1
3	PL1	Orange	Black	1	3
2	SG	Gray	Red	1	2
4	SEN	Gray	Black	1	4
5	V-REF	White	Red	1	5
6	SG	White	Black	1	6
7	PULS	Yellow	Red	1	7
8	/PULS	Yellow	Black	1	8
9	T-REF	Pink	Red	1	9
10	SG	Pink	Black	1	10
11	SIGN	Orange	Red	2	11
12	/SIGN	Orange	Black	2	12
13	PL2	Gray	Red	2	13
14	/CLR	White	Red	2	14
15	CLR	White	Black	2	15
16	-	Gray	Black	2	16
17	-	Yellow	Red	2	17
18	PL3	Yellow	Black	2	18
19	PCO	Pink	Red	2	19
20	/PCO	Pink	Black	2	20
21	BAT(+)	Orange	Red	3	21
22	BAT(-)	Orange	Black	3	22
23	-	Gray	Red	3	23
24	-	Gray	Black	3	24
25	/V-CMP+	White	Red	3	25
26	/V-CMP-	White	Black	3	26
27	/TGON+	Yellow	Red	3	27
28	/TGON-	Yellow	Black	3	28
29	/S-RDY+	Pink	Red	3	29
30	/S-RDY-	Pink	Black	3	30
31	ALM+	Orange	Red	4	31
32	ALM-	Orange	Black	4	32
33	PAO	Gray	Red	4	33
34	/PAO	Gray	Black	4	34
35	PBO	White	Red	4	35
36	/PBO	White	Black	4	36
37	ALO1	Yellow	Red	4	37
38	ALO2	Yellow	Black	4	38
39	ALO3	Pink	Red	4	39
40	/S-ON	Pink	Black	4	40
41	/P-CON	Orange	Red	5	41
42	P-OT	Orange	Black	5	42
43	N-OT	Gray	Red	5	43
44	/ALM-RST	Gray	Black	5	44
45	/P-CL	White	Red	5	45
46	/N-CL	White	Black	5	46
47	+24V-IN	Yellow	Red	5	47
48	-	Pink	Red	5	48
49	-	Pink	Black	5	49
50	-	Yellow	Black	5	50
Case	Shield				

 Represents twisted-pair wires.

● Connector Kit for CN1

Use the following connector and cable to assemble the cable. The CN1 connector kit includes one case and one connector.

Connector Kit Model	Case		Connector	
	Model	Qty	Model	Qty
JZSP-CSI9-1-E	10350-52Z0-008*	1 set	10150-3000PE* (Soldered)	1

* : Manufactured by Sumitomo 3M Ltd.

· Dimensional Drawings of Case

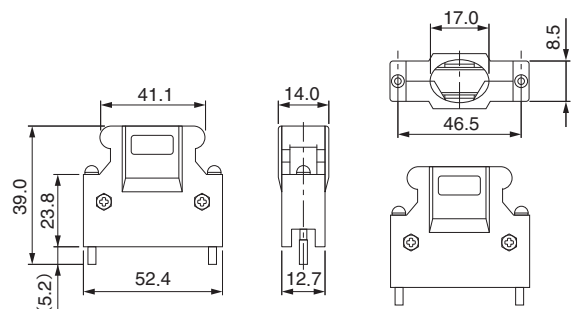

· Dimensional Drawings of Connector

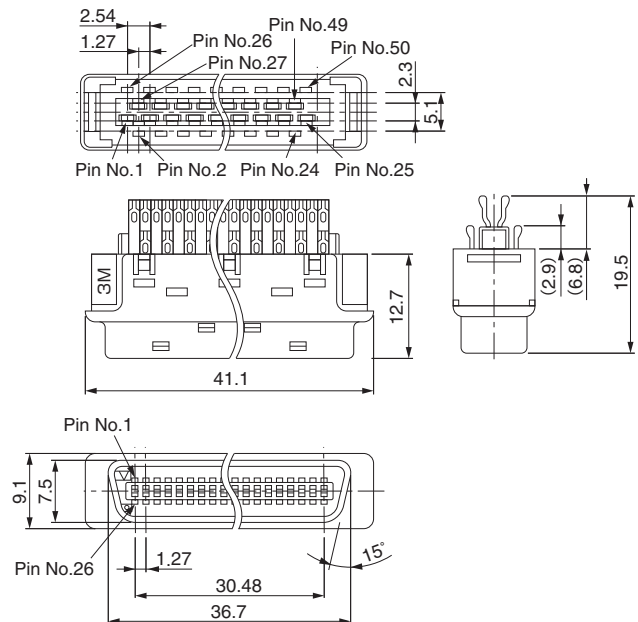

· Cable Size

Item	Specifications
Cable	Use twisted-pair or twisted-pair shielded wire.
Applicable Wires	AWG24, 26, 28, 30
Cable Finished Diameter	16 dia. max.

Selecting Cables Units: mm

(3) Digital Operator (Model: JUSP-OP05A-1-E)

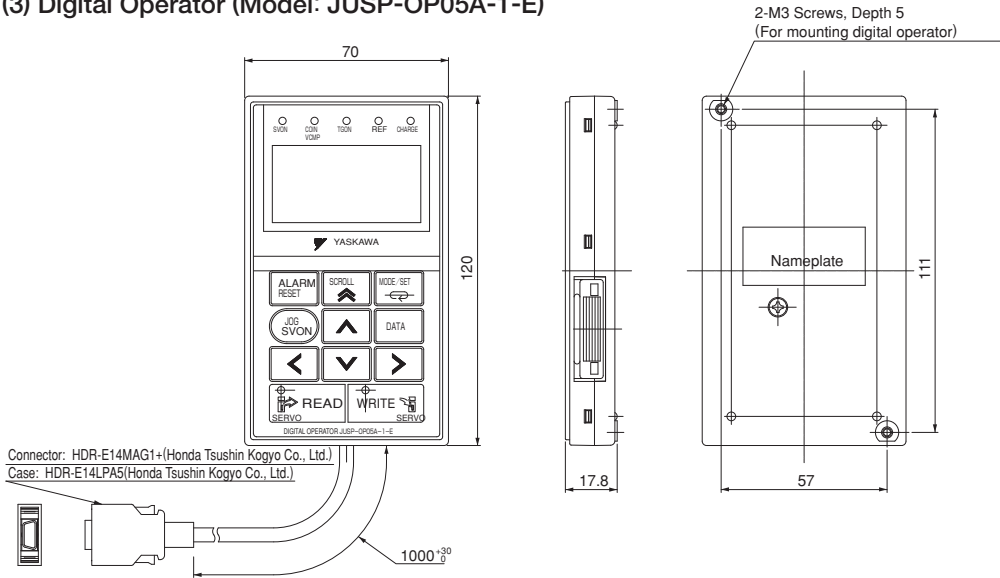

(4) Digital Operator Converter Cable for CN3 (Model: JZSP-CVS05-A3-E)

A converter cable is required to use Σ -III series digital operators (model: JUSP-OP05A) for Σ -V series SERVOPACKs.

· Dimensional Drawings

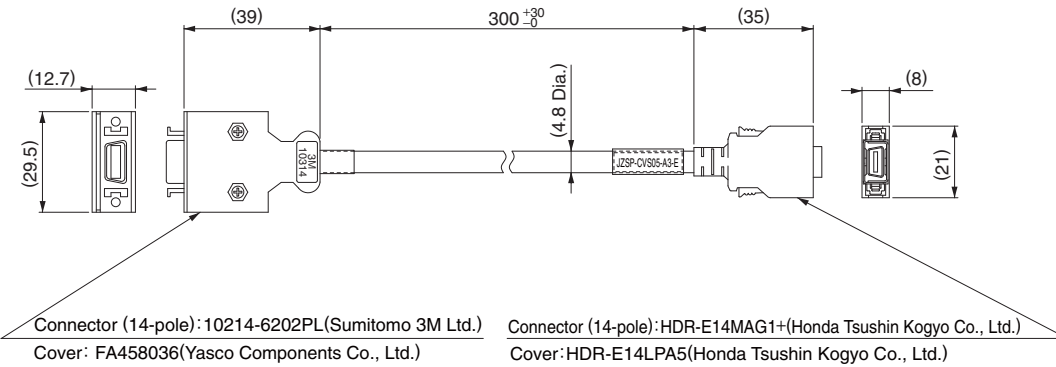

(5) Connection Cable for Personal Computer for CN7 (Model: JZSP-CVS06-02-E)

· Dimensional Drawings

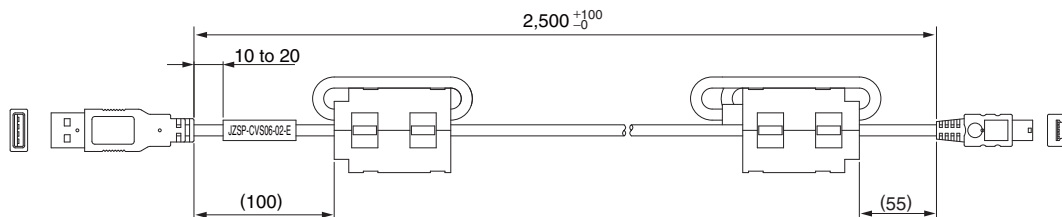

IMPORTANT Use a cable specified by Yaskawa.
 When using other cables, operation cannot be guaranteed.

Analog/Pulse Type SERVOPACKs

Selecting Cables Units: mm

(6) Cable for Analog Monitor for CN5 (Model: JZSP-CA01-E)

• Dimensional Drawings

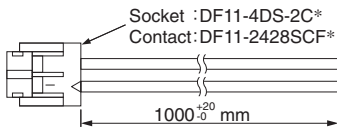

* : Manufactured by Hirose Electric Corporation.

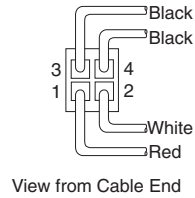

• Specifications

Pin No.	Cable Color	Signal	Standard Settings
1	Red	Analog Monitor 2	Motor speed : 1V/1000 min ⁻¹
2	White	Analog Monitor 1	Torque reference : 1V/100% rated torque
3, 4	Black (2 cables)	GND(0V)	—

Note : The specifications above are factory settings. Monitor specifications can be changed by changing parameters Pn006 and Pn007.

(7) Cable with Connector for CN8 (Model: JZSP-CVH03-03-E)

• Dimensional Drawings

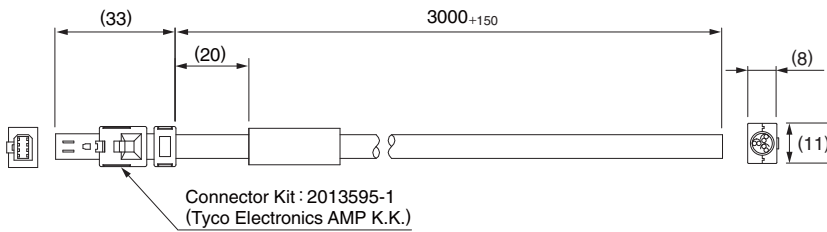

• Specifications

Pin No.	Signal	Lead Color	Marking Color
1	Not used	—	—
2	Not used	—	—
3	/HWBB1-	White	Black
4	/HWBB1+	White	Red
5	/HWBB2-	Gray	Black
6	/HWBB2+	Gray	Red
7	EDM1-	Orange	Black
8	EDM1+	Orange	Red

MECHATROLINK-II Communications Reference Type SERVOPACKs

SGDV-□□□□11 (For Rotary Servomotors)

SGDV-□□□□15 (For Linear Servomotors)



Model Designations

SGDV - R70 A 11 A □

Σ-V Series
SGDV SERVOPACK

Current

Voltage

Options

Code	Specifications
Blank	Base-mounted (standard)
001000	Rack-mounted*

*: SGD-470A, -550A, -590A, -780A, -210D, -260D, -280D, -370D SERVOPACKs are duct-ventilated.

Design Revision Order
A, B...

Interface

Code	Specifications
F	100 VAC
A	200 VAC
D	400 VAC

Code	Specifications
11	MECHATROLINK-II communications Reference Type (for rotary servomotors)
15	MECHATROLINK-II communications Reference Type (for linear servomotors)

Code	100 V		Code	200 V		Code	400 V	
	Applicable Servomotor Max. Capacity kW			Applicable Servomotor Max. Capacity kW			Applicable Servomotor Max. Capacity kW	
R70	0.05		R70	0.05		1R9	0.5	
R90	0.1		R90	0.1		3R5	1.0	
2R1	0.2		1R6	0.2		5R4	1.5	
2R8	0.4		2R8	0.4		8R4	2.0	
			3R8	0.5		120	3.0	
			5R5	0.75		170	5.0	
			7R6	1.0		210	6.0	
			120	1.5		260	7.5	
			180	2.0		280	11	
			200	3.0		370	15	
			330	5.0				
			470	6.0				
			550	7.5				
			590	11				
			780	15				

Features

- **Real-time communications**

MECHATROLINK-II communications enable high-speed control for 30 stations at a maximum transmission speed of 10 Mbps in a transmission cycle from 250 μ s to 4 ms (user setting). Such a high transmission speed allows real-time transmission of various data required for control.

- **Cost savings**

Thirty stations can be connected to a single MECHATROLINK-II transmission line, so wiring costs and time are greatly reduced. Also, only one signal connector is required on the host controller. And, the all-digital network eliminates the need for conversion from digital to analog for speed/torque references and for a pulse generator to generate position references.

- **High-precision motion control**

The SGD V SERVOPACK when connected to the host controller in the MECHATROLINK-II network provides not only torque, position, and speed control but also synchronized phase control that requires advanced control technology. The control mode can be changed online so that the machine can move smoothly in complex motions with great efficiency.

Ratings

Single-phase 100 V

SERVOPACK Model	SGDV-□□□□	R70F	R90F	2R1F	2R8F
Applicable Servomotor Max. Capacity	kW	0.05	0.1	0.2	0.4
Continuous Output Current	Arms	0.66	0.91	2.1	2.8
Max. Output Current	Arms	2.1	2.9	6.5	9.3
Main Circuit		Single-phase 100 to 115 VAC+10% to -15% 50/60 Hz			
Control Circuit		Single-phase 100 to 115 VAC+10% to -15% 50/60 Hz			

Three-phase 200 V

SERVOPACK Model	SGDV-□□□□	R70A	R90A	1R6A	2R8A	3R8A	5R5A	7R6A	120A	180A	200A	330A	470A	550A	590A	780A
Applicable Servomotor Max. Capacity	kW	0.05	0.1	0.2	0.4	0.5	0.75	1.0	1.5	2.0	3.0	5.0	6	7.5	11	15
Continuous Output Current	Arms	0.66	0.91	1.6	2.8	3.8	5.5	7.6	11.6	18.5	19.6	32.9	46.9	54.7	58.6	78
Max. Output Current	Arms	2.1	2.9	5.8	9.3	11	16.9	17	28	42	56	84	110	130	140	170
Main Circuit		Three-phase 200 to 230 VAC+10% to -15% 50/60 Hz														
Control Circuit		Single-phase 200 to 230 VAC+10% to -15% 50/60 Hz														

Three-phase 400 V

SERVOPACK Model	SGDV-□□□□	1R9D	3R5D	5R4D	8R4D	120D	170D	210D	260D	280D	370D
Applicable Servomotor Max. Capacity	kW	0.5	1.0	1.5	2.0	3.0	5.0	6	7.5	11	15
Continuous Output Current	Arms	1.9	3.5	5.4	8.4	11.9	16.5	20.8	25.7	28.1	37.2
Max. Output Current	Arms	5.5	8.5	14	20	28	42	55	65	70	85
Main Circuit		Three-phase 380 to 480 VAC+10% to -15% 50/60 Hz									
Control Circuit		24 VDC \pm 15%									

- **SERVOPACK Overload Characteristics**

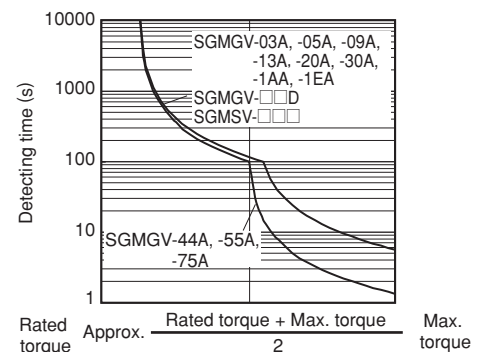
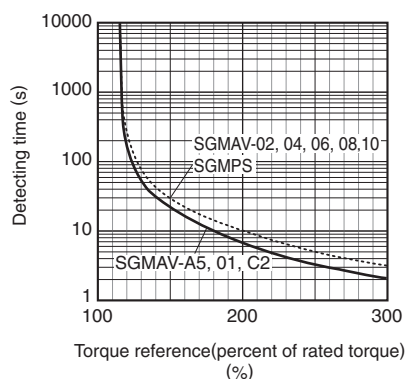
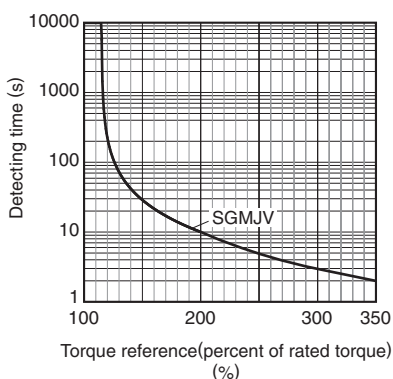

Note: Overload characteristics shown above do not guarantee continuous duty of 100% or more output. Use a servomotor with effective torque within the continuous duty zone of *Torque-Motor Speed Characteristics*.

Specifications

Items	Specifications	
Control Method	IGBT PWM control, sine-wave driven	
Feedback	Rotary Servomotors Serial encoder: 13-bit (incremental encoder) : 17-bit (incremental/absolute encoder) : 20-bit (incremental/absolute encoder)	
	With Linear Servomotors Serial converter unit or linear scale	
Operating Conditions	Surrounding Air/Storage Temperature Surrounding air temperature: 0 to +55°C, Storage temperature: -20 to +85°C	
	Ambient/Storage Humidity 90%RH or less (no condensation)	
	Vibration/Shock Resistance Vibration resistance: 4.9 m/s ² , Shock resistance: 19.6 m/s ²	
	Protection Class/Pollution Degree Protection class: IP10, pollution degree: 2 Do not use SERVOPACKs in the following locations: · Locations subject to corrosive or flammable gasses · Locations subject to exposure to water, oil, or chemicals · Locations subject to dust, including iron dust, and salts	
	Others Do not use SERVOPACKs in the following locations: · Locations subject to static electricity noise, strong electromagnetic/magnetic fields, radioactivity	
Altitude 1000 m or less		
Applicable Standards	UL508C EN50178, EN55011/A2 group1 classA, EN61000-6-2, EN61800-3, EN61800-5-1, EN954-1, IEC61508-1 to 4	
Configuration	Standard: Base-mounted Optional: Rack-mounted, Duct-ventilated	
Performance	Speed Control Range 1:5000 (The lowest speed of the speed control range is the speed at which the servomotor will not stop with a rated torque load.)	
	Speed Regulation*1	Load Fluctuation 0% to 100% load: ±0.01% max. (at rated speed)
		Voltage Fluctuation Rated voltage: ±10% : 0% (at rated speed)
		Temperature Fluctuation 25±25°C : ±0.1% max. (at rated speed)
	Torque Control Tolerance (Repeatability) ±1%	
Soft Start Time Setting 0 to 10 s (can be set individually for acceleration and deceleration.)		
Communications	RS-422A Communications	Interface Digital operator (JUSP-OP05A-1-E), personal computer (can be connected with SigmaWin+)
		1:N communications RS-422A port: N= 15 max. available
		Axis address setting Set by parameters
	USB Communications	Interface Personal computer (can be connected with SigmaWin+.)
Communications Standard Compliant with USB1.1 standard (12 Mbps)		
Display	CHARGE indicator	
Analog Monitor	Number of points: 2 Output voltage: ±10 VDC (linearity effective range ±8 V) Resolution: 16 bit Accuracy: ±20 mV (Typ) Max. output current: ±10 mA Settling time (±1%): 1.2 ms (Typ)	
Dynamic Brake (DB)	Activated when a servo alarm or overtravelling (OT) occurs, or when the power supply for the main circuit or servomotor is OFF.	
Protective Functions	Overcurrent, Overvoltage, low voltage, overload, regeneration error, etc.	
Utility Functions	Gain adjustment, alarm history, JOG operation, origin search, etc.	
Regenerative Processing	100 VAC model: External regenerative resistor (optional) 200 VAC SGDV-R70A, -R90A, -1R6A, -2R8A: External regenerative resistor (optional) 200 VAC SGDV-470A, -550A, -590A, -780A: External regenerative resistor unit (optional) 200 VAC models other than shown above: Built-in regenerative resistor 400 VAC SGDV-210D, -260D, -280D, -370D: External regenerative resistor unit (optional) 400 VAC models other than shown above: Built-in regenerative resistor	
Overtravelling (OT) Prevention	Dynamic brake stop at P-OT or N-OT, deceleration to a stop, or free run to a stop	
Safety Functions	Input /HWBB1, /HWBB2: Baseblock signal for power module	
	Output EDM1: Status monitor (fixed output) of built-in safety circuit	
	Applicable Standards*2 EN954 category 3, IEC61508 SIL2	
Option Module	Fully-closed option module	

*1: Speed regulation is defined as follows:

$$\text{Speed regulation} = \frac{\text{No-load motor speed} - \text{Total load motor speed}}{\text{Rated motor speed}} \times 100\%$$

The motor speed may change due to voltage fluctuation or temperature fluctuation.

The ratio of speed changes to the rated speed represent speed regulation due to voltage and temperature fluctuations.

*2: Perform risk assessment for the system and confirm that the safety requirements for the standards are fulfilled before using the HWBB function.

Specifications

● Rotary Servomotors

Items		Specifications		
I/O Signal	Encoder Output Pulses		Phase A, phase B, phase C: line driver output The number of dividing pulse: Any setting ratio is available.	
	Sequence Input	Fixed Input	SEN signal	
		Input Signals which can be allocated	Number of Channels	7 channels
	Function		Signal allocations and positive/negative logics can be modified. Homing deceleration switch signal (/DEC), external latch signal (/EXT1 to 3), forward run prohibited (P-OT), reverse run prohibited (N-OT), forward current limit (/P-CL), reverse current limit (/N-CL)	
	Sequence Output	Fixed Output	Servo alarm (ALM)	
		Output Signals which can be allocated	Number of Channels	3 channels
Function	Signal allocations and positive/negative logics can be modified. Positioning completion (/COIN), speed coincidence detection (/V-CMP), servomotor rotation detection (/TGON), servo ready (/S-RDY), torque limit detection (/CLT), speed limit detection (/VLT), brake (/BK), warning (/WARN), NEAR (/NEAR)			
Panel Operator		Display	7-segment 1-digit LED (red)	
		Switch	Rotary switch: 16 positions, DIP switch: 4 poles	
MECHATROLINK Communications		Communications Protocol	MECHATROLINK-II	
		Transmission Speed	10 Mbps	
		Transmission Cycle	250 μs, 0.5 to 4.0 ms (multiple of 0.5 ms)	
		Number of Words for Link Transmission	Can be switched between 17-bytes /station and 32-bytes / station.	
		Station Address	41H to 5FH (max. number of slaves: 30)	
Command Method		Performance	Position control, speed control, and torque control through MECHATROLINK communications	
		Command Input	MECHATROLINK commands (for sequence, motion, data setting/reference, monitor, adjustment, and other commands.)	

● Linear Servomotors

Items		Specifications		
I/O Signal	Encoder Output Pulses		Phase A, phase B, phase C: line driver output The number of dividing pulse: Any setting ratio is available.	
	Sequence Input	Fixed Input	SEN signal	
		Input Signals which can be allocated	Number of Channels	7 channels
	Function		Signal allocations and positive/negative logics can be modified. Homing deceleration switch signal (/DEC), external latch signal (/EXT1 to 3), forward run prohibited (P-OT), reverse run prohibited (N-OT), forward current limit (/P-CL), reverse current limit (/N-CL)	
	Sequence Output	Fixed Output	Servo alarm (ALM)	
		Output Signals which can be allocated	Number of Channels	3 channels
Function	Signal allocations and positive/negative logics can be modified. Positioning completion (/COIN), speed coincidence detection (/V-CMP), servomotor movement detection (/TGON), servo ready (/S-RDY), force limit detection (/CLT), speed limit detection (/VLT), brake (/BK), warning (/WARN), NEAR (/NEAR)			
Panel Operator		Display	7-segment 1-digit LED (red)	
		Switch	Rotary switch: 16 positions, piano switch: 4 poles	
MECHATROLINK Communications		Communications Protocol	MECHATROLINK-II	
		Transmission Speed	10 Mbps	
		Transmission Cycle	250 μs, 0.5 to 4.0 ms (multiple of 0.5 ms)	
		Number of Words for Link Transmission	Can be switched between 17-bytes /station and 32-bytes / station.	
		Station Address	41H to 5FH (max. number of slaves: 30)	
Command Method		Performance	Position control, speed control, and force control through MECHATROLINK-II communications	
		Command Input	MECHATROLINK commands and MECHATROLINK-II commands (for sequence, motion, data setting/reference, monitor, adjustment, and other commands.)	

Power Supply Capacities and Power Losses

The following table shows SERVOPACK's power supply capacities and power losses at the rated output.

Main Circuit Power Supply	Applicable Servomotor Max. Capacity kW	SERVOPACK Model SGD V-	Power Supply Capacity kVA	Output Current Arms	Main Circuit Power Loss W	Regenerative Resistor Power Loss	Control Circuit Power Loss W	Total Power Loss W		
						W				
Signal-phase 100 V	0.05	R70F	0.2	0.66	5.4	—	17	22.4		
	0.1	R90F	0.3	0.91	7.8			24.8		
	0.2	2R1F	0.7	2.1	14.4			31.4		
	0.4	2R8F	1.4	2.8	25.6			42.6		
Single-phase 200 V	0.05	R70A	0.2	0.66	5.2	—	17	22.2		
	0.1	R90A	0.3	0.91	7.4			24.4		
	0.2	1R6A	0.7	1.6	13.7			30.7		
	0.4	2R8A	1.2	2.8	24.9			41.9		
	0.75	5R5A	1.9	5.5	52.7			8	77.7	
	1.5	120A	4	11.6	68.2	10	22	100.2		
Three-phase 200 V	0.05	R70A	0.2	0.66	5.1	—	17	22.1		
	0.1	R90A	0.3	0.91	7.3			24.3		
	0.2	1R6A	0.6	1.6	13.5			30.5		
	0.4	2R8A	1	2.8	24.0			41.0		
	0.5	3R8A	1.4	3.8	20.1			45.1		
	0.75	5R5A	1.6	5.5	43.8	8	68.8			
	1.0	7R6A	2.3	7.6	53.6	10	22	78.6		
	1.5	120A	3.2	11.6	65.8			97.8		
	2.0	180A	4	18.5	111.9	16	27	149.9		
	3.0	200A	5.9	19.6	113.8			161.4		
	5.0	330A	7.5	32.9	263.7			36	326.7	
	6.0	470A	10.7	46.9	279.4	(180)*1	33	312.4		
	7.5	550A	14.6	54.7	357.8	(350)*2		390.8		
	11	590A	21.7	58.6	431.7	48	48	479.7		
	15	780A	29.6	78	599.0			647.0		
Three-phase 400 V	0.5	1R9D	1.1	1.9	24.6	14	21	59.6		
	1.0	3R5D	2.3	3.5	46.1			81.1		
	1.5	5R4D	3.5	5.4	71.3			106.3		
	2.0	8R4D	4.5	8.4	77.9	28	25	130.9		
	3.0	120D	7.1	11.9	108.7			161.7		
	5.0	170D	11.7	16.5	161.1	36	24	221.1		
	6.0	210D	12.4	20.8	172.7			(180)*3	27	199.7
	7.5	260D	14.4	25.7	218.6					245.6
	11	280D	21.9	28.1	294.6	(350)*4	30	324.6		
15	370D	30.6	37.2	403.8	433.8					

*1: For the optional JUSP-RA04-E regenerative resistor unit.

*2: For the optional JUSP-RA05-E regenerative resistor unit.

*3: For the optional JUSP-RA18-E regenerative resistor unit.

*4: For the optional JUSP-RA19-E regenerative resistor unit.

Notes: 1 SGD V-R70F, -R90F, -2R1F, -2R8F, -R70A, -R90A, -1R6A, and -2R8A SERVOPACKs do not have built-in regenerative resistors.

If the regenerative energy exceeds the specified value, connect an external regenerative resistor (optional).

2 SGD V-470A, -550A, -590A, -780A, -210D, -260D, -280D, -370D SERVOPACKs do not have built-in regenerative resistors.

Be sure to connect a regenerative resistor unit (optional) or an external regenerative resistor (optional). For selection details, refer to page 360.

3 Regenerative resistor power losses are allowable losses. Take the following action if this value is exceeded.

- Remove the lead or short bar that is short-circuiting the SERVOPACK main circuit terminal B2 and B3.

- (SGDV-3R8A, -5R5A, -7R6A, -120A, -180A, -200A, -330A, or 400-V class SERVOPACKs.)

- Install an external regenerative resistor (optional). For selection details, refer to page 360.

External Dimensions Units: mm

● **Base-mounted SERVOPACKs**

(1) Single-phase 100 VAC, Model: SGDV-R70F1□A, -R90F1□A, and -2R1F1□A

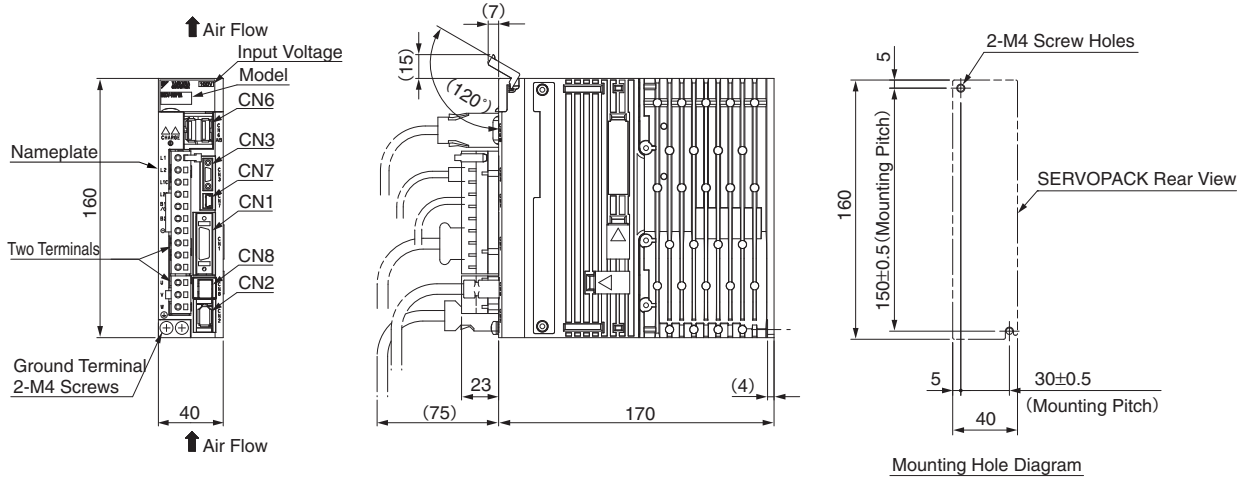

Approx. Mass: 1.0 kg

(2) Single-phase 100 VAC, Model: SGDV-2R8F1□A

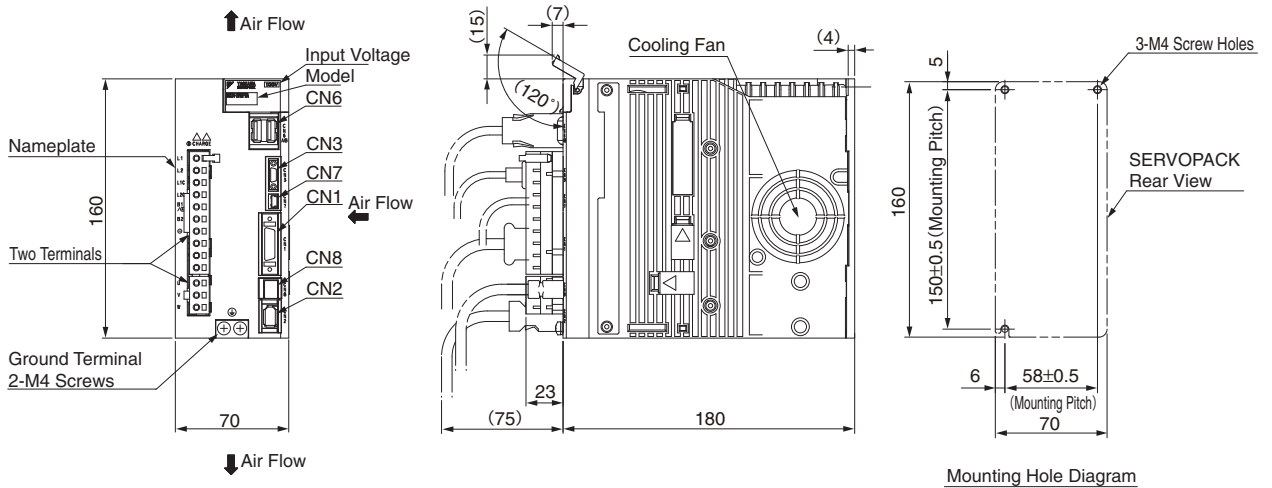

Approx. Mass: 1.5 kg

(3) Three-phase 200 VAC, Model: SGDV-R70A1□A, -R90A1□A, and -1R6A1□A

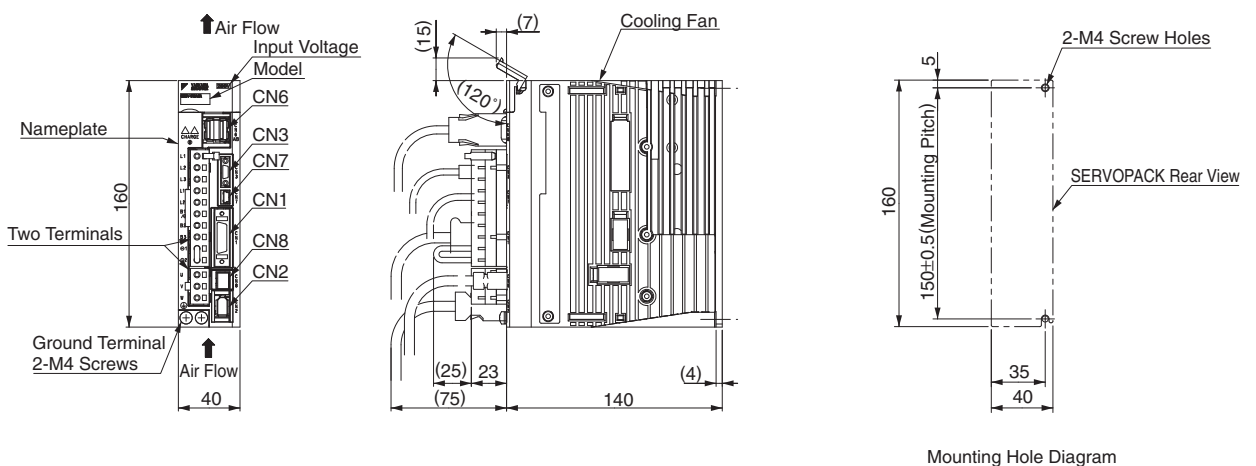

Approx. Mass: 0.9 kg

M-II Type SERVOPACKs

External Dimensions Units: mm

(4) Three-phase 200 VAC, Model: SGDV-2R8A1□A

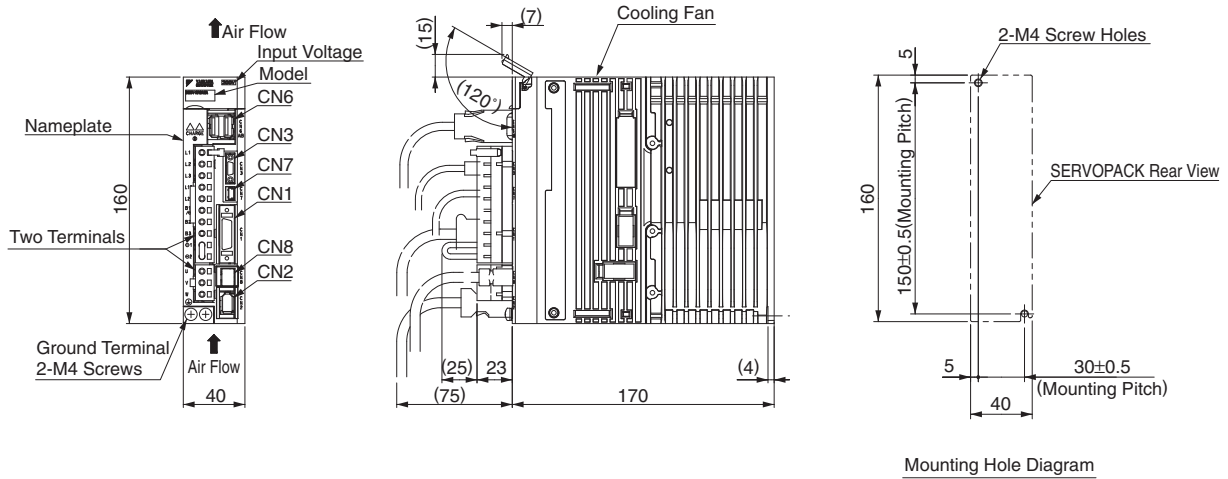

Approx. Mass: 1.0 kg

(5) Three-phase 200 VAC, Model: SGDV-3R8A1□A, -5R5A1□A, and -7R6A1□A

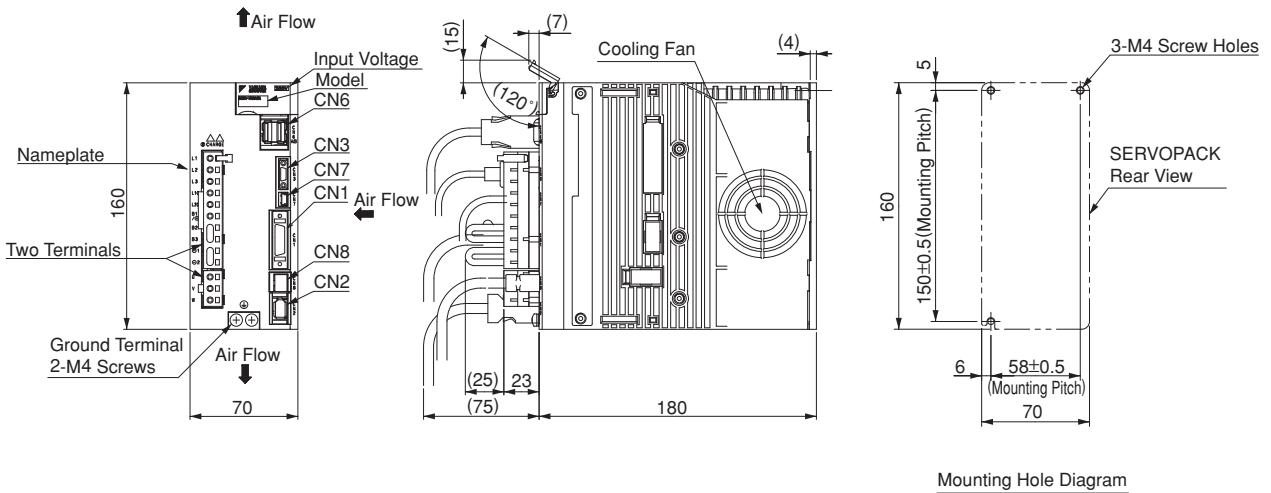

Approx. Mass: 1.5 kg

(6) Three-phase 200 VAC, Model: SGDV-120A1□A

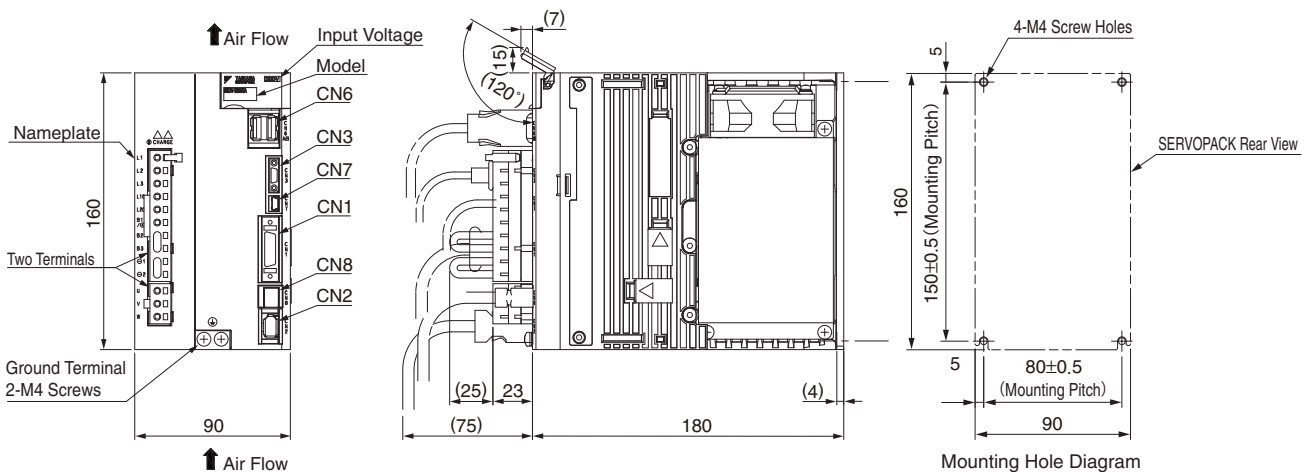

Approx. Mass: 2.4 kg

External Dimensions Units: mm

(7) Single-phase 200 VAC, Model: SGDV-120A1□A008000 (1.5 kW, single-phase input type)
 Three-phase 200 VAC, Model: SGDV-180A1□A and -200A1□A

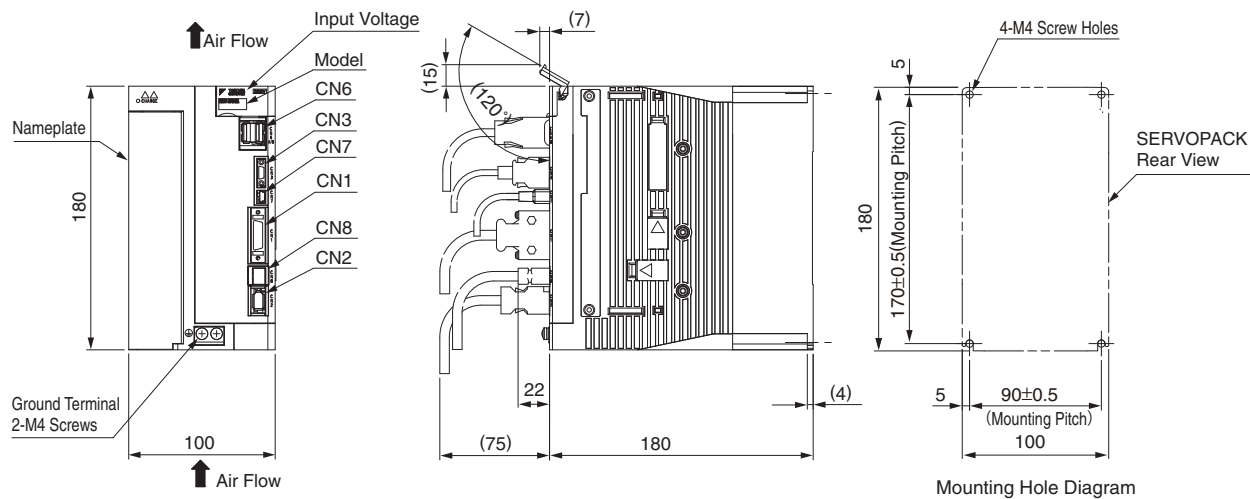

Mounting Hole Diagram
 Approx. Mass: 2.8 kg

(8) Three-phase 200 VAC, Model: SGDV-330A1□A

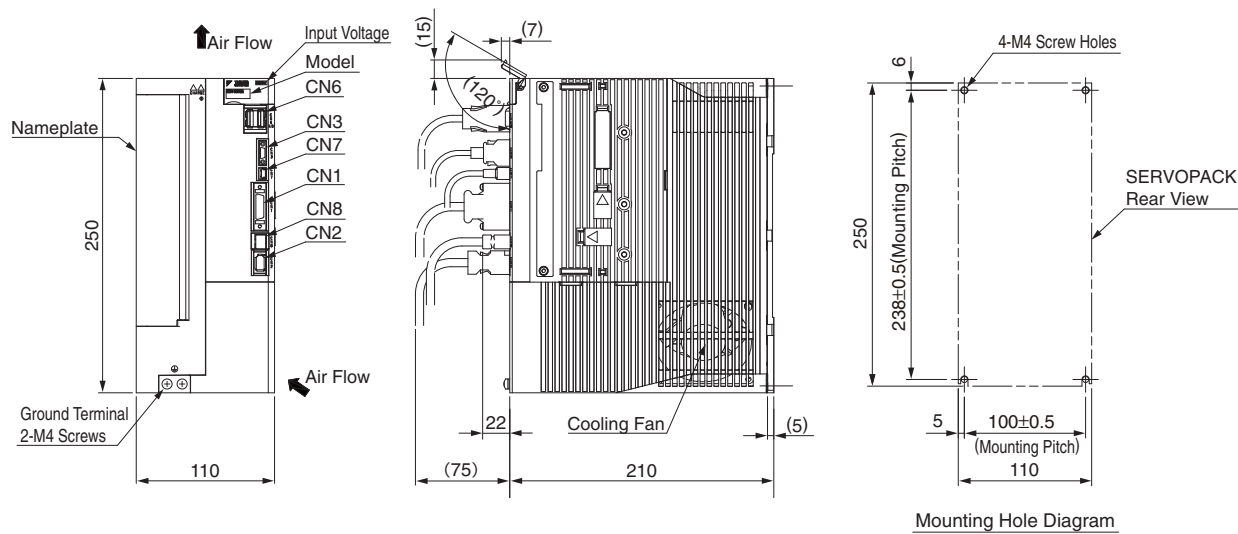

Mounting Hole Diagram
 Approx. Mass: 4.6 kg

External Dimensions Units: mm

(9) Three-phase 200 VAC, Model: SGDV-470A1□A and -550A1□A

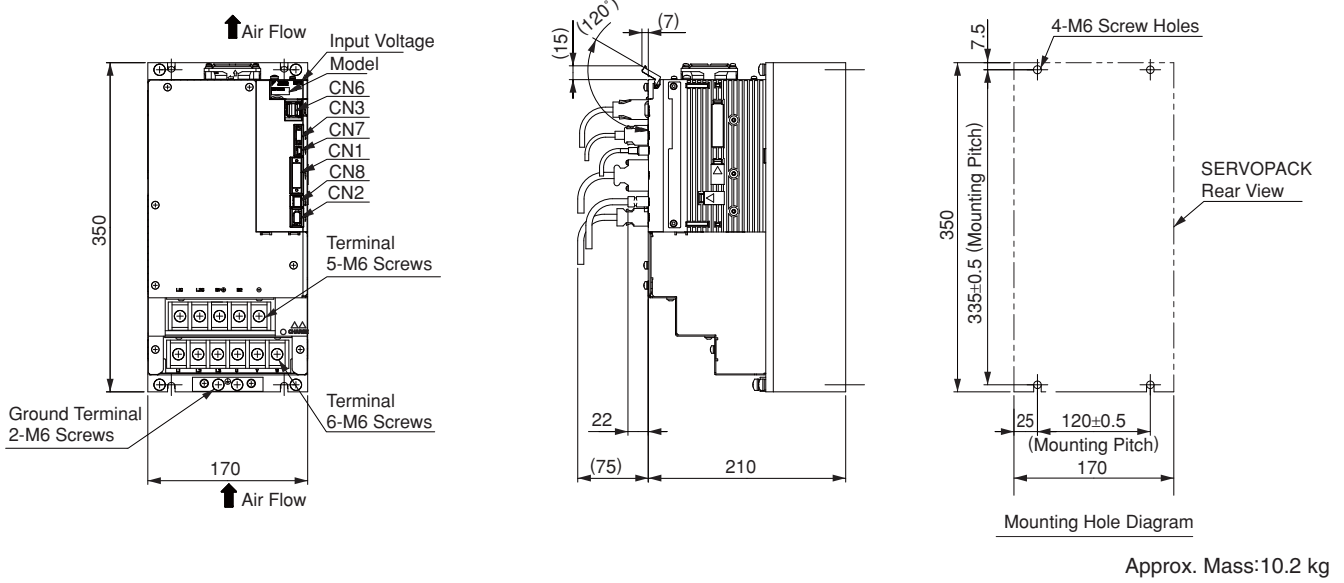

(10) Three-phase 200 VAC, Model: SGDV-590A1□A and -780A1□A

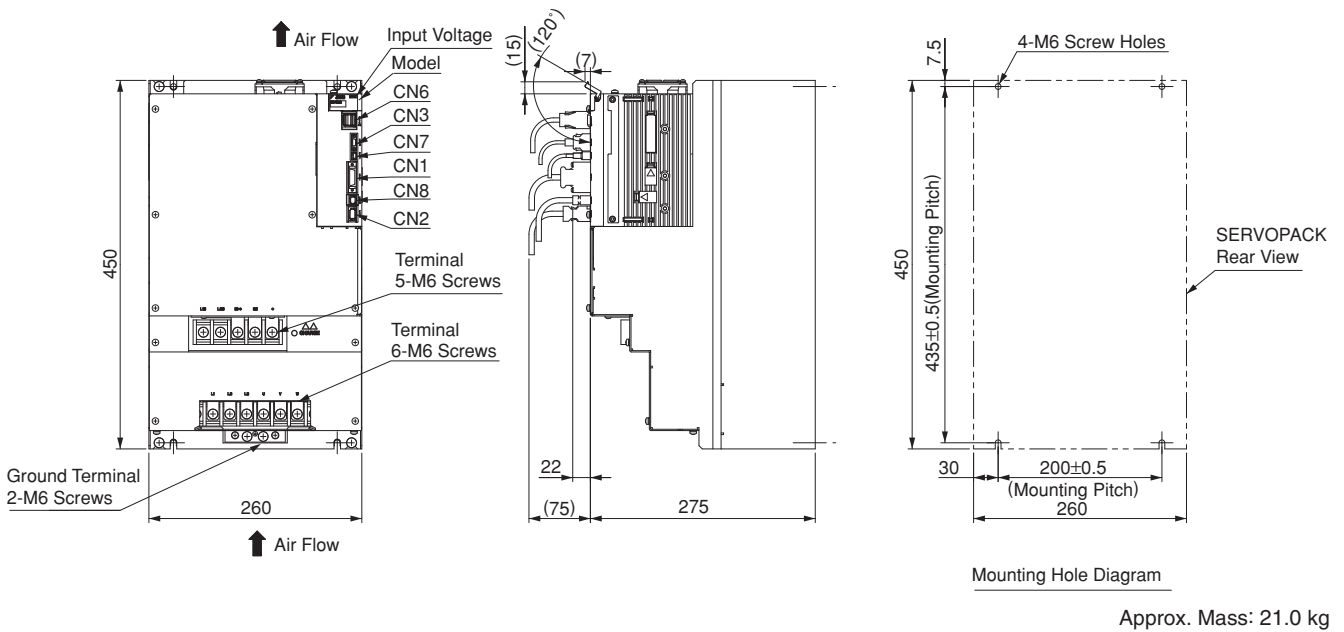

External Dimensions Units: mm

(11) Three-phase 400 VAC, Model: SGDV-1R9D1□A, -3R5D1□A, and -5R4D1□A

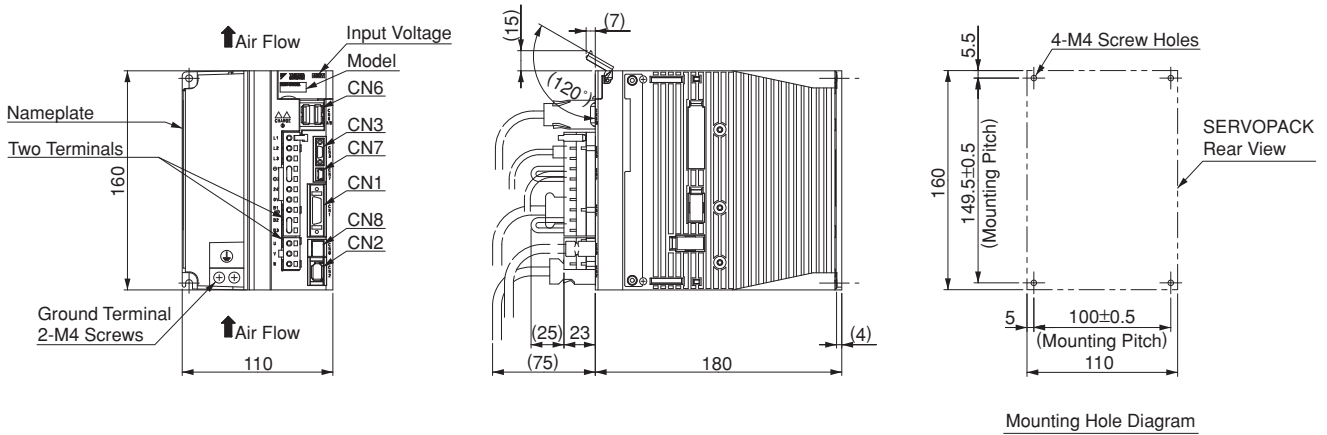

Mounting Hole Diagram

Approx. Mass: 2.7 kg

(12) Three-phase 400 VAC, Model: SGDV-8R4D1□A, and -120D1□A

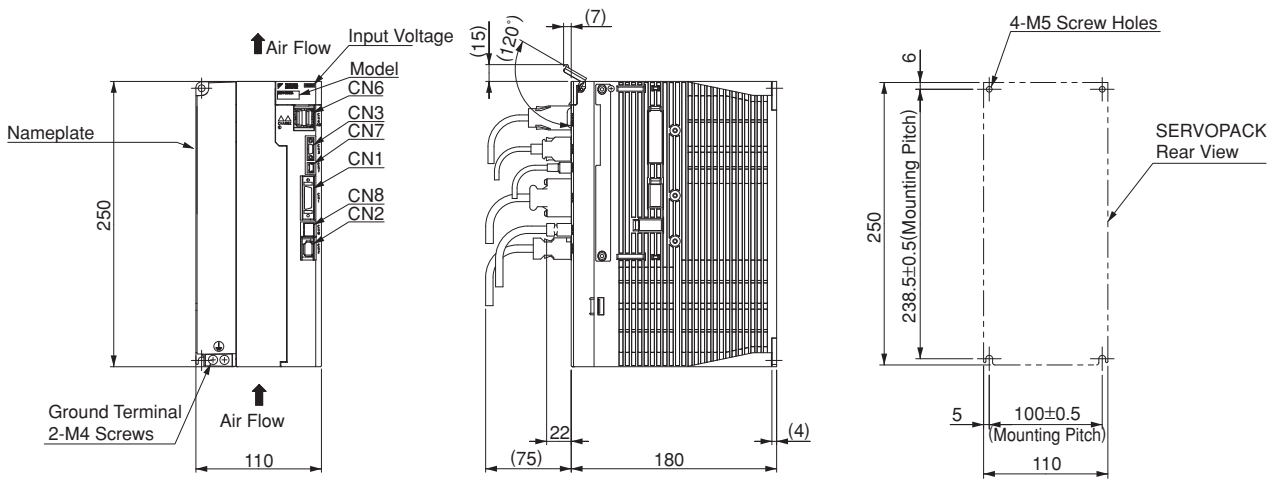

Mounting Hole Diagram

Approx. Mass: 3.7 kg

(13) Three-phase 400 VAC, Model: SGDV-170D1□A

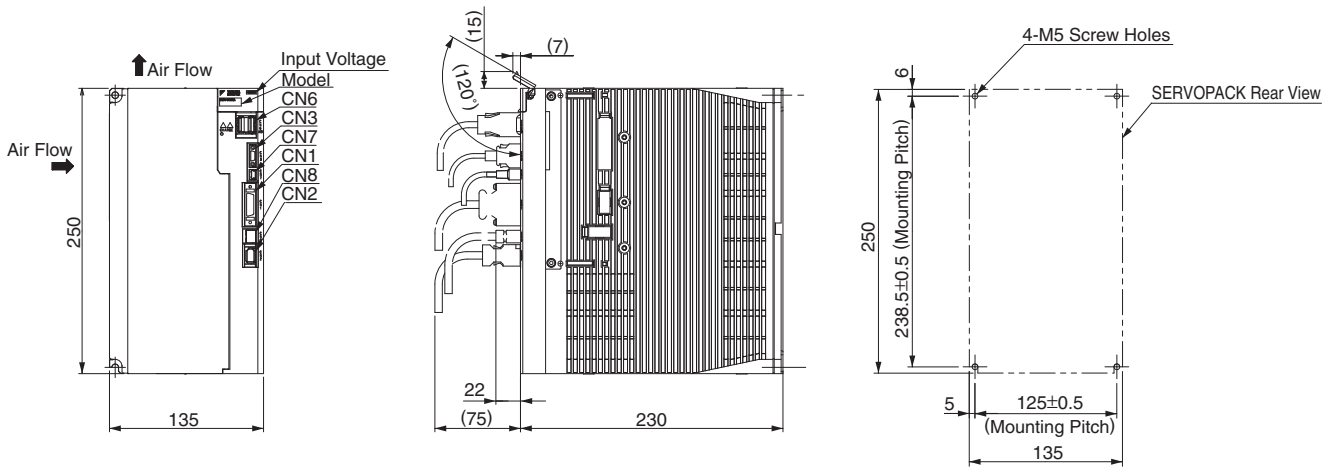

Mounting Hole Diagram

Approx. Mass: 5.6 kg

External Dimensions Units: mm

(14) Three-phase 400 VAC, Model: SGD V-210D1□A and -260D1□A

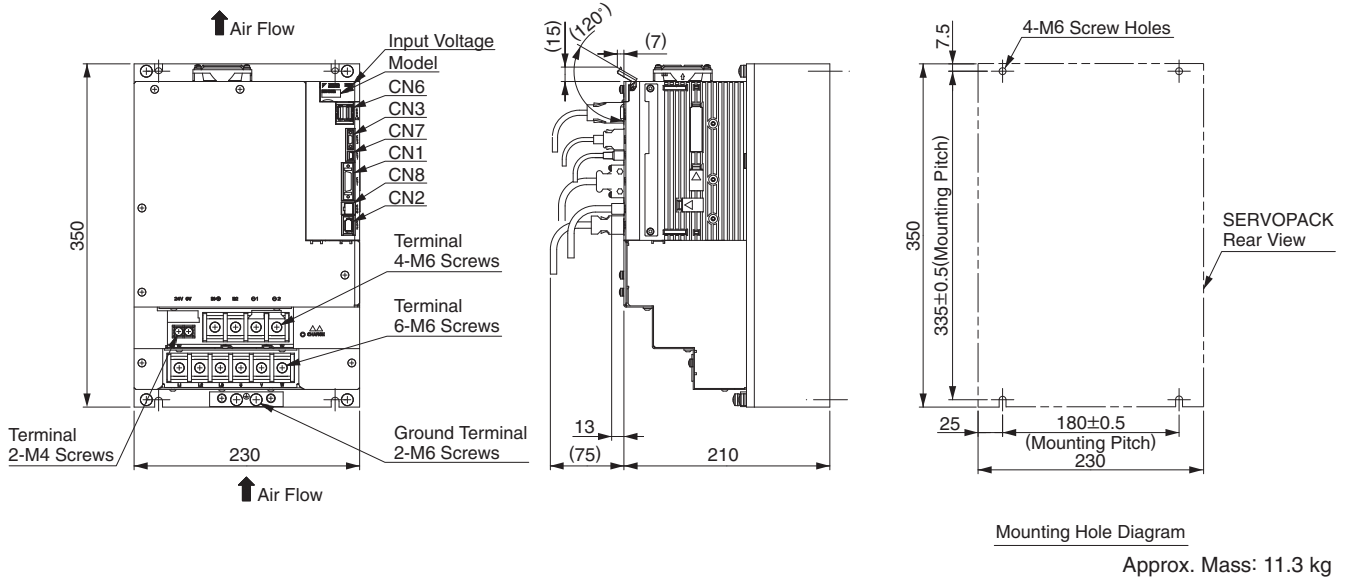

(15) Three-phase 400 VAC, Model: SGD V-280D1□A and -370D1□A

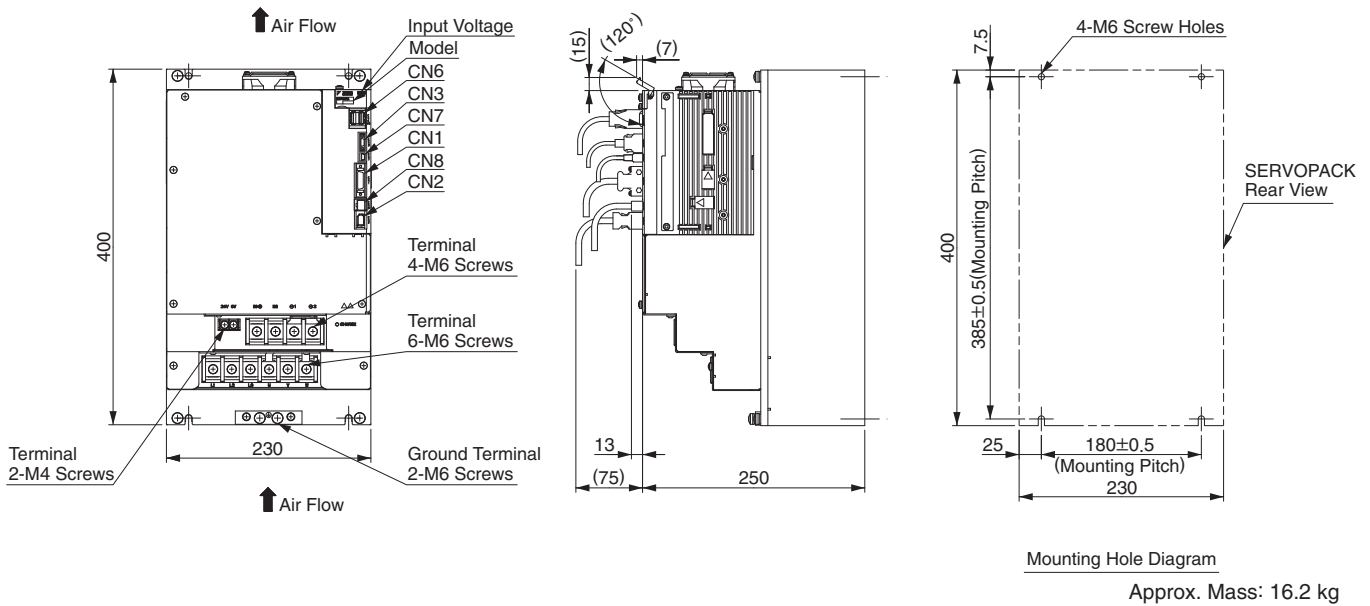

Connectors for Base-mounted SERVOPACKS

Port	Model	Pin	Manufacturer
CN1	10226-52A2PL	26	Sumitomo 3M Ltd.
CN2	53984-0671	6	Molex Japan Co., Ltd.
CN3	HDR-EC14LFD TN-SLE-PLUS	14	Honda Tsushin Kogyo Co., Ltd.
CN6	1903815-1	8	Tyco Electronics AMP K.K.
CN7	MNC23-5K5H00	5	ADVANCED-CONNECTEK INC.
CN8	1981080-1	8	Tyco Electronics AMP K.K.

Note: The connectors above or their equivalents are used for SERVOPACKS.

External Dimensions Units: mm

● **Rack-mounted SERVOPACKs (6 kW or more models: duct-ventilated)**

(1) Single-phase 100 VAC, Model: SGDV-R70F1□A001, -R90F1□A001, and -2R1F1□A001

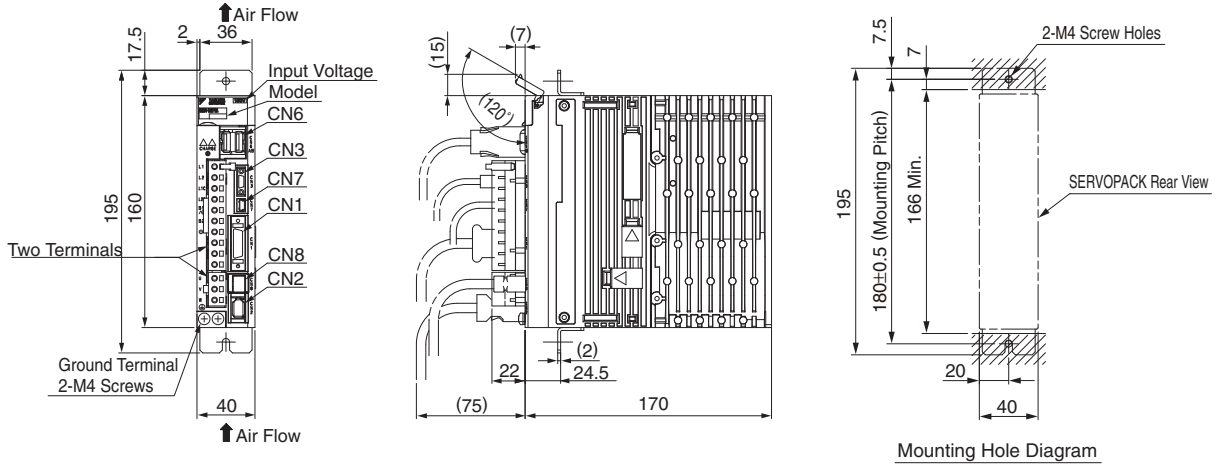

Mounting Hole Diagram

Approx. Mass: 1.1 kg

(2) Single-phase 100 VAC, Model: SGDV-2R8F1□A001

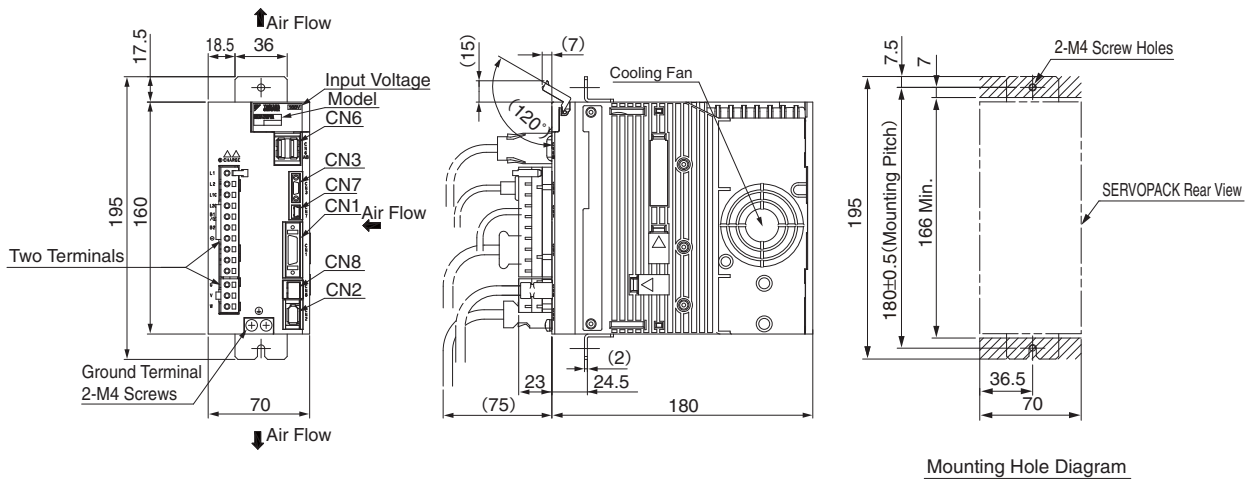

Mounting Hole Diagram

Approx. Mass: 1.5 kg

(3) Three-phase 200 VAC, Model: SGDV-R70A1□A001, -R90A1□A001, and -1R6A1□A001

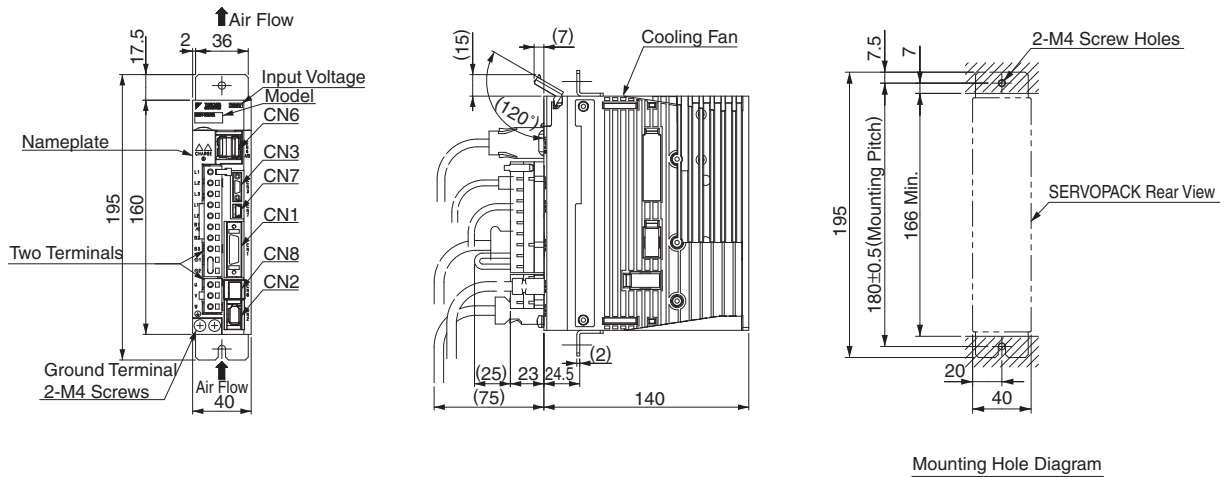

Mounting Hole Diagram

Approx. Mass: 0.9 kg

External Dimensions Units: mm

(4) Three-phase 200 VAC, Model: SGDV-2R8A1□A001

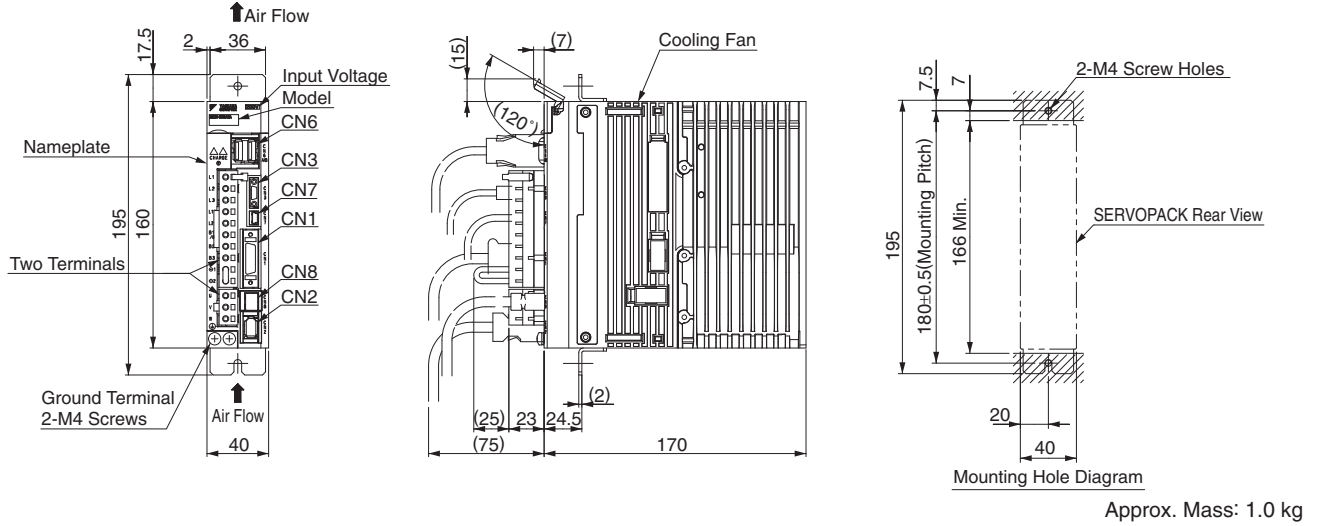

(5) Three-phase 200 VAC, Model: SGDV-3R8A1□A001, -5R5A1□A001, and -7R6A1□A001

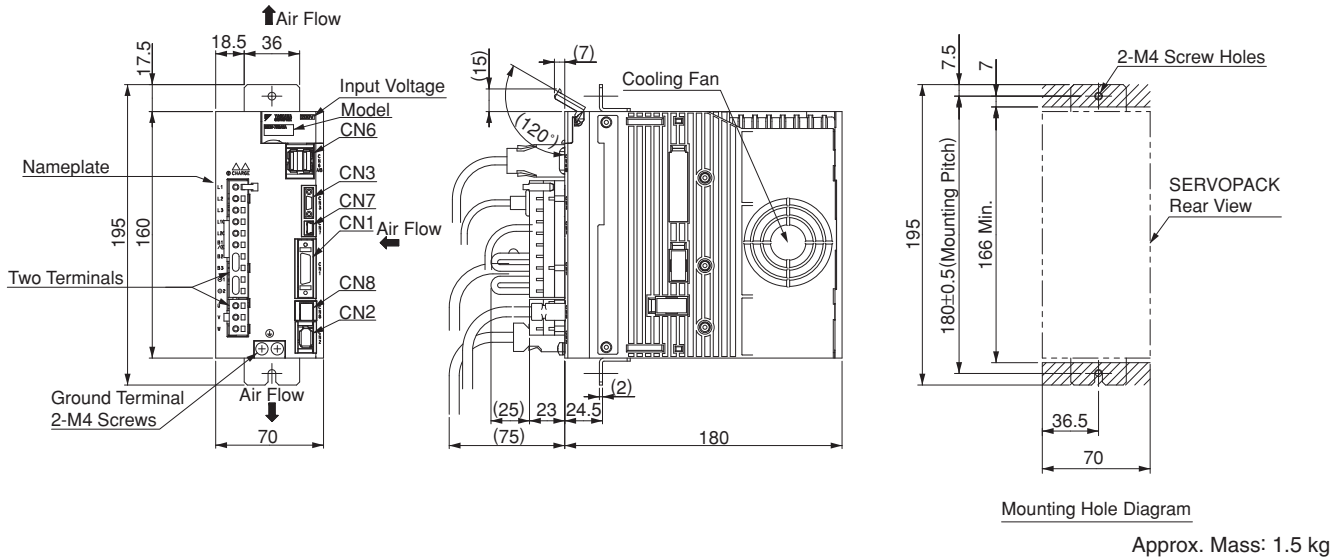

(6) Three-phase 200 VAC, Model: SGDV-120A1□A001

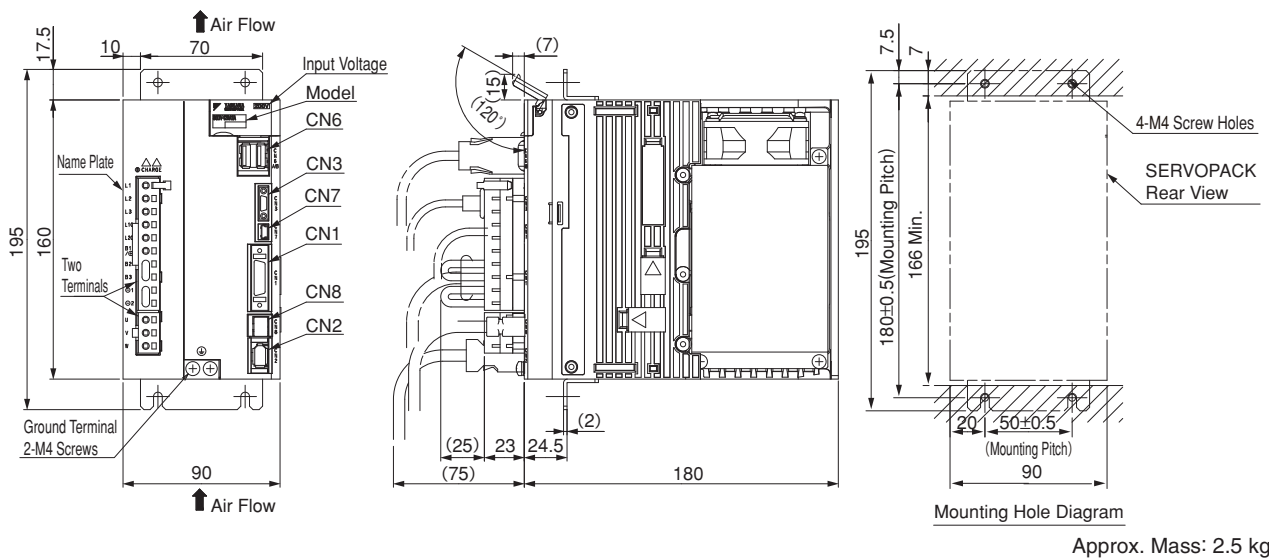

External Dimensions Units: mm

(7) Shingle-phase 200 VAC, Model: SGDV-120A1□A009000 (1.5 kW, single-phase input type)
 Three-phase 200 VAC, Model: SGDV-180A1□A001 and -200A1□A001

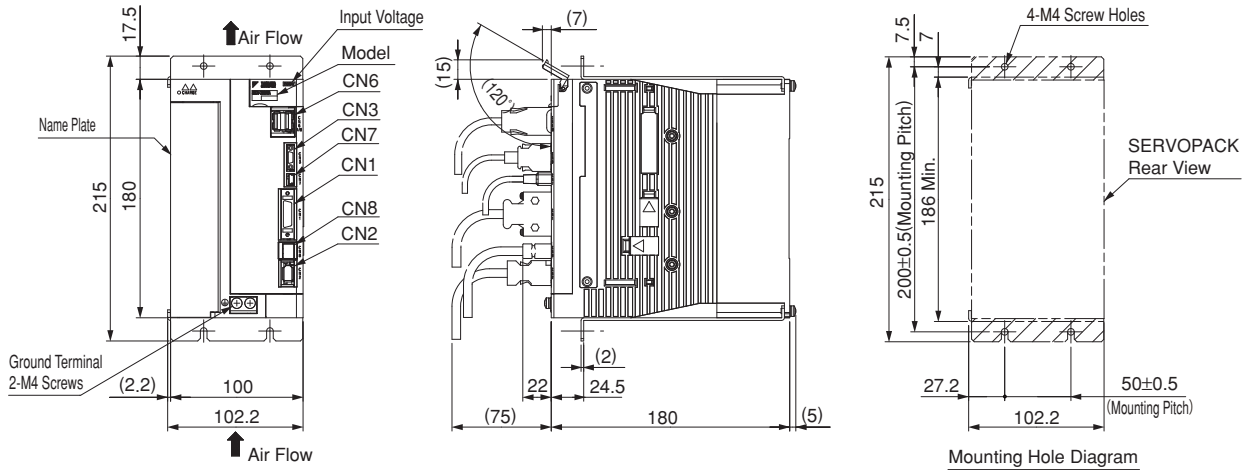

Approx. Mass: 3.1 kg

(8) Three-phase 200 VAC, Model: SGDV-330A1□A001

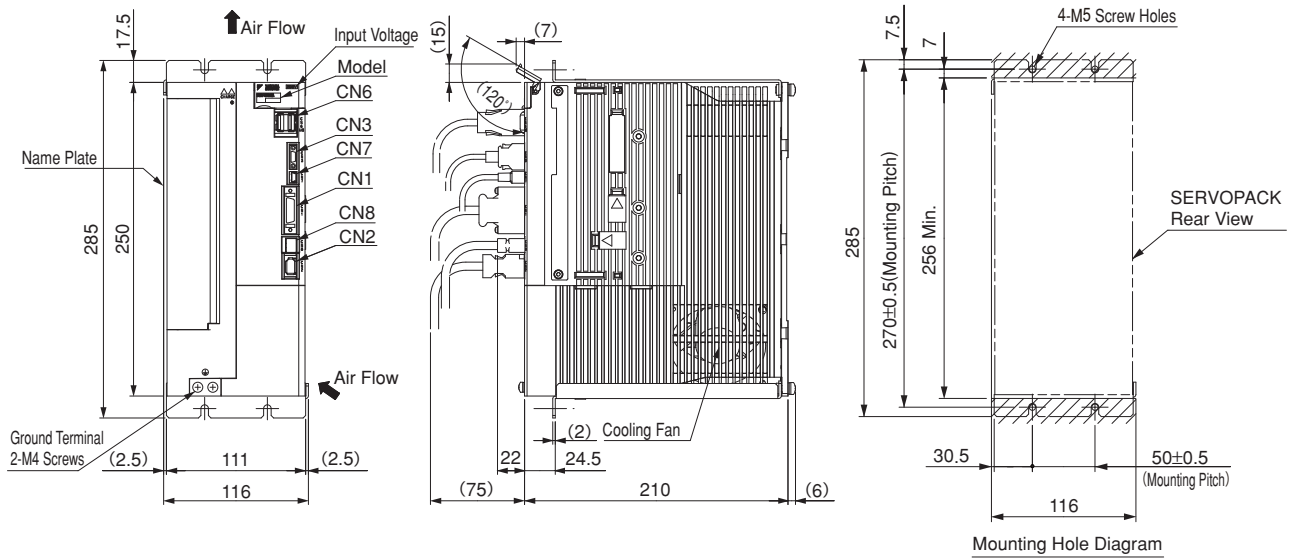

Approx. Mass: 5.0 kg

M-II Type SERVOPACKs

External Dimensions Units: mm

(9) Three-phase 200 VAC, Model: SGDV-470A1□A001 and -550A1□A001 (Duct-ventilated type)

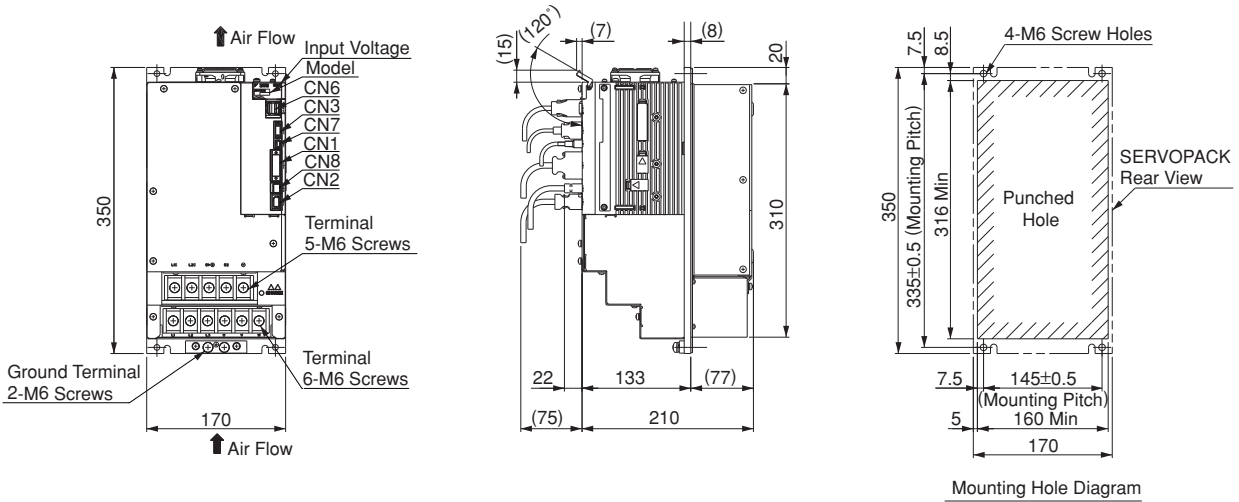

Approx. Mass: 8.5 kg

(10) Three-phase 200 VAC, Model: SGDV-580A1□A001 and -780A1□A001 (Duct-ventilated type)

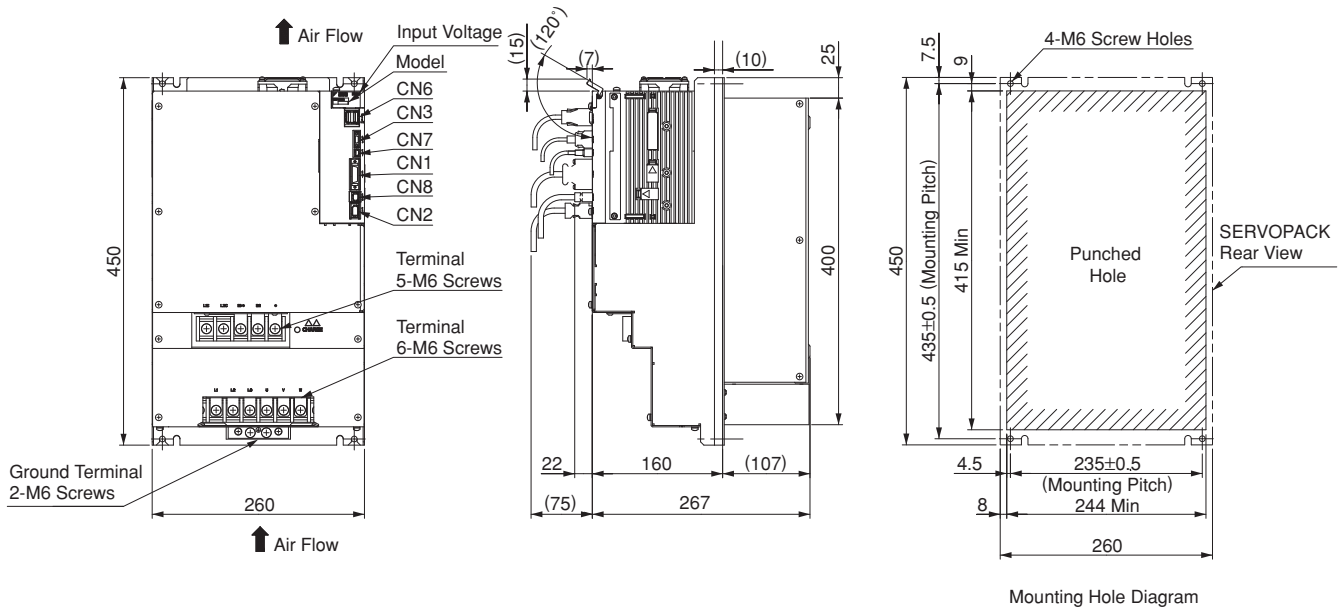

Approx. Mass: 16.0 kg

External Dimensions Units: mm

(11) Three-phase 400 VAC, Model: SGD1-1R9D1□A001, -3R5D1□A001, and -5R4D1□A001

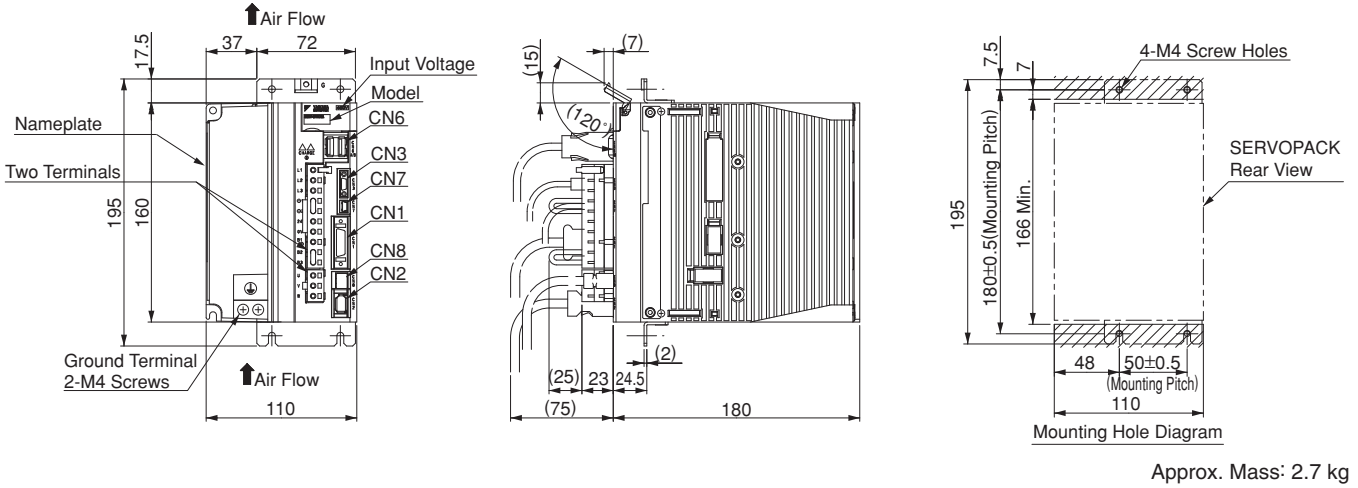

(12) Three-phase 400 VAC, Model: SGD1-8R4D1□A001 and -120D1□A001

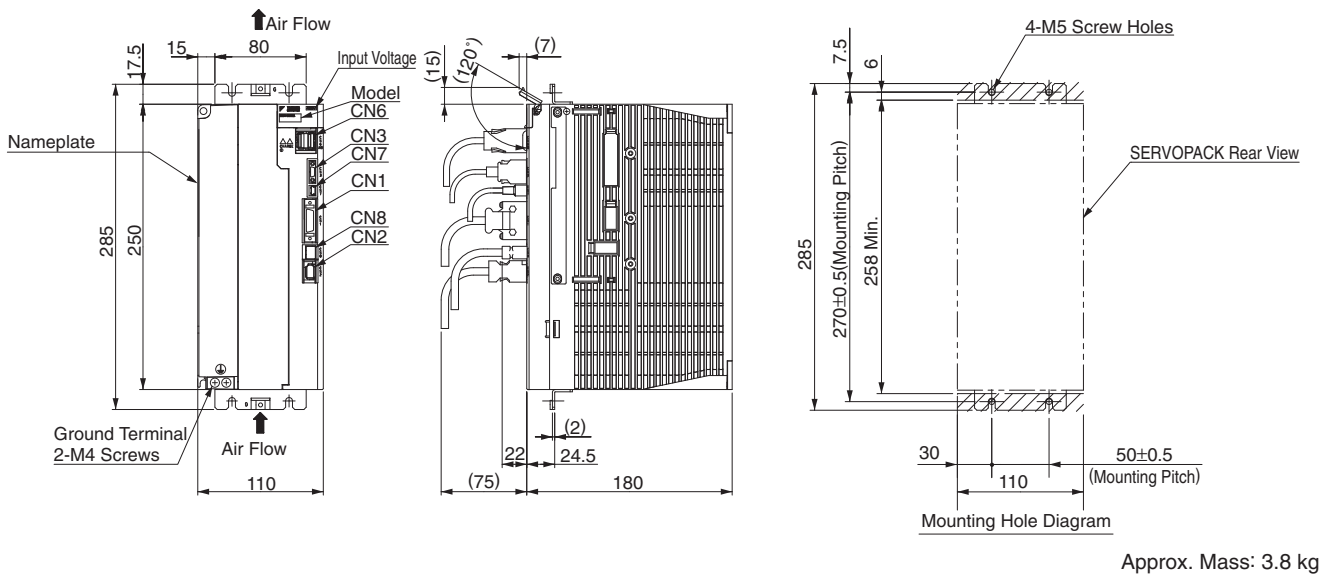

(13) Three-phase 400 VAC, Model: SGD1-170D1□A001

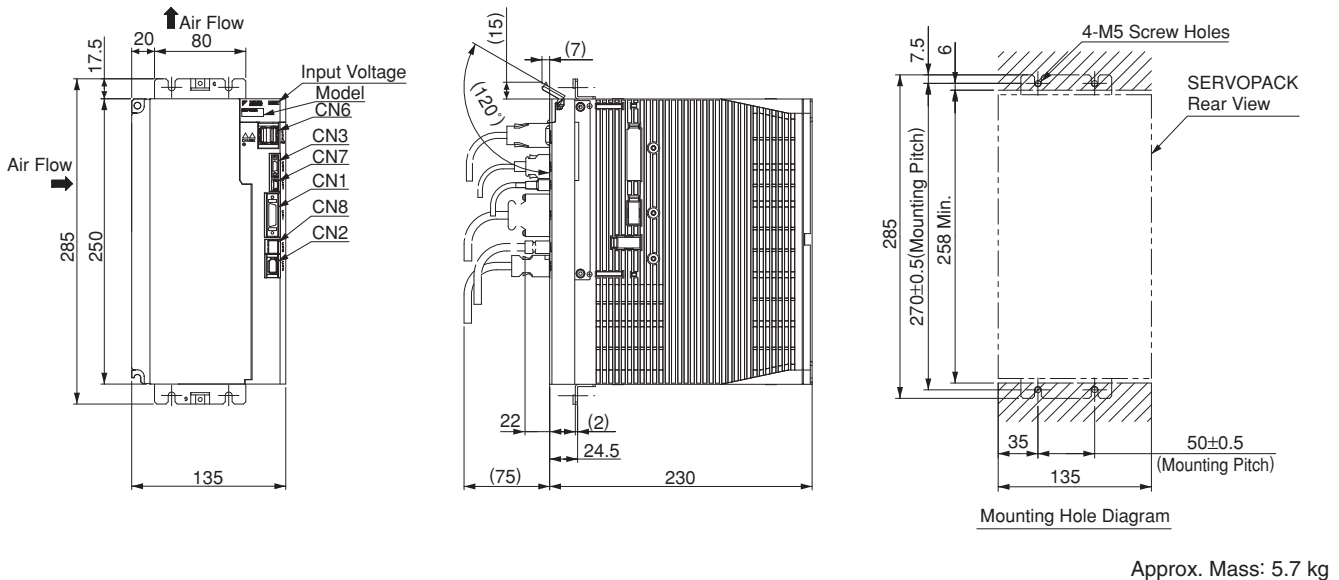

M-II Type SERVOPACKs

External Dimensions Units: mm

(14) Three-phase 400 VAC, Model: SGDV-210D1□A001 and -260D1□A001 (Duct-ventilated type)

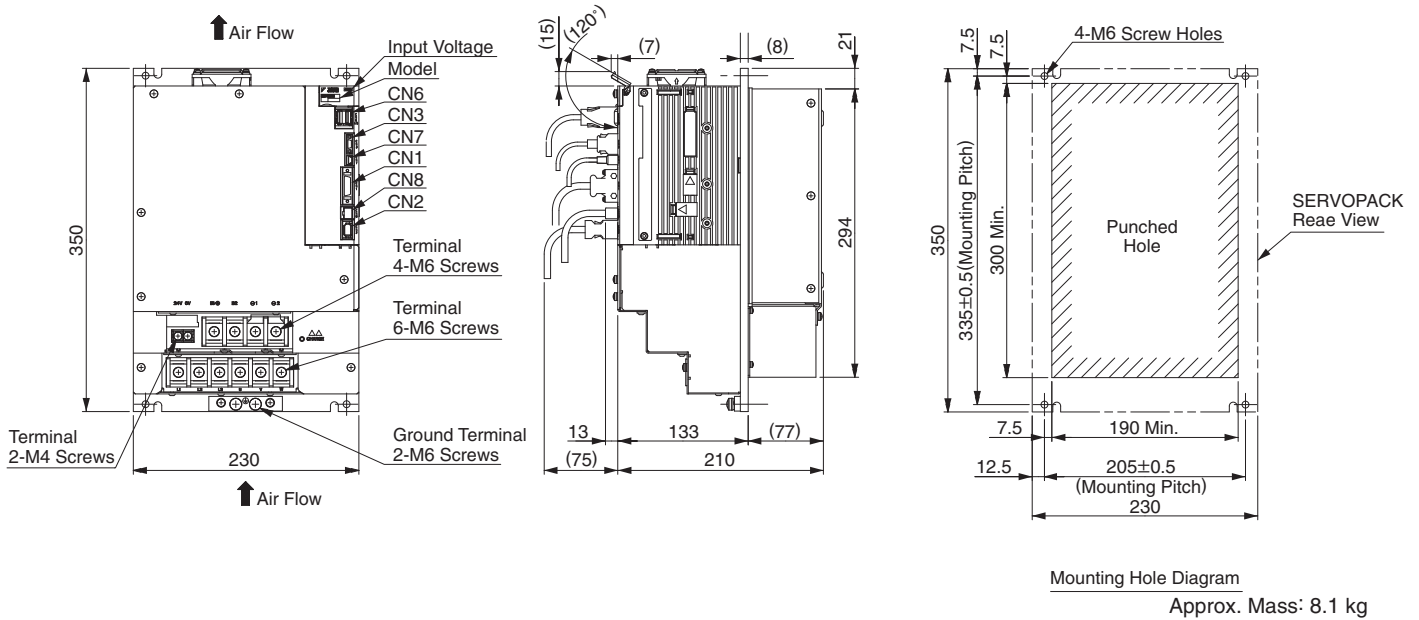

(15) Three-phase 400 VAC, Model: SGDV-280D1□A001 and -370D1□A001 (Duct-ventilated type)

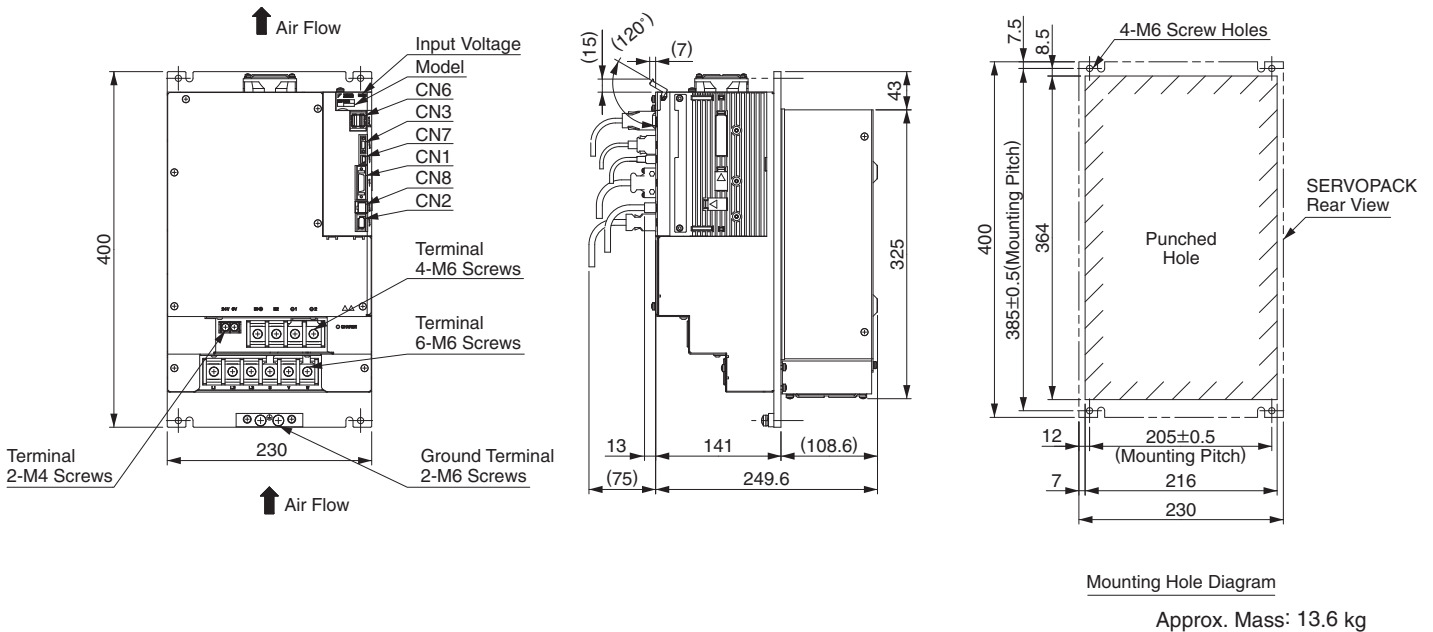

Connectors for Rack-mounted SERVOPACKs







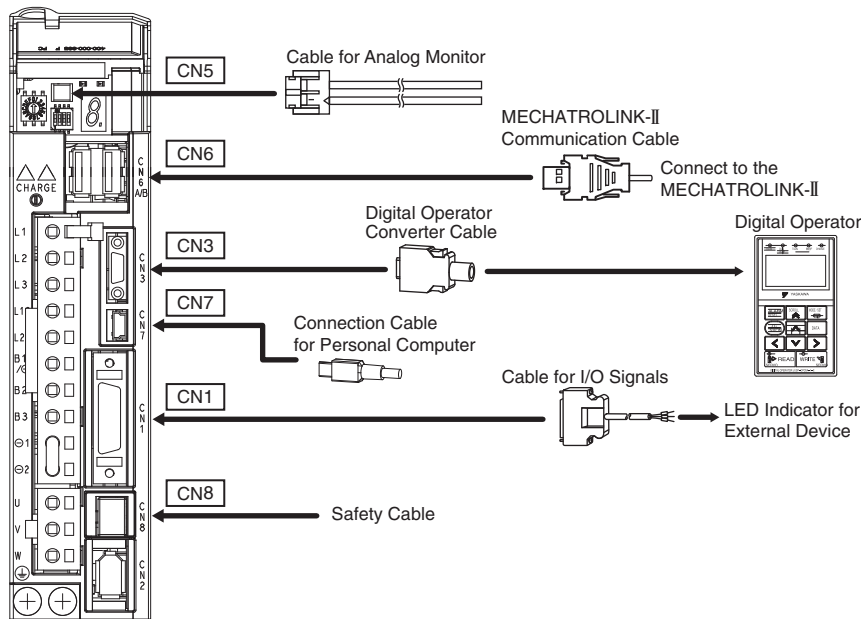

Port	Model	Pin	Manufacturer
CN1	10226-52A2PL	26	Sumitomo 3M Ltd.
CN2	53984-0671	6	Molex Japan Co., Ltd.
CN3	HDR-EC14LFDN-SLE-PLUS	14	Honda Tsushin Kogyo Co., Ltd.
CN6	1903815-1	8	Tyco Electronics AMP K.K.
CN7	MNC23-5K5H00	5	ADVANCED-CONNECTEK INC.
CN8	1981080-1	8	Tyco Electronics AMP K.K.

Note: The connectors above or their equivalents are used for SERVOPACKs.

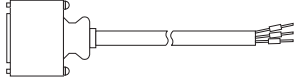
Selecting Cables

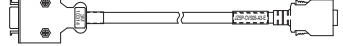
● Cables for **CN1** **CN3** **CN5** **CN6** **CN7** **CN8** (MECHATROLINK-II Communications Reference Type SERVOPACKs)

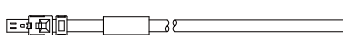

Name	Length	Order No.	Specifications	Details		
CN1 Cables for I/O Signals	Connector Kit		JZSP-CSI9-2-E	Soldered 	(1)	
	Connector Terminal Converter Unit		JZSP-TA26P-E	Terminal Block and 0.5 m Connection Cable 	(2)	
	Cable with Loose wire at One End	1 m	JZSP-CSI02-1-E		(3)	
		2 m	JZSP-CSI02-2-E			
3 m		JZSP-CSI02-3-E				
CN3	Digital Operator		JZSP-OP05A-1-E	With Connection Cable (1 m) 	(4)	
	Digital Operator Converter Cable*1	0.3 m	JZSP-CVS05-A3-E	Cable with Connectors at Both Ends 	(5)	
CN7 Connection Cables for Personal Computer	2.5 m	JZSP-CVS06-02-E	Cable with Connectors at Both Ends 	(9)		
CN6A CN6B MECHATROLINK-II Communication Cable	Cables with Connectors at Both Ends		0.5 m JEPMC-W6002-A5-E		(7)	
			1 m JEPMC-W6002-01-E			
			- JEPMC-W6002-□□-E			
Terminator		JEPMC-W6022-E		(8)		
CN5 Cables for Analog Monitor	1 m	JZSP-CA01-E	SERVOPACK End 	(6)		
CN8 Cables for Safety Functions	Cables with Connector*2		3 m	JZSP-CVH03-03-E		(10)
	Connector kit*3		Contact Tyco Electronics AMP K.K. Product name : Industrial Mini I/O D-shape Type1 Plug Connector Kit Model : 2013595-1			

*1 : A converter cable is required to use Σ -III series digital operators (model: JZSP-OP05A) for Σ -V series SERVOPACKs.

*2 : When using the safety function, connect this cable to the safety devices.

Even when not using the safety function, use SERVOPACKs with the Safe Jumper Connector (model: JZSP-CVH05-E) connected.

*3 : Use the connector kit when you make cables yourself.

Selecting Cables Units: mm

(1) Connector Kit for CN1

Use the following connector and cable to assemble the cable.
The CN1 connector kit includes one case and one connector.

Connector Kit Model	Case		Connector	
	Model	Qty	Model	Qty
JZSP-CSI9-2-E	10326-52A0-008*	1 set	10126-3000PE* (Soldered)	1

* : Manufactured by Sumitomo 3M Ltd.

• Cable Size

Item	Specifications
Cable	Use twisted-pair or twisted-pair shielded wire.
Applicable Wires	AWG24, 26, 28, 30
Cable Finished Diameter	16 dia. max.

• Dimensional Drawings of Case

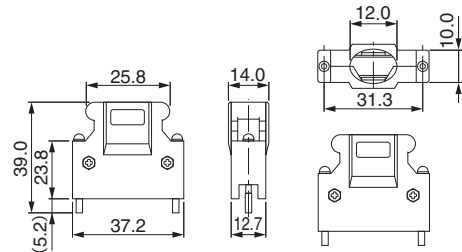

• Dimensional Drawings of Connector

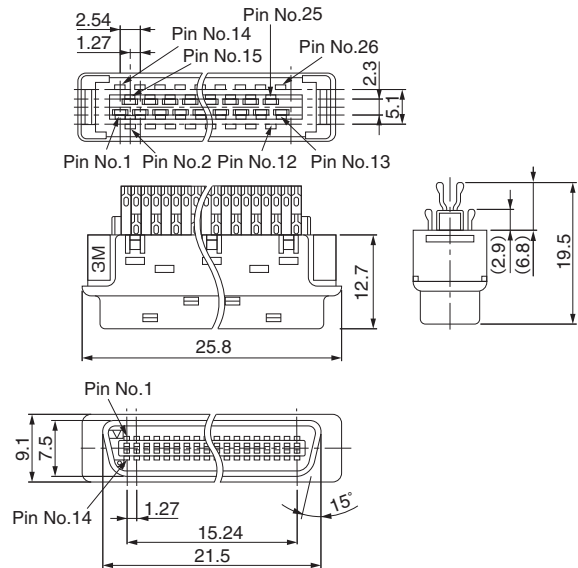

(2) Connector Terminal Converter Unit for CN1

• Configurations

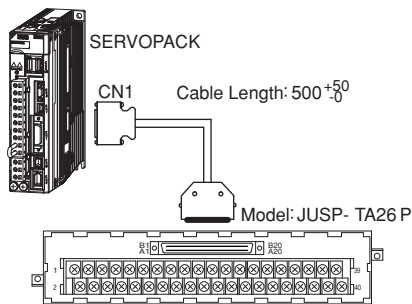

• Dimensional Drawings of Terminal Block

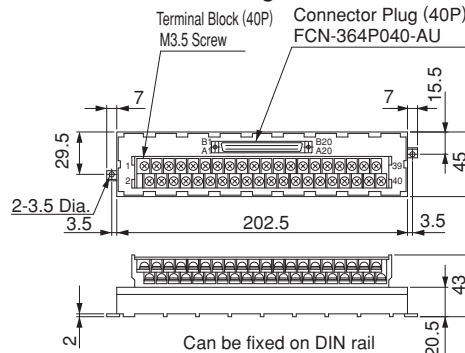

• Dimensional Drawings of Cable

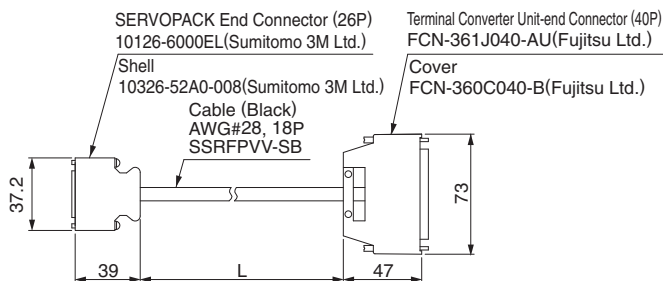

Model	Cable Length (L)	Approx. Mass
JUSP-TA26P-E	0.5 m	100 g
JUSP-TA26P-1-E	1 m	200 g
JUSP-TA26P-2-E	2 m	400 g

Selecting Cables Units: mm

(3) Cable with Loose Wires at One End for CN1
Dimensional Drawings of Cable

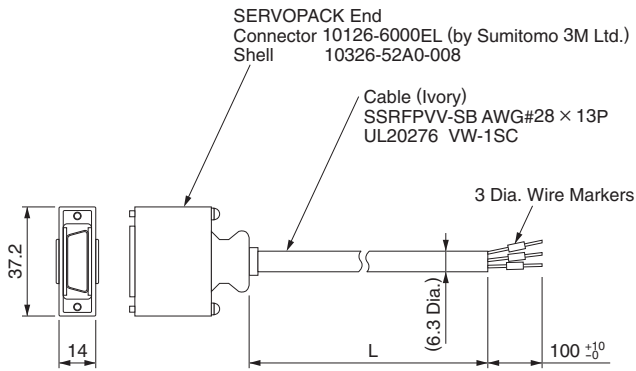

Model	Cable Length
JZSP-CSI02-1-E	1 m
JZSP-CSI02-2-E	2 m
JZSP-CSI02-3-E	3 m

● Cable with Loose Wires at One End for CN1
Connection Diagram of JZSP-CSI02-□-E Cable

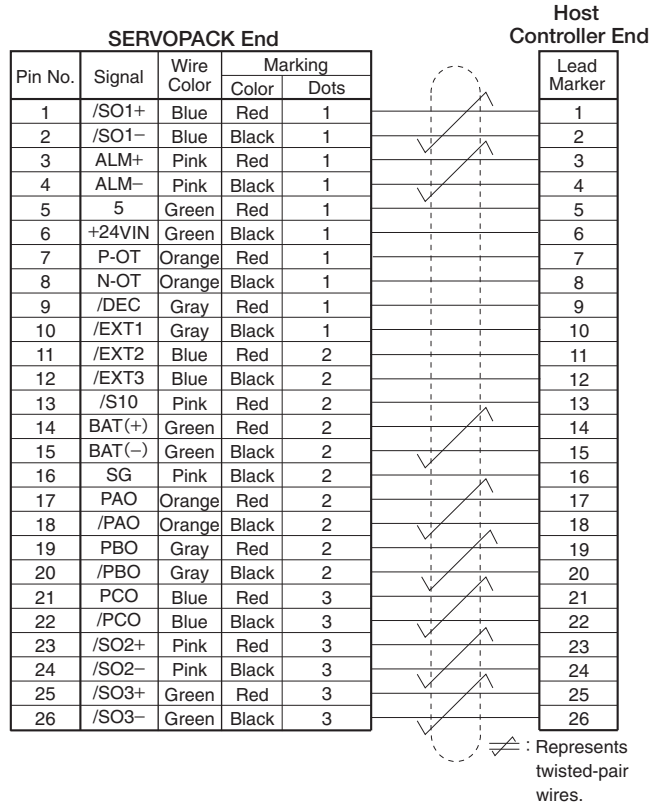

(4) Digital Operator (Model: JUSP-OP05A-1-E)

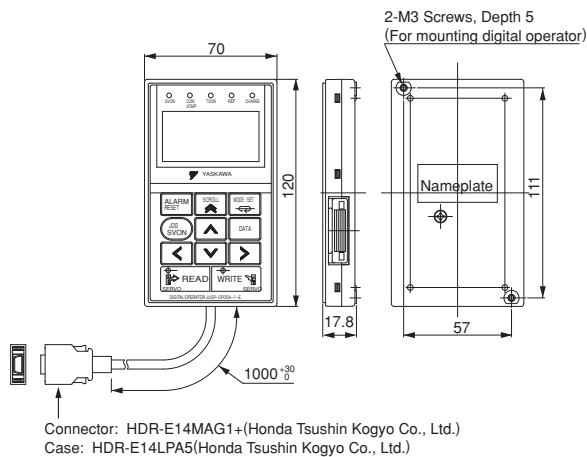

(5) Digital Operator Converter Cable for CN3
(Model: JZSP-CVS05-A3-E)

A converter cable is required to use Σ -III series digital operators (model: JUSP-OP05A) for Σ -V series SERVOPACKs.

• Dimensional Drawings

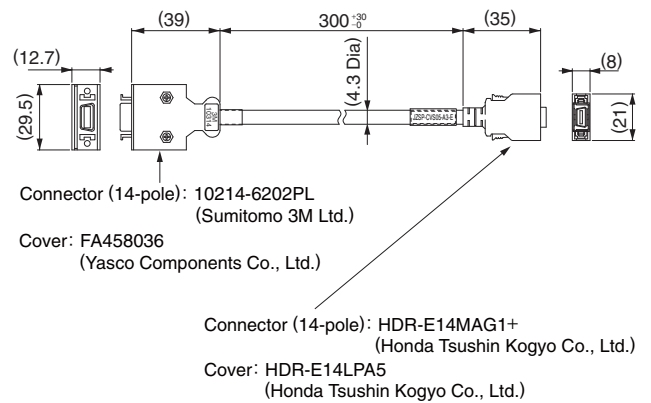

Selecting Cables Units: mm

(6) Cable for Analog Monitor for CN5 (Model: JZSP-CA01-E)

• Dimensional Drawings

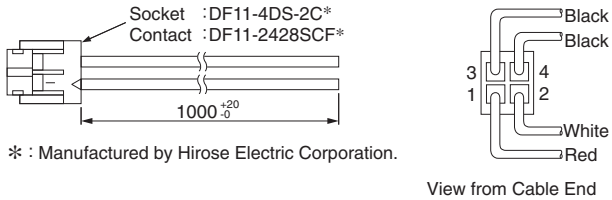

* : Manufactured by Hirose Electric Corporation.

View from Cable End

• Specifications

Pin No.	Cable Color	Signal	Standard Settings
1	Red	Analog Monitor 2	Motor speed : 1V/1000 min ⁻¹
2	White	Analog Monitor 1	Torque reference : 1V/100% rated torque
3, 4	Black (2 cables)	GND(0V)	—

Note : The specifications above are factory settings. Monitor specifications can be changed by changing parameters Pn006 and Pn007.

(7) MECHATROLINK-II Communications Cable for CN6 (Model: JEPMC-W6002-□□-E)

• Dimensional Drawings

① Cable with Connectors at Both Ends



Model	Cable Length(L)
JEPMC-W6002-A5-E	0.5 m
JEPMC-W6002-01-E	1.0 m
JEPMC-W6002-03-E	3.0 m
JEPMC-W6002-05-E	5.0 m
JEPMC-W6002-10-E	10.0 m
JEPMC-W6002-20-E	20.0 m
JEPMC-W6002-30-E	30.0 m
JEPMC-W6002-40-E	40.0 m
JEPMC-W6002-50-E	50.0 m

② Cable with Ferrite Core

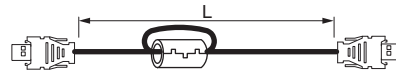

Model	Cable Length (L)
JEPMC-W6003-A5-E	0.5 m
JEPMC-W6003-01-E	1.0 m
JEPMC-W6003-03-E	3.0 m
JEPMC-W6003-05-E	5.0 m
JEPMC-W6003-10-E	10.0 m
JEPMC-W6003-20-E	20.0 m
JEPMC-W6003-30-E	30.0 m
JEPMC-W6003-40-E	40.0 m
JEPMC-W6003-50-E	50.0 m

IMPORTANT Use a MECHATROLINK-II communications cable specified by Yaskawa. When using other cables, noise resistance may be reduced, and operation cannot be guaranteed.

(8) MECHATROLINK-II Terminator for CN6 (Model : JEPMC-W6022-E)

• Dimensional Drawings

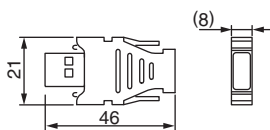

Selecting Cables Units: mm

(9) Connection Cable for Personal Computer for CN7
(Model: JZSP-CVS06-02-E)

· Dimensional Drawings

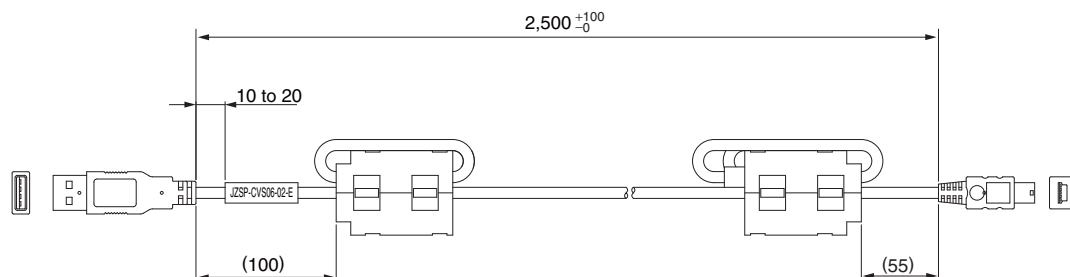

IMPORTANT Use a cable specified by Yaskawa.
When using other cables, operation cannot be guaranteed.

(10) Cable with Connector for CN8
(Model: JZSP-CVH03-03-E)

· Dimensional Drawings

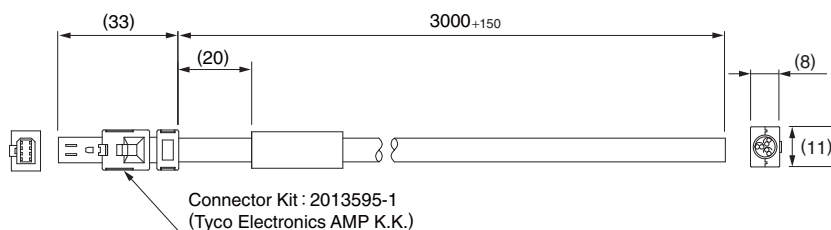

· Specifications

Pin No.	Signal	Lead Color	Marking Color
1	Not used	—	—
2	Not used	—	—
3	/HWBB1-	White	Black
4	/HWBB1+	White	Red
5	/HWBB2-	Gray	Black
6	/HWBB2+	Gray	Red
7	EDM1-	Orange	Black
8	EDM1+	Orange	Red

MECHATROLINK-III Communications Reference Type SERVOPACKs

SGDV-□□□□21
(For Rotary Servomotors)

SGDV-□□□□25
(For Linear Servomotors)



Model Designations

SGDV - R70 A 21 A □

Σ-V Series
SGDV SERVOPACK

Current

Voltage

Options

Code	Specifications
Blank	Base-mounted (standard)
001000	Rack-mounted*

*: SGD-470A, -550A, -590A, -780A, -210D, -260D, -280D, -370D SERVOPACKs are duct-ventilated.

Design Revision Order
A, B...

Interface

Code	Specifications
F	100 VAC
A	200 VAC
D	400 VAC

Code	Specifications
21	MECHATROLINK-III communications Reference Type (for rotary servomotors)
25	MECHATROLINK-III communications Reference Type (for linear servomotors)

Code	100 V		Code	200 V		Code	400 V	
	Applicable Servomotor Max. Capacity kW			Applicable Servomotor Max. Capacity kW			Applicable Servomotor Max. Capacity kW	
R70	0.05		R70	0.05		1R9	0.5	
R90	0.1		R90	0.1		3R5	1.0	
2R1	0.2		1R6	0.2		5R4	1.5	
2R8	0.4		2R8	0.4		8R4	2.0	
			3R8	0.5		120	3.0	
			5R5	0.75		170	5.0	
			7R6	1.0		210	6.0	
			120	1.5		260	7.5	
			180	2.0		280	11	
			200	3.0		370	15	
			330	5.0				
			470	6.0				
			550	7.5				
			590	11				
			780	15				

Features

- **Real-time communications**

MECHATROLINK-III communications enable high-speed control for 62 stations at a transmission speed of 100 Mbps in a transmission cycle from 125 μ s to 4 ms (user setting). Such a high transmission speed allows real-time transmission of various data required for control.

- **Cost savings**

The 62 stations can be connected to a single MECHATROLINK-III transmission line, so wiring costs and time are greatly reduced. Also, only one signal connector is required on the host controller. And, the all-digital network eliminates the need for conversion from digital to analog for speed/torque references and for a pulse generator to generate position references.

- **High-precision motion control**

The SGD V SERVOPACK when connected to the host controller in the MECHATROLINK-III network provides not only torque, position, and speed control but also synchronized phase control that requires advanced control technology. The control mode can be changed online so that the machine can move smoothly in complex motions with great efficiency.

Ratings

Single-phase 100 V

SERVOPACK Model	SGDV-□□□□	R70F	R90F	2R1F	2R8F
Applicable Servomotor Max. Capacity	kW	0.05	0.1	0.2	0.4
Continuous Output Current	Arms	0.66	0.91	2.1	2.8
Max. Output Current	Arms	2.1	2.9	6.5	9.3
Main Circuit		Single-phase 100 to 115 VAC+10% to -15% 50/60 Hz			
Control Circuit		Single-phase 100 to 115 VAC+10% to -15% 50/60 Hz			

Three-phase 200 V

SERVOPACK Model	SGDV-□□□□	R70A	R90A	1R6A	2R8A	3R8A	5R5A	7R6A	120A	180A	200A	330A	470A	550A	590A	780A
Applicable Servomotor Max. Capacity	kW	0.05	0.1	0.2	0.4	0.5	0.75	1.0	1.5	2.0	3.0	5.0	6	7.5	11	15
Continuous Output Current	Arms	0.66	0.91	1.6	2.8	3.8	5.5	7.6	11.6	18.5	19.6	32.9	46.9	54.7	58.6	78
Max. Output Current	Arms	2.1	2.9	5.8	9.3	11	16.9	17	28	42	56	84	110	130	140	170
Main Circuit		Three-phase 200 to 230 VAC+10% to -15% 50/60 Hz														
Control Circuit		Single-phase 200 to 230 VAC+10% to -15% 50/60 Hz														

Three-phase 400 V

SERVOPACK Model	SGDV-□□□□	1R9D	3R5D	5R4D	8R4D	120D	170D	210D	260D	280D	370D
Applicable Servomotor Max. Capacity	kW	0.5	1.0	1.5	2.0	3.0	5.0	6	7.5	11	15
Continuous Output Current	Arms	1.9	3.5	5.4	8.4	11.9	16.5	20.8	25.4	28.1	37.2
Max. Output Current	Arms	5.5	8.5	14	20	28	42	55	65	70	85
Main Circuit		Three-phase 380 to 480 VAC+10% to -15% 50/60 Hz									
Control Circuit		24 VDC \pm 15%									

● SERVOPACK Overload Characteristics

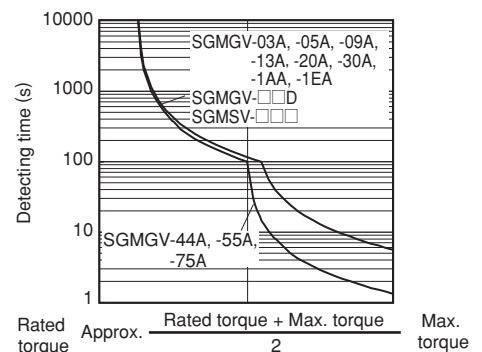
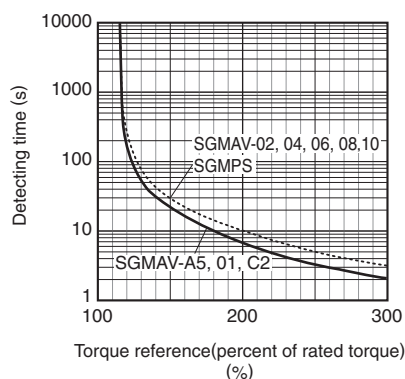
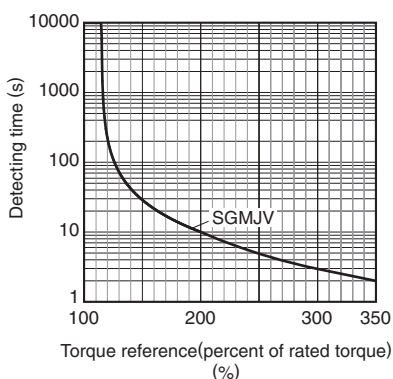

Note: Overload characteristics shown above do not guarantee continuous duty of 100% or more output. Use a servomotor with effective torque within the continuous duty zone of *Torque-Motor Speed Characteristics*.

Specifications

Items		Specifications	
Control Method		IGBT PWM control, sine-wave driven	
Feedback	Rotary Servomotors	Serial encoder: 13-bit (incremental encoder) : 17-bit (incremental/absolute encoder) : 20-bit (incremental/absolute encoder)	
	With Linear Servomotors	Serial converter unit or linear scale	
Operating Conditions	Surrounding Air/Storage Temperature	Surrounding air temperature: 0 to +55°C, Storage temperature: -20 to +85°C	
	Ambient/Storage Humidity	90%RH or less (no condensation)	
	Vibration/Shock Resistance	Vibration resistance: 4.9 m/s ² , Shock resistance: 19.6 m/s ²	
	Protection Class/Pollution Degree	Protection class: IP10, pollution degree: 2 Do not use SERVOPACKs in the following locations: · Locations subject to corrosive or flammable gasses · Locations subject to exposure to water, oil, or chemicals · Locations subject to dust, including iron dust, and salts	
	Others	Do not use SERVOPACKs in the following locations: · Locations subject to static electricity noise, strong electromagnetic/magnetic fields, radioactivity	
Altitude		1000 m or less	
Applicable Standards (Pending)		UL508C EN50178, EN55011/A2 group1 classA, EN61000-6-2, EN61800-3, EN61800-5-1, EN954-1, IEC61508-1 to 4	
Configuration		Standard: Base-mounted Optional: Rack-mounted, Duct-ventilated	
Performance	Speed Control Range		
	Speed Regulation*1	Load Fluctuation	0% to 100% load: ±0.01% max. (at rated speed)
		Voltage Fluctuation	Rated voltage: ±10% : 0% (at rated speed)
		Temperature Fluctuation	25±25°C : ±0.1% max. (at rated speed)
	Torque Control Tolerance (Repeatability)		±1%
Soft Start Time Setting		0 to 10 s (can be set individually for acceleration and deceleration.)	
Communications	RS-422A Communications	Interface	Digital operator (JUSP-OP05A-1-E), personal computer (can be connected with SigmaWin+)
		1:N communications	RS-422A port: N= 15 max. available
		Axis address setting	Set by parameters
	USB Communications	Interface	Personal computer (can be connected with SigmaWin+.)
		Communications Standard	Compliant with USB1.1 standard (12 Mbps)
Display		CHARGE indicator	
Analog Monitor		Number of points: 2 Output voltage: ±10 VDC (linearity effective range ±8 V) Resolution: 16 bit Accuracy: ±20 mV (Typ) Max. output current: ±10 mA Settling time (±1%): 1.2 ms (Typ)	
Dynamic Brake (DB)		Activated when a servo alarm or overtravelling (OT) occurs, or when the power supply for the main circuit or servomotor is OFF.	
Protective Functions		Overcurrent, Overvoltage, low voltage, overload, regeneration error, etc.	
Utility Functions		Gain adjustment, alarm history, JOG operation, origin search, etc.	
Regenerative Processing		100 VAC model: External regenerative resistor (optional) 200 VAC SGD V-R70A, -R90A, -1R6A, -2R8A: External regenerative resistor (optional) 200 VAC SGD V-470A, -550A, -590A, -780A: External regenerative resistor unit (optional) 200 VAC models other than shown above: Built-in regenerative resistor 400 VAC SGD V-210D, -260D, -280D, -370D: External regenerative resistor unit (optional) 400 VAC models other than shown above: Built-in regenerative resistor	
Overtravelling (OT) Prevention		Dynamic brake stop at P-OT or N-OT, deceleration to a stop, or free run to a stop	
Safety Functions	Input	/HWBB1, /HWBB2: Baseblock signal for power module	
	Output	EDM1: Status monitor (fixed output) of built-in safety circuit	
	Applicable Standards (Pending)*2		EN954 category 3, IEC61508 SIL2
Option Module		Fully-closed option module	

*1: Speed regulation is defined as follows:

$$\text{Speed regulation} = \frac{\text{No-load motor speed} - \text{Total load motor speed}}{\text{Rated motor speed}} \times 100\%$$

The motor speed may change due to voltage fluctuation or temperature fluctuation.

The ratio of speed changes to the rated speed represent speed regulation due to voltage and temperature fluctuations.

*2: Perform risk assessment for the system and confirm that the safety requirements for the standards are fulfilled before using the HWBB function.

Specifications

● Rotary Servomotors

Items		Specifications		
I/O Signal	Encoder Output Pulses	Phase A, phase B, phase C: line driver output The number of dividing pulse: Any setting ratio is available.		
		Sequence Input	Fixed Input	SEN signal
	Input Signals which can be allocated		Number of Channels	7 channels
		Sequence Output	Output Signals which can be allocated	Function
	Fixed Output			Servo alarm (ALM)
		Function	Signal allocations and positive/negative logics can be modified. Positioning completion (/COIN), speed coincidence detection (/V-CMP), servomotor rotation detection (/TGON), servo ready (/S-RDY), torque limit detection (/CLT), speed limit detection (/VLT), brake (/BK), warning (/WARN), NEAR (/NEAR)	
Panel Operator	Display		7-segment 1-digit LED (red), LED for MECHATROLINK Communications (green)×3	
	Switch	Rotary switch: 16 positions×2, DIP switch: 4 poles		
MECHATROLINK Communications	Communications Protocol	MECHATROLINK-III		
	Transmission Speed	100 Mbps		
	Transmission Cycle	125 μs, 250 μs, 500 μs, 750 μs, 1 ms to 4 ms (increments of 0.5 ms)		
	Number of Words for Link Transmission	Can be switched between 16-bytes/station, 32-bytes/station and 48-bytes/station.		
	Station Address	03H to EFH (max. number of slaves: 62)		
Command Method	Performance	Position control, speed control, and torque control through MECHATROLINK communications		
	Command Input	MECHATROLINK commands (for sequence, motion, data setting/reference, monitor, adjustment, and other commands.)		

● Linear Servomotors

Items		Specifications		
I/O Signal	Encoder Output Pulses	Phase A, phase B, phase C: line driver output The number of dividing pulse: Any setting ratio is available.		
		Sequence Input	Fixed Input	SEN signal
	Input Signals which can be allocated		Number of Channels	7 channels
		Sequence Output	Output Signals which can be allocated	Function
	Fixed Output			Servo alarm (ALM)
		Function	Signal allocations and positive/negative logics can be modified. Positioning completion (/COIN), speed coincidence detection (/V-CMP), servomotor movement detection (/TGON), servo ready (/S-RDY), force limit detection (/CLT), speed limit detection (/VLT), brake (/BK), warning (/WARN), NEAR (/NEAR)	
Panel Operator	Display		7-segment 1-digit LED (red), LED for MECHATROLINK Communications (green)×3	
	Switch	Rotary switch: 16 positions×2, DIP switch: 4 poles		
MECHATROLINK Communications	Communications Protocol	MECHATROLINK-III		
	Transmission Speed	100 Mbps		
	Transmission Cycle	125 μs, 250 μs, 500 μs, 750 μs, 1 ms to 4 ms (increments of 0.5 ms)		
	Number of Words for Link Transmission	Can be switched between 16-bytes/station, 32-bytes/station and 48-bytes/station.		
	Station Address	03H to EFH (max. number of slaves: 62)		
Command Method	Performance	Position control, speed control, and force control through MECHATROLINK communications		
	Command Input	MECHATROLINK commands (for sequence, motion, data setting/reference, monitor, adjustment, and other commands.)		

Power Supply Capacities and Power Losses

The following table shows SERVOPACK's power supply capacities and power losses at the rated output.

Main Circuit Power Supply	Applicable Servomotor Max. Capacity kW	SERVOPACK Model SGD V-	Power Supply Capacity kVA	Output Current Arms	Main Circuit Power Loss W	Regenerative Resistor Power Loss	Control Circuit Power Loss W	Total Power Loss W
						W		
Signal-phase 100 V	0.05	R70F	0.2	0.66	5.4	—	17	22.4
	0.1	R90F	0.3	0.91	7.8			24.8
	0.2	2R1F	0.7	2.1	14.4			31.4
	0.4	2R8F	1.4	2.8	25.6			42.6
Single-phase 200 V	0.05	R70A	0.2	0.66	5.2	—	17	22.2
	0.1	R90A	0.3	0.91	7.4			24.4
	0.2	1R6A	0.7	1.6	13.7			30.7
	0.4	2R8A	1.2	2.8	24.9			41.9
	0.75	5R5A	1.9	5.5	52.7	8	77.7	
	1.5	120A	4	11.6	68.2	10	22	100.2
Three-phase 200 V	0.05	R70A	0.2	0.66	5.1	—	17	22.1
	0.1	R90A	0.3	0.91	7.3			24.3
	0.2	1R6A	0.6	1.6	13.5			30.5
	0.4	2R8A	1	2.8	24.0			41.0
	0.5	3R8A	1.4	3.8	20.1			45.1
	0.75	5R5A	1.6	5.5	43.8	8	68.8	
	1.0	7R6A	2.3	7.6	53.6		78.6	
	1.5	120A	3.2	11.6	65.8	10	22	97.8
	2.0	180A	4	18.5	111.9	16		149.9
	3.0	200A	5.9	19.6	113.8	36	27	161.4
	5.0	330A	7.5	32.9	263.7			312.4
	6.0	470A	10.7	46.9	279.4	(180)*1	33	390.8
	7.5	550A	14.6	54.7	357.8	(350)*2		48
	11	590A	21.7	58.6	431.7		647.0	
	15	780A	29.6	78	599.0			
Three-phase 400 V	0.5	1R9D	1.1	1.9	24.6	14	21	59.6
	1.0	3R5D	2.3	3.5	46.1			81.1
	1.5	5R4D	3.5	5.4	71.3			106.3
	2.0	8R4D	4.5	8.4	77.9	28	25	130.9
	3.0	120D	7.1	11.9	108.7			161.7
	5.0	170D	11.7	16.5	161.1	36	24	221.1
	6.0	210D	12.4	20.8	172.7			(180)*3
	7.5	260D	14.4	25.7	218.6	245.6		
	11	280D	21.9	28.1	294.6	(350)*4	30	
	15	370D	30.6	37.2	403.8			433.8

*1: For the optional JUSP-RA04-E regenerative resistor unit.

*2: For the optional JUSP-RA05-E regenerative resistor unit.

*3: For the optional JUSP-RA18-E regenerative resistor unit.

*4: For the optional JUSP-RA19-E regenerative resistor unit.

Notes: 1 SGD V-R70F, -R90F, -2R1F, -2R8F, -R70A, -R90A, -1R6A, and -2R8A SERVOPACKs do not have built-in regenerative resistors.

If the regenerative energy exceeds the specified value, connect an external regenerative resistor (optional).

2 SGD V-470A, -550A, -590A, -780A, -210D, -260D, -280D, -370D SERVOPACKs do not have built-in regenerative resistors.

Be sure to connect a regenerative resistor unit (optional) or an external regenerative resistor (optional). For selection details, refer to page 360.

3 Regenerative resistor power losses are allowable losses. Take the following action if this value is exceeded.

· Remove the lead or short bar that is short-circuiting the SERVOPACK main circuit terminal B2 and B3.

(SGDV-3R8A, -5R5A, -7R6A, -120A, -180A, -200A, -330A, or 400-V class SERVOPACKs.)

· Install an external regenerative resistor (optional). For selection details, refer to page 360.

External Dimensions Units: mm

● **Base-mounted SERVOPACKs**

(1) Single-phase 100 VAC, Model: SGDV-R70F2□A, -R90F2□A, and -2R1F2□A

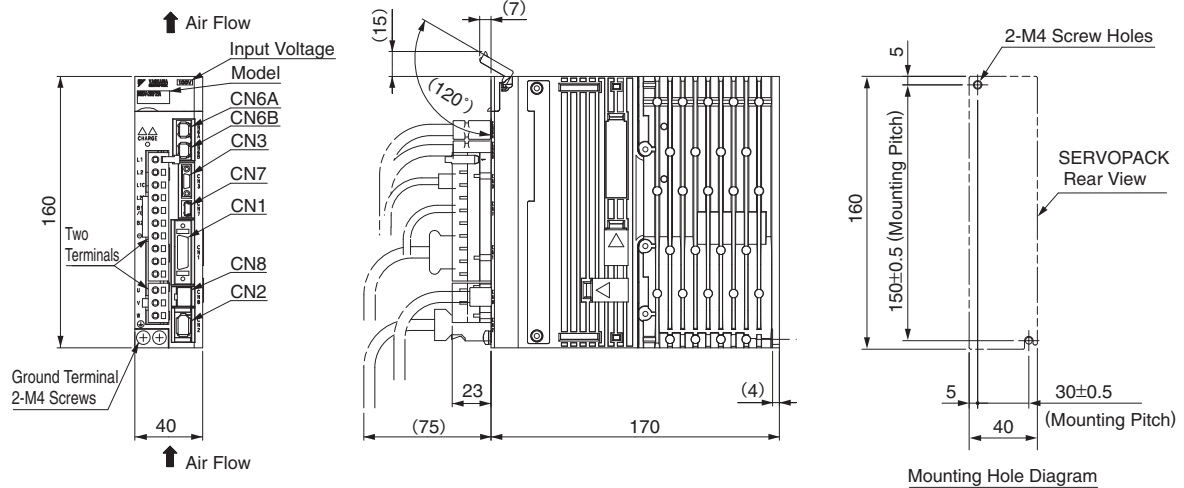

Mounting Hole Diagram

Approx. Mass: 1.0 kg

(2) Single-phase 100 VAC, Model: SGDV-2R8F2□A

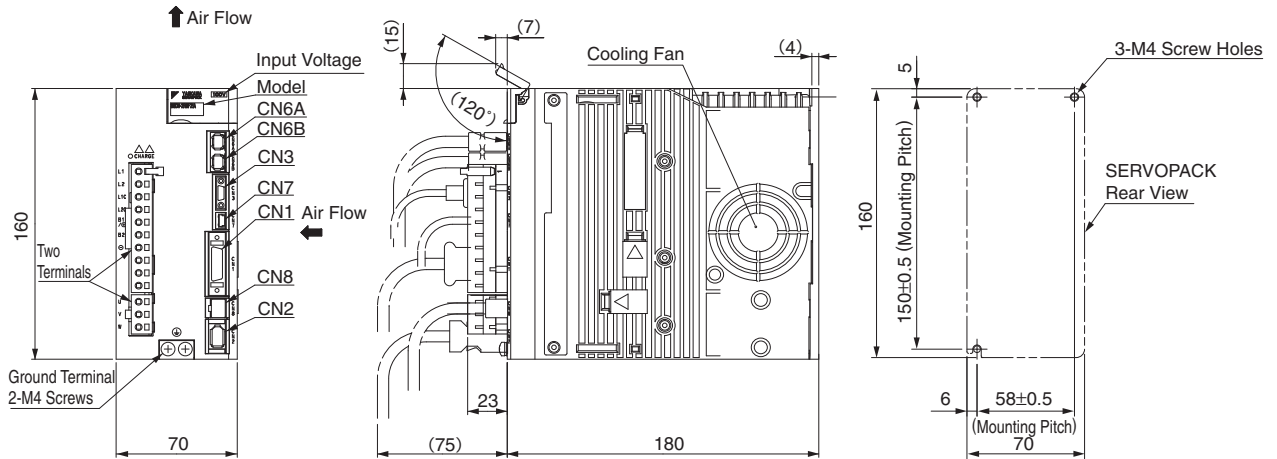

Mounting Hole Diagram

Approx. Mass: 1.5 kg

(3) Three-phase 200 VAC, Model: SGDV-R70A2□A, -R90A2□A, and -1R6A2□A

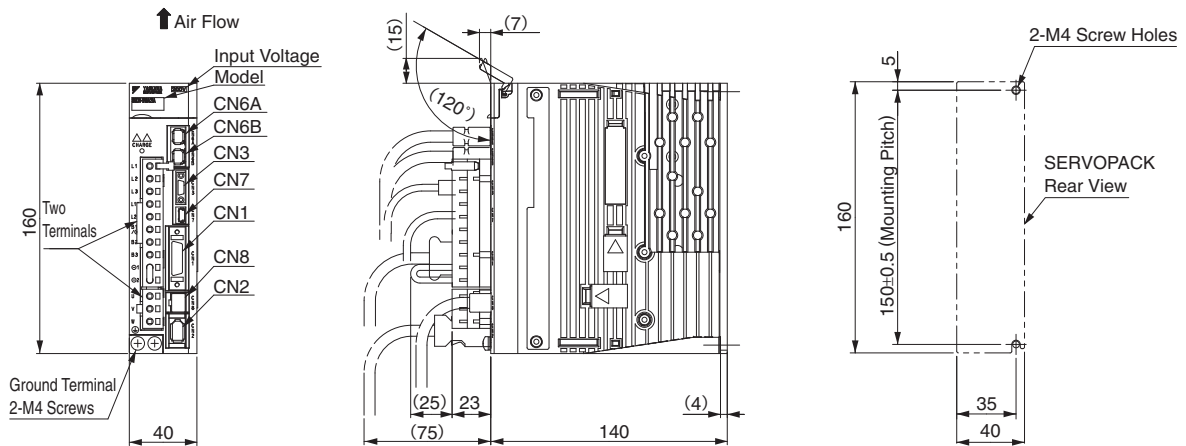

Mounting Hole Diagram

Approx. Mass: 0.9 kg

External Dimensions Units: mm

(4) Three-phase 200 VAC, Model: SGDV-2R8A2□A

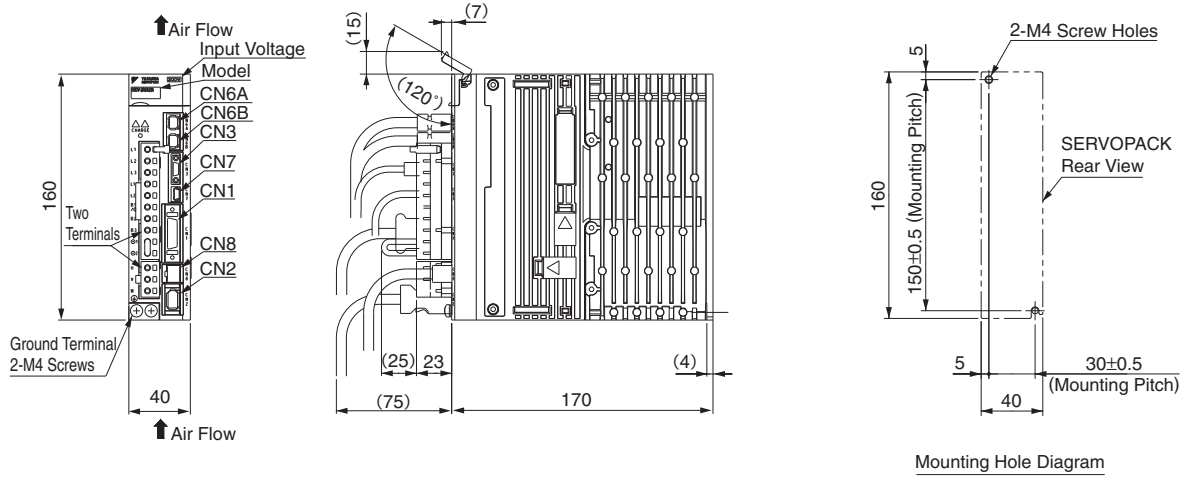

Approx. Mass: 1.0 kg

(5) Three-phase 200 VAC, Model: SGDV-3R8A2□A, -5R5A2□A, and -7R6A2□A

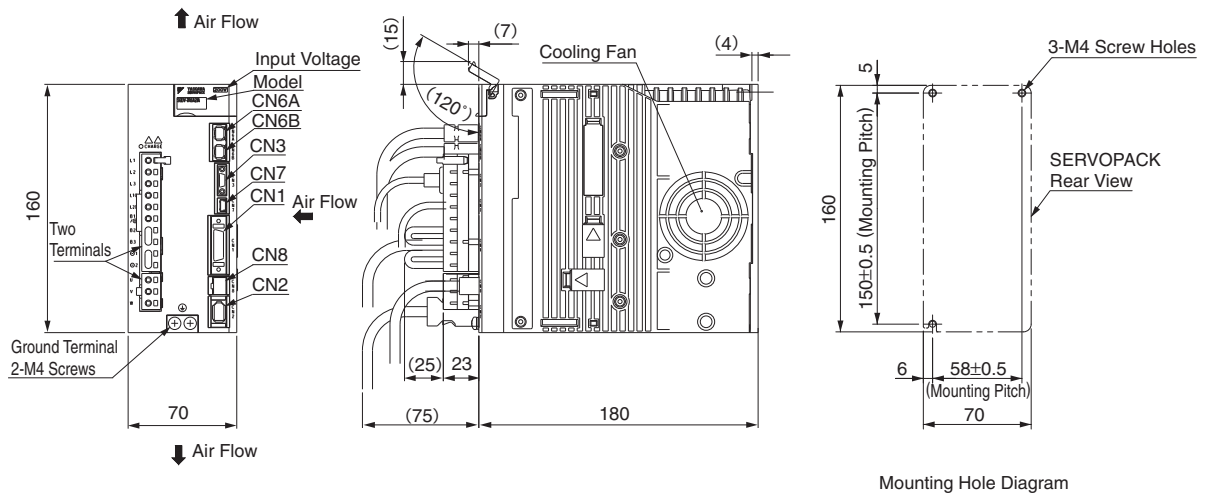

Approx. Mass: 1.5 kg

(6) Three-phase 200 VAC, Model: SGDV-120A2□A

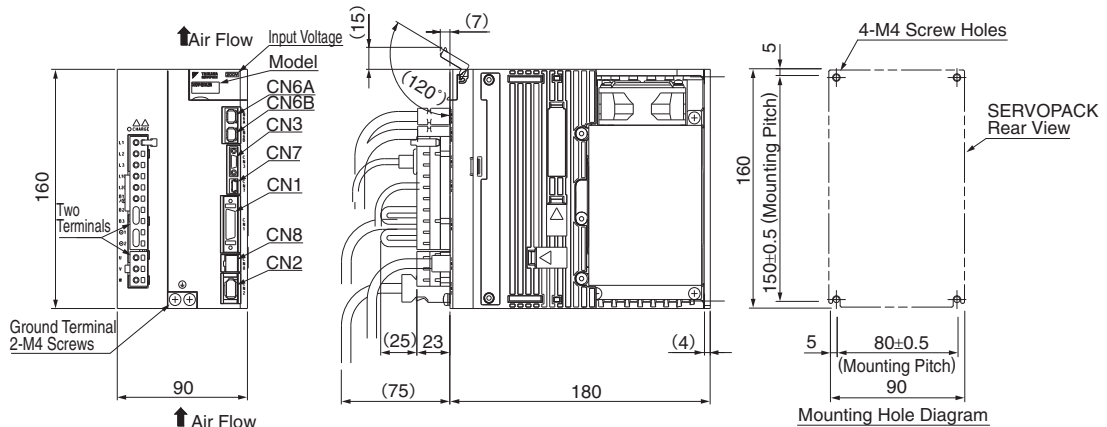

Approx. Mass: 2.4 kg

External Dimensions Units: mm

(7) Three-phase 200 VAC, Model: SGDV-180A2□A and -200A2□A

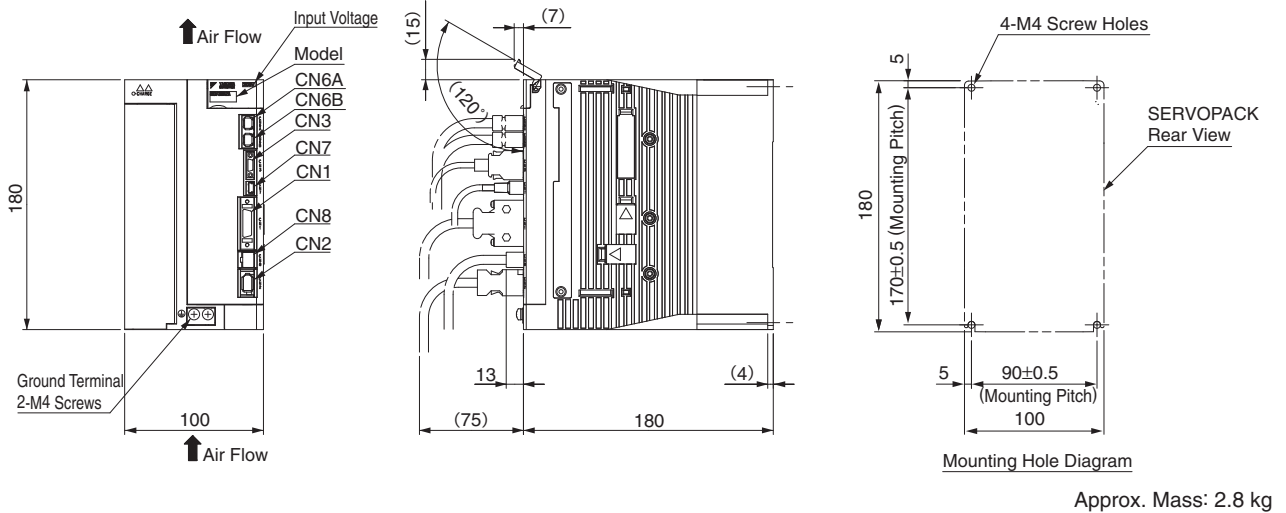

(8) Three-phase 200 VAC, Model: SGDV-330A2□A

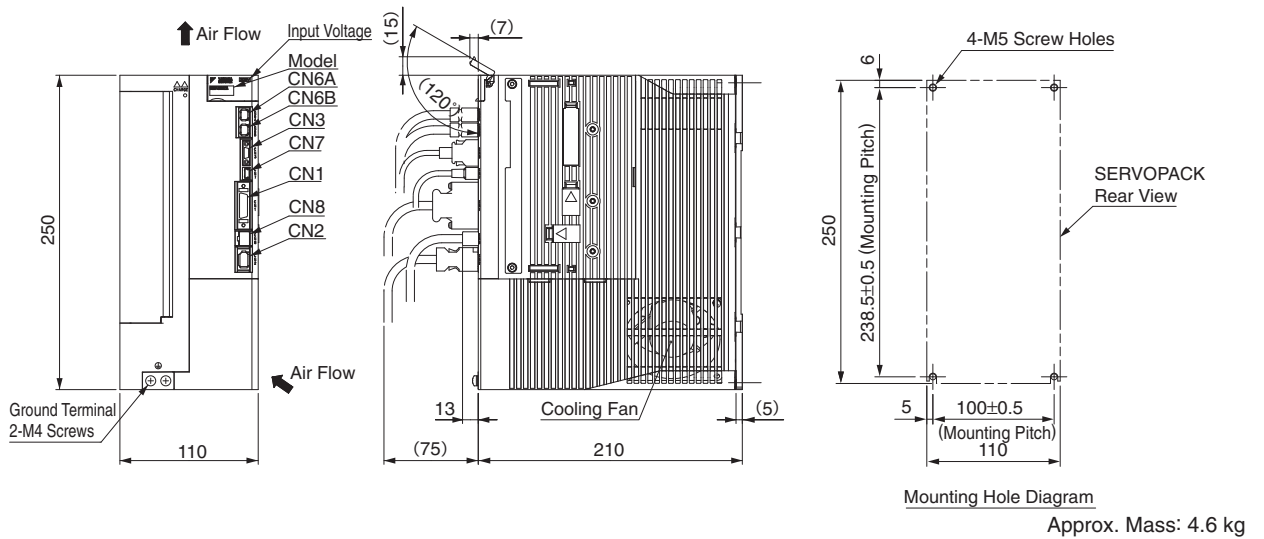

(9) Three-phase 400 VAC, Model: SGDV-1R9D2□A, -3R5D2□A, and -5R4D2□A

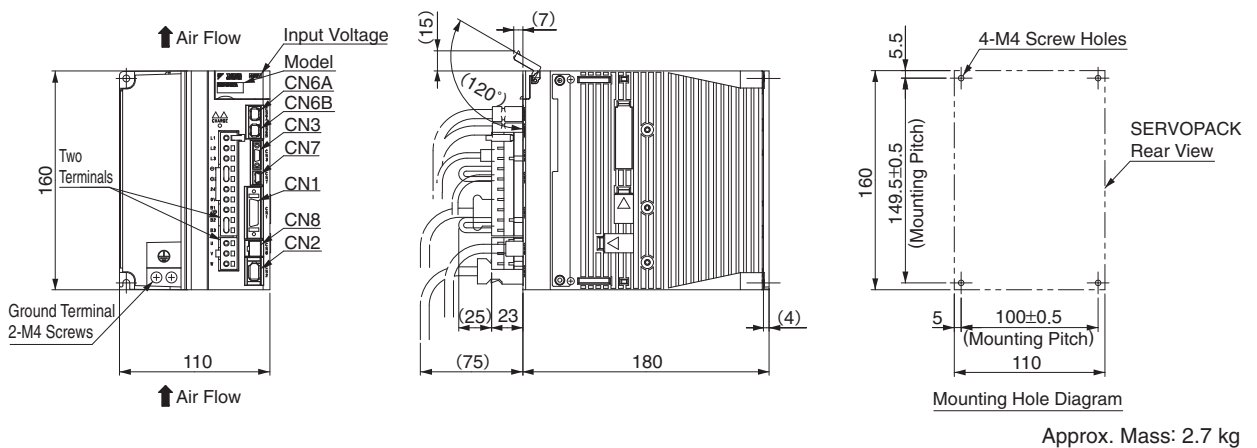

External Dimensions Units: mm

(10) Three-phase 400 VAC, Model: SGD V-8R4D2□A and -120D2□A

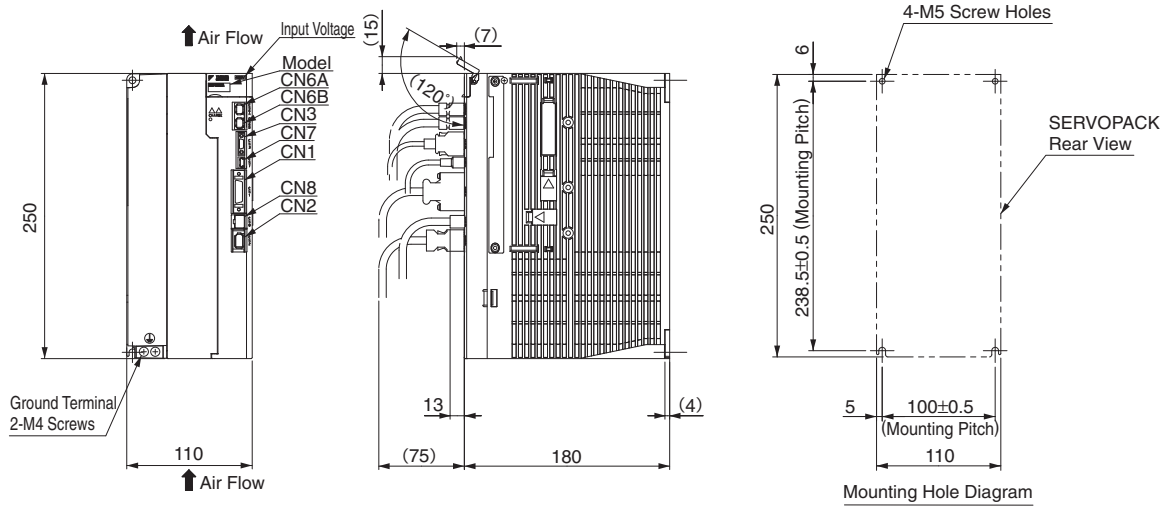

Approx. Mass: 3.7 kg

(11) Three-phase 400 VAC, Model: SGD V-170D2□A

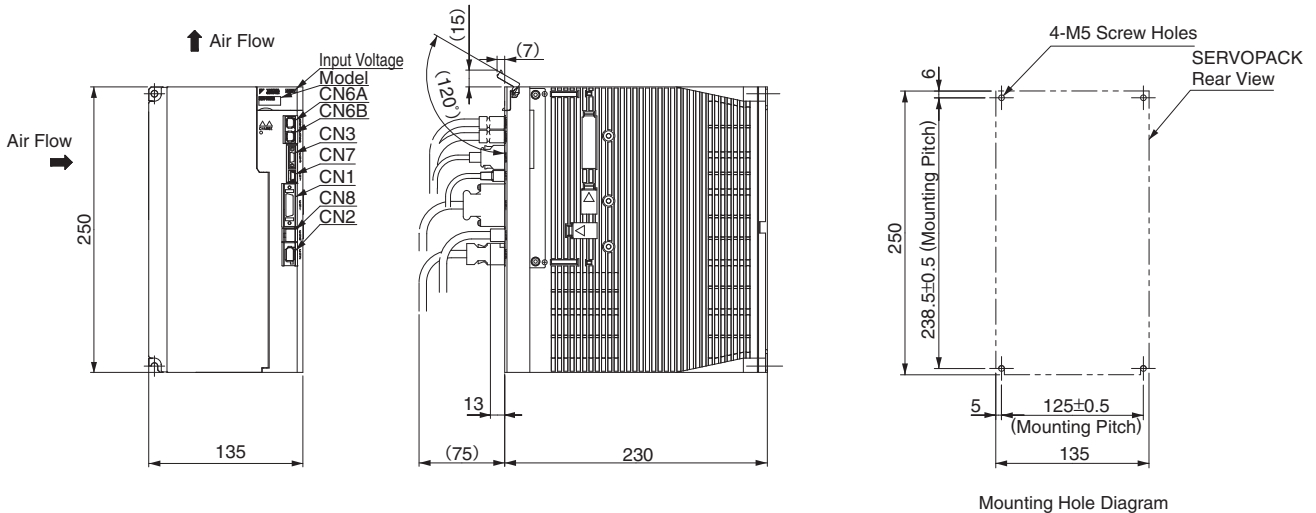

Approx. Mass: 5.6 kg

Connectors for Base-mounted SERVOPACKs

Port	Model	Pin	Manufacturer
CN1	10226-52A2PL	26	Sumitomo 3M Ltd.
CN2	53984-0671	6	Molex Japan Co., Ltd.
CN3	HDR-EC14LFD TN-SLE-PLUS	14	Honda Tsushin Kogyo Co., Ltd.
CN6A	1981386-1	8	Tyco Electronics AMP K.K.
CN6B	1981386-1	8	Tyco Electronics AMP K.K.
CN7	MNC23-5K5H00	5	ADVANCED-CONNECTEK INC.
CN8	1981080-1	8	Tyco Electronics AMP K.K.

Note: The connectors above or their equivalents are used for SERVOPACKs.

External Dimensions Units: mm

● **Rack-mounted SERVOPACKs**

(1) Single-phase 100 VAC, Model: SGDV-R70F2□A001, -R90F2□A001, and -2R1F2□A001

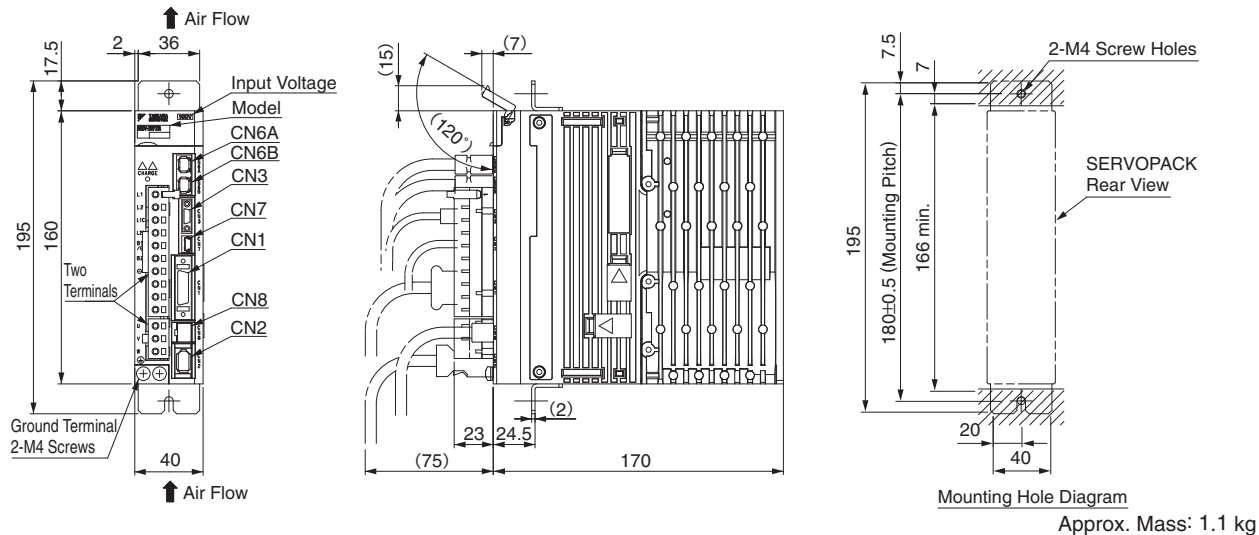

(2) Single-phase 100 VAC, Model: SGDV-2R8F2□A001

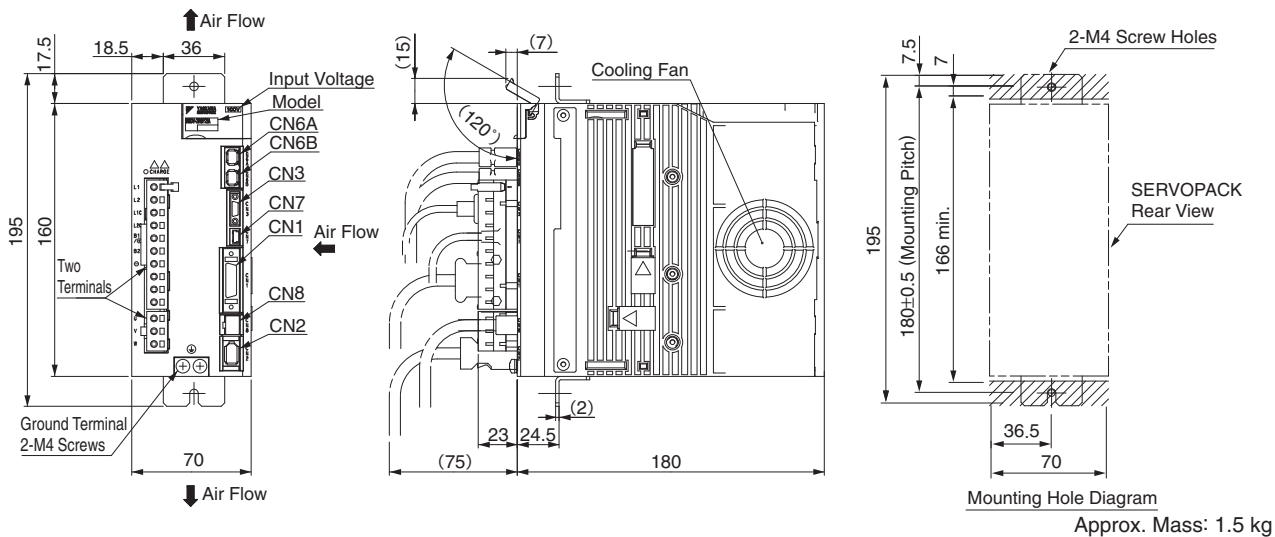

(3) Three-phase 200 VAC, Model: SGDV-R70A2□A001, -R90A2□A001, and -1R6A2□A001

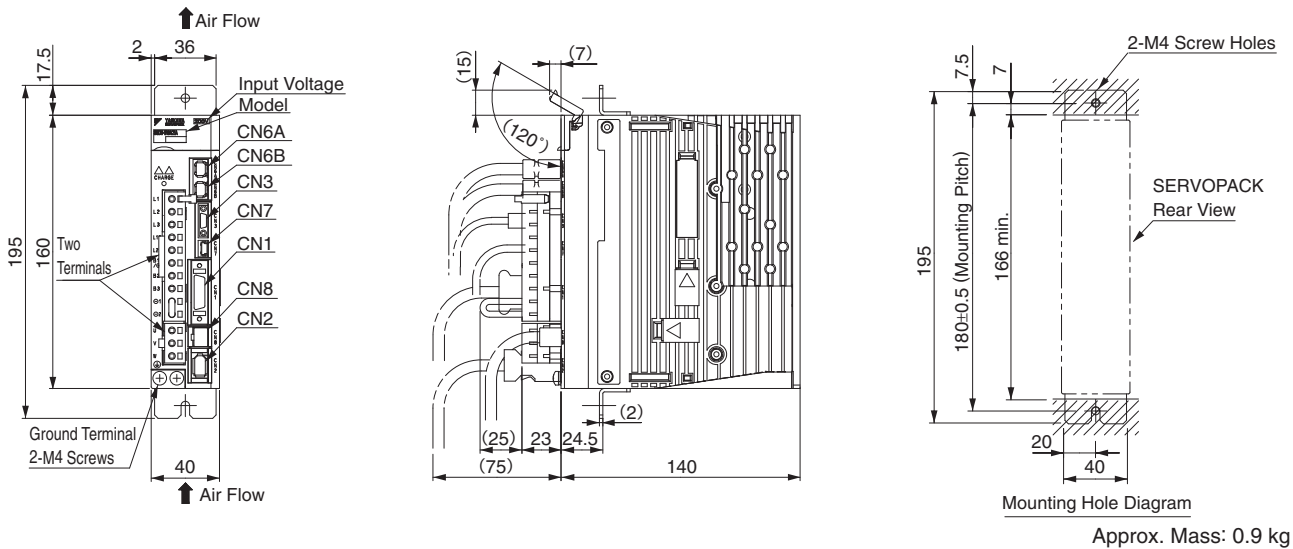

External Dimensions Units: mm

(4) Three-phase 200 VAC, Model: SGDV-2R8A2□A001

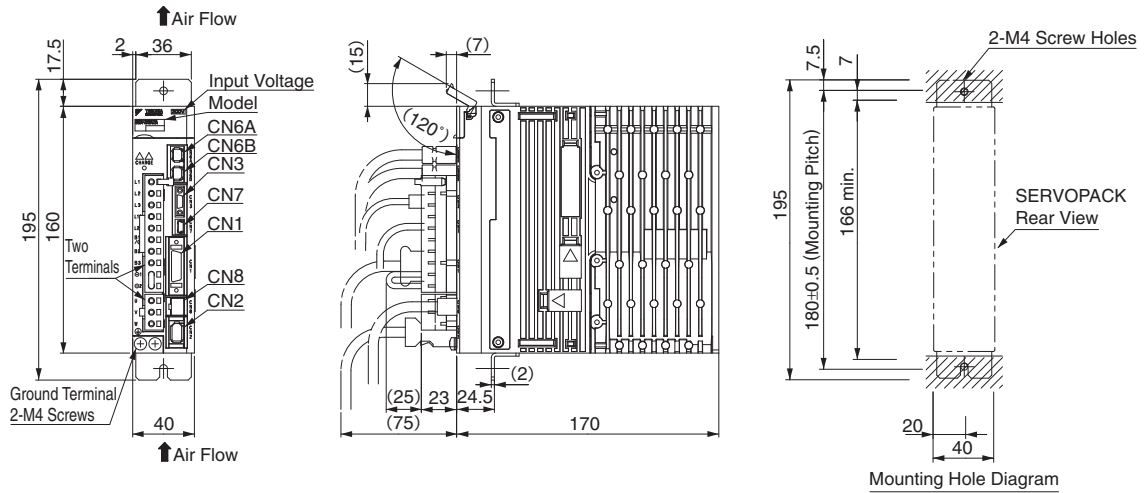

Approx. Mass: 1.0 kg

(5) Three-phase 200 VAC, Model: SGDV-3R8A2□A001, -5R5A2□A001, and -7R6A2□A001

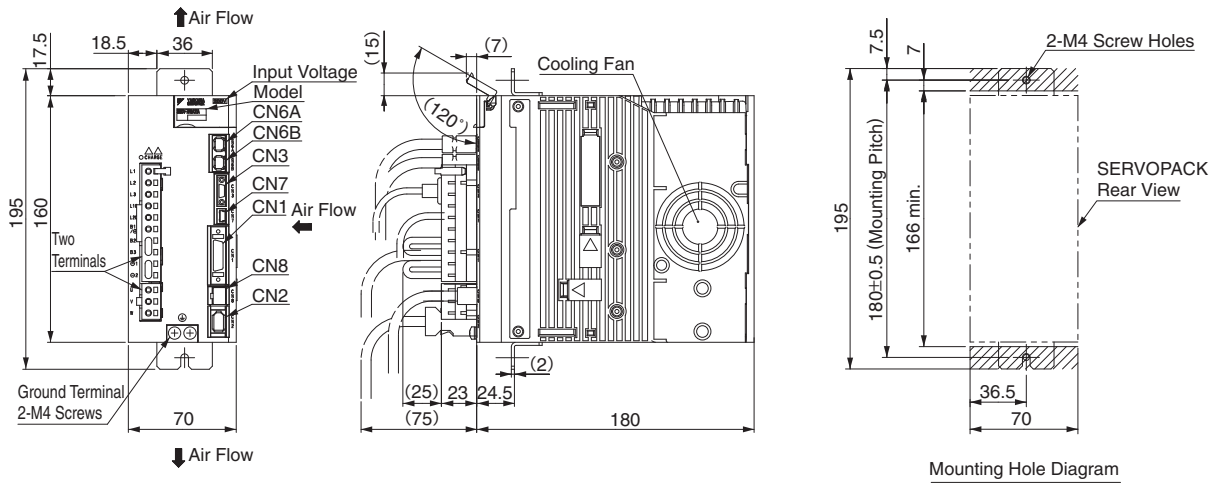

Approx. Mass: 1.5 kg

(6) Three-phase 200 VAC, Model: SGDV-120A2□A001

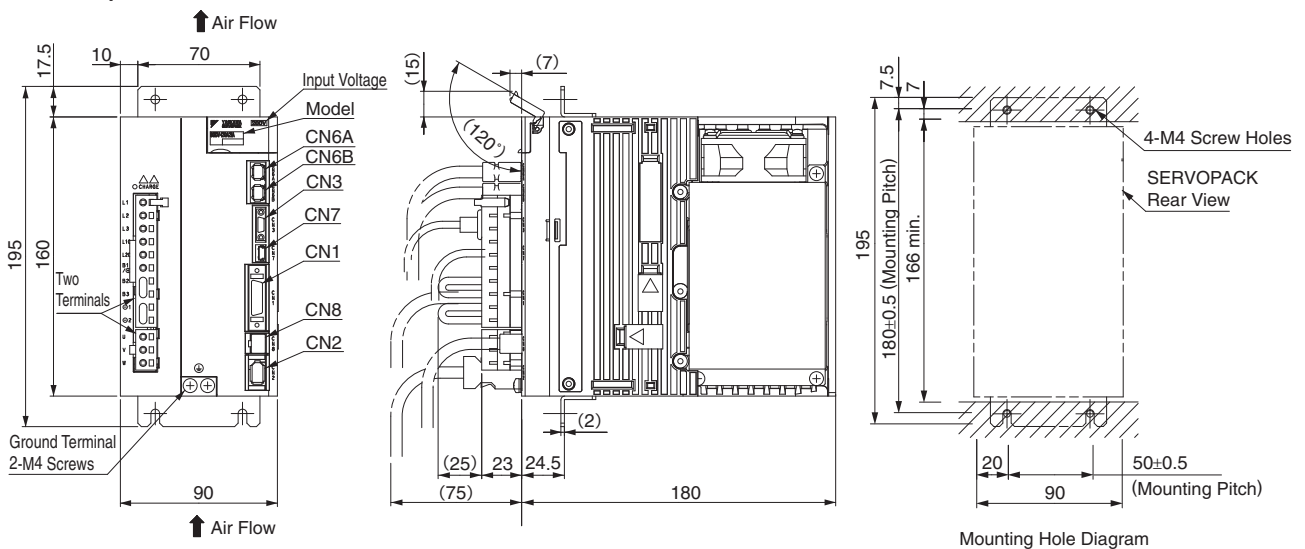

Approx. Mass: 2.5 kg

External Dimensions Units: mm

(7) Three-phase 200 VAC, Model: SGDV-180A2□A001 and -200A2□A001

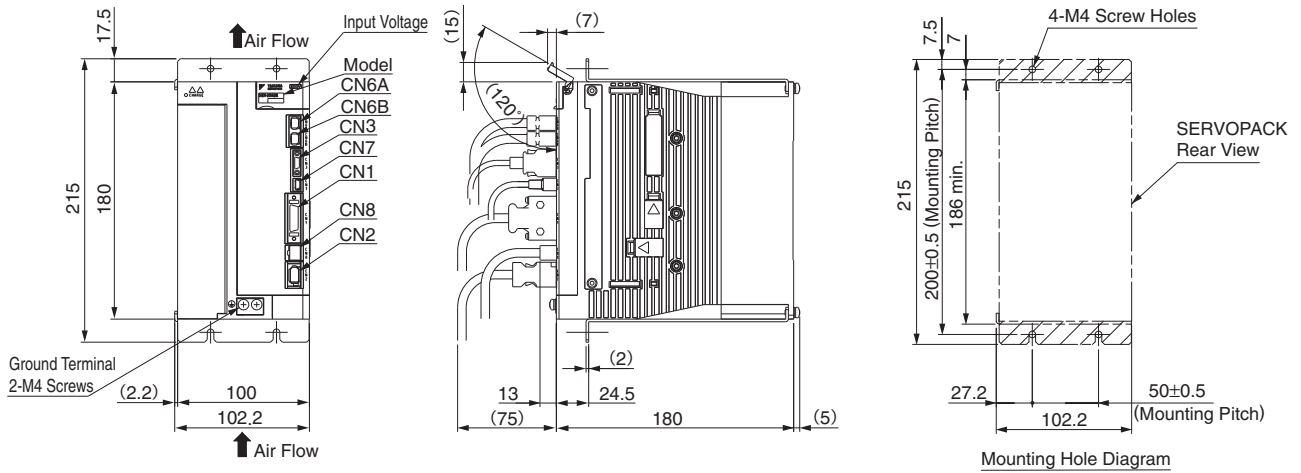

Approx. Mass: 3.1 kg

(8) Three-phase 200 VAC, Model: SGDV-330A2□A001

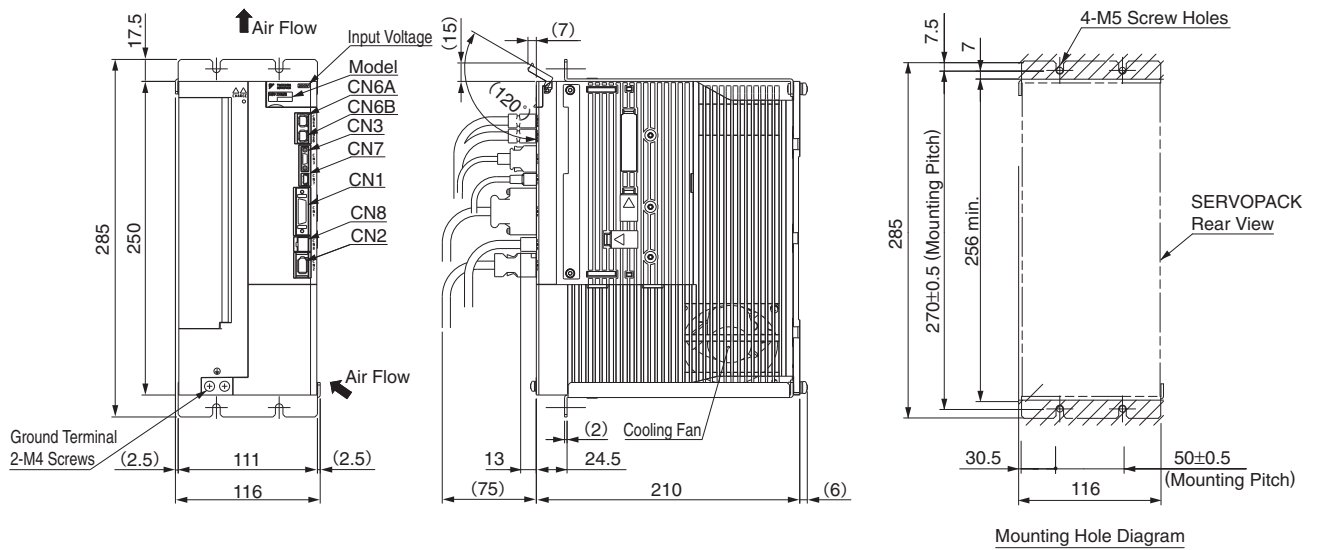

Approx. Mass: 5.0 kg

(9) Three-phase 400 VAC, Model: SGDV-1R9D2□A001, -3R5D2□A001, and -5R4D2□A001

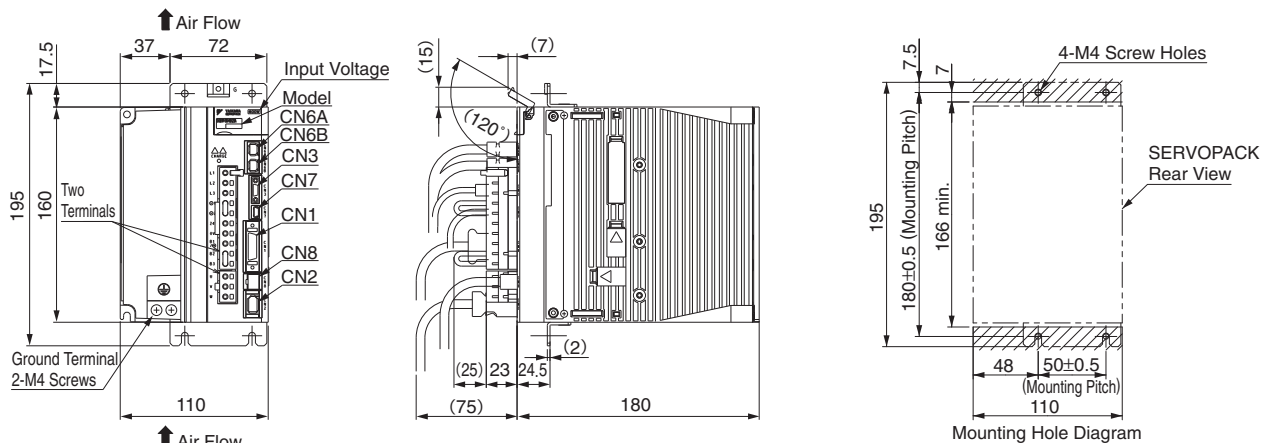

Approx. Mass: 2.7 kg

External Dimensions Units: mm

(10) Three-phase 400 VAC, Model: SGDV-8R4D2□A001 and -120D2□A001

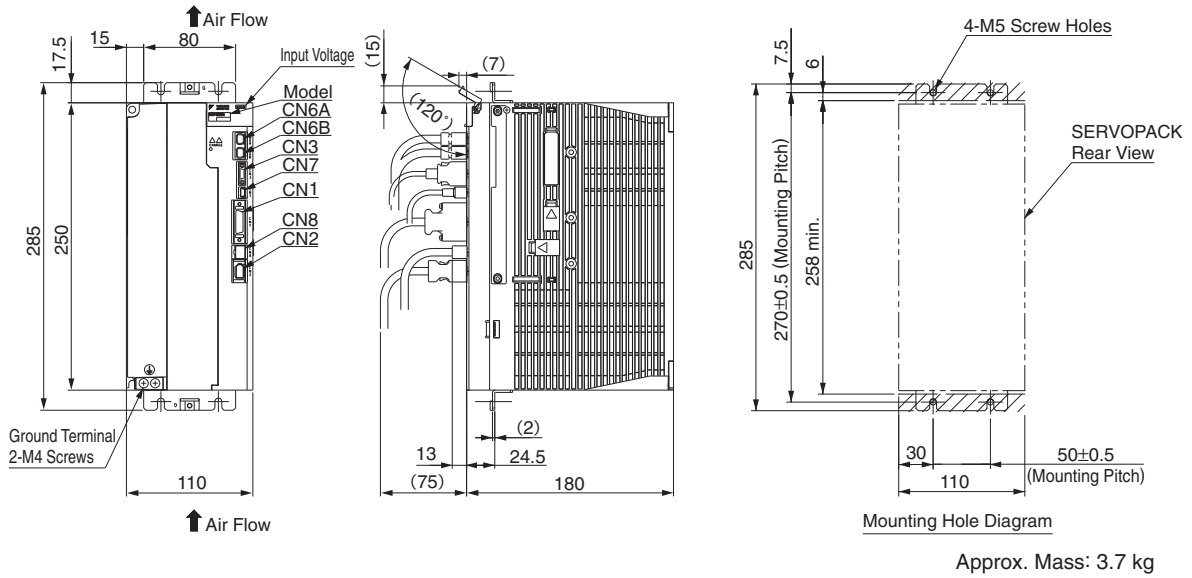

(11) Three-phase 400 VAC, Model: SGDV-170D2□A001

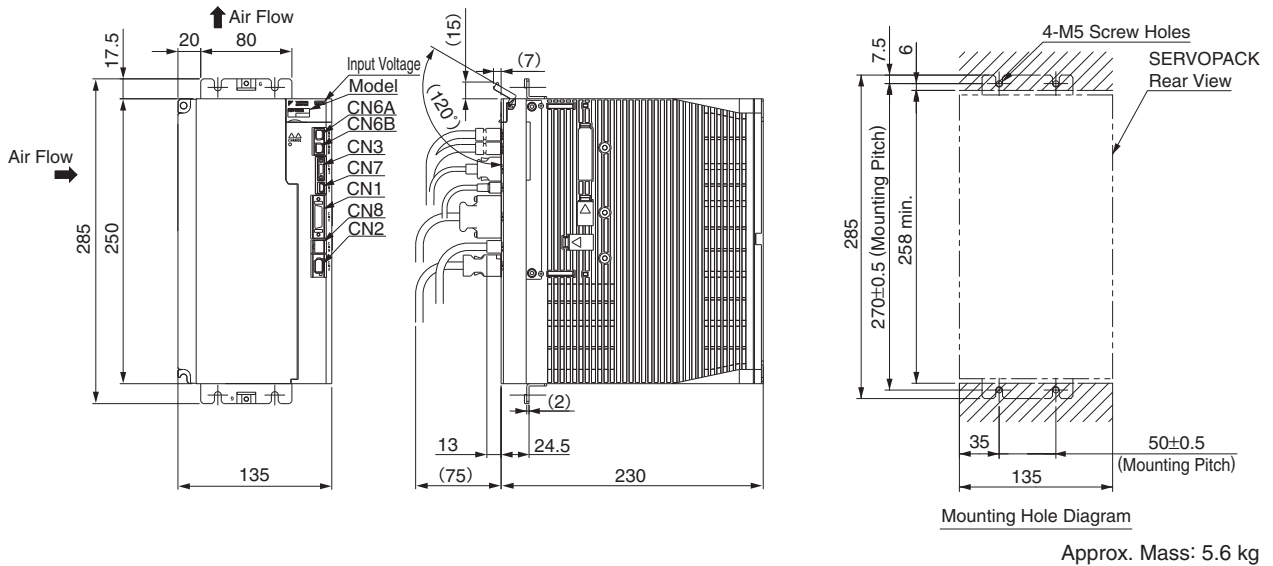

Connectors for Rack-mounted SERVOPACKs

Port	Model	Pin	Manufacturer
CN1	10226-52A2PL	26	Sumitomo 3M Ltd.
CN2	53984-0671	6	Molex Japan Co., Ltd.
CN3	HDR-EC14LFDTN-SLE-PLUS	14	Honda Tsushin Kogyo Co., Ltd.
CN6A	1981386-1	8	Tyco Electronics AMP K.K.
CN6B	1981386-1	8	Tyco Electronics AMP K.K.
CN7	MNC23-5K5H00	5	ADVANCED-CONNECTEK INC.
CN8	1981080-1	8	Tyco Electronics AMP K.K.

Note: The connectors above or their equivalents are used for SERVOPACKs.

Selecting Cables

● Cables for **CN1** **CN3** **CN5** **CN6** **CN7** **CN8** (MECHATROLINK-III Communications Reference Type SERVOPACKs)

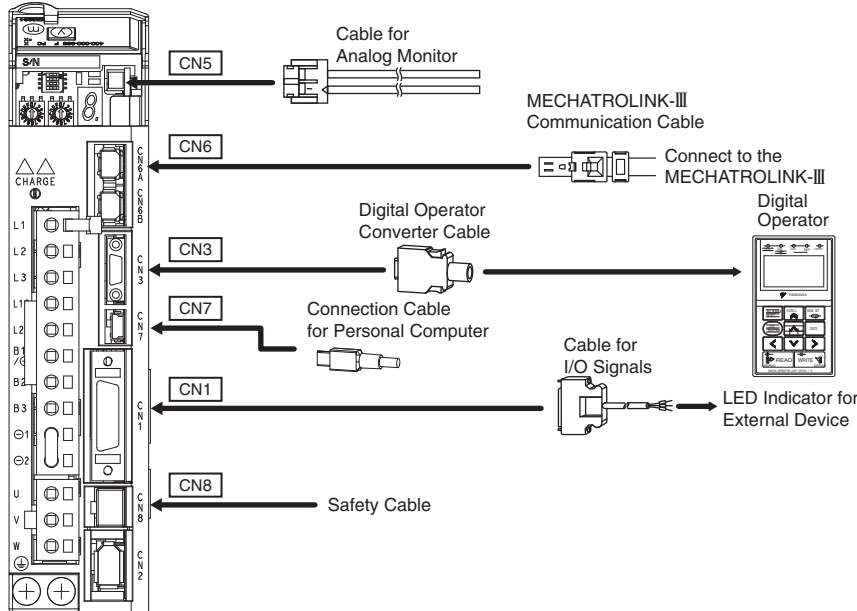

Name	Length	Order No.	Specifications	Details	
CN1 Cables for I/O Signals	Connector Kit	JZSP-CSI9-2-E	Soldered	(1)	
	Connector Terminal Converter Unit	JUSP-TA26P-E	Terminal Block and 0.5 m Connection Cable	(2)	
	Cable with Loose wire at One End	1 m	JZSP-CSI02-1-E		(3)
		2 m	JZSP-CSI02-2-E		
3 m		JZSP-CSI02-3-E			
CN3	Digital Operator	JUSP-OP05A-1-E	With Connection Cable (1 m)	(4)	
	Digital Operator Converter Cable*1	0.3 m	JZSP-CVS05-A3-E	Cable with Connectors at Both Ends	(5)
CN7 Connection Cables for Personal Computer	2.5 m	JZSP-CVS06-02-E	Cable with Connectors at Both Ends	(6)	
CN6A CN6B MECHATROLINK-III Communication Cable	Cables with Connectors at Both Ends (Without Ferrite Core)	0.2 to 50 m	JEPMC-W6012-□□-E	(7)	
	Cables with Connectors at Both Ends (With Ferrite Core)*2	10 to 75 m	JEPMC-W6013-□□-E	(8)	
	Cable with Loose Wire at One End	0.5 to 50 m	JEPMC-W6014-□□-E	(9)	
CN5 Cables for Analog Monitor	1 m	JZSP-CA01-E	SERVOPACK End	(10)	
CN8 Cables for Safety Functions	Cables with Connector*3	3 m	JZSP-CVH03-03-E	(11)	
	Connector kit*4	Contact Tyco Electronics AMP K.K. Product name : Industrial Mini I/O D-shape Type1 Plug Connector Kit Model : 2013595-1			

*1 : A converter cable is required to use Σ -III series digital operators (model: JUSP-OP05A) for Σ -V series SERVOPACKs.
 *2 : Currently in pre-release. Will be available soon.
 *3 : When using the safety function, connect this cable to the safety devices.
 Even when not using the safety function, use SERVOPACKs with the Safe Jumper Connector (model: JZSP-CVH05-E) connected.
 *4 : Use the connector kit when you make cables yourself.

Selecting Cables Units: mm

(1) Connector Kit for CN1

Use the following connector and cable to assemble the cable.
The CN1 connector kit includes one case and one connector.

Connector Kit Model	Case		Connector	
	Model	Qty	Model	Qty
JZSP-CSI9-2-E	10326-52A0-008*	1 set	10126-3000PE* (Soldered)	1

* : Manufactured by Sumitomo 3M Ltd.

• Cable Size

Item	Specifications
Cable	Use twisted-pair or twisted-pair shielded wire.
Applicable Wires	AWG24, 26, 28, 30
Cable Finished Diameter	16 dia. max.

• Dimensional Drawings of Case

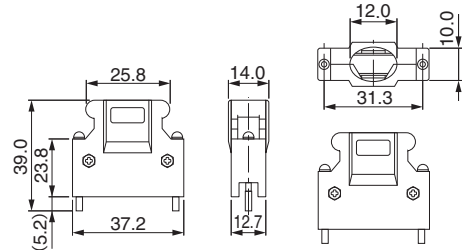

• Dimensional Drawings of Connector

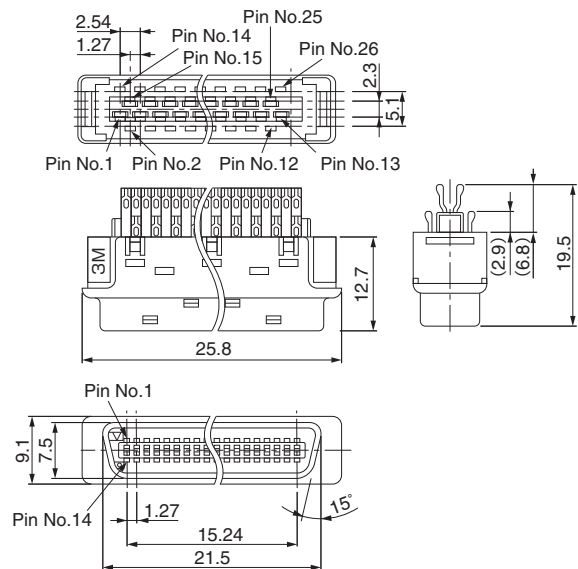

(2) Connector Terminal Converter Unit for CN1

• Configurations

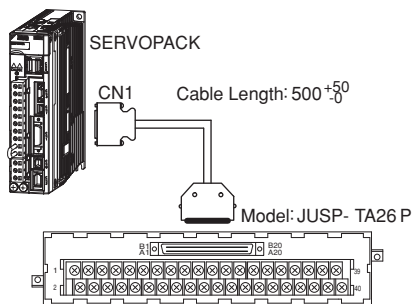

• Dimensional Drawings of Terminal Block

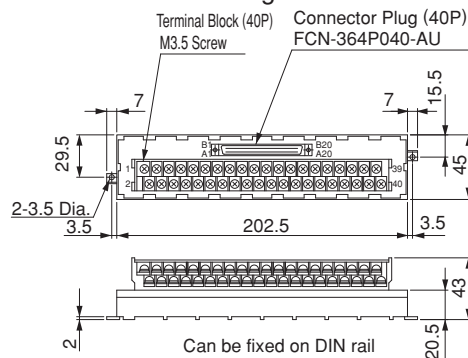

• Dimensional Drawings of Cable

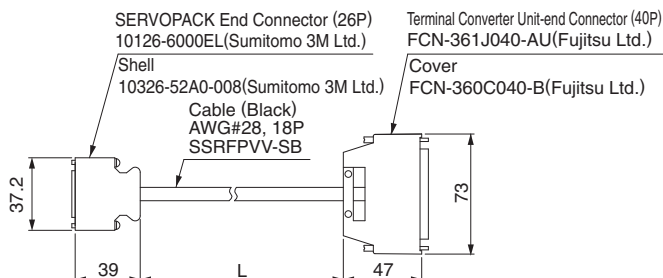

Model	Cable Length (L)	Approx. Mass
JUSP-TA26P-E	0.5 m	100 g
JUSP-TA26P-1-E	1 m	200 g
JUSP-TA26P-2-E	2 m	400 g

Selecting Cables Units: mm

(3) Cable with Loose Wires at One End for CN1
Dimensional Drawings of Cable

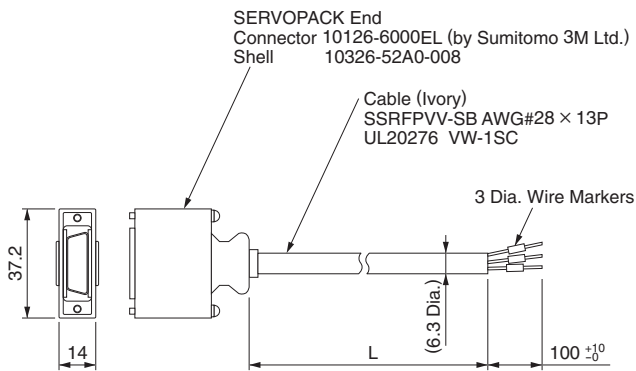

Model	Cable Length
JZSP-CSI02-1-E	1 m
JZSP-CSI02-2-E	2 m
JZSP-CSI02-3-E	3 m

● Cable with Loose Wires at One End for CN1
Connection Diagram of JZSP-CSI02-□-E Cable

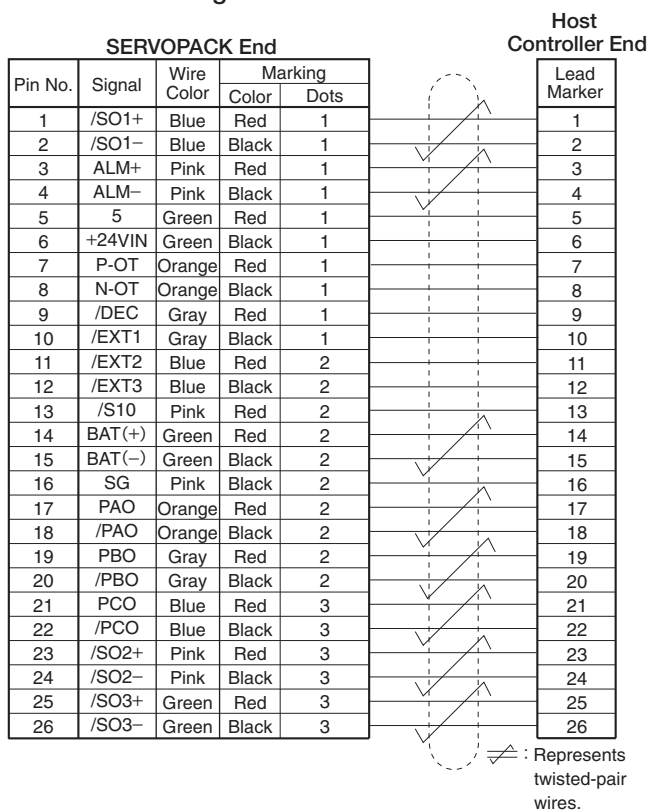

(4) Digital Operator (Model: JUSP-OP05A-1-E)

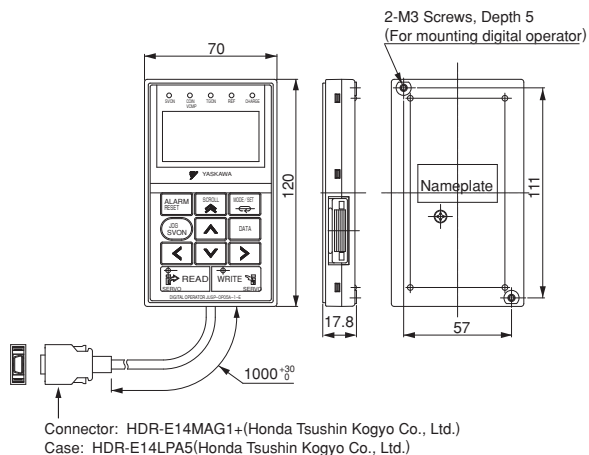

(5) Digital Operator Converter Cable for CN3
(Model: JZSP-CVS05-A3-E)

A converter cable is required to use Σ-V series digital operators (model: JUSP-OP05A) for Σ-V series SERVOPACKs.

• Dimensional Drawings

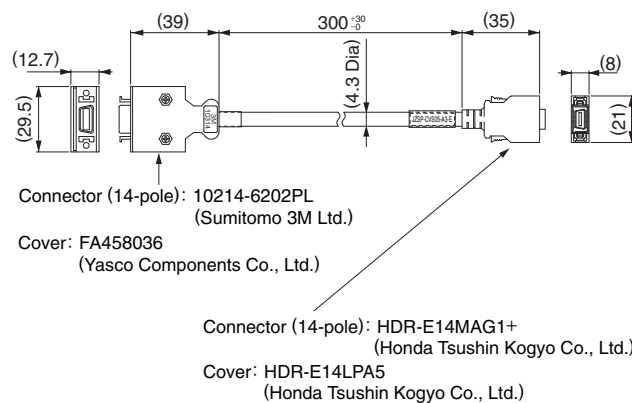

Selecting Cables Units: mm

(6) Connection Cable for Personal Computer for CN7 (Model: JZSP-CVS06-02-E)

- Dimensional Drawings

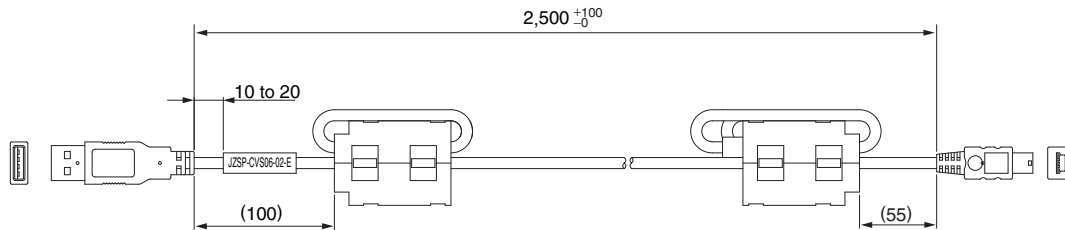

IMPORTANT Use a cable specified by Yaskawa.
When using other cables, operation cannot be guaranteed.

(7) MECHATROLINK-III Communications Cable for CN6 (Model: JEPMC-W6012-□□-E)

- Dimensional Drawings

Cables with Connectors at Both Ends (Without Ferrite Core)

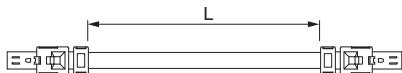

Model	Cable Length (L)
JEPMC-W6012-A2-E	0.2 m
JEPMC-W6012-A5-E	0.5 m
JEPMC-W6012-01-E	1 m
JEPMC-W6012-02-E	2 m
JEPMC-W6012-03-E	3 m
JEPMC-W6012-04-E	4 m
JEPMC-W6012-05-E	5 m
JEPMC-W6012-10-E	10 m
JEPMC-W6012-20-E	20 m
JEPMC-W6012-30-E	30 m
JEPMC-W6012-50-E	50 m

(8) MECHATROLINK-III Communications Cable for CN6 (Model: JEPMC-W6013-□□-E)

- Dimensional Drawings

Cables with Connectors at Both Ends (With Ferrite Core)

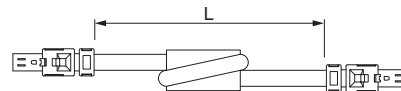

Model	Cable Length (L)
JEPMC-W6013-10-E	10 m
JEPMC-W6013-20-E	20 m
JEPMC-W6013-30-E	30 m
JEPMC-W6013-50-E	50 m
JEPMC-W6013-75-E	75 m

(9) MECHATROLINK-III Communications Cable for CN6 (Model: JEPMC-W6014-□□-E)

- Dimensional Drawings

Cable with Loose Wire at One End

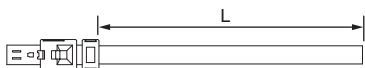

Model	Cable Length (L)
JEPMC-W6014-A5-E	0.5 m
JEPMC-W6014-01-E	1 m
JEPMC-W6014-03-E	3 m
JEPMC-W6014-05-E	5 m
JEPMC-W6014-10-E	10 m
JEPMC-W6014-30-E	30 m
JEPMC-W6014-50-E	50 m

IMPORTANT Use a MECHATROLINK-III communications cable specified by Yaskawa. When using other cables, noise resistance may be reduced, and operation cannot be guaranteed.

Selecting Cables Units: mm

(10) Cable for Analog Monitor for CN5 (Model: JZSP-CA01-E)

· Dimensional Drawings

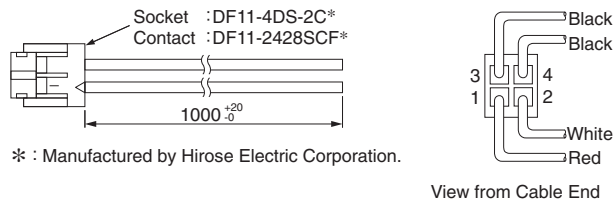

* : Manufactured by Hirose Electric Corporation.

· Specifications

Pin No.	Cable Color	Signal	Standard Settings
1	Red	Analog Monitor 2	Motor speed : 1V/1000 min ⁻¹
2	White	Analog Monitor 1	Torque reference : 1V/100% rated torque
3, 4	Black (2 cables)	GND(0V)	—

Note : The specifications above are factory settings. Monitor specifications can be changed by changing parameters Pn006 and Pn007.

(11) Cable with Connector for CN8 (Model: JZSP-CVH03-03-E)

· Dimensional Drawings

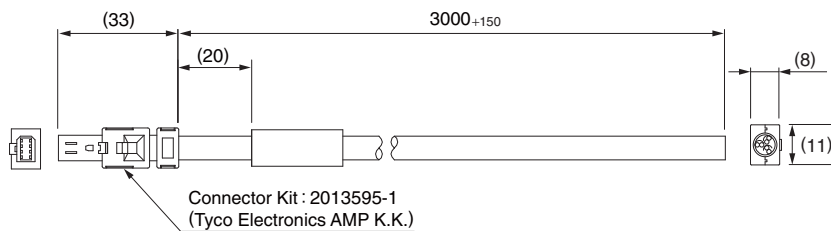

· Specifications

Pin No.	Signal	Lead Color	Marking Color
1	Not used	—	—
2	Not used	—	—
3	/HWBB1-	White	Black
4	/HWBB1+	White	Red
5	/HWBB2-	Gray	Black
6	/HWBB2+	Gray	Red
7	EDM1-	Orange	Black
8	EDM1+	Orange	Red

SERVOPACK with Option Module



Model Designations

SGDV^(Note) R70 A 01 A 000 00 0 001

Σ-V Series
SGDV SERVOPACK

Current

Voltage	Code	Applicable Servomotor Max. Capacity kW
100 V	R70	0.05
	R90	0.1
	2R1	0.2
	2R8	0.4
200 V	R70	0.05
	R90	0.1
	1R6	0.2
	2R8	0.4
	3R8	0.5
	5R5	0.75
	7R6	1.0
	120	1.5
	180	2.0
	200	3.0
	330	5.0
	470	6.0
550	7.5	
590	11	
780	15	

Voltage

Code	Specifications
F	100 VAC
A	200 VAC

Option Module

Code	Specifications
001	Option module for fully-closed loop control

Options (parameter)

Code	Specifications
0	standard

Options (software)

Code	Specifications
00	standard

Options (hardware)

Code	Specifications
000	Base-mounted (standard)
001	Rack-mounted
002	Varnished
003	Rack-mounted and Varnished

Design Revision Order
A, B...

Interface

Code	Specifications
01	Analog voltage/pulse train reference type (for rotary servomotors)
05	Analog voltage/pulse train reference type (for linear servomotors)
11	MECHATROLINK- II communications reference type (for rotary servomotors)
15	MECHATROLINK- II communications reference type (for linear servomotors)
21	MECHATROLINK- III communications reference type (for rotary servomotors)
25	MECHATROLINK- III communications reference type (for linear servomotors)

Note: The model number of a SERVOPACK with option modules is not hyphenated after SGDV.

Features

- Superlative expandability achieved by option module method.
 - (1) Option Module 1 (reference)*: compatible with various communication interfaces.
 - (2) Option Module 2 (safety)*: compatible with EN60204-1 stop category 1 and 2 (stop category 0 is standard)
 - (3) Option Module 3 (feedback): compatible with fully-closed loop control

*: Under development.

Precautions

<Combination Example>

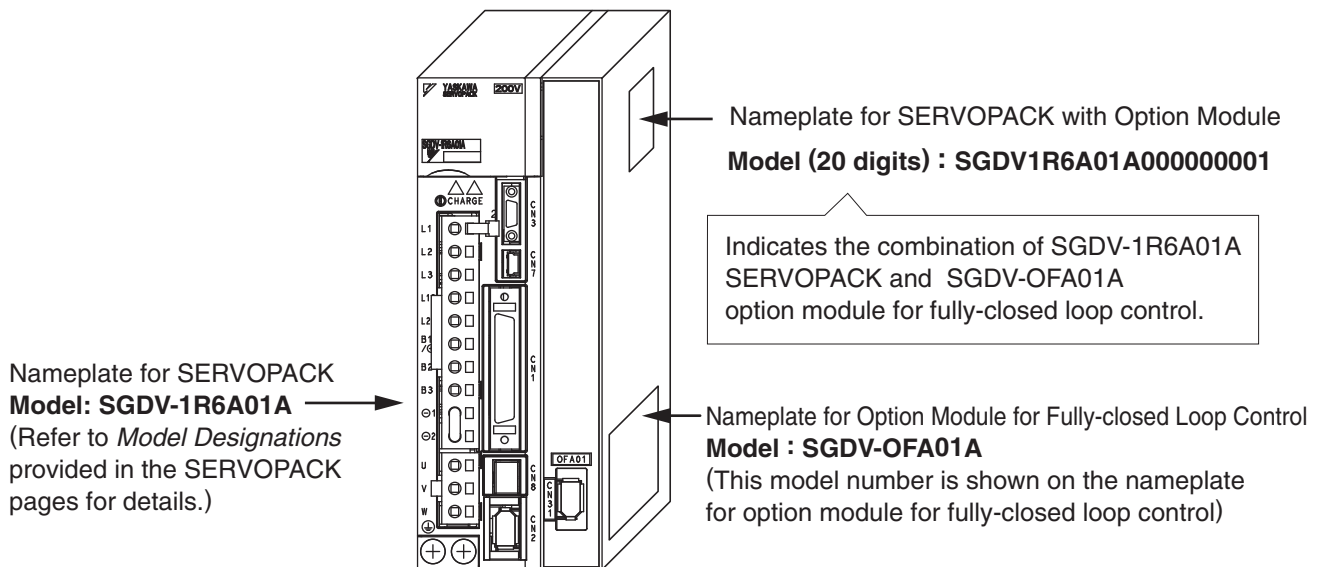

External Dimensions Units: mm (for Analog Voltage/Pulse Train Reference Type SERVOPACKs)

The following drawings illustrate the external dimensions of SERVOPACKs with option modules. For option module details, refer to *Option Module for Fully-closed Loop Control* on page 339.

● Base-mounted SERVOPACKs

(1) Single-phase 100 VAC, Model:SGDVR70F0□A00000001, SGDVR90F0□A00000001, and SGDV2R1F0□A00000001

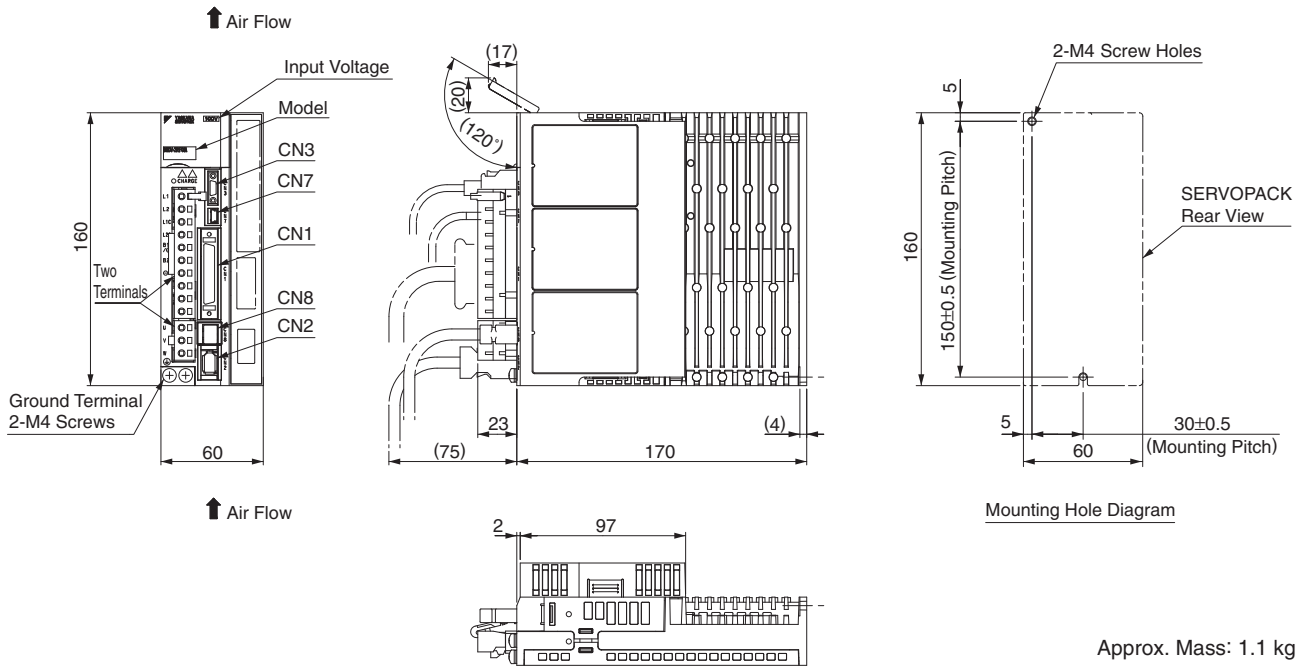

(2) Single-phase 100 VAC, Model: SGDV2R8F0□A00000001

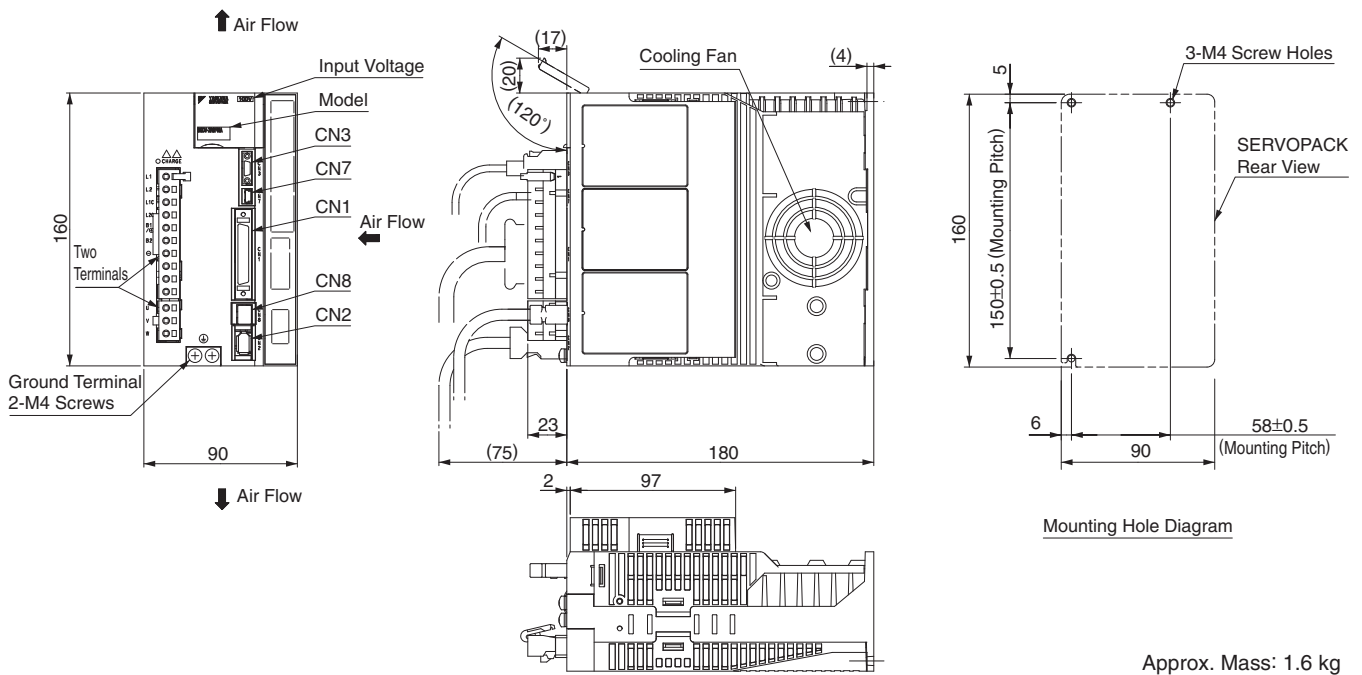

External Dimensions Units: mm (for Analog Voltage/Pulse Train Reference Type SERVOPACKs)

(3) Three-phase 200 VAC, Model: SGDVR70A0□A00000001, SGDVR90A0□A00000001, and SGDVR6A0□A00000001

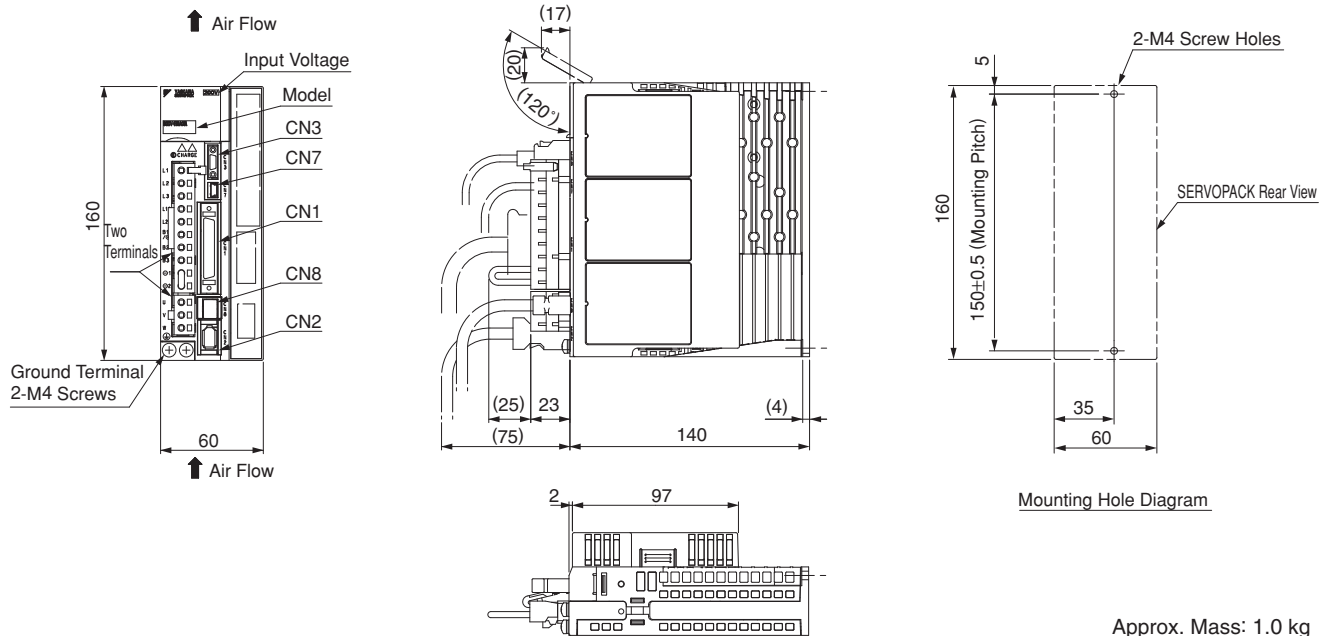

(4) Three-phase 200 VAC, Model: SGDV2R8A0□A00000001

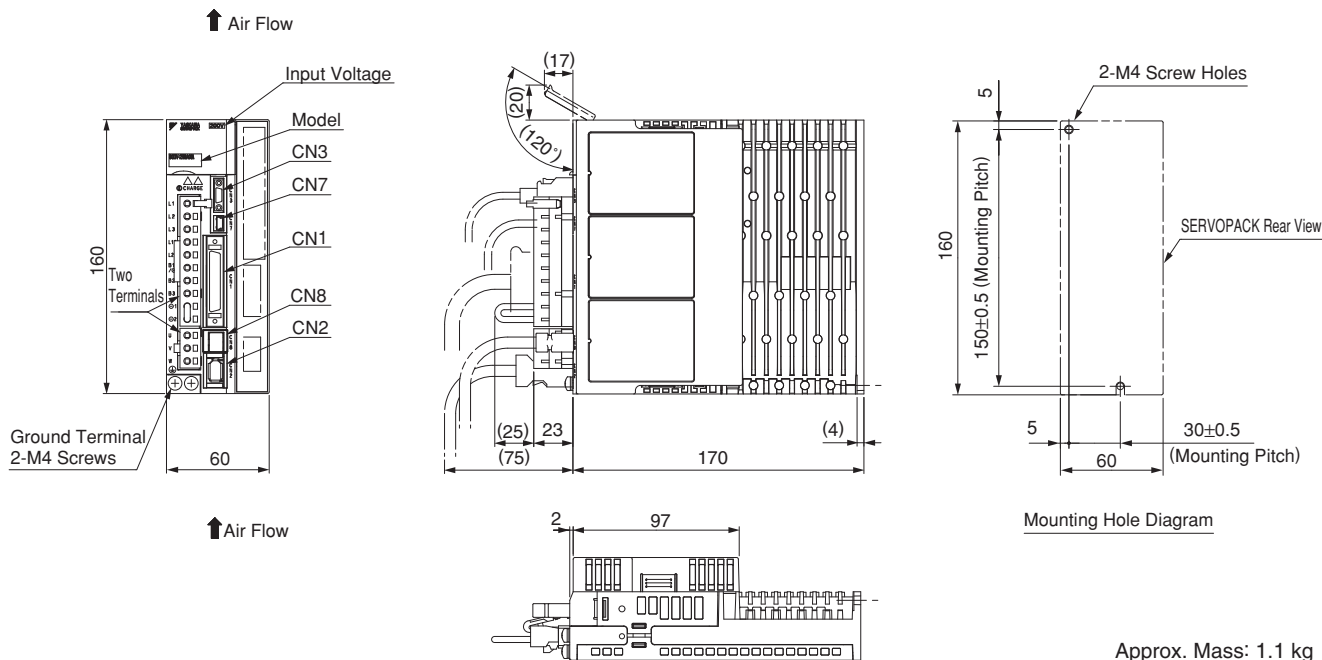

External Dimensions Units: mm (for Analog Voltage/Pulse Train Reference Type SERVOPACKs)

(5) Three-phase 200 VAC, Model: SGDV3R8A0□A00000001, SGDV5R5A0□A00000001, and SGDV7R6A0□A00000001

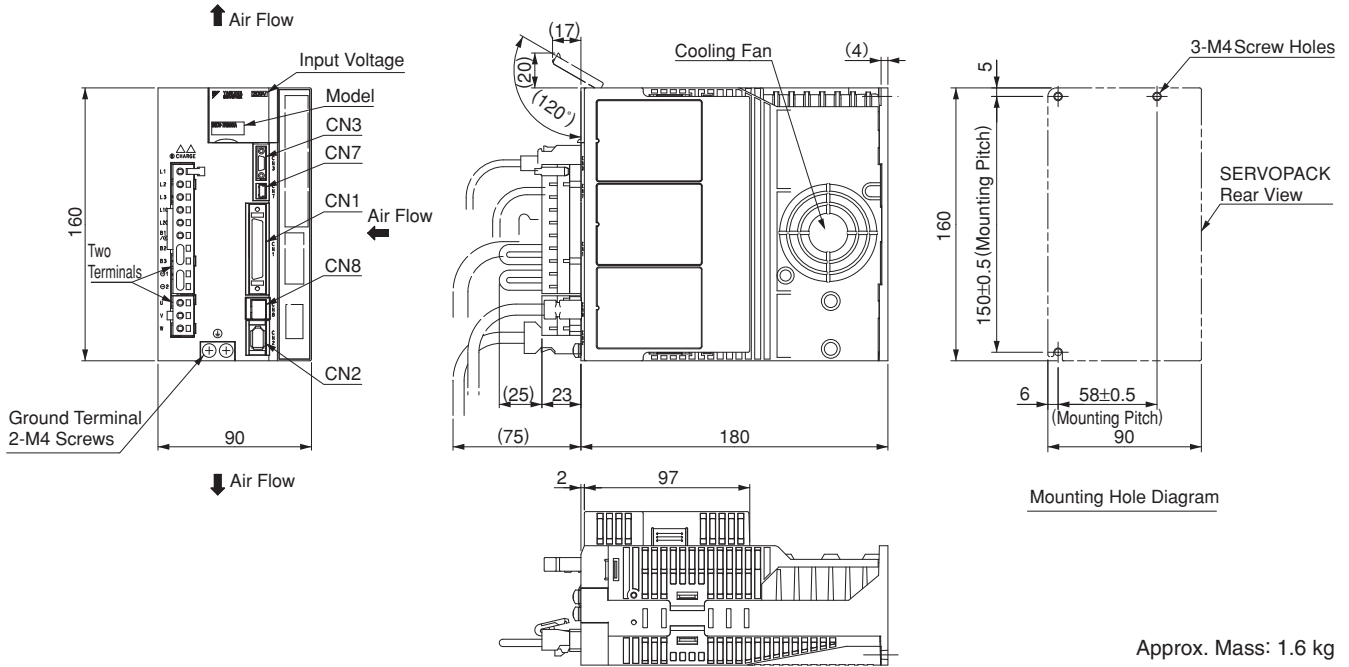

(6) Three-phase 200 VAC, Model: SGDV120A0□A00000001

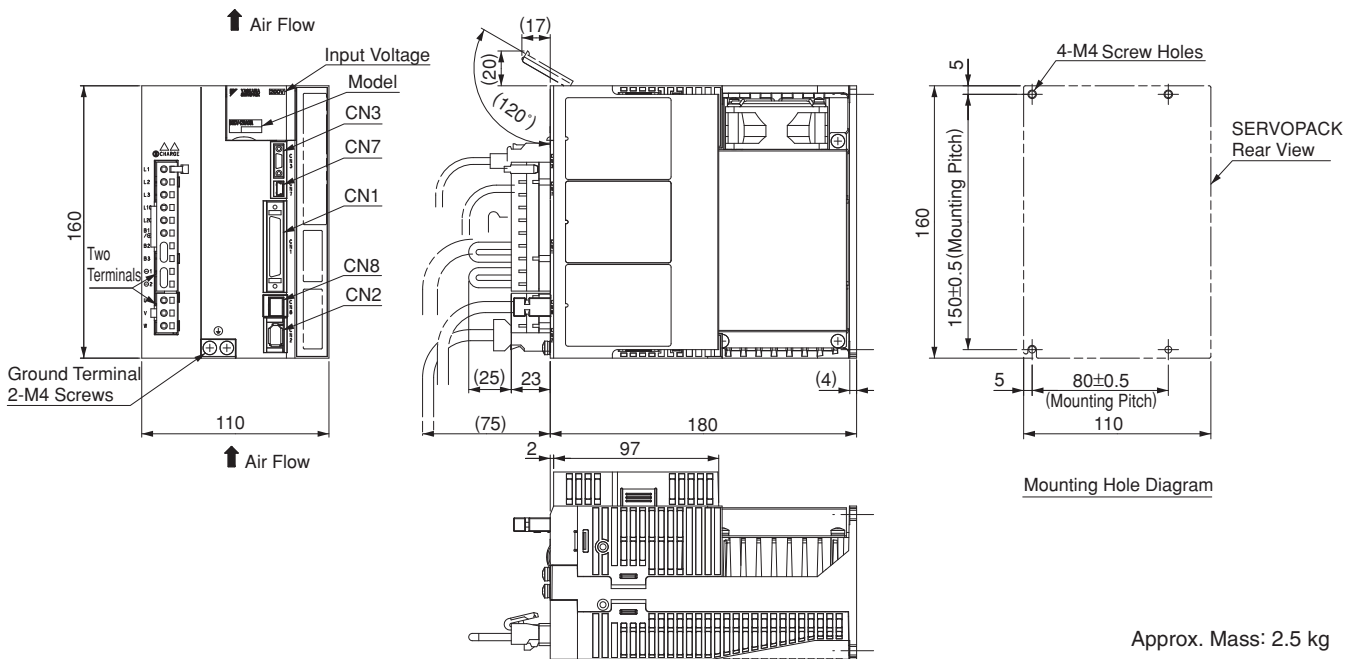

External Dimensions Units: mm (for Analog Voltage/Pulse Train Reference Type SERVOPACKs)

(7) Three-phase 200 VAC, Model: SGD180A0□A00000001, and SGD200A0□A00000001

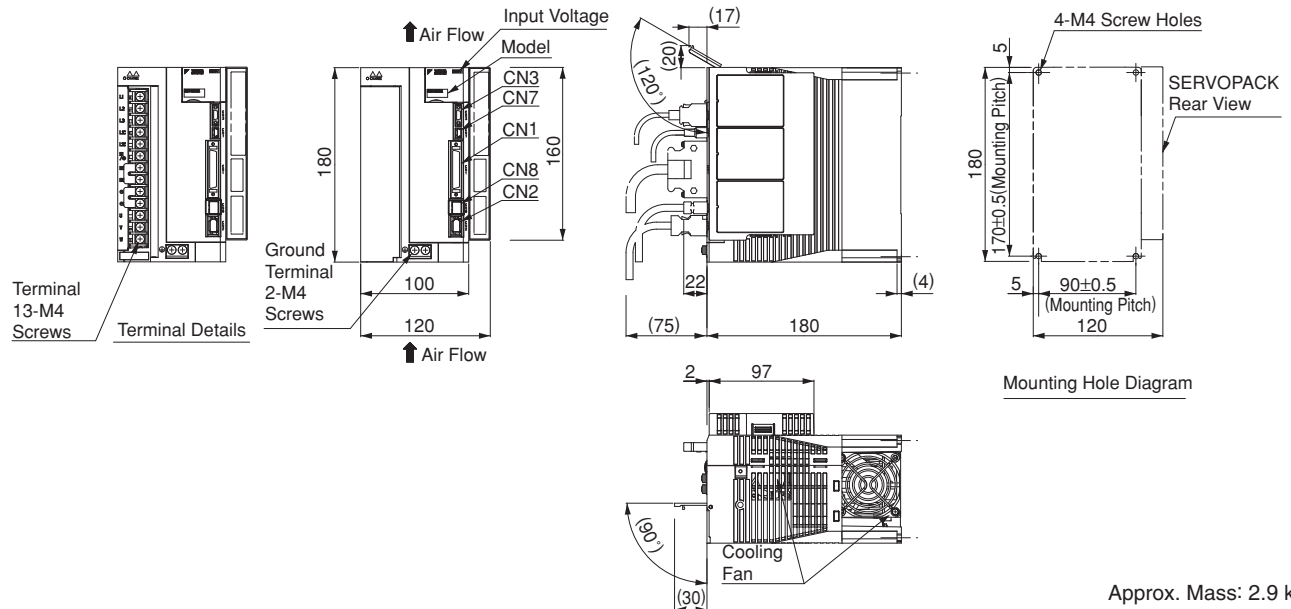

(8) Three-phase 200 VAC, Model: SGD330A0□A00000001

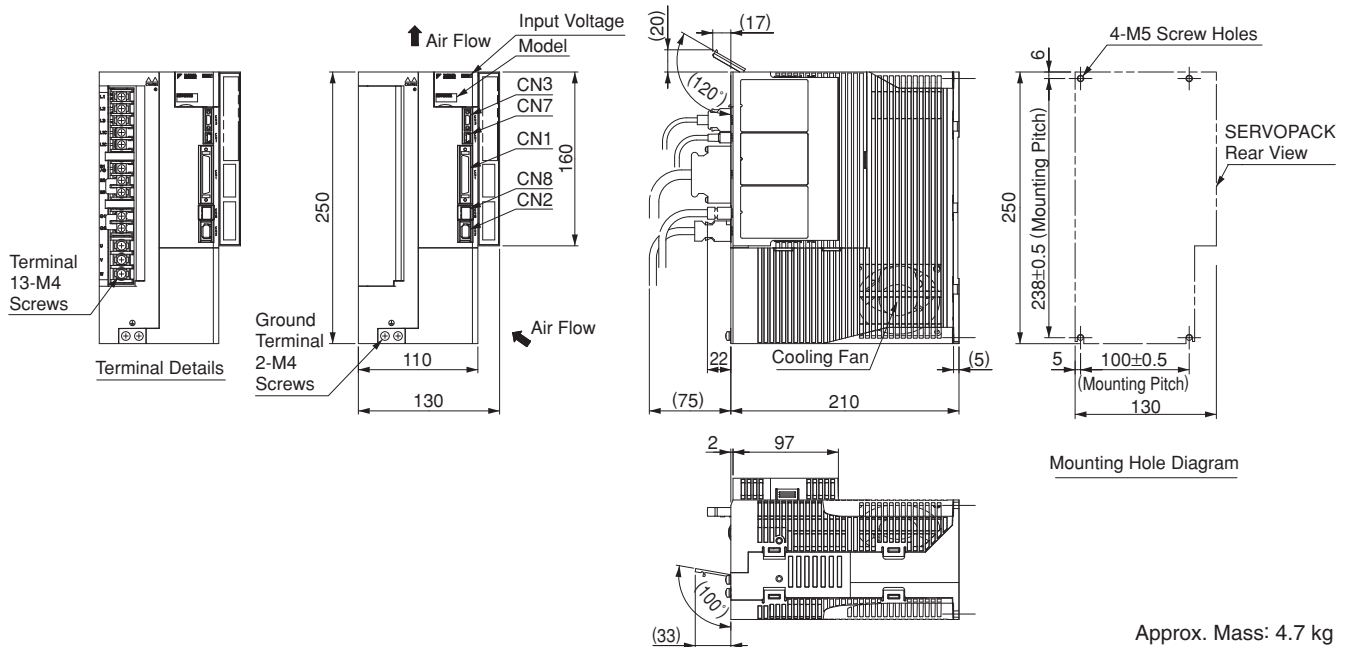

Connectors for Base-mounted SERVOPACKs

Port	Model	Pin	Manufacturer
CN1	10250-52A2PL	50	Sumitomo 3M Ltd.
CN2	53984-0671	6	Molex Japan Co., Ltd.
CN3	HDR-EC14LFDTN-SLE-PLUS	14	Honda Tsushin Kogyo Co., Ltd.
CN7	MNC23-5K5H00	5	ADVANCED-CONNECTEK INC.
CN8	1981080-1	8	Tyco Electronics AMP K.K.

Note: The connectors above or their equivalents are used for SERVOPACKs.

External Dimensions Units: mm (for Analog Voltage/Pulse Train Reference Type SERVOPACKs)

● **Rack-mounted SERVOPACKs**

(1) Single-phase 100 VAC, Model: SGDVR70F0□A001000001, SGDVR90F0□A001000001, and SGDVR1F0□A001000001

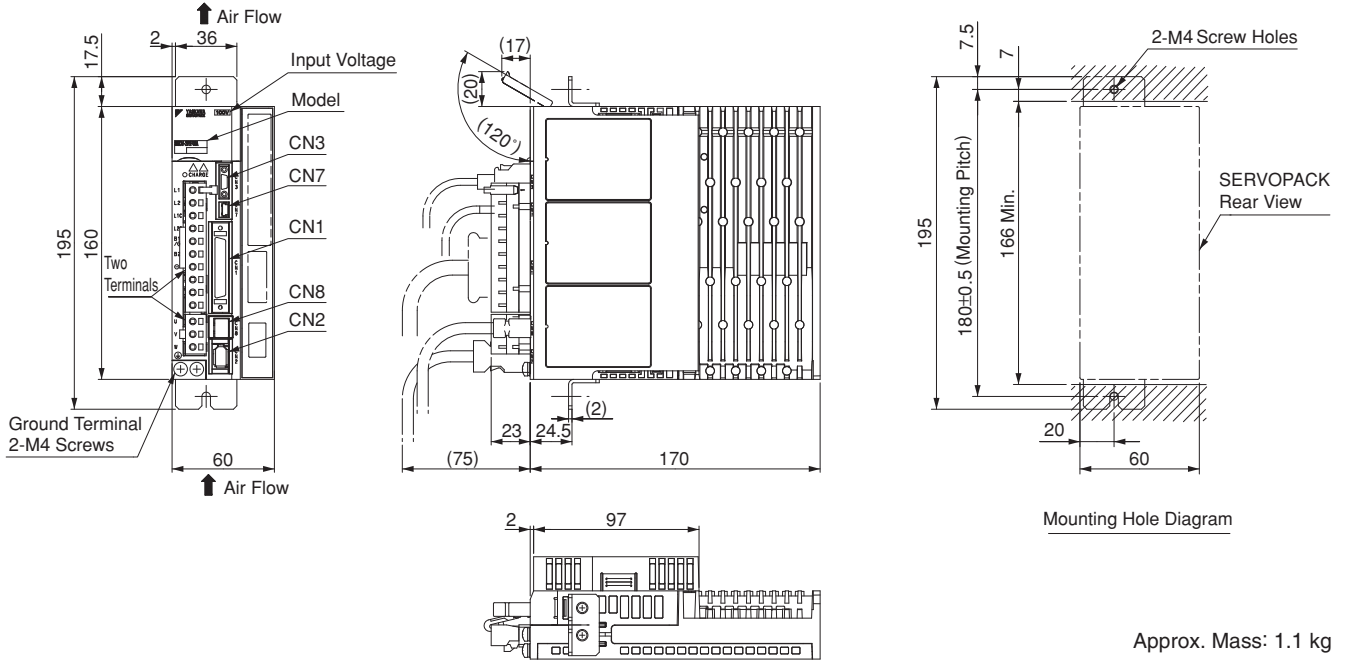

(2) Single-phase 100 VAC, Model: SGDVR2R8F0□A001000001

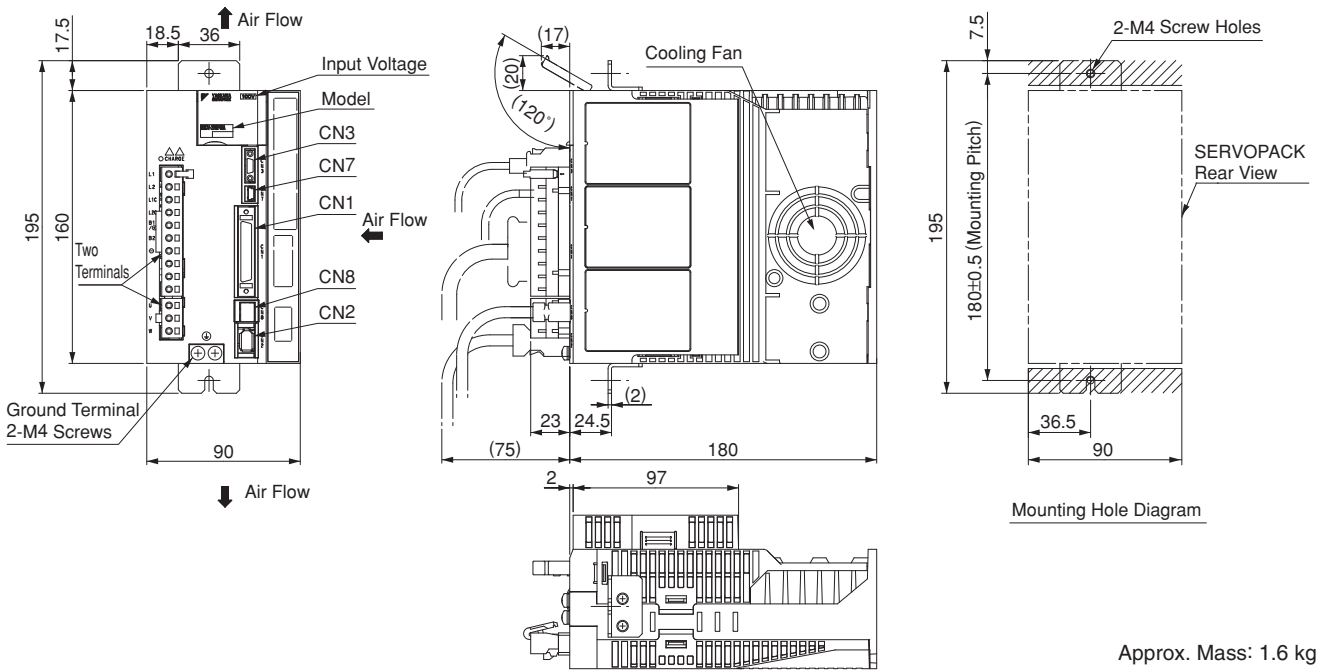

External Dimensions Units: mm (for Analog Voltage/Pulse Train Reference Type SERVOPACKs)

(3) Three-phase 200 VAC, Model: SGDVR70A0□A001000001, SGDVR90A0□A001000001, and SGD1R6A0□A001000001

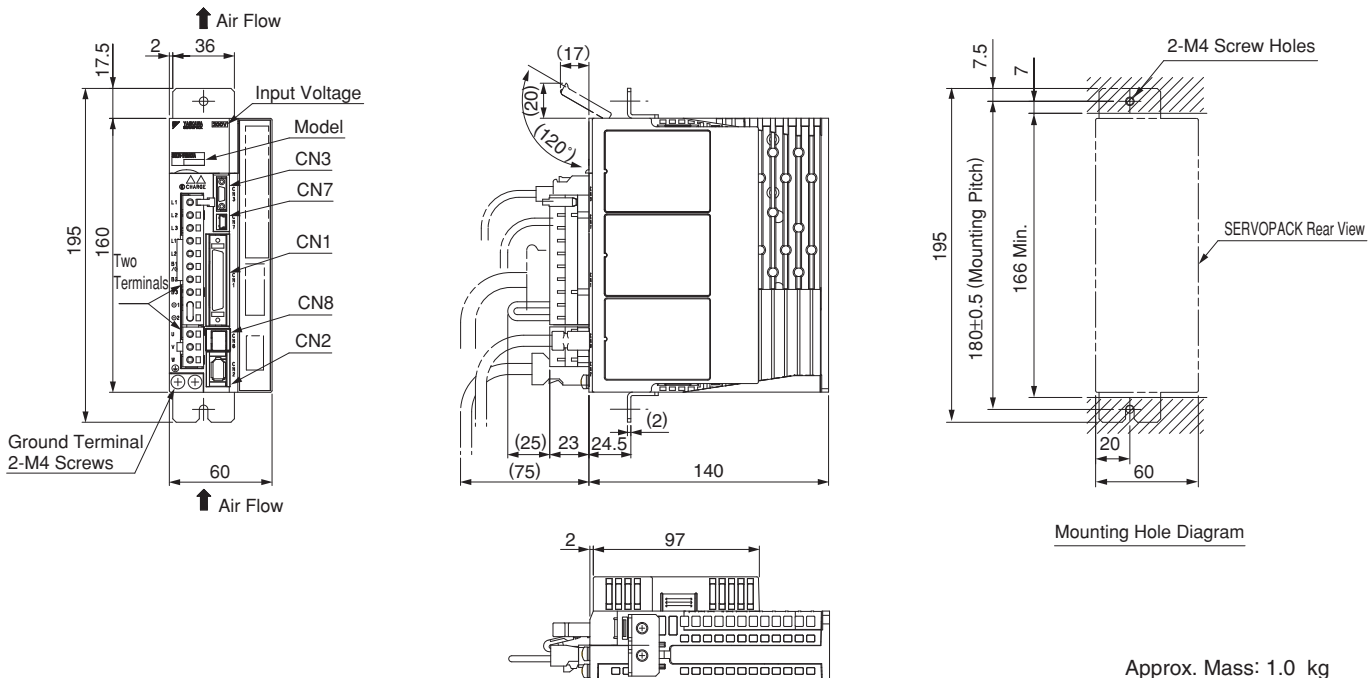

(4) Three-phase 200 VAC, Model: SGDV2R8A0□A001000001

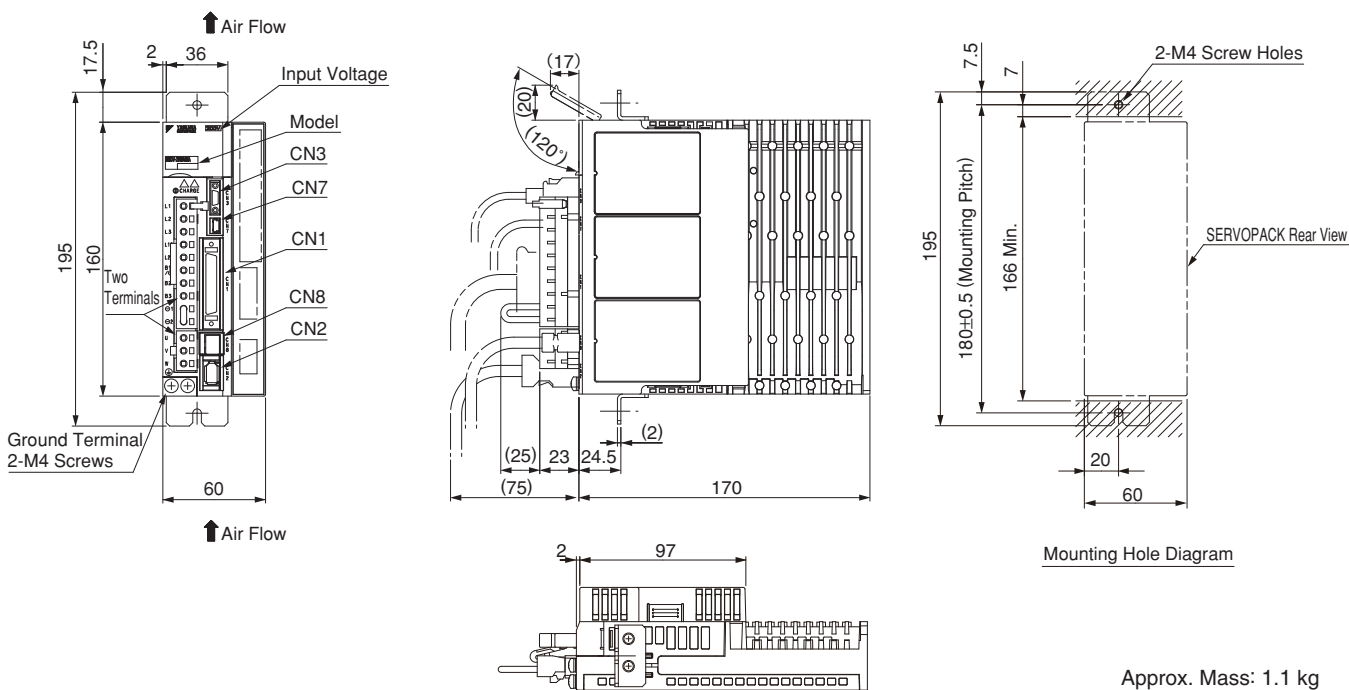

External Dimensions Units: mm (for Analog Voltage/Pulse Train Reference Type SERVOPACKs)

(5) Three-phase 200 VAC, Model: SGD3R8A0□A001000001, SGD5R5A0□A001000001, and SGD7R6A0□A001000001

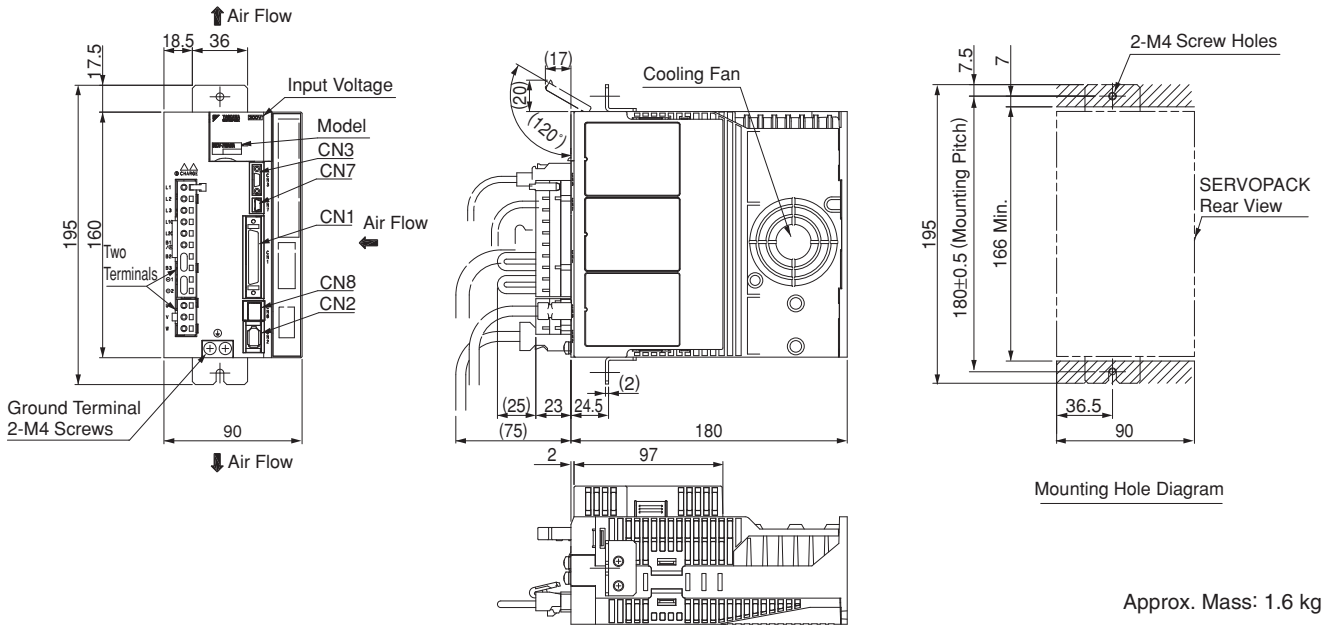

(6) Three-phase 200 VAC, Model: SGD120A0□A001000001

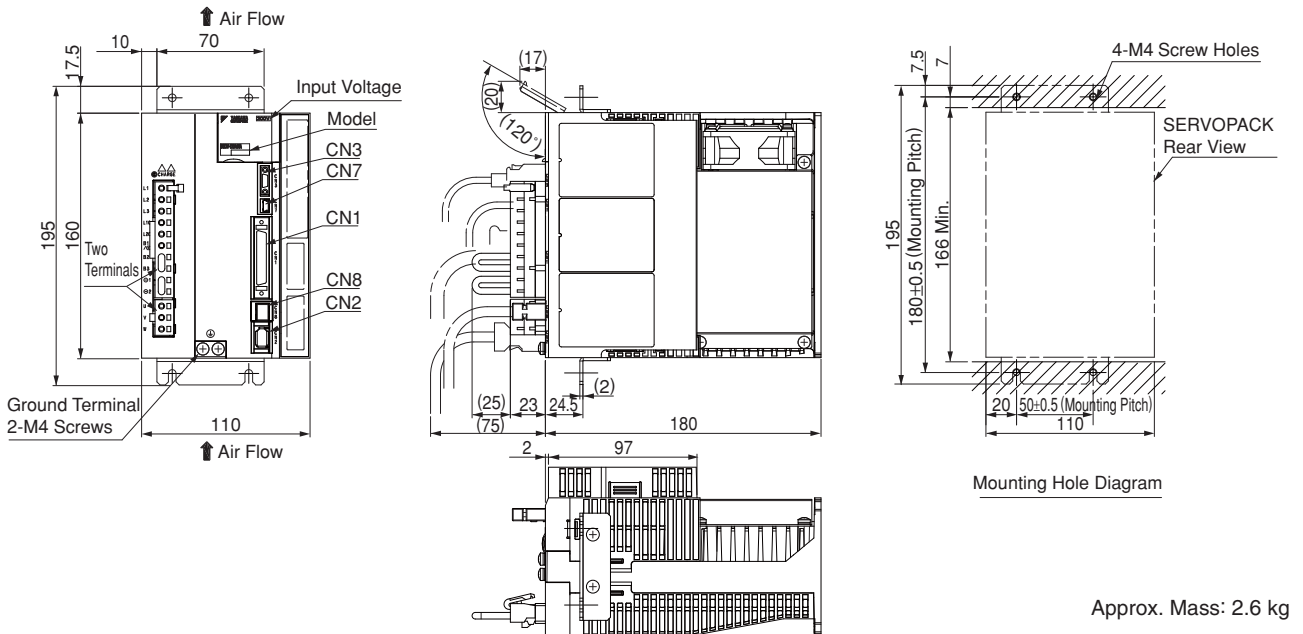

External Dimensions Units: mm (for Analog Voltage/Pulse Train Reference Type SERVOPACKs)

(7) Three-phase 200 VAC, Model: SGD180A0□A001000001, and SGD200A0□A001000001

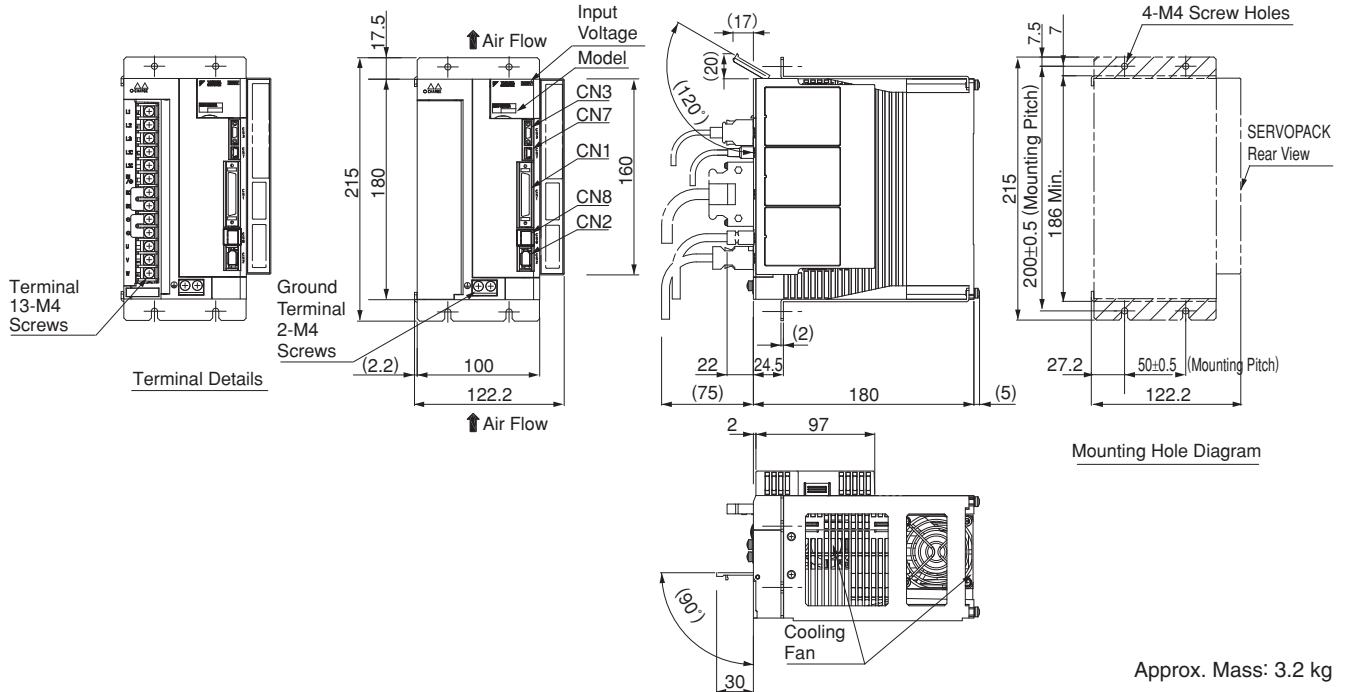

(8) Three-phase 200 VAC, Model: SGD330A0□A001000001

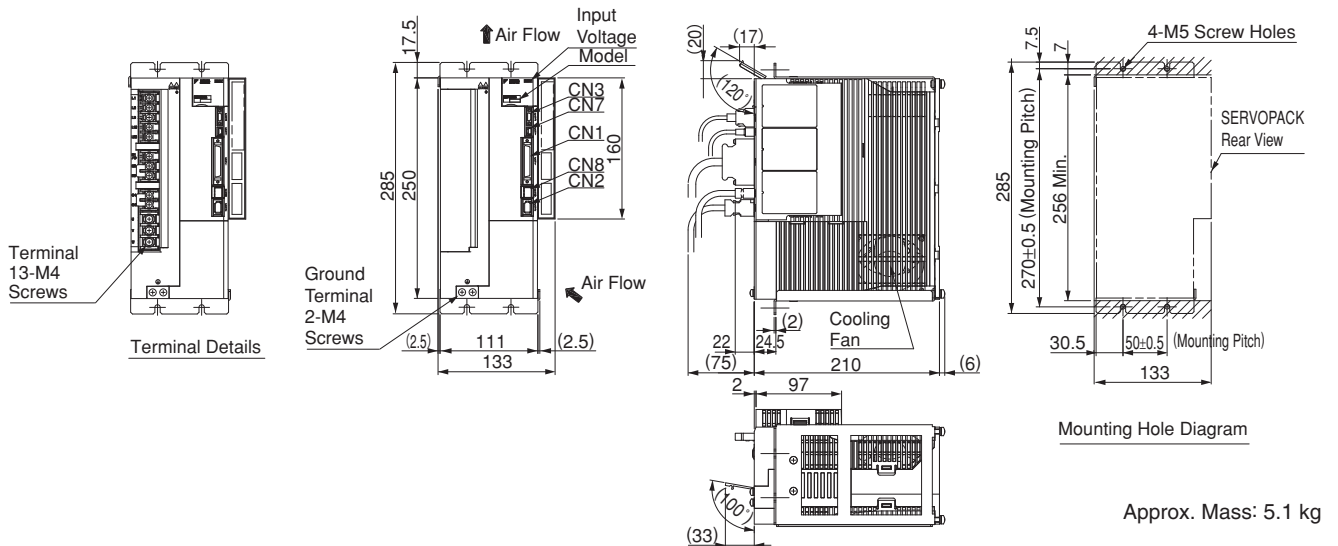

Connectors for Rack-mounted SERVOPACKs

Port	Model	Pin	Manufacturer
CN1	10250-52A2PL	50	Sumitomo 3M Ltd.
CN2	53984-0671	6	Molex Japan Co., Ltd.
CN3	HDR-EC14LFDTN-SLE-PLUS	14	Honda Tsushin Kogyo Co., Ltd.
CN7	MNC23-5K5H00	5	ADVANCED-CONNECTEK INC.
CN8	1981080-1	8	Tyco Electronics AMP K.K.

Note: The connectors above or their equivalents are used for SERVOPACKs.

External Dimensions Units: mm (for MECHATROLINK-II Communications Reference Type SERVOPACKs)

● **Base-mounted SERVOPACKs**

(1) Single-phase 100 VAC, Model: SGDVR70F1 □ A00000001, SGDVR90F1 □ A00000001, and SGDVR2R1F1 □ A00000001

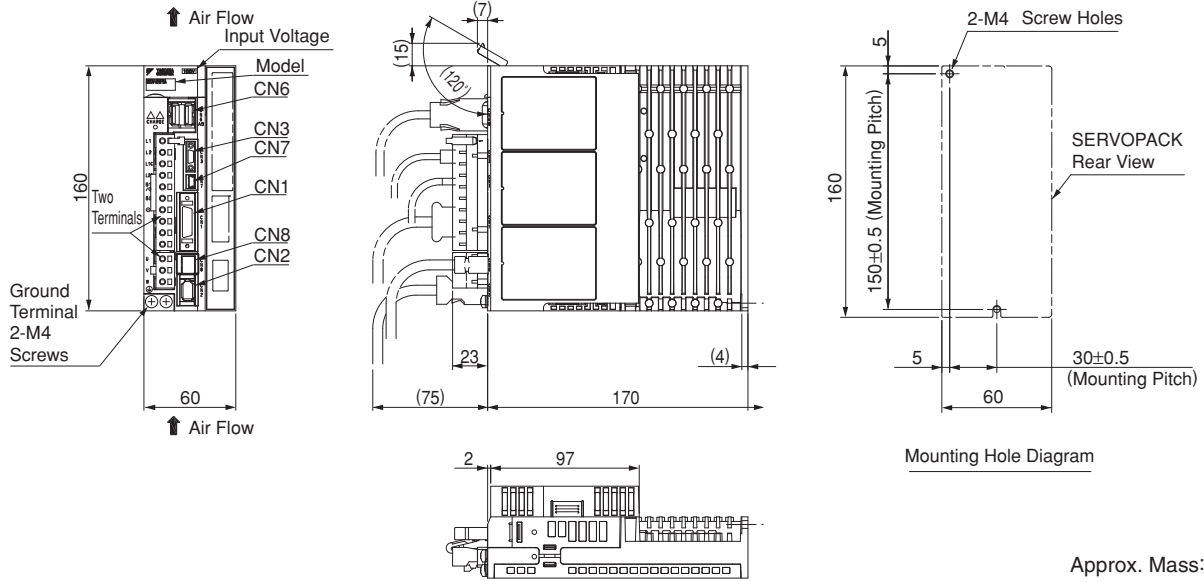

(2) Single-phase 100 VAC, Model: SGDV2R8F1 □ A00000001

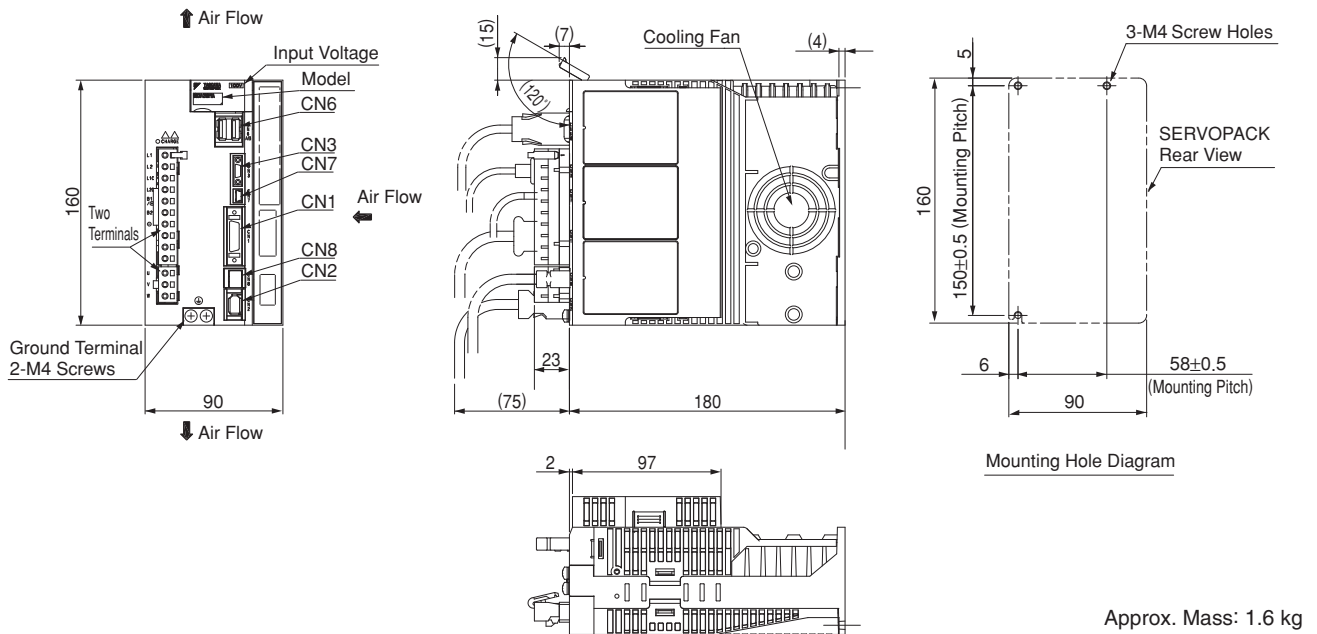

External Dimensions Units: mm (for MECHATROLINK-II Communications Reference Type SERVOPACKs)

(3) Three-phase 200 VAC, Model: SGDVR70A1□A00000001, SGDVR90A1□A00000001, and SGDVR6A1□A00000001

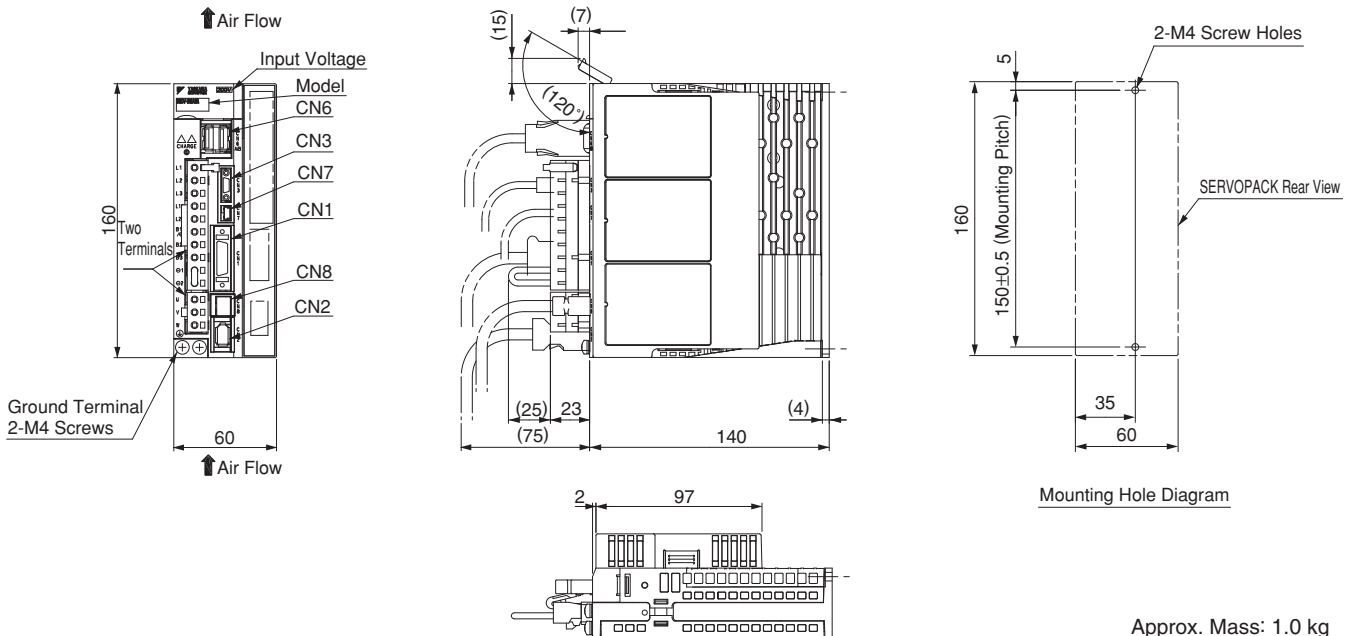

(4) Three-phase 200 VAC, Model: SGDV2R8A1□A00000001

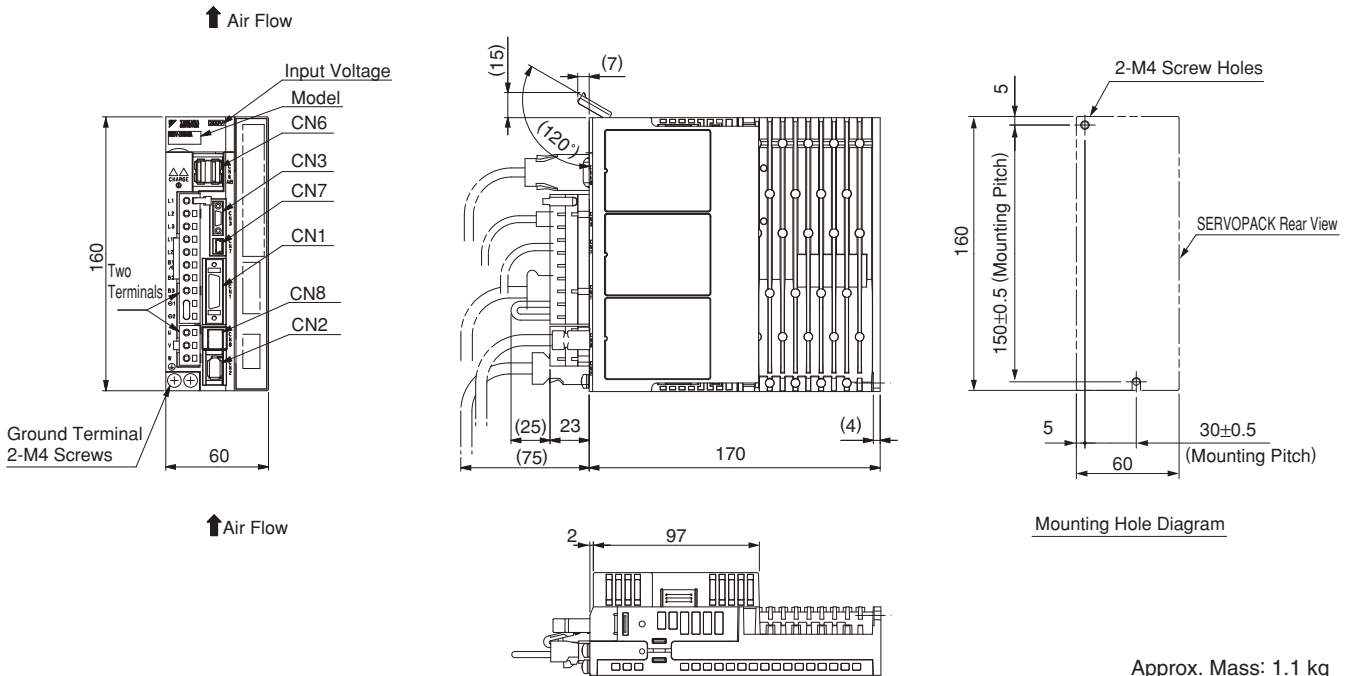

External Dimensions Units: mm (for MECHATROLINK-II Communications Reference Type SERVOPACKs)

(5) Three-phase 200 VAC, Model: SGDV3R8A1□A00000001, SGDV5R5A1□A00000001, and SGDV7R6A1□A00000001

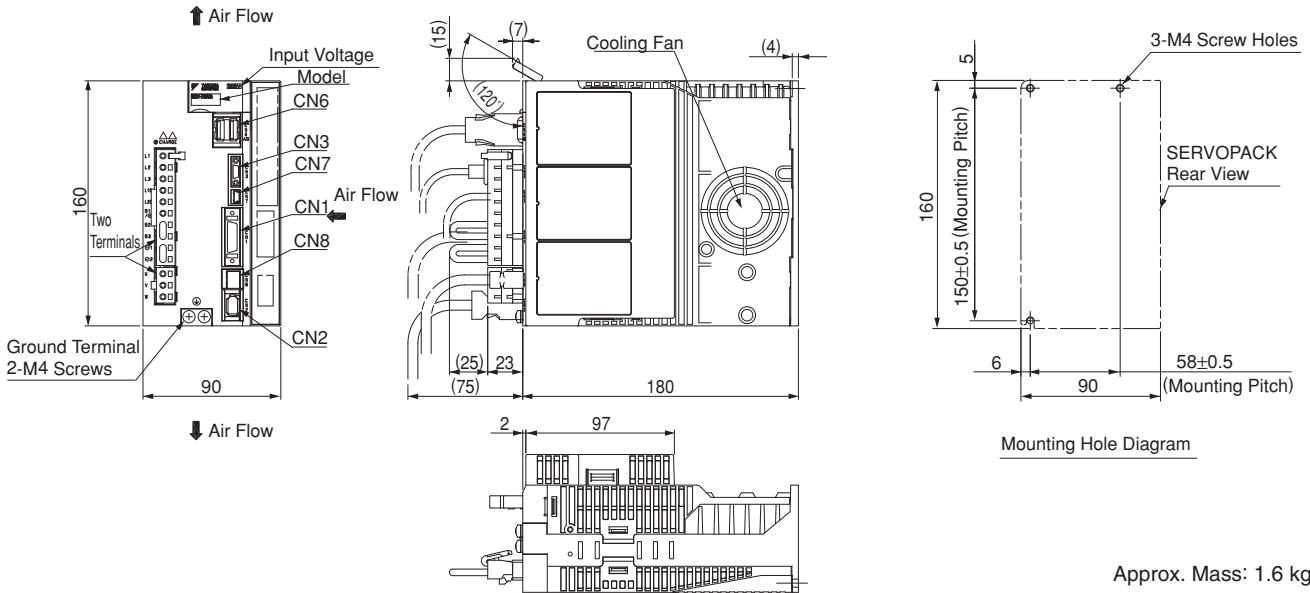

(6) Three-phase 200 VAC, Model: SGDV120A1□A00000001

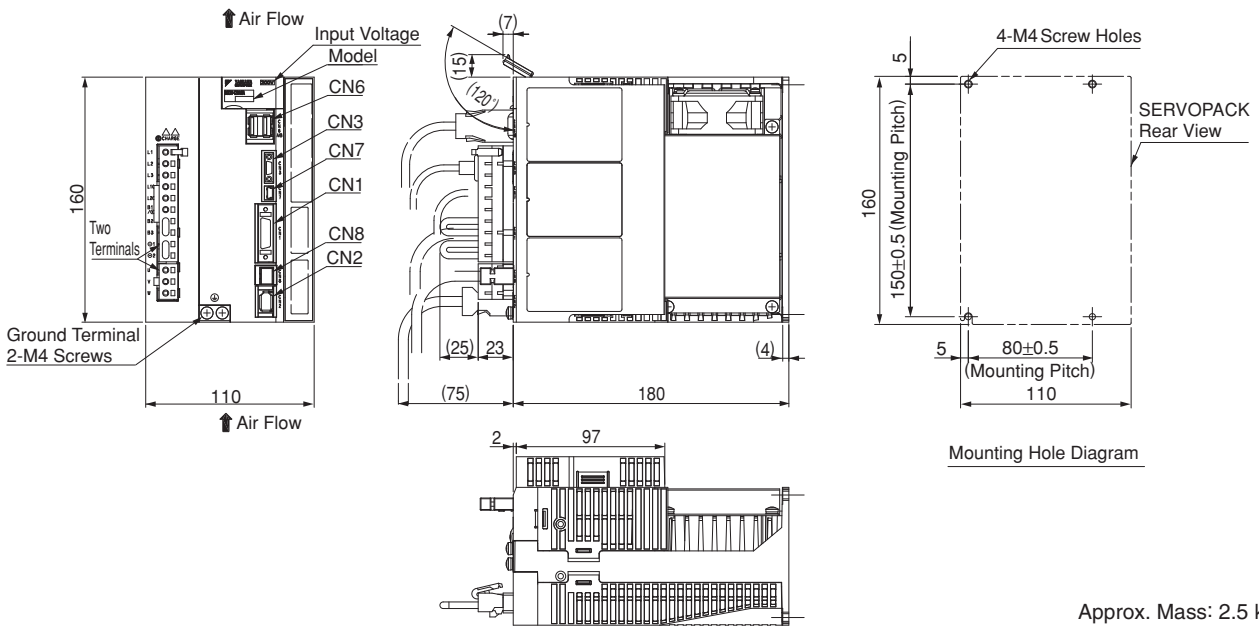

External Dimensions Units: mm (for MECHATROLINK-II Communications Reference Type SERVOPACKs)

(7) Three-phase 200 VAC, Model: SGDV180A1□A00000001, and SGDV200A1□A00000001

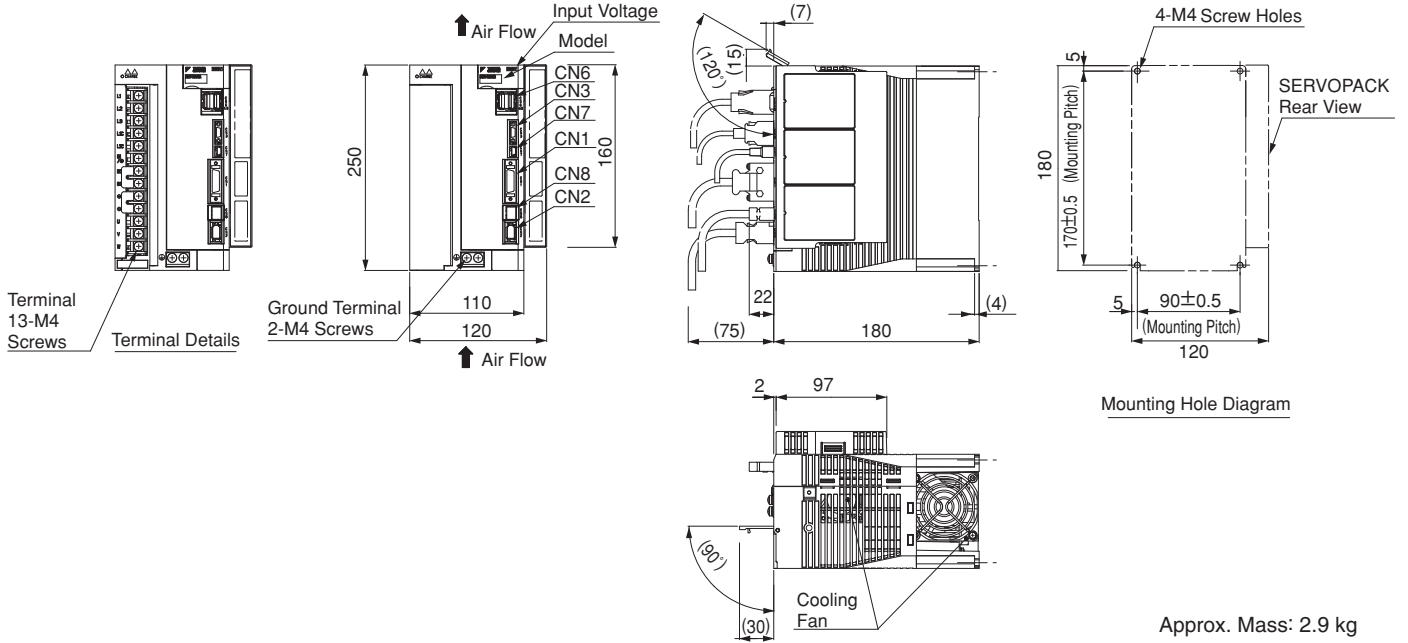

(8) Three-phase 200 VAC, Model: SGDV330A1□A00000001

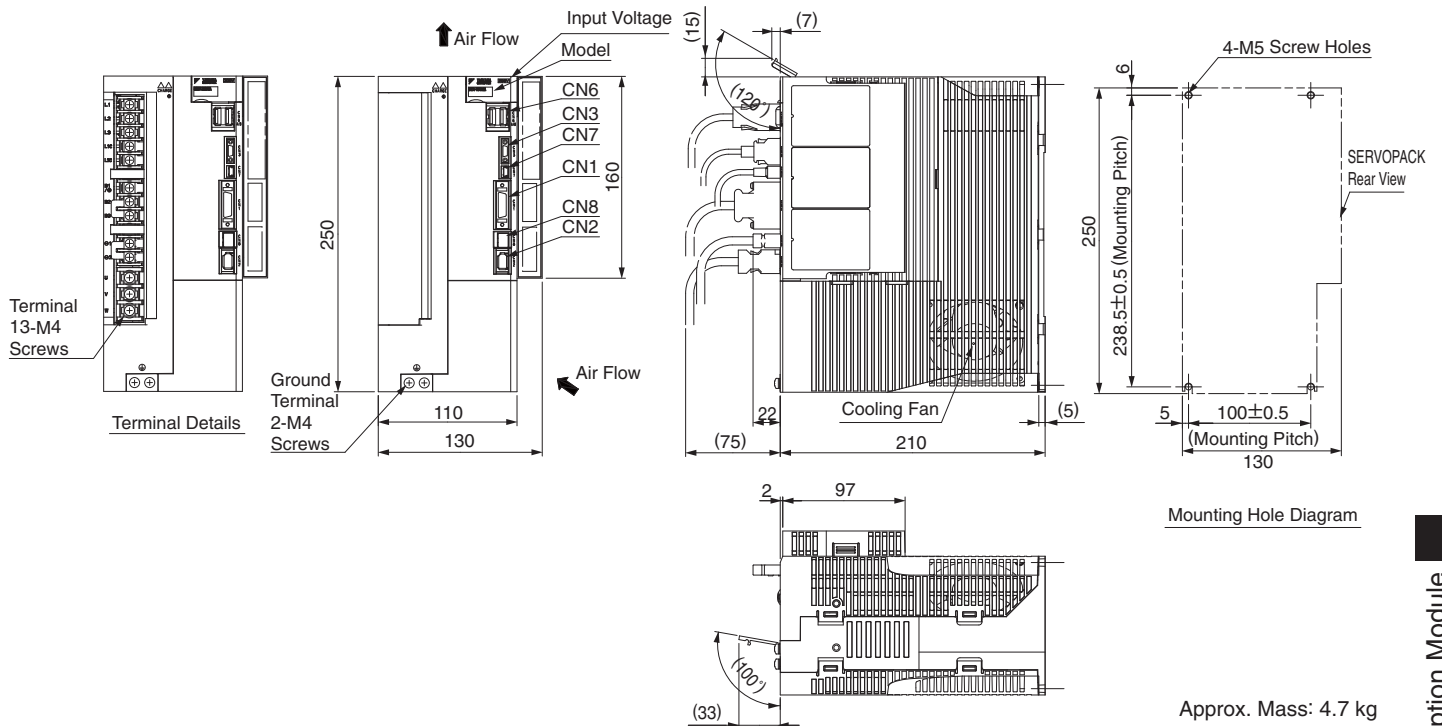

Connectors for Base-mounted SERVOPACKs

Port	Model	Pin	Manufacturer
CN1	10226-52A2PL	26	Sumitomo 3M Ltd.
CN2	53984-0671	6	Molex Japan Co., Ltd.
CN3	HDR-EC14LFDN-SLE-PLUS	14	Honda Tsushin Kogyo Co., Ltd.
CN6	1903815-1	8	Tyco Electronics AMP K.K.
CN7	MNC23-5K5H00	5	ADVANCED-CONNECTEK INC.
CN8	1981080-1	8	Tyco Electronics AMP K.K.

Note: The connectors above or their equivalents are used for SERVOPACKs.

External Dimensions Units: mm (for MECHATROLINK-II Communications Reference Type SERVOPACKs)

● **Rack-mounted SERVOPACKs**

(1) Single-phase 100 VAC, Model: SGDVR70F1 □ A001000001, SGDVR90F1 □ A001000001, and SGDV2R1F1 □ A001000001

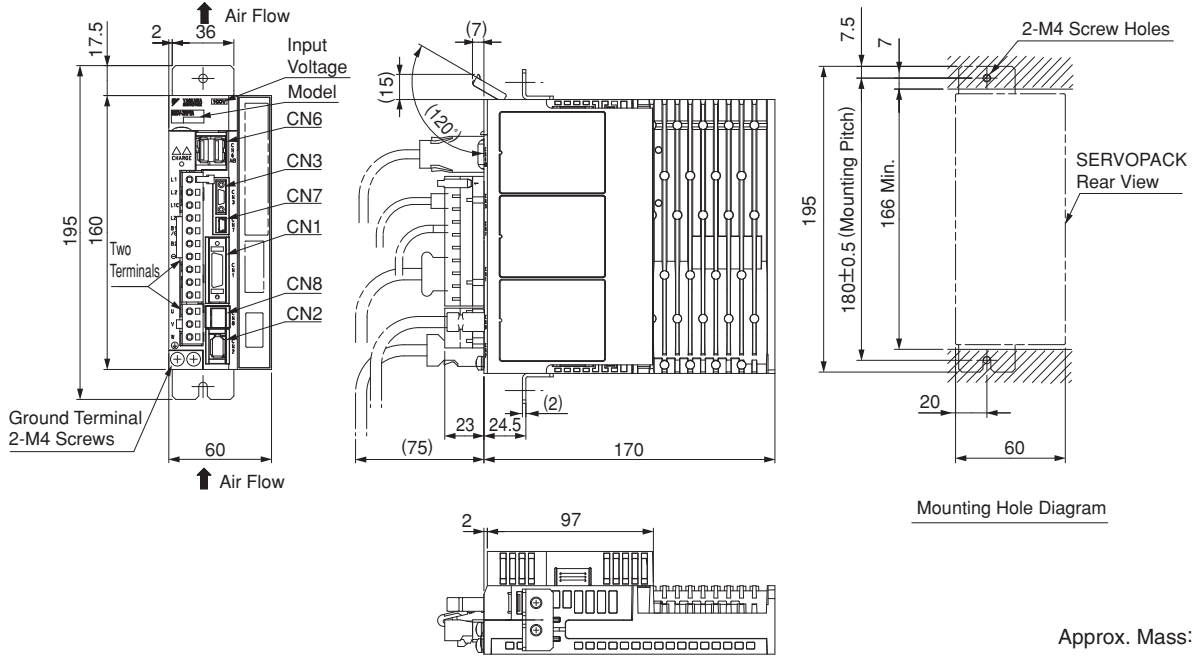

Approx. Mass: 1.1 kg

(2) Single-phase 100 VAC, Model: SGDV2R8F1 □ A001000001

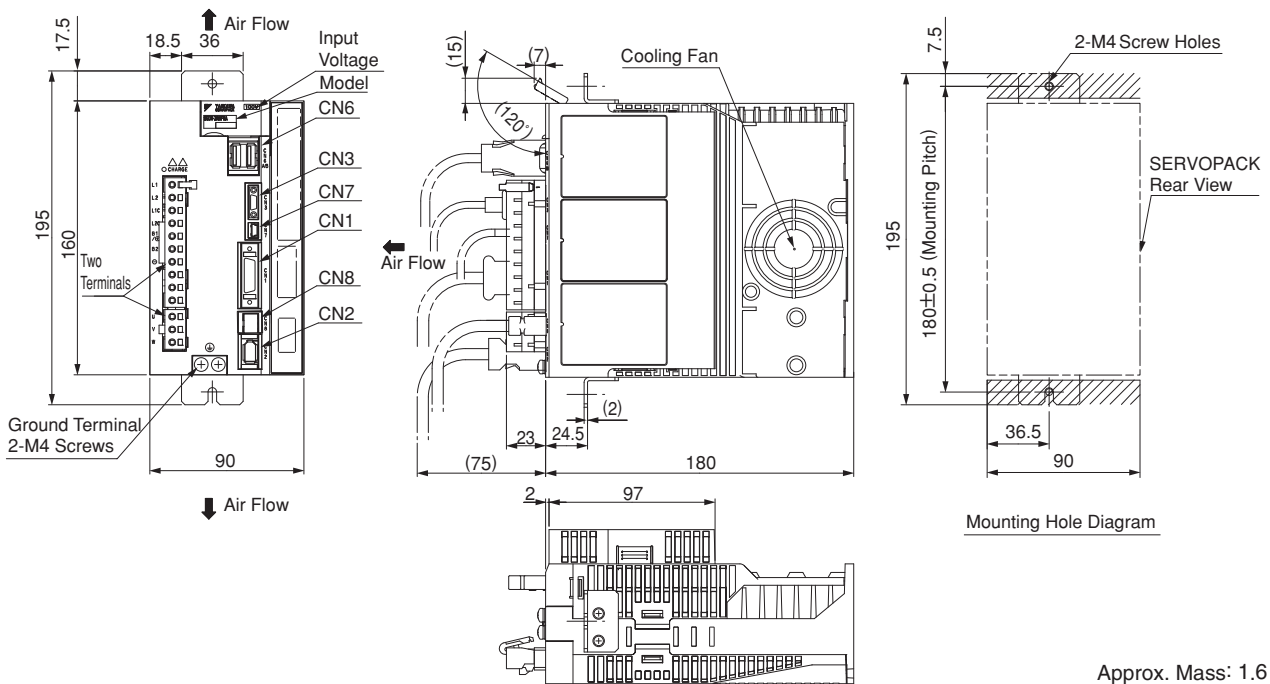

Approx. Mass: 1.6 kg

External Dimensions Units: mm (for MECHATROLINK-II Communications Reference Type SERVOPACKs)

(3) Three-phase 200 VAC, Model: SGDVR70A1□A001000001, SGDVR90A1□A001000001, and SGDVR6A1□A001000001

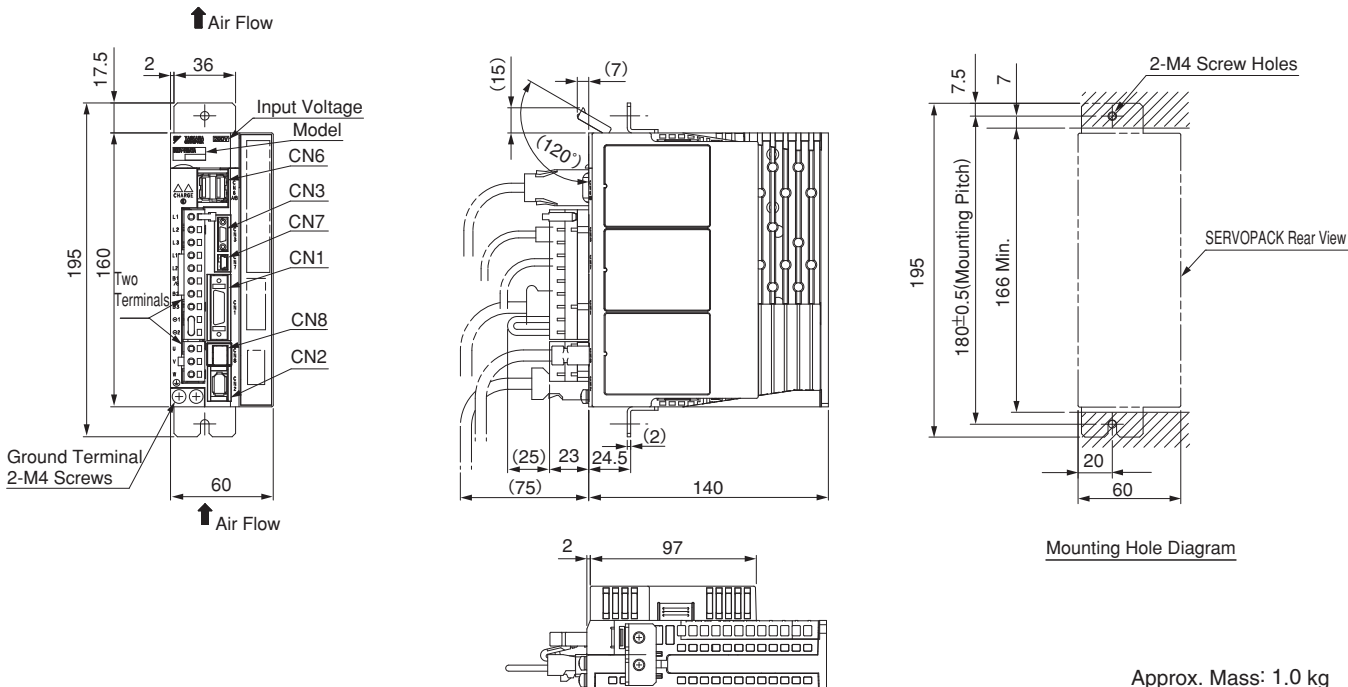

(4) Three-phase 200 VAC, Model: SGDV2R8A1□A001000001

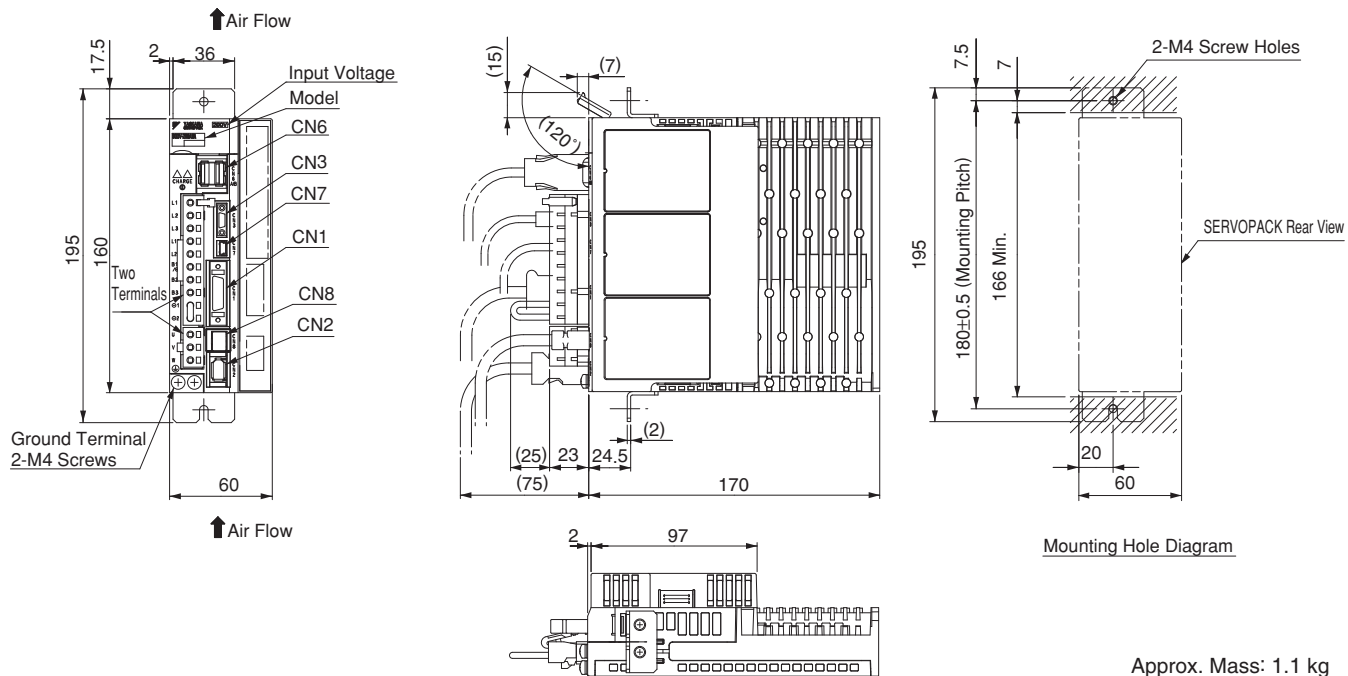

External Dimensions Units: mm (for MECHATROLINK-II Communications Reference Type SERVOPACKs)

(5) Three-phase 200 VAC, Model: SGDV3R8A1□A001000001, SGDV5R5A1□A001000001, and SGDV7R6A1□A001000001

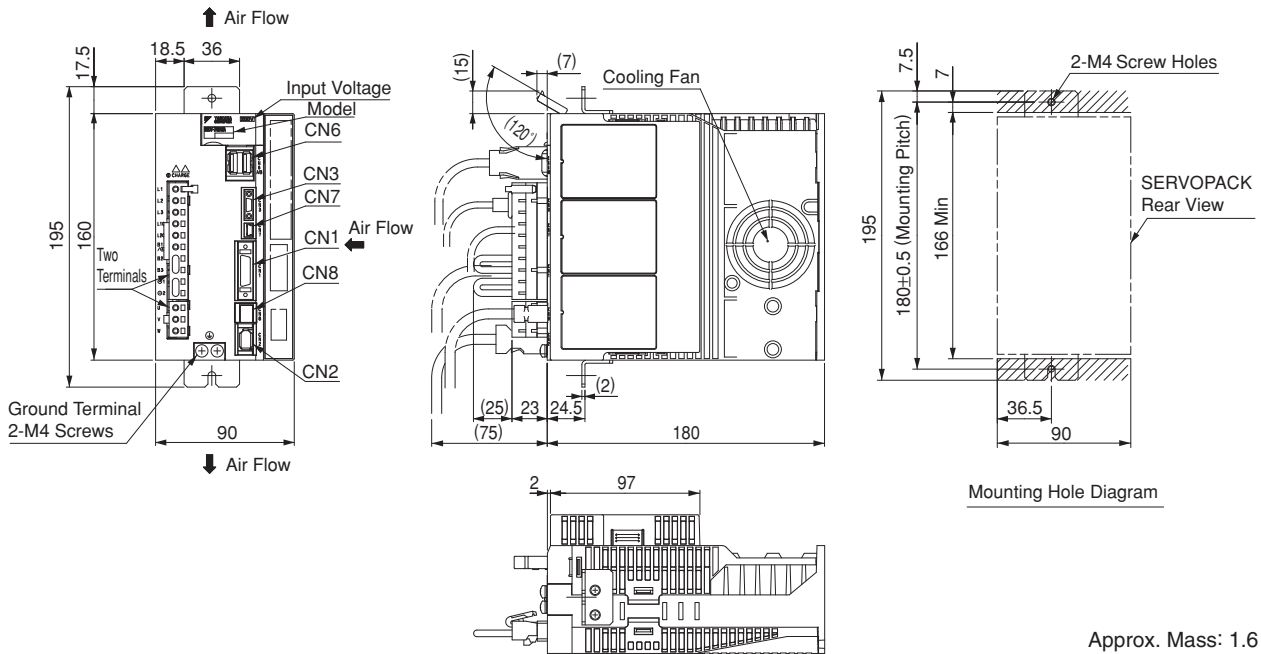

(6) Three-phase 200 VAC, Model: SGDV120A1□A001000001

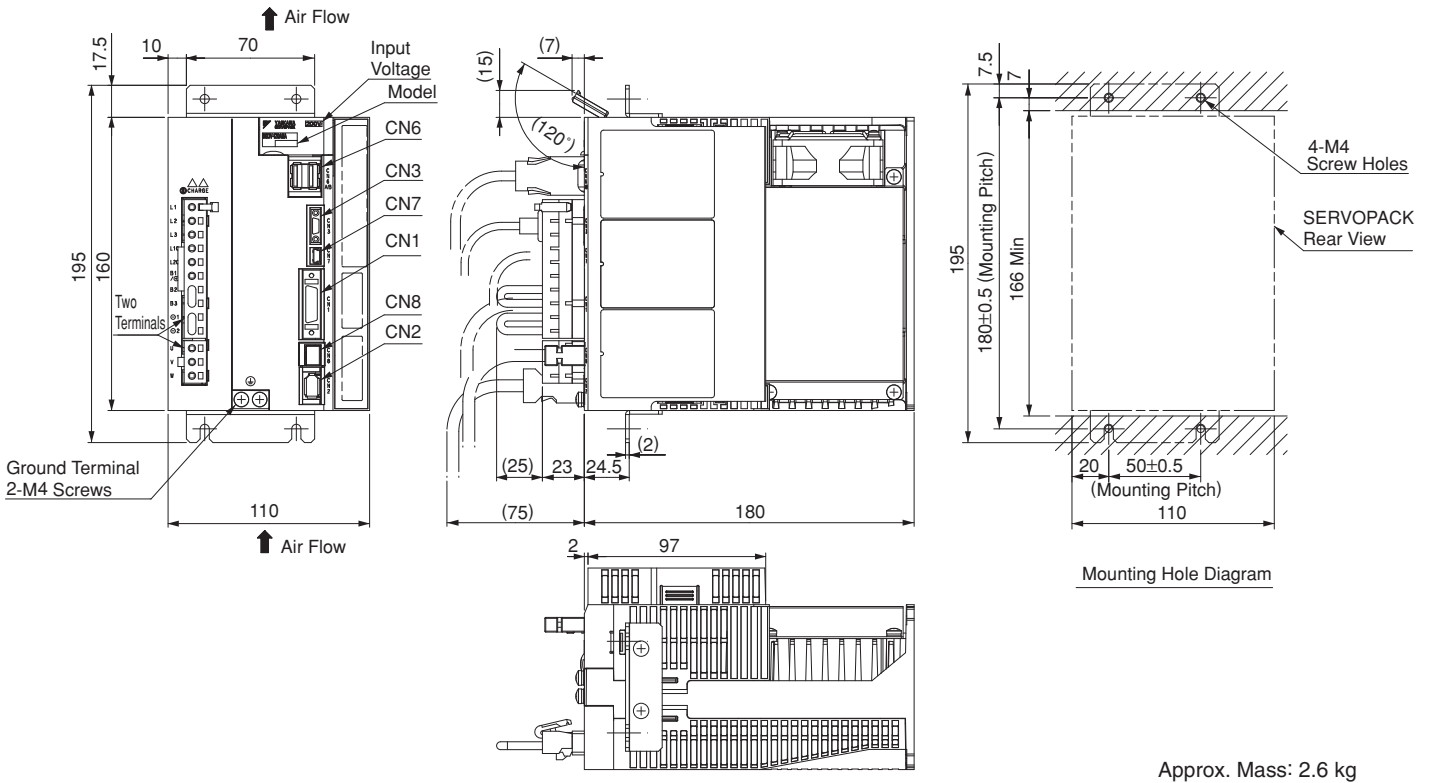

External Dimensions Units: mm (for MECHATROLINK-II Communications Reference Type SERVOPACKs)

(7) Three-phase 200 VAC, Model: SGDV180A1□A001000001, and SGDV200A1□A001000001

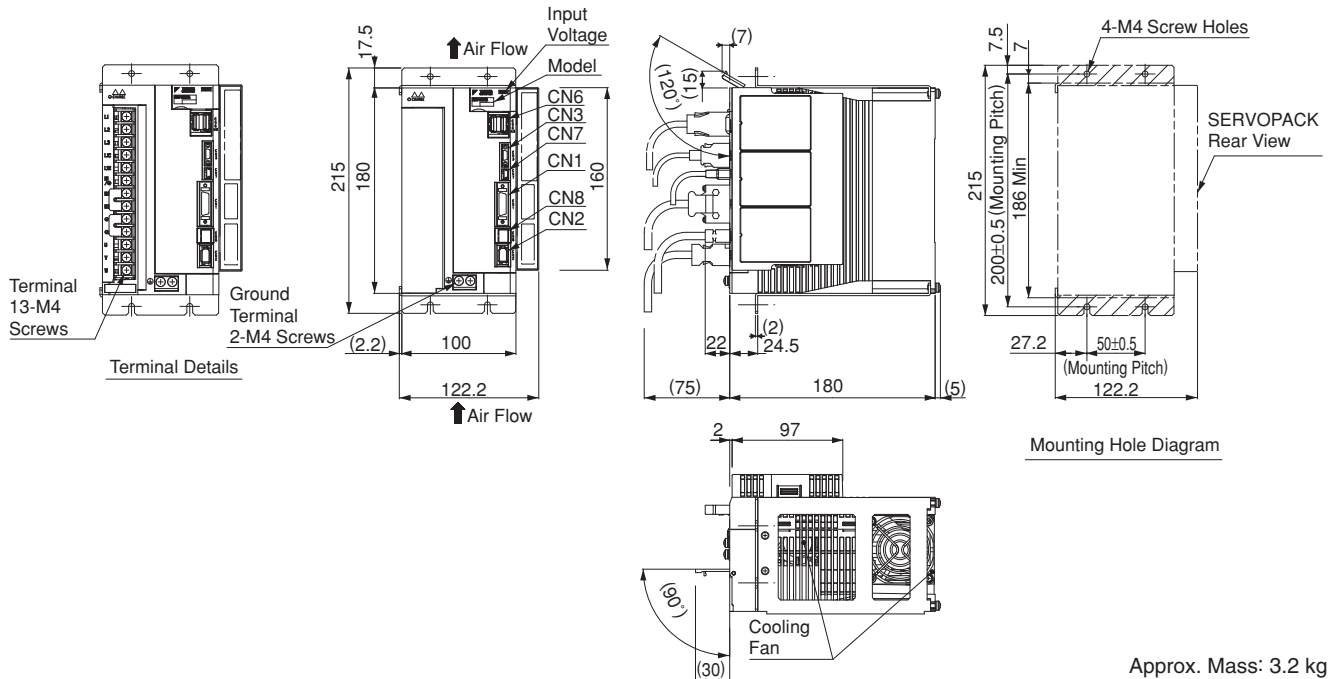

(8) Three-phase 200 VAC, Model: SGDV330A1□A001000001

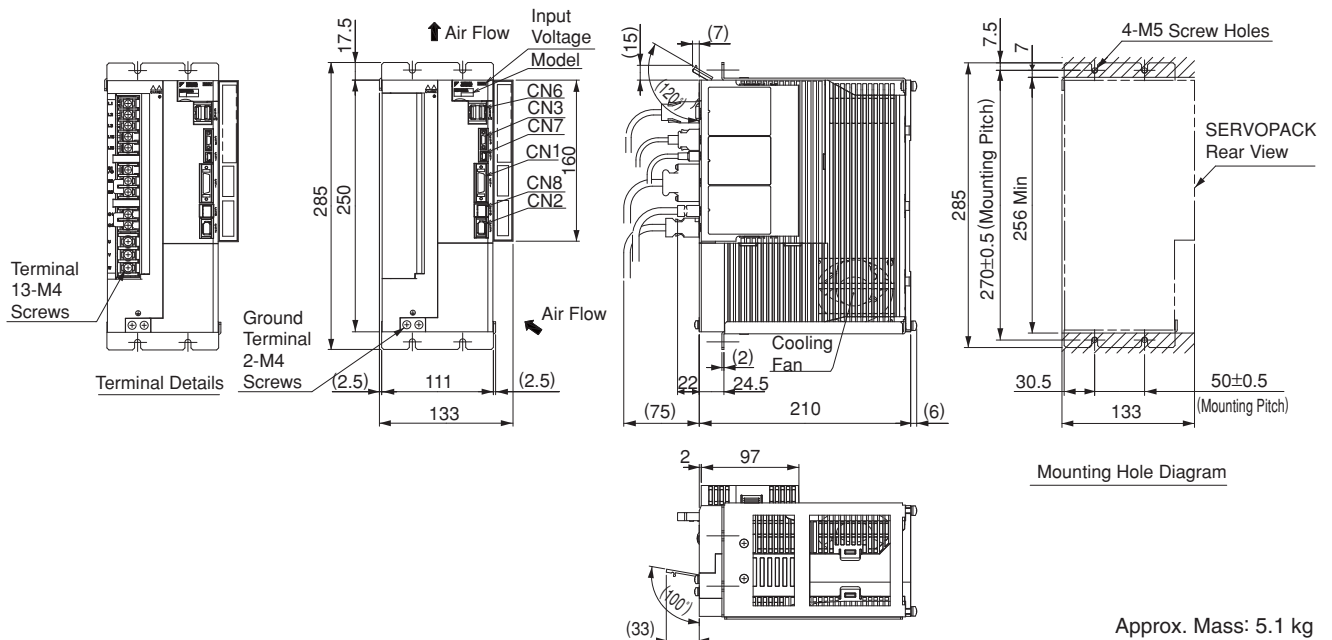

Connectors for Rack-mounted SERVOPACKs

Port	Model	Pin	Manufacturer
CN1	10226-52A2PL	26	Sumitomo 3M Ltd.
CN2	53984-0671	6	Molex Japan Co., Ltd.
CN3	HDR-EC14LFDN-SLE-PLUS	14	Honda Tsushin Kogyo Co., Ltd.
CN6	1903815-1	8	Tyco Electronics AMP K.K.
CN7	MNC23-5K5H00	5	ADVANCED-CONNECTEK INC.
CN8	1981080-1	8	Tyco Electronics AMP K.K.

Note: The connectors above or their equivalents are used for SERVOPACKs.



Option Module for Fully-closed Loop Control

● System Configuration for Fully-closed Loop Control

When using rotary servomotors with fully-closed loop control, use SERVOPACKs with option module for fully-closed loop control.

SERVOPACK with Option Module for Fully-closed Loop Control

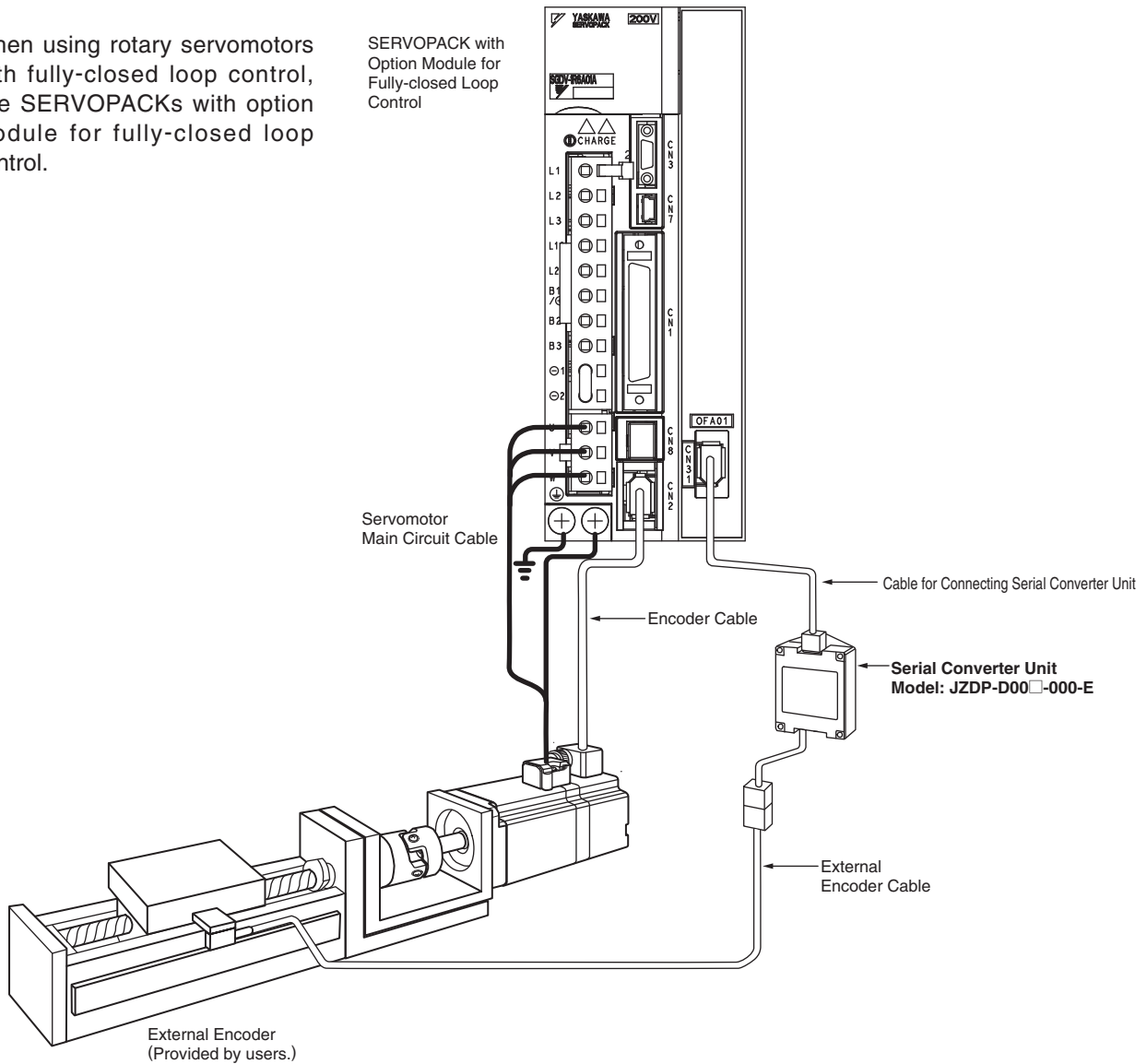

● Model Designations

JZDP - D00□ - 000 - E

Serial Converter Unit Model			
Code	Appearance	Applicable External Encoder	Hall Sensor
D003		Manufactured by HEIDENHAIN Corporation	None
D005		Manufactured by Renishaw plc.	None

Note: Using the serial converter unit JZDP-A□□□ with SGD-V SERVOPACK will void our guarantee.

Option Module for Fully-closed Loop Control

● External Dimensions Units: mm

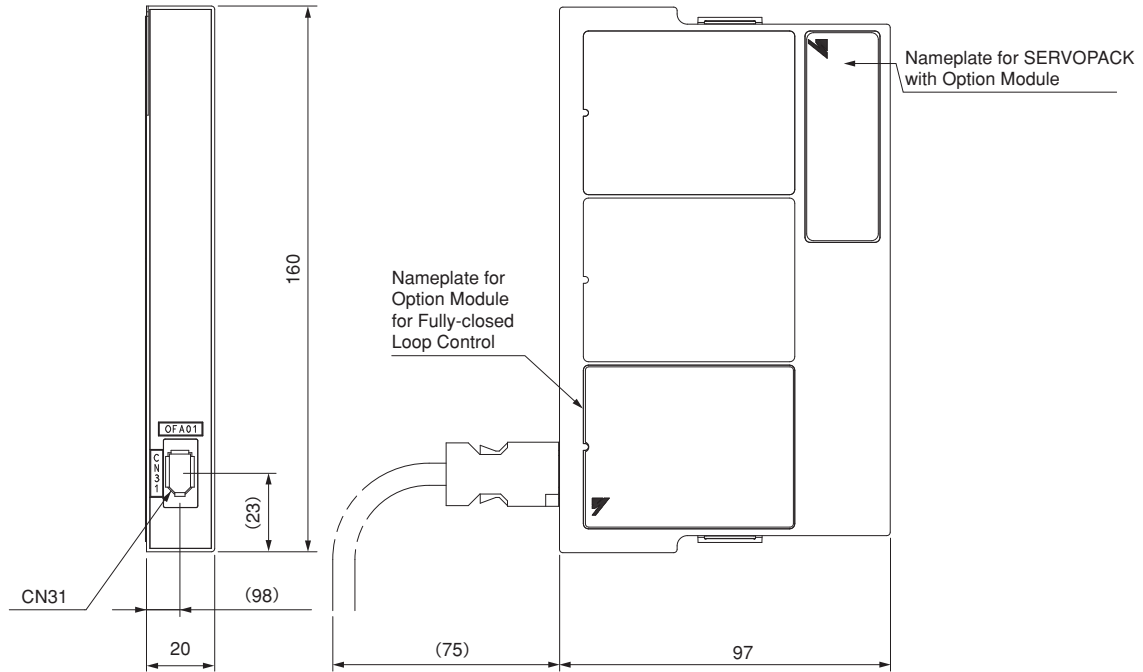

Approx. Mass: 0.1 kg

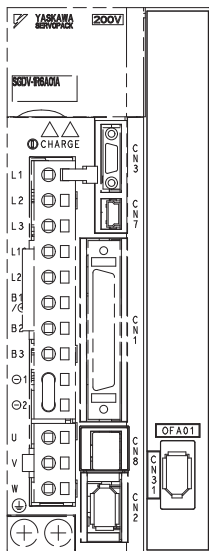

Connector

Port	Model	Pin	Manufacturer
CN31	53984-0671	6	Molex Japan Co., Ltd.

Note: The connectors above or their equivalents are used for SERVOPACKs.

Front View (mounted on analog and pulse train type SERVOPACK)

Serial Converter Units

● Characteristics and Specifications

Items		JZDP-D00□-000-E
Electrical Characteristics	Power Supply Voltage	+5.0 V ± 5%, ripple content 5% max.
	Current Consumption*1	120 mA typ. 350 mA max.
	Signal Resolution	Input two-phase sine wave: 1/256 pitch
	Max. Response Frequency	250 kHz
	Analog Input Signals*2 (cos, sin, Ref)	Differential input amplitude: 0.4 to 1.2 V Input signal level: 1.5 to 3.5 V
	Output Signal*3	Position data, alarms
	Output Method	Serial data communications
	Output Circuit	Balanced type transceiver (SN75LBC176 or the equivalent), internal terminating resistor: 120 Ω
Mechanical Characteristics	Approx. Mass	150 g
	Vibration Resistance	98 m/s ² max. (10 to 2500 Hz) in three directions
	Impact Resistance	980 m/s ² , (11 ms) two times in three directions
Environmental Conditions	Surrounding Air Temperature	0 to 55°C
	Storage Temperature	-20 to +80°C
	Humidity	20% to 90%RH (no condensation)

*1: The current consumption of the linear scale and hall sensor is not included in this value.

The current consumption of linear scale and hall sensor must be taken into consideration for the current capacity of host controller that supplies the power.
The current consumption of hall sensor: Approx. 40 mA.

*2: Input a value within the specified range. Otherwise, incorrect position information is output, and the device may be damaged.

*3: The transmission is enabled 100 to 300 ms after the power turns on.

● Analog Signal Input Timing

The following figure shows the input timing of the analog signals.

When the cos and sin signals are shifted 180 degrees, the differential signals are the /cos and /sin signals.

The specifications of the cos, /cos, sin, and /sin signals are identical except for the phase.

Input the signals Ref and /Ref so that they shall cross each other as shown in the figure because they are input into the converter. When they are crossed, the output data will be counted up.

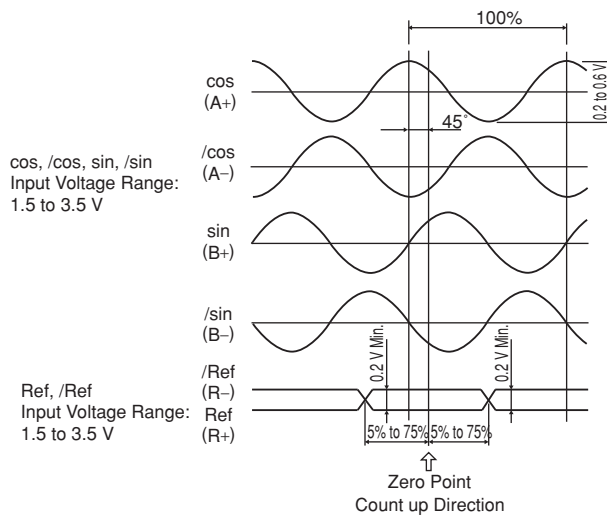

IMPORTANT

■ Precautions

- 1 Never perform insulation resistance and withstand voltage tests.
- 2 When analog signals are input to the serial converter unit, noise influence on the analog signals affects the unit's ability to output correct position information. The analog cable must be as short as possible and shielded.
- 3 Do not connect or disconnect the unit while power is being supplied, or the unit may be damaged.
- 4 When using multiple axes, use a shield cable for each axis. Do not use a shield cable for multiple axes.

Serial Converter Units Units: mm

● External Dimensions

(1) Model: JZDP-D003-000-E

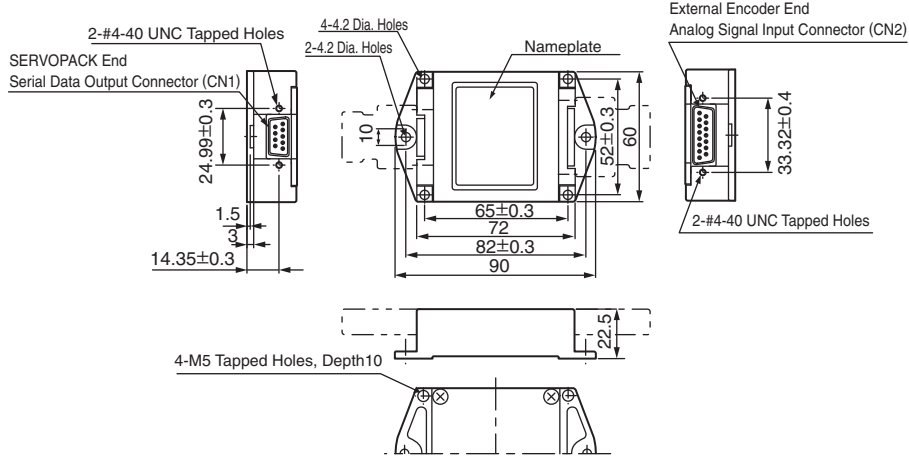

(2) Model: JZDP-D005-000-E

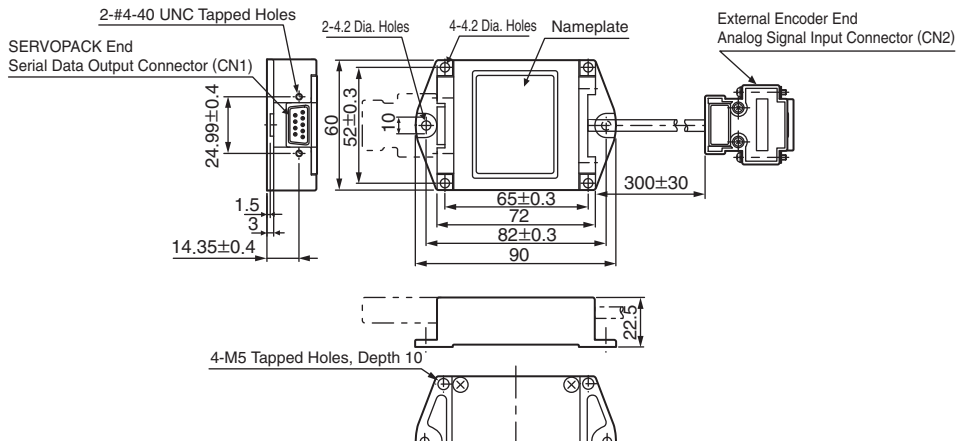

● Connection Cables

· Recommended Cables

Name	Application	Model	Length
Cable for Connecting Serial Converter Unit	Connection between SERVOPACK (Option module for fully-closed loop control) connector CN31 and serial converter unit	JZSP-CLP70-03-E	3 m
		JZSP-CLP70-05-E	5 m
		JZSP-CLP70-10-E	10 m
		JZSP-CLP70-15-E	15 m
		JZSP-CLP70-20-E	20 m

· Dimensional Drawing

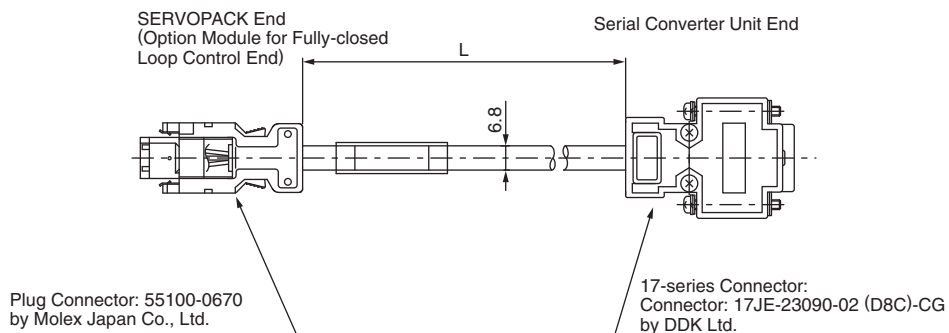

Serial Converter Units

● Connection Examples

(1) Connection Example with External Encoder by HEIDENHAIN Corporation

• Model: JZDP-D003-000-E

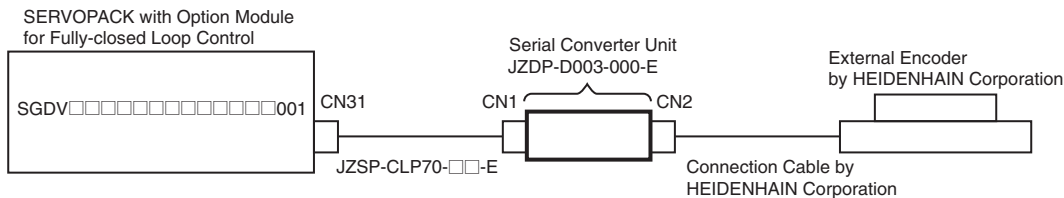

Pin No.	Signal
1	+5V
2	Phase S output
3	Not used
4	Not used
5	0V
6	Phase /S output
7	Not used
8	Not used
9	Not used
Case	Shield

CN1
SERVOPACK End
Serial Data Output

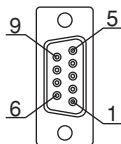

17-series Connector:
17LE-13090-27-FA
(Socket) by DDK Ltd.

Pin No.	Signal
1	cos input (A+)
2	0V
3	sin input (B+)
4	+5V
5	Not used
6	Not used
7	/Ref input (R-)
8	Not used
9	/cos input (A-)
10	0V sensor
11	/sin input (B-)
12	5V sensor
13	Not used
14	Ref input (R+)
15	Not used
Case	Shield

CN2
External Encoder End
Analog Signal Input

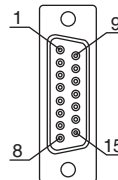

17-series Connector:
17LE-13150-27-FA
(Socket) by DDK Ltd.

Notes: 1 Do not use the unused pins.

2 The external encoder (analog 1 Vp-p output, D-sub 15-pin) by HEIDENHAIN Corporation can be directly connected.

(2) Connection Example with External Encoder by Renishaw plc.

• Model : JZDP-D005-000-E

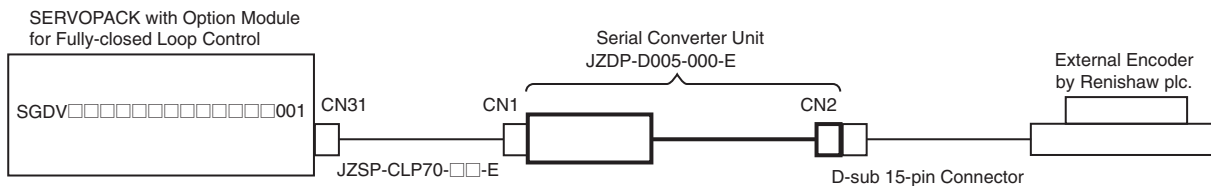

Pin No.	Signal
1	+5V
2	Phase S output
3	Not used
4	Not used
5	0V
6	Phase /S output
7	Not used
8	Not used
9	Not used
Case	Shield

CN1
SERVOPACK End
Serial Data Output

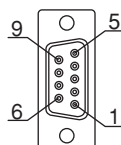

17-series Connector:
17LE-13090-27-FA
(Socket) by DDK Ltd.

Pin No.	Signal
1	/cos input (V1-)
2	/sin input (V2-)
3	Ref input (V0+)
4	+5V
5	5Vs
6	Not used
7	Not used
8	Not used
9	cos input (V1+)
10	sin input (V2+)
11	/Ref input (V0-)
12	0V
13	0Vs
14	Not used
15	Inner (0V)
Case	Shield

CN2
External Encoder End
Analog Signal Input

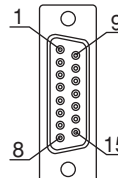

17-series Connector:
17JE-13150-02 (D8C) A-CG
(Socket) by DDK Ltd.

SERVOPACK does not have the function to process Vq signals.

Notes: 1 Do not use the unused pins.

2 The external encoder (analog 1 Vp-p output, D-sub 15-pin) by Renishaw plc. can be directly connected. However, the BID and DIR signals are not connected.

3 Use the external encoder-end connector to change the home position specifications of the external encoder.

Serial Converter Units

(3) Connection Example with External Encoder by Mitutoyo Corporation (Model: ABS ST78□A)
When using this external encoders, serial converter units are not required.

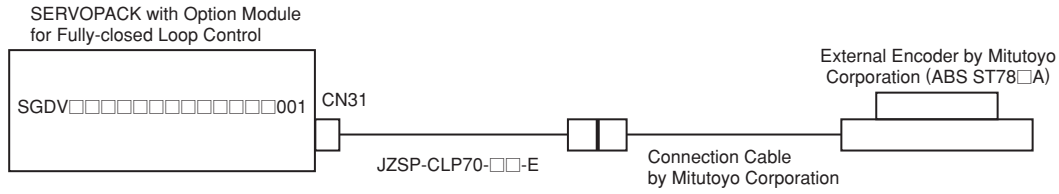



Wiring Main Circuit and Peripheral Devices

Wiring Main Circuit

● Typical Main Circuit Wiring Examples

This section describes the typical main circuit wiring examples.

⚠ WARNING

After turning OFF the power, do not touch the power terminals while charge indicator is still ON. High residual voltage may still remain in the SERVOPACK. When the voltage is discharged, the charge indicator will turn OFF. Make sure the charge indicator is OFF before starting wiring or inspection.

● Single-phase 100 V

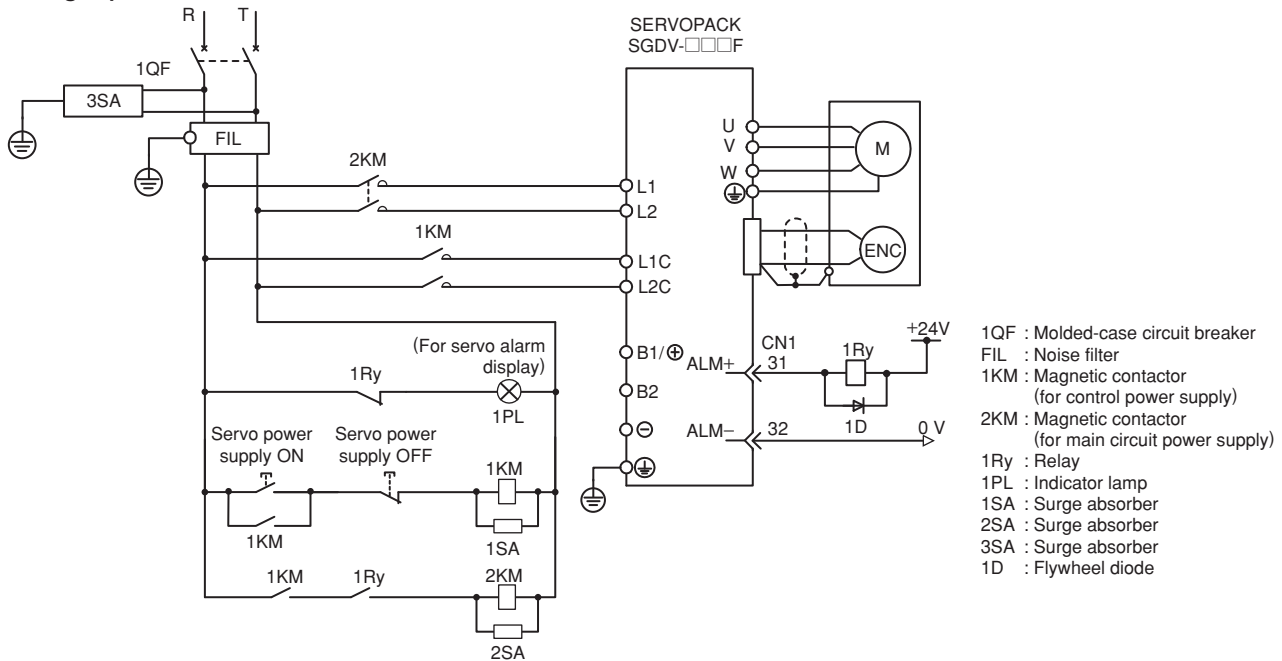

● Three-phase 200 V

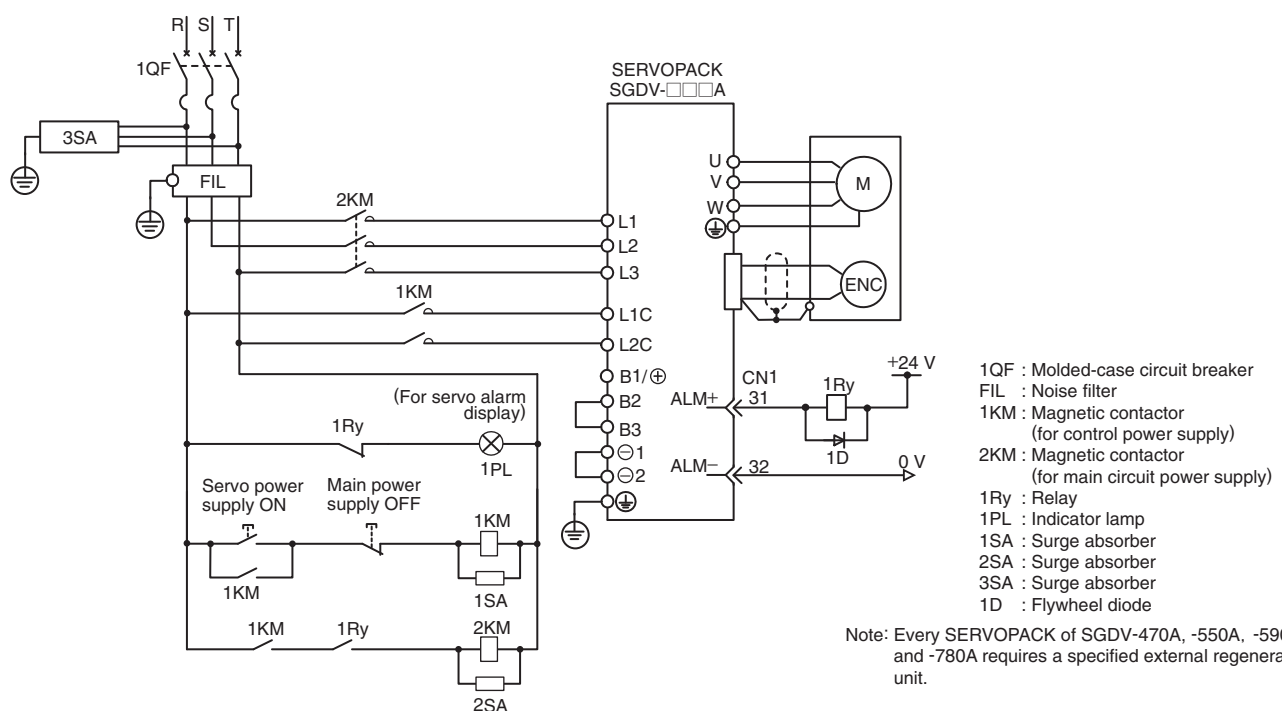

Wiring Main Circuit

● Three-phase 400 V

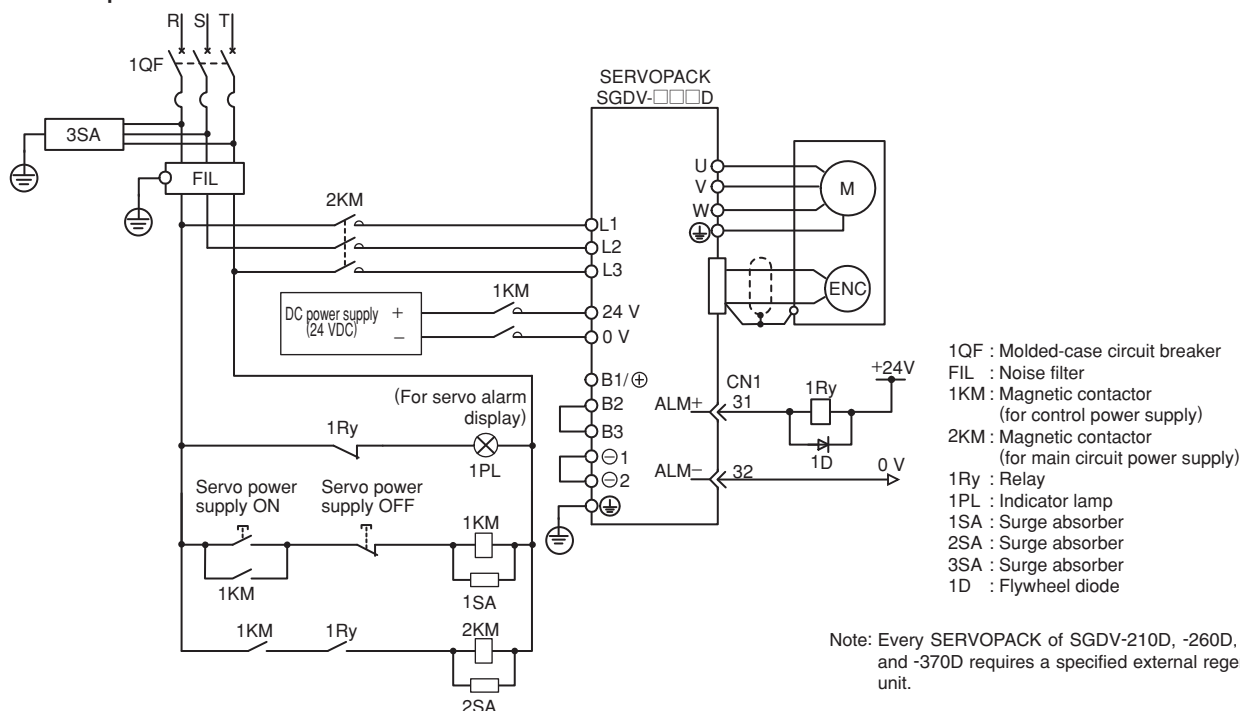

● General Precautions for Wiring

IMPORTANT

- Use a molded-case circuit breaker (QF) or fuse to protect the Main Circuit.
 The SERVOPACK connects directly to a commercial power supply; it is not isolated by a transformer or other device.
 Always use a molded-case circuit breaker (QF) or fuse to protect the servo system from accidents involving different power system voltages or other accidents.
- Install a ground fault detector.
 The SERVOPACK does not have a built-in protective circuit for grounding. To configure a safer system, install a ground fault detector against overloads and short-circuiting, or install a ground fault detector combined with a molded-case circuit breaker.
- Do not turn power ON and OFF frequently.
 The power supply in the SERVOPACK contains a capacitor, which causes a high charging current to flow when power is turned ON. Frequently turning power ON and OFF will cause the main circuit elements in the SERVOPACK to deteriorate.

To ensure safe, stable application of the servo system, observe the following precautions when wiring.

Observe the following precautions when wiring the main circuit.

- Use shielded twisted-pair wires or shielded multi-core twisted-pair wires for signal lines and encoder lines.
- The maximum wiring length is 3 m for signal lines and 50 m for encoder lines.

Observe the following precautions when wiring the ground.

- Use a cable as thick as possible (at least 2.0 mm²)
- Ground the 100-V and the 200-V SERVOPACK to a resistance of 100 Ω or less. Ground the 400-V SERVOPACK to a resistance of 10 Ω or less.
- Be sure to ground at only one point.
- Ground the servomotor directly if the servomotor is insulated from the machine.

The signal cable conductors are as thin as 0.2 mm² or 0.3 mm². Do not impose excessive bending force or tension.

● Precautions When Using the SERVOPACK with a DC Power Input

When using the SERVOPACK with a DC power input, refer to 3.1.5 Precautions When using the SERVOPACK with a DC power input on "AC Servo Drives Σ -V Series USER'S MANUAL Design and Maintenance." (manual no. SIEP S800000 45)

Wiring Main Circuit

●Precautions When Using More Than One SERVOPACK

This section shows an example of the wiring when more than one SERVOPACK is used and the precautions.

●Wiring Example

Connect the alarm output (ALM) terminals for the three SERVOPACKs in series to enable alarm detection relay 1RY to operate. When a SERVOPACK alarm is activated, the ALM output signal transistor is turned OFF.

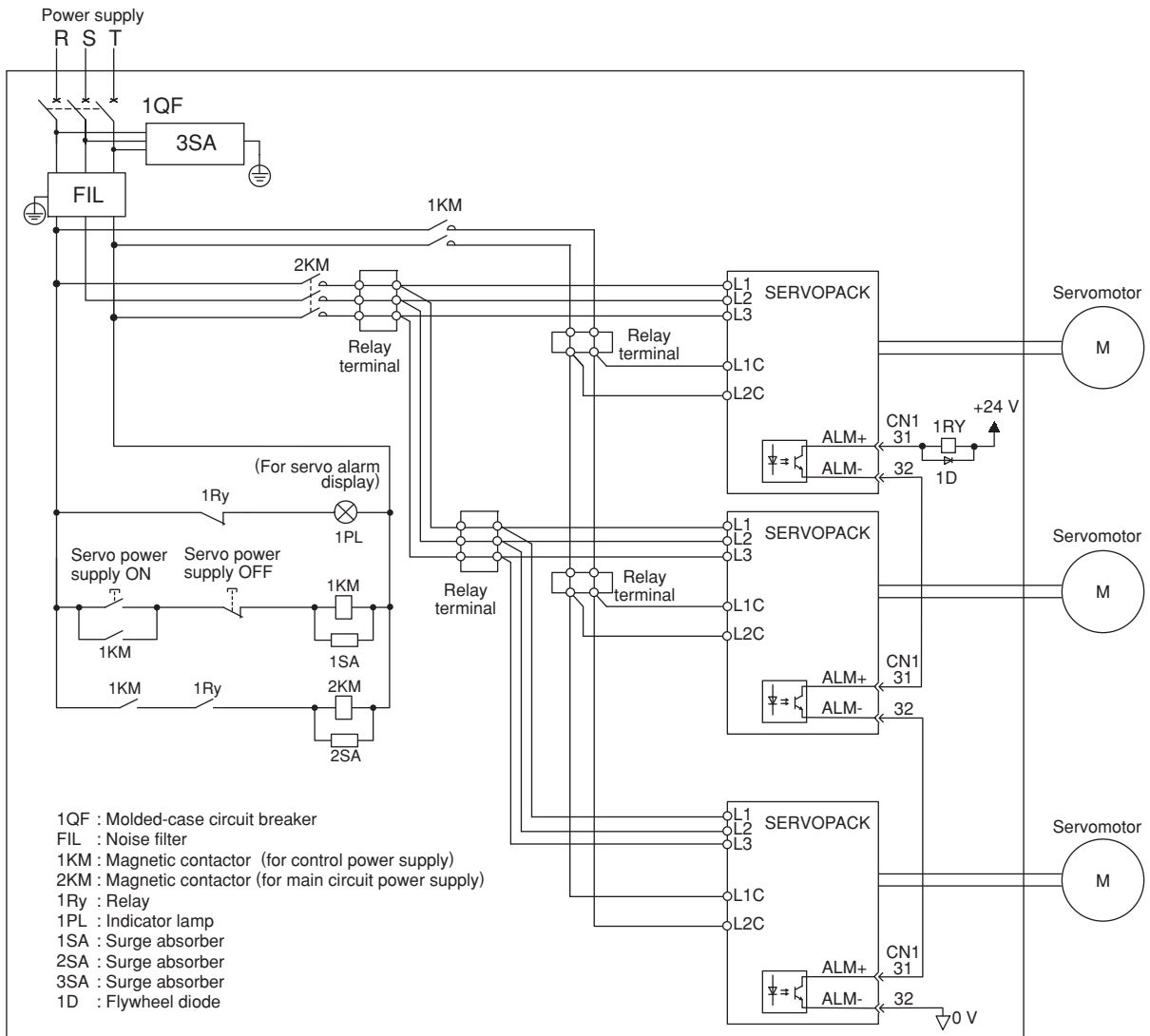

●Precautions

Multiple servos can share a single molded-case circuit breaker (QF) or noise filter. Always select a QF or noise filter that has enough capacity for the total power capacity (load conditions) of those servos.

SERVOPACK Main Circuit Wire

● Single-phase, 100 V

Cables	Terminal Symbol	SERVOPACK Model SGD V-			
		R70F	R90F	2R1F	2R8F
Main Circuit Power Cable	L1, L2	HIV1.25		HIV2.0	
Servomotor Main Circuit Cable	U, V, W	HIV1.25			
Control Power Cable	L1C, L2C	HIV1.25			
External Regenerative Resistor Cable	B1/⊕, B2	HIV1.25			
Ground Cable	⊖	HIV2.0 min.			

● Three-phase, 200 V

Cables	Terminal Symbol	SERVOPACK Model SGD V-														
		R70A	R90A	1R6A	2R8A	3R8A	5R5A	7R6A	120A	180A	200A	330A	470A	550A	590A	780A
Main Circuit Power Cable	L1, L2, L3	HIV1.25			HIV2.0				HIV3.5		HIV5.5	HIV8	HIV14	HIV22		
Servomotor Main Circuit Cable	U, V, W	HIV1.25			HIV2.0				HIV3.5	HIV5.5	HIV8.0	HIV14		HIV22		
Control Power Cable	L1C, L2C	HIV1.25														
External Regenerative Resistor Cable	B1/⊕, B2	HIV1.25						HIV2.0	HIV3.5	HIV5.5	HIV8		HIV22			
Ground Cable	⊖	HIV2.0 min.														

● Three-phase, 400 V

Cables	Terminal Symbol	SERVOPACK Model SGD V-										
		1R9D	3R5D	5R4D	8R4D	120D	170D	210D	260D	280D	370D	
Main Circuit Power Cable	L1, L2, L3	HIV1.25			HIV2.0		HIV3.5		HIV5.5	HIV8	HIV14	
Servomotor Main Circuit Cable	U, V, W	HIV1.25			HIV2.0		HIV3.5	HIV5.5		HIV8	HIV14	
Control Power Cable	24V, 0V	HIV1.25										
External Regenerative Resistor Cable	B1/⊕, B2	HIV1.25					HIV2.0	HIV3.5		HIV5.5	HIV8	
Ground Cable	⊖	HIV2.0 min.										

● Wire Type

Wire Type		Allowable Conductor Temperature °C
Code	Name	
PVC	Polyvinyl chloride insulated wire	—
IV	600 V polyvinyl chloride insulated wire	60
HIV	600 V grade heat-resistant polyvinyl chloride insulated wire	75

SERVOPACK Main Circuit Wire

The following table shows the size and allowable currents for the wires. Use a wire whose specifications meet or are less than the values in the table.

• 600 V grade heat-resistant polyvinyl chloride insulated wires

Nominal Cross Section Diameter mm ²	AWG size	Allowable Current at Ambient Temperatures A		
		30°C	40°C	50°C
0.5	20	6.6	5.6	4.5
0.75	–	8.8	7	5.5
0.9	18	9	7.7	6
1.25	17 to 16	12	11	8.5
2.0	14	23	20	16
3.5	12 to 11	33	29	24
5.5	10 to 9	43	38	31
8.0	8	55	49	40
14.0	6 to 5	79	70	57
22.0	4 to 3	91	81	66

Note: The values in the table are only for reference.

IMPORTANT

- 1 Wire sizes are selected for three cables per bundle at 40°C ambient temperature with the rated current.
- 2 Use a wire with a minimum withstand voltage of 600 V for the main circuit.
- 3 If wires are bundled in PVC or metal ducts, take into account the reduction of the allowable current.
- 4 Use a heat-resistant wire under high ambient or panel temperatures, where polyvinyl chloride insulated wires will rapidly deteriorate.

Molded-case Circuit Breaker and Fuse Capacity

Main Circuit Power Supply	Applicable Servomotor Max. Capacity kW	SERVOPACK Model SGD V-	Power Supply Capacity per SERVOPACK kVA	Current Capacity		Inrush Current	
				Main Circuit Arms	Control Circuit Arms	Main Circuit A0-p	Control Circuit A0-p
Single-phase 100 V	0.05	R70F	0.2	1.5	0.38	16.5	35
	0.1	R90F	0.3	2.5			
	0.2	2R1F	0.7	5			
	0.4	2R8F	1.4	10			
Three-phase 200 V	0.05	R70A	0.2	1.0	0.2	33	70
	0.1	R90A	0.3	1.0			
	0.2	1R6A	0.6	2.0			
	0.4	2R8A	1	3.0			
	0.5	3R8A	1.4	3.0			
	0.75	5R5A	1.6	6.0			
	1.0	7R6A	2.3	6.0	0.25	33	33
	1.5	120A	3.2	7.3			
	2.0	180A	4	9.7			
	3.0	200A	5.9	15			
	5.0	330A	7.5	25			
	6.0	470A	10.7	29			
	7.5	550A	14.6	37			
	11	590A	21.7	54			
15	780A	29.6	73				
Three-phase 400 V	0.5	1R9D	1.1	1.4	1.2	17	-
	1.0	3R5D	2.3	2.9			
	1.5	5R4D	3.5	4.3			
	2.0	8R4D	4.5	5.8	1.4	34	
	3.0	120D	7.1	8.6			
	5.0	170D	11.7	14.5			
	6.0	210D	12.4	17.4			
	7.5	260D	14.4	21.7	1.5	34	
	11	280D	21.9	31.8			
	15	370D	30.6	43.4	1.7	68	

Notes: 1 To comply with the low voltage directive, connect a fuse to the input side. Select the fuse or molded-case circuit breaker for the input side from among models that are compliant with UL standards.

The table above also provides the net values of current capacity and inrush current. Select a fuse and a molded-case circuit breaker which meet the breaking characteristics shown below.

- Main circuit, control circuit: No breaking at three-times the current values of the table for 5 s.
- Inrush current: No breaking at the same current values of the table for 20 ms.

2 In accordance with UL standards, the following restrictions apply.

SERVOPACK SGD V-	Restrictions
180A, 200A	Available rated current for molded-case circuit breaker: 40 A or less
330A	<ul style="list-style-type: none"> · Available rated current for non-time delay fuse: 70 A or less · Available rated current for time delay fuse: 40 A or less · Do not use single wires.
470A, 550A	<ul style="list-style-type: none"> · Available rated current for molded-case circuit breaker: 60 A or less · Available rated current for non-time delay fuse or time delay fuse: 60 A or less
590A, 780A	<ul style="list-style-type: none"> · Available rated current for molded-case circuit breaker: 100 A or less · Available rated current for non-time delay fuse or time delay fuse: 100 A or less (Available rated current for class J non-time delay or faster fuse: 125 A or less)
210D, 260D	<ul style="list-style-type: none"> · Available rated current for molded-case circuit breaker: 60 A or less · Available rated current for non-time delay fuse: 60 A or less · Available rated current for time delay fuse: 35 A or less
280D, 370D	<ul style="list-style-type: none"> · Available rated current for molded-case circuit breaker: 80 A or less · Available rated current for non-time delay fuse: 125 A or less · Available rated current for time delay fuse: 75 A or less

Noise Filters

● Noise Filter Selection

Main Circuit Power Supply	SERVOPACK Model SGD V-	Recommended Noise Filter			Details
		Model	Specifications	Leakage Current	
Single-phase 100 V	R70F,R90F	FN2070-6/07	Single-phase 250V 6A	0.734 mA 230VAC/50Hz	(1)
	2R1F	FN2070-10/07	Single-phase 250V 10A		
	2R8F	FN2070-16/07	Single-phase 250V 16A		
Three-phase 200 V	R70A,R90A,1R6A 2R8A,3R8A	FN258L-7/07	Three-phase 480V 7A	0.5 mA 440VAC/50Hz	(2)
	5R5A,7R6A	FN258L-16/07	Three-phase 480V 16A	0.8 mA 440VAC/50Hz	
	120A,180A	HF3020C-UQC	Three-phase 480V 20A	10 mA 400VAC/50Hz	(3)
	200A	HF3030C-UQC	Three-phase 480V 30A		
	330A, 470A	HF3050C-UQC	Three-phase 480V 50A		
	550A	HF3060C-UQC	Three-phase 480V 60A		
	590A, 780A	HF3100C-UQB	Three-phase 480V 100A		
Three- phase 400 V	1R9D,3R5D,5R4D	FN258L-7/07	Three-phase 480V 7A	0.8 mA	(2)
	8R4D,120D	FN258L-16/07	Three-phase 480V 16A	440VAC/50Hz	(2)
	170D	FMAC-0934-5010	Three-phase 480V 35A	160 mA 440VAC/50Hz	(3)
	210D, 260D	HF3050C-UQC	Three-phase 480V 50A	10 mA	(2)
	280D, 370D	HF3080C-UQC	Three-phase 480V 80A	400VAC/50Hz	(3)

Note: RoHS-compliant models are not available. Contact the manufactures when in need of an RoHS-compliant model.

IMPORTANT

Some models of noise filters have high levels of the leakage current. Also, the leakage current varies greatly with the grounding environment. To select the best ground fault detectors for use, consider the grounding environment and the leakage current of the noise filter. For more details, contact the manufacturer of the noise filter.

Noise Filters

● External Dimensions (Units: mm)
 (1) FN Type (by Schaffner EMC, Inc.)

Model		FN2070-6/07	FN2070-10/07	FN2070-16/07
Dimensional Drawings				
External Dimensions	Code	Dimensions		
	A	113.5±1	156±1	119±0.5
	B	57.5±1		85.5±1
	C	45.4±1.2		57.6±1
	D	94±1	130.5±1	98.5±1
	F	103±0.3	143±0.3	109±0.3
	J	25±0.2		40±0.2
	K	8.4±0.5		8.6±0.5
	L	32.4±0.5		—
	M	4.4±0.1	5.3±0.1	4.4±0.1
	N	6±0.1		7.4±0.1
	P	0.9±0.1		1.2±0.1
	Q	—		66±0.3
R	—		51±0.2	
S	38±0.5		—	

Noise Filters

(2) FN Type and HF Type

Model	FN Type [by Schaffner EMC, Inc.]		HF Type [by SOSHIN ELECTRIC CO., LTD.]		
	FN258L-7/07	FN258L-16/07	HF3020C-UQC HF3030C-UQC	HF3050C-UQC HF3060C-UQC	
Dimensional Drawings					
External Dimensions mm	Code	Dimensions		Dimensions	
	A	255±1	305±1	236	256
	B	126±0.8	142±0.8	221	241
	C	50±0.6	55±0.6	206	226
	D	225±0.8	275±0.8	184	204
	E	240±0.5	290±0.5	105	115
	F	25±0.3	30±0.3	90	100
	G	6.5±0.2		76	86
	H	300±10		122	127
	J	1±0.1		5.5×7 Dia.	5.5×7 Dia.
	K	-		M5	M5
	L	9±1		M5	M5
	M	-		16	16
	N	-		13	13
O	M5		51.4	51.4	
P	AWG16	AWG14	13	13	
Q	-		61.1	61.1	

(3) HF Type and FMAC Type

Model	HF Type [by SOSHIN ELECTRIC CO., LTD.]	FMAC Type [by Schurter, Inc.]
	HF3080C-UQC HF3100C-UQB	FMAC-0934-5010
External Dimensions mm		

Surge Absorber

● Surge Absorber Selection

The surge absorber (for lightning surge) absorbs lightning surge and prevents faulty operation in or damage to electronic circuits.

Main Circuit Power Supply	SERVOPACK Model SGDV-	Recommended Surge Absorber
Single-phase 100 V	□□□F	LT-C12G801WS
Three-phase 200 V	□□□A	LT-C32G801WS
Three-phase 400 V	□□□D	LT-C35G102WS

● External Dimensions (Units: mm)

Model: LT-C32G801WS, LT-C35G102WS, LT-C12G801WS [by SOSHIN ELECTRIC CO., LTD.]

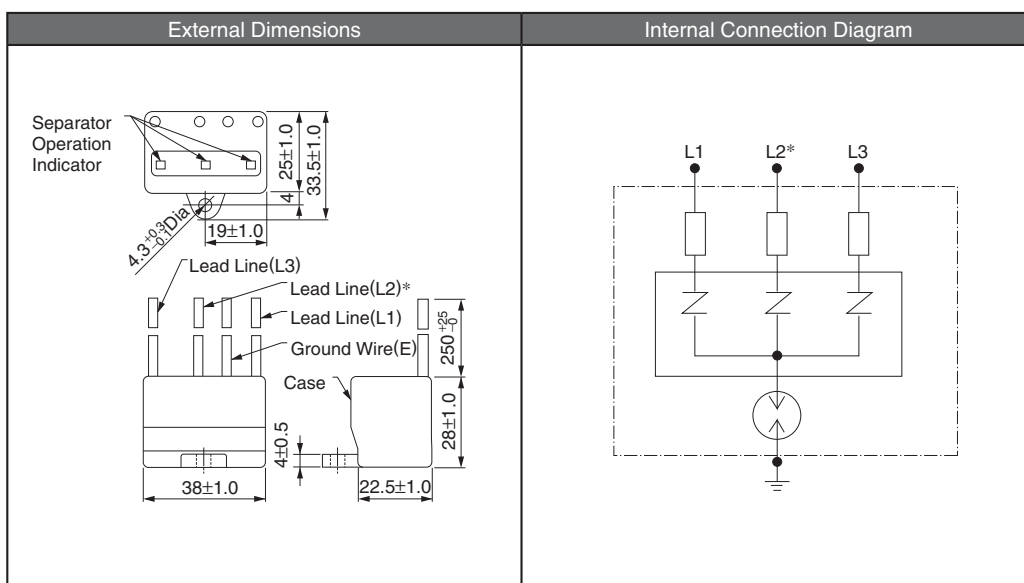

*: No L2 is on the LT-C12G801WS surge absorber.

Magnetic Contactors

●Magnetic Contactor Selection

A magnetic contactor is required to make the AC power to SERVOPACK ON/OFF sequence externally. Be sure to attach a surge absorber (for switching surge) (surge absorber unit etc.) to the excitation coil of the magnetic contactor.

Main Circuit Power Supply	SERVOPACK Model SGDV-	Magnetic Contactor	
		Model	Specifications
Single-phase 100 V	R70F, R90F, 2R1F	SC-03	(RoHS)
	2R8F	SC-4-1	(RoHS)
Three-phase 200 V	R70A, R90A, 1R6A, 2R8A, 3R8A	SC-03	(RoHS)
	5R5A, 7R6A, 120A	SC-4-1	(RoHS)
	180A, 200A	SC-5-1	(RoHS)
	330A, 470A	SC-N1	(RoHS)
	550A	SC-N2	(RoHS)
	590A	SC-N2S	(RoHS)
	780A	SC-N3	(RoHS)
Three-phase 400 V	1R9D, 3R5D, 5R4D	SC-4-1/G	Coil 24 VDC (RoHS)
	8R4D, 120D	SC-5-1/G	Coil 24 VDC (RoHS)
	170D, 260D	SC-N1/G	Coil 24 VDC (RoHS)
	280D, 370D	SC-N2S/G	Coil 24 VDC (RoHS)

Note: Contact Fuji Electric FA Components & Systems Co., Ltd.

●External Dimensions (Units: mm)

· SC-03

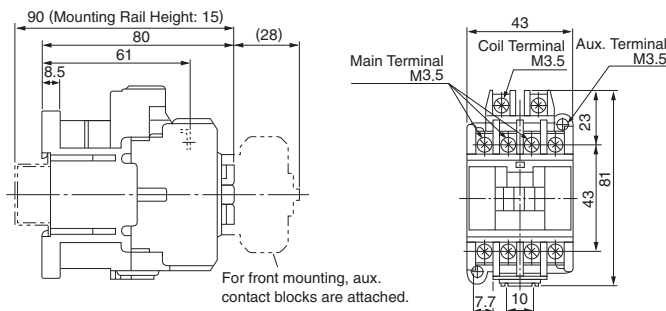

For front mounting, aux. contact blocks are attached.

Mounting Hole Dimensions

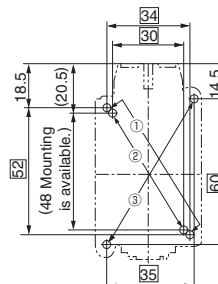

Aux. Contact	Structure
1a	
1b	

● Mounting methods : The following methods ①, ②, ③ are available.

①...34 × (48 to) 52

②...30 × 48

③...35 × 60

● Mounting screw : 2-M4

Use the two mounting holes on the diagonal line to mount a contactor.

Approx. Mass : 0.32 kg

· SC-4-1

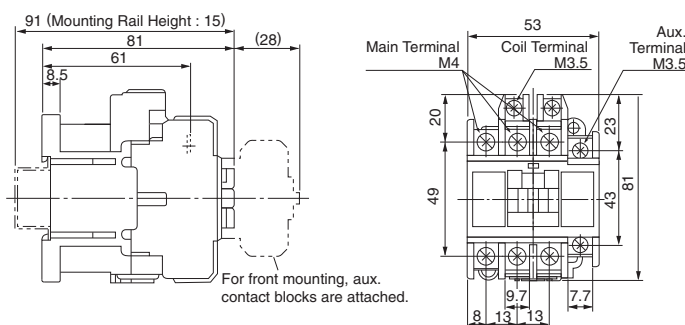

For front mounting, aux. contact blocks are attached.

Mounting Hole Dimensions

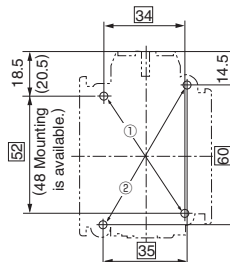

Aux. Contact	Structure
1a	
1b	

● Mounting methods : The following methods ①, ② are available.

①...34 × (48 to) 52

②...35 × 60

● Mounting screw : 2-M4

Use the two mounting holes on the diagonal line to mount a contactor.

Approx. Mass : 0.36 kg

Magnetic Contactor

• SC-5-1

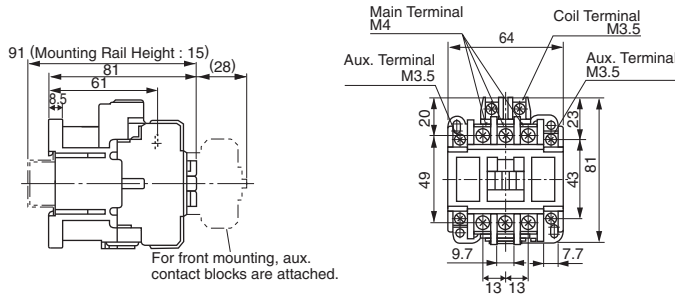

Mounting Hole Dimensions

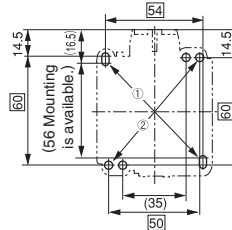

Aux. Contact	Structure
2a	
1a1b	
2b	

- Mounting methods : The following methods ①, ② are available.
①...54 × (56 to) 60
②...50 × 60
- Mounting screw : 2-M4
Use the two mounting holes on the diagonal line to mount a contactor.

Approx. Mass : 0.38 kg

• SC-4-1/G

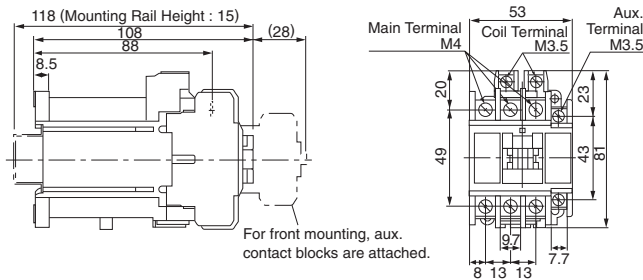

Mounting Hole Dimensions

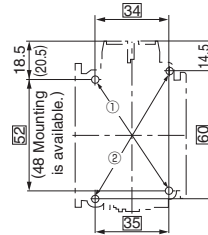

Aux. Contact	Structure
1a	
1b	

- Mounting methods : The following methods ①, ② are available.
①...34 × (48 to) 52
②...35 × 60
- Mounting screw : 2-M4
Use the two mounting holes on the diagonal line to mount a contactor.

Approx. Mass : 0.6 kg

• SC-5-1/G

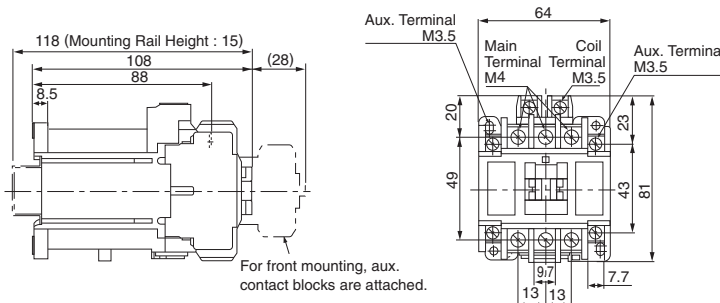

Mounting Hole Dimensions

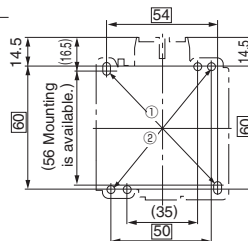

Aux. Contact	Structure
2a	
1a1b	
2b	

- Mounting methods : The following methods ①, ② are available.
①...54 × (56 to) 60
②...50 × 60
- Mounting screw : 2-M4
Use the two mounting holes on the diagonal line to mount a contactor.

Approx. Mass : 0.62 kg

Magnetic Contactor

• SC-N2S/G

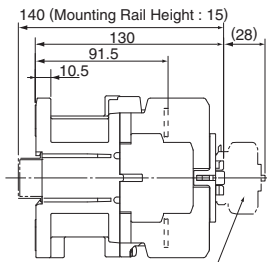

For front mounting, aux. contact blocks are attached.

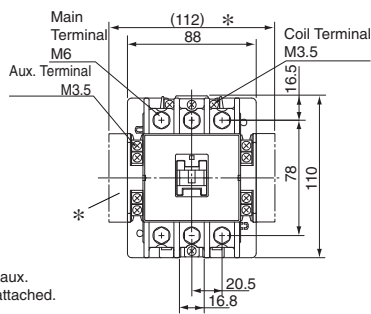

*: For two side mounting, aux. contact blocks are attached.

Mounting Hole Dimensions

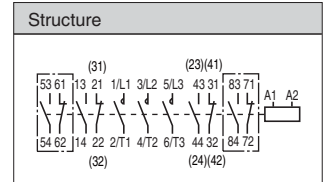
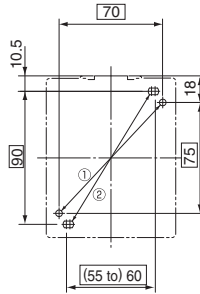

Approx. Mass: 1.4 kg

• Mounting methods : The following methods ①, ② are available.

- ①...70 × 75 ②... (55 to) 65 × 90

• Mounting screw : 2-M4

Use the two mounting holes on the diagonal line to mount a contactor.

• SC-N1, SC-N2

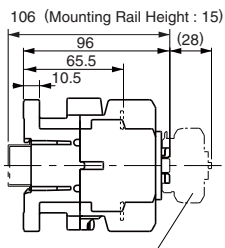

For front mounting, aux. contact blocks are attached.

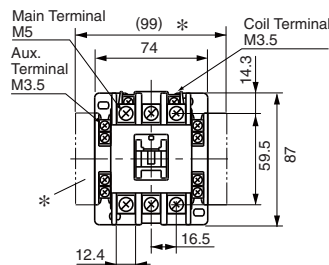

*: For two side mounting, aux. contact blocks attached.

Mounting Hole Dimensions

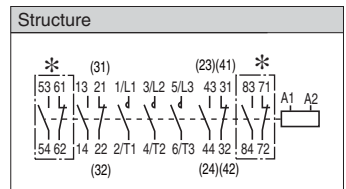
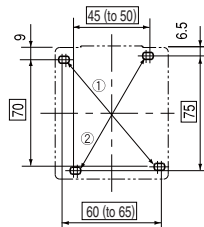

*: These contacts are used if the auxiliary contacts consist of four normally open (NO) and four normally close (NC) contacts.

Note: The terminals of the auxiliary contacts are numbered differently than conventional terminals. The numbers in parentheses use the conventional method.

Approx. Mass: 0.59 kg

• Mounting methods :

The following methods ①, ② are available.

- ①...70 × 75 ②... (55 to) 65 × 90

• Mounting screw : 2-M4

Use the two mounting holes on the diagonal line to mount a contactor.

• SC-N2S, SC-N3

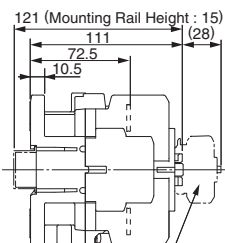

For front mounting, aux. contact blocks are attached.

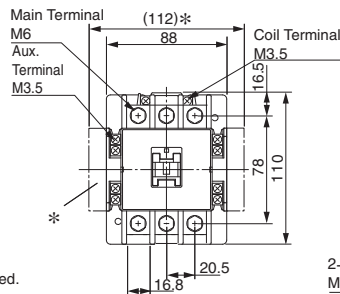

*: For two side mounting, aux. contact blocks attached.

Mounting Hole Dimensions

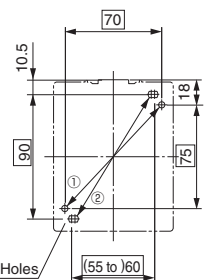

2-M4 Mounting Holes

• Mounting methods :

The following methods ①, ② are available.

- ①...70 × 75 ②... (55 to) 60 × 90

• Mounting screw : 2-M4

Use the two mounting holes on the diagonal line to mount a contactor.

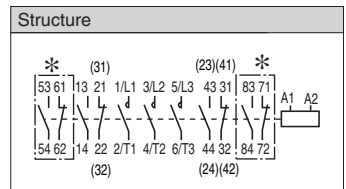

*: These contacts are used if the auxiliary contacts consist of four normally open (NO) and four normally close (NC) contacts.

Note: The terminals of the auxiliary contacts are numbered differently than conventional terminals. The numbers in parentheses use the conventional method.

Approx. Mass: 1.1 kg

• SC-N1/G

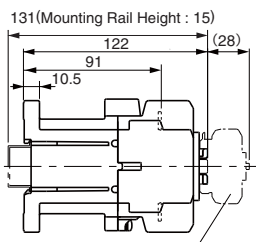

For front mounting, aux. contact blocks are attached.

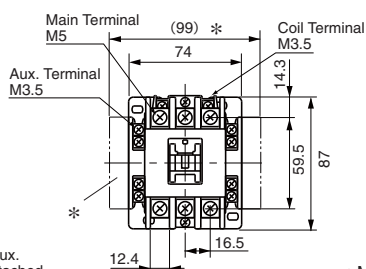

*: For two side mounting, aux. contact blocks attached.

Mounting Hole Dimensions

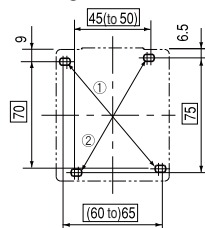

• Mounting methods :

The following methods ①, ② are available

- ①... (60 to) 65 × 70 ②... 45 (to 50) × 70

• Mounting screw : 2-M4

Use the two mounting holes on the diagonal line to mount a contactor.

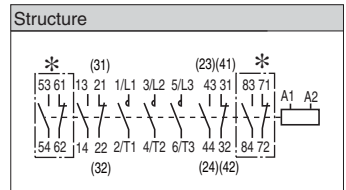

*: These contacts are used if the auxiliary contacts consist of four normally open (NO) and four normally close (NC) contacts.

Note: The terminals of the auxiliary contacts are numbered differently than conventional terminals. The numbers in parentheses use the conventional method.

Approx. Mass: 0.82 kg

AC/DC Reactors

● Selection

If power supply harmonic suppression is needed, connect a DC reactor between the three-phase 200 V or three-phase 400 V SERVOPACK main circuit terminals ⊖1 and ⊖2. Also, connect an AC reactor to single-phase 100 V SERVOPACK main circuit terminal L1 in series.

Select AD/DC reactors according to the SERVOPACK ratings.

Main Circuit Power Supply	SERVOPACK SGD V-	AC/DC Reactor Model	Inductance mH	Rated Current A			
Single-phase 100 V	R70F	X5053	20.0	2.0			
	R90F						
	2R1F	X5054	5.0	3.0			
	2R8F	X5056	2.0	5.0			
Three-phase 200 V	R70A	X5061	2.0	4.8			
	R90A						
	1R6A						
	2R8A						
	3R8A						
	5R5A						
	7R6A	X5060	1.5	8.8			
	120A						
	180A						
	200A				X5059	1.0	14.0
	330A				X5068	0.47	26.8
	470A				-	-	-
550A							
590A							
780A							
Three-phase 400 V	1R9D	X5074	4.7	1.5			
	3R5D	X5075	3.3	4.5			
	5R4D						
	8R4D	X5076	2.2	8.6			
	120D						
	170D				X5077	1.5	14.1
	210D	-	-	-			
	260D						
	280D						
	370D						

Note: RoHS-compliant models are not available. The last digit of an RoHS-compliant model number is R. Contact the manufacturers when selecting an RoHS-compliant model.

● External Dimensions (Units: mm)

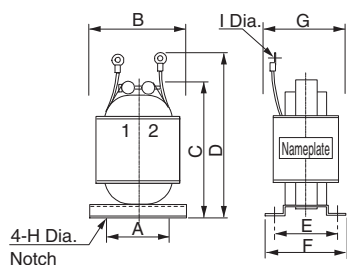

AC/DC Reactor Model	External Dimensions									Approx. Mass kg
	A	B	C	D	E	F	G	H Dia.	I Dia.	
X5053	35	52	90	105	35	45	50	4	4.3	0.6
X5054	35	52	80	95	30	40	45	4	4.5	0.4
X5056	35	52	80	95	30	40	45	4	4.3	0.4
X5059	50	74	125	140	35	45	60	5	5.3	1.1
X5060	40	59	105	140	35	45	60	5	5.3	1.1
X5061	35	52	80	95	35	45	50	4	4.3	0.5
X5068	50	74	125	155	53	66	75	5	6.4	1.9
X5074	30	47	70	85	28	38	45	4	4.3	0.3
X5075	40	59	100	120	40	50	55	4	4.3	0.9
X5076	50	74	125	140	35	45	60	5	4.3	1.1
X5077	50	74	125	155	53	66	75	5	5.3	1.9

Holding Brake Power Supply Unit

● Holding Brake Power Supply Unit

IMPORTANT

- We recommend opening or closing the circuit for the holding brake's power supply so that switching will occur on the AC side of the holding brake power supply unit. This will reduce brake operation time compared to switching on the DC side.
- When switching on the DC side, install an extra surge absorber (for lightning surge) apart from the surge absorber (for lightning surge) built in the brake circuit near the brake coil, in order to prevent damage to the brake coil from surge voltage.
- Holding brake power supply units for 24 VDC are not provided by Yaskawa. Please obtain these from other manufacturers. Do not connect holding brake power supply units for different output voltages to SERVOPACKs. Overcurrent may result in burning.

● **Model**

200 V input: LPSE-2H01-E
 100 V input: LPDE-1H01-E

● **Specifications**

Rated output voltage: 90 VDC
 Maximum output current: DC 1.0 A
 Lead wire length: 500 mm each
 Maximum ambient temperature: 60°C
 Lead wires: Color coded (refer to the table below)

AC input		Brake end
100 V	200 V	
Blue/white	Yellow/white	Red/black

● **External Dimensions (Units: mm)**

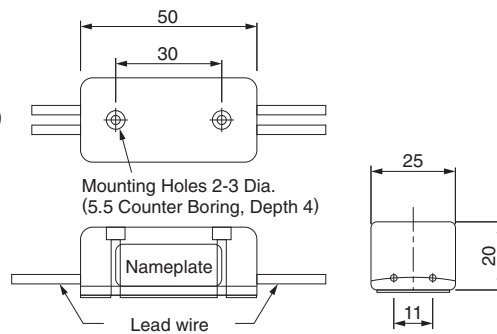

● **Internal Circuits**

We recommend opening or closing the circuit for the holding brake's power supply so that switching will occur on the AC side of the holding brake power supply unit. This will reduce brake operation time compared to switching on the DC side.
 When switching on the DC side, install an extra surge absorber apart from the surge absorber built in the brake circuit near the brake coil, in order to prevent damage to the brake coil from surge voltage.

Brake Power Supply for 200 VAC

Internal Circuit for Model: LPSE-2H01-E

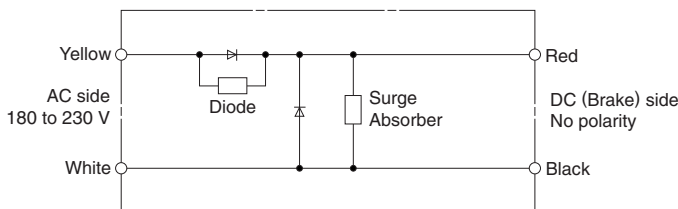

Brake Power Supply for 100 VAC

Internal Circuit for Model: LPDE-1H01-E

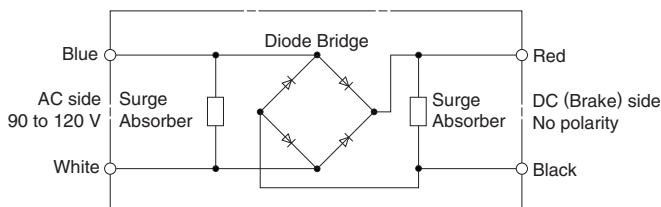

Regenerative Resistors

● Regenerative Power and Regenerative Resistance

The rotational energy of driven machine such as servomotor is returned to the SERVOPACK. This is called regenerative power. The regenerative power is absorbed by charging the smoothing capacitor, but when the chargeable energy is exceeded, the regenerative power is further consumed by the regenerative resistor.

The servomotor is driven in regeneration state in the following circumstances:

- While decelerating to a stop during acceleration and deceleration operation.
- Continuous operation on the vertical axis.
- During continuous operation with the servomotor rotated from the load side (negative load).

A servomotor may not be operated with an overhanging load, which tends to continuously rotate the motor. following figures show a typical example of such a load.

● DO NOT use the servomotor with the Vertical Axis Motor Drive without Counterweight

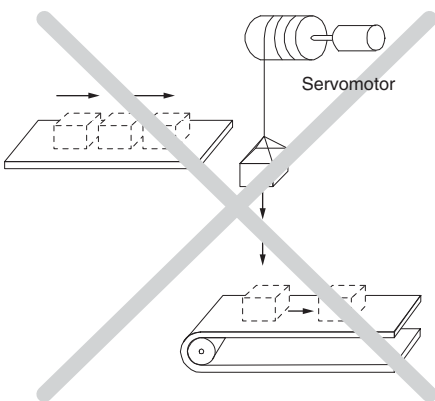

● DO NOT use the servomotor with the Feeding Motor Drive

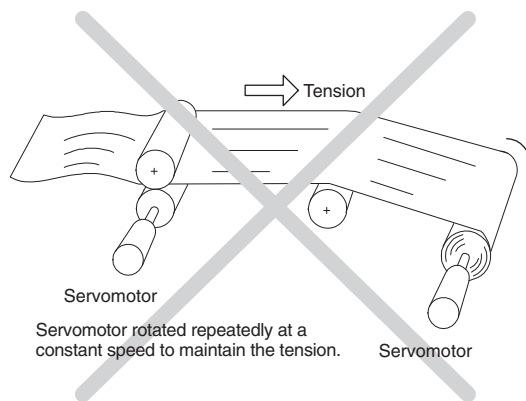

IMPORTANT

- Never operate servomotors with an overhanging load. Doing so will cause the SERVOPACK's regenerative brake to be applied continuously and the regenerative energy of the load may exceed the allowable range causing damage to the SERVOPACK.
- The regenerative brake capacity of the SGD-V SERVOPACKs is rated for short-term operation approximately equivalent to the time it takes to decelerate to a stop.

External regenerative resistors are sometimes required by the AC servo drive capacity selection program SigmaJunmaSize+. When using an external regenerative resistor, parameter Pn600 must be set. For details, refer to *3.6.2 Setting Regenerative Resistor Capacity on "Σ-V Series User's Manual Design and Maintenance."* (manual no. SIEP S800000 45)

● Regenerative Resistor Selection

Select regenerative resistors in the following manner. External resistors are to be provided by users.

Voltage	SERVOPACK Model SGD-V	Built-in Regenerative Resistor	Necessity of External Regenerative Resistors	Necessity of External Regenerative Resistors
Single-phase 100 V	□□□F	None	Basically Not Required	No built-in regenerative resistor is provided, however, normally an external regenerative resistor is not required. Install external regenerative resistors when the smoothing capacitor in SERVOPACK cannot process all the regenerative power.
Three-phase 200 V	R70A, R90A, 1R6A, 2R8A	Standard Equipment*1	Basically Not Required	A built-in regenerative resistor is provided as standard. Install external regenerative resistors when the built-in regenerative resistor cannot process all the regenerative power.
	3R8A, 5R5A, 7R6A 120A, 180A, 200A, 330A			No built-in regenerative resistor is provided, so the external regenerative resistor is required. If the external resistor is not connected with the SERVOPACK, the alarm A.300 is detected as a regeneration error alarm.
Three-phase 400 V	470A, 550A	None	Required*2	A built-in regenerative resistor is provided as standard. Install external regenerative resistors when the built-in regenerative resistor cannot process all the regenerative power.
	590A, 780A	Standard Equipment*1	Basically Not Required	No built-in regenerative resistor is provided, so the external regenerative resistor is required. If the external resistor is not connected with the SERVOPACK, the alarm A.300 is detected as a regeneration error alarm.
	1R9D, 3R5D, 5R4D			No built-in regenerative resistor is provided, so the external regenerative resistor is required. If the external resistor is not connected with the SERVOPACK, the alarm A.300 is detected as a regeneration error alarm.
	8R4D, 120D, 170D	None	Required*2	
	210D, 260D, 280D, 370D	None	Required*2	

*1: For specifications of built-in regenerative resistors, refer to the next page.

*2: Regenerative resistor units are available. For details, refer to page 362.

Regenerative Resistors

● Specifications of Built-in Regenerative Resistor

The following table shows the specifications of the SERVOPACK's built-in resistor and the amount of regenerative power (average values) that it can process.

Applicable SERVOPACK SGDV-	Specifications of Built-in Resistor		Regenerative Power Processed by Built-in Resistor*1 W	Minimum Allowable Resistance Ω	
	Resistance Ω	Capacity W			
Single-phase 100 V	□□□F	—	—	40	
Three-phase 200 V	R70A, R90A, 1R6A, 2R8A	—	—	40	
	3R8A, 5R5A, 7R6A	50	40	8	
	120A	20	50	10	
	180A, 200A	12	80	16	
	330A	8	180	36	
	470A	(6.25)*2	(880)*2	(180)*2	5.8
	550A, 590A, 790A	(3.13)*3	(1760)*3	(350)*3	2.9
Three-phase 400 V	1R9D, 3R5D, 5R4D	108	70	14	
	8R4D, 120D	45	140	28	
	170D	32	180	36	
	210D, 260D	(18)*4	(880)*4	(180)*4	18
	280D, 370D	(14.25)*5	(1760)*5	(350)*5	14.25

*1: The average regenerative power that can be handled is 20% of the rated capacity of the regenerative resistor built into the SERVOPACK.

*2: For the optional JUSP-RA04-E regenerative resistor unit.

*3: For the optional JUSP-RA05-E regenerative resistor unit.

*4: For the optional JUSP-RA18-E regenerative resistor unit.

*5: For the optional JUSP-RA19-E regenerative resistor unit.

● References for External Resistor (by Iwaki Musen Kenkyusho Co., Ltd.)

Model	Specifications
RH120	70 W, 1 to 100 Ω
RH150	90 W, 1 to 100 Ω
RH220□	120 W, 1 to 100 Ω
RH300C	200 W, 1 to 10 kΩ
RH500	300 W, 1 to 30 Ω

Notes: 1 Contact the manufacturers when in need of an RoHS-compliant model.

2 When using an external regenerative resistor, parameter Pn600 must be set.

For details, refer to 3.6.2 Setting Regenerative Resistor Capacity on "Σ-V Series User's Manual Design and Maintenance." (manual no. SIEP S800000 45)

Model	Resistance	Tolerance	
RH120(N)	10Ω	K	
		Code	
		Tolerance	
		K	±10%
		J	±5%
		H	±3%

N: Noninductive Winding

● Specifications

Resistance Tolerance	K : ±10%, J : ±5%, H : ±3%
Temperature Resistance Characteristics	±400PPM / °C (20 Ω max.), ±260PPM / °C (20 Ω min.)
Withstand Voltage	2000 VAC / min. ΔR : ± (0.1%+0.05 Ω)
Insulation Resistance	500 VDC, 20 MΩ min.
Short-time Overload	When 10 times of rated power is applied for five seconds, ΔR : ±(2%+0.05 Ω)
Life	1000 hours of repeating the operation ON for 90 minutes and OFF for 30 minutes, ΔR : ± (5%+0.05 Ω)
Heat Resistance	Not ignite after having applied 10 times of rated power for one minute
Operating temperature	-25°C to +150°C

● External Dimensions (Units: mm)

RH120, 150, 220	RH220B																																												
<table border="1"> <thead> <tr> <th>Model</th> <th>Rated Power</th> <th>Resistance</th> </tr> </thead> <tbody> <tr> <td>RH120</td> <td>70 W</td> <td>1Ω to 100Ω</td> </tr> <tr> <td>RH150</td> <td>90 W</td> <td>1Ω to 100Ω</td> </tr> <tr> <td>RH220</td> <td>120 W</td> <td>1Ω to 100Ω</td> </tr> </tbody> </table> <table border="1"> <thead> <tr> <th>Dimensions</th> <th>A</th> <th>B</th> <th>C</th> <th>D</th> <th>E</th> <th>F</th> <th>G</th> </tr> </thead> <tbody> <tr> <td>RH120</td> <td>182</td> <td>150</td> <td>172</td> <td>16</td> <td>42</td> <td>22</td> <td>20</td> </tr> <tr> <td>RH150</td> <td>212</td> <td>180</td> <td>202</td> <td>16</td> <td>44</td> <td>24</td> <td>30</td> </tr> <tr> <td>RH220</td> <td>230</td> <td>200</td> <td>220</td> <td>15</td> <td>60</td> <td>24</td> <td>20</td> </tr> </tbody> </table>	Model	Rated Power	Resistance	RH120	70 W	1Ω to 100Ω	RH150	90 W	1Ω to 100Ω	RH220	120 W	1Ω to 100Ω	Dimensions	A	B	C	D	E	F	G	RH120	182	150	172	16	42	22	20	RH150	212	180	202	16	44	24	30	RH220	230	200	220	15	60	24	20	<p>Lead wire length : L = 500 Rated power : 120 W Resistance : 1 Ω to 100 Ω</p>
Model	Rated Power	Resistance																																											
RH120	70 W	1Ω to 100Ω																																											
RH150	90 W	1Ω to 100Ω																																											
RH220	120 W	1Ω to 100Ω																																											
Dimensions	A	B	C	D	E	F	G																																						
RH120	182	150	172	16	42	22	20																																						
RH150	212	180	202	16	44	24	30																																						
RH220	230	200	220	15	60	24	20																																						
<p>Lead wire length : L = 300 Rated power : 200 W Resistance : 1 Ω to 10 kΩ</p>	<p>Lead wire length : L = 450 Rated power : 300 W Resistance : 1 Ω to 30 Ω</p>																																												

External Regenerative Resistor

● Regenerative Resistor Unit

SERVOPACK Model SGDv-	Regenerative Resistor Unit Model	Specifications	Allowable Power Loss
470A	JUSP-RA04-E	6.25 Ω , 880 W	180 W
550A, 590A, 780A	JUSP-RA05-E	3.13 Ω , 1760 W	350 W
210D, 260D	JUSP-RA18-E	18 Ω , 880 W	180 W
280D, 370D	JUSP-RA19-E	14.25 Ω , 1760 W	350 W

Note: Only when using the regenerative resistors above, parameter Pn600 does not need to be set.

● External Dimensions

(1) JUSP-RA04-E, -RA05-E

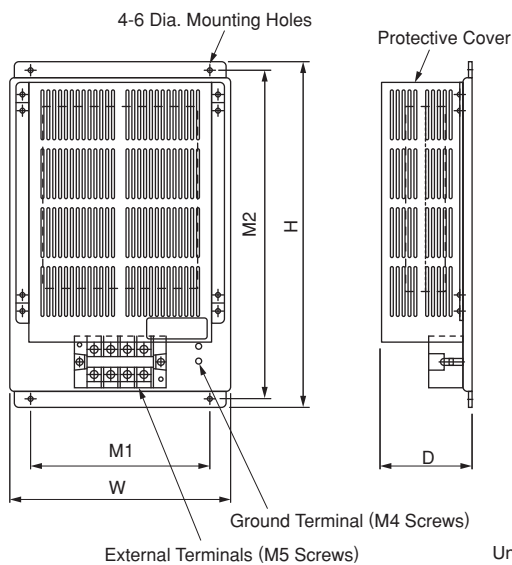

Units: mm

Model	W	H	D	M1	M2	Approx. Mass
JUSP-RA04-E	220	350	92	180	335	4 kg
JUSP-RA05-E	300	350	95	250	335	7 kg

(2) JUSP-RA18-E

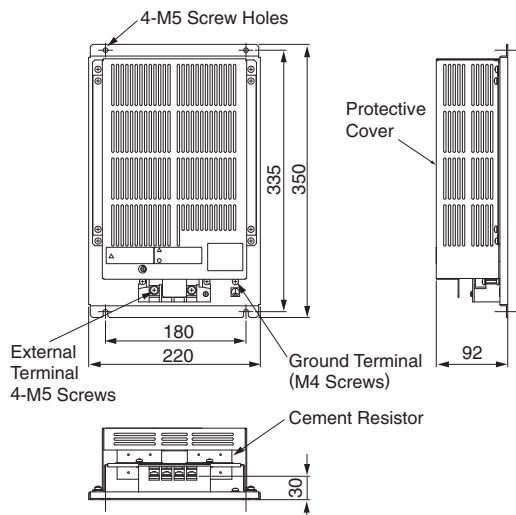

(3) JUSP-RA19-E

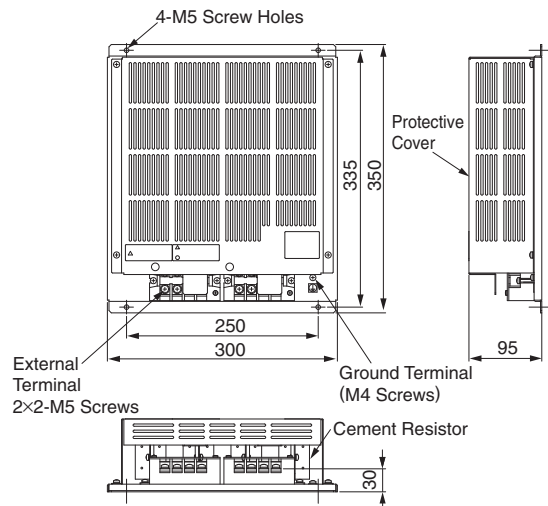



Selecting Servomotor Capacity and Regenerative Capacity

Servomotor Capacity Selection Examples

Use the AC servo drive capacity selection program SigmaJunmaSize+ to select servomotor capacity. The program can be downloaded for free from our web site (<http://www.e-mechatronics.com/>).

● Selection Example for Speed Control

Mechanical Specifications

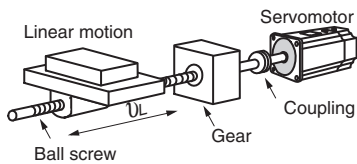

- Load speed: $v_L = 15$ m/min
- Linear motion section mass: $m = 250$ kg
- Ball screw length: $\ell_B = 1.0$ m
- Ball screw diameter: $d_B = 0.02$ m
- Ball screw lead: $P_B = 0.01$ m
- Ball screw material density: $\rho = 7.87 \times 10^3$ kg/m³
- Gear ratio: 1/2 (R = 2)
- Gear + coupling moment of inertia: $J_G = 0.40 \times 10^{-4}$ kg · m²
- Feeding times: $n = 40$ times/min
- Feeding distance: $\ell = 0.275$ m
- Feeding time: $tm = 1.2$ s max.
- Friction coefficient: $\mu = 0.2$
- Mechanical efficiency: $\eta = 0.9$ (90%)

(1) Speed Diagram

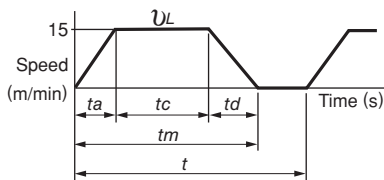

$$t = \frac{60}{n} = \frac{60}{40} = 1.5 \text{ (s)}$$

where $t_a = t_d$

$$t_a = tm - \frac{60\ell}{v_L} = 1.2 - \frac{60 \times 0.275}{15} = 1.2 - 1.1 = 0.1 \text{ (s)}$$

$$t_c = 1.2 - 0.1 \times 2 = 1.0 \text{ (s)}$$

(2) Rotation Speed

• Load axis rotation speed $n_L = \frac{v_L}{P_B} = \frac{15}{0.01} = 1500 \text{ (min}^{-1}\text{)}$

• Motor shaft rotation speed Gear ratio 1/R = 1/2 (R=2)
Therefore, $n_M = n_L \cdot R = 1500 \times 2 = 3000 \text{ (min}^{-1}\text{)}$

(3) Load torque

$$T_L = \frac{9.8\mu \cdot m \cdot P_B}{2\pi R \cdot \eta} = \frac{9.8 \times 0.2 \times 250 \times 0.01}{2\pi \times 2 \times 0.9} = 0.43 \text{ (N} \cdot \text{m)}$$

(4) Load Moment of Inertia

• Linear motion section $J_{L1} = m \left(\frac{P_B}{2\pi R} \right)^2 = 250 \times \left(\frac{0.01}{2\pi \times 2} \right)^2 = 1.58 \times 10^{-4} \text{ (kg} \cdot \text{m}^2\text{)}$

• Ball screw $J_B = \frac{\pi}{32} \rho \cdot \ell_B \cdot d_B^4 \cdot \frac{1}{R^2} = \frac{\pi}{32} \times 7.87 \times 10^3 \times 1.0 \times (0.02)^4 \cdot \frac{1}{2^2} = 0.31 \times 10^{-4} \text{ (kg} \cdot \text{m}^2\text{)}$

• Coupling $J_G = 0.40 \times 10^{-4} \text{ (kg} \cdot \text{m}^2\text{)}$

• Load moment of inertia at motor shaft $J_L = J_{L1} + J_B + J_G = (1.58 + 0.31 + 0.40) \times 10^{-4} = 2.29 \times 10^{-4} \text{ (kg} \cdot \text{m}^2\text{)}$

(5) Load Moving Power

$$P_O = \frac{2\pi n_M \cdot T_L}{60} = \frac{2\pi \times 3000 \times 0.43}{60} = 135 \text{ (W)}$$

Servomotor Capacity Selection Examples

(6) Load Acceleration Power

$$P_a = \left(\frac{2\pi}{60} n_M \right)^2 \frac{J_L}{t_a} = \left(\frac{2\pi}{60} \times 3000 \right)^2 \times \frac{2.29 \times 10^{-4}}{0.1} = 226 \text{ (W)}$$

(7) Servomotor Provisional Selection

- (a) Selecting Conditions
- $T_L \leq$ Motor rated torque
 - $\frac{(P_o + P_a)}{2} <$ Provisionally selected servomotor rated output $< (P_o + P_a)$
 - $n_M \leq$ Motor rated speed
 - $J_L \leq$ Allowable load moment of inertia

The followings satisfy the conditions.

• Servomotor SGMJV-02A

(b) Specifications of the Provisionally Selected Servomotor

- Rated output : 200 (W)
- Rated motor speed : 3000 (min^{-1})
- Rated torque : 0.637 ($\text{N}\cdot\text{m}$)
- Instantaneous peak torque : 2.23 ($\text{N}\cdot\text{m}$)
- Servomotor moment of inertia : 0.259×10^{-4} ($\text{kg}\cdot\text{m}^2$)
- Allowable load moment of inertia : $0.259 \times 10^{-4} \times 15 = 3.885 \times 10^{-4}$ ($\text{kg}\cdot\text{m}^2$)

(8) Verification on the Provisionally Selected Servomotor

$$\begin{aligned} \text{• Required acceleration torque: } T_P &= \frac{2\pi n_M (J_M + J_L)}{60 t_a} + T_L = \frac{2\pi \times 3000 \times (0.259 + 2.29) \times 10^{-4}}{60 \times 0.1} + 0.43 \\ &\cong 1.23 \text{ (N}\cdot\text{m)} < \text{Instantaneous peak torque} \cdots \text{Satisfactory} \end{aligned}$$

$$\begin{aligned} \text{• Required deceleration torque: } T_S &= \frac{2\pi n_M (J_M + J_L)}{60 t_d} - T_L = \frac{2\pi \times 3000 \times (0.259 + 2.29) \times 10^{-4}}{60 \times 0.1} - 0.43 \\ &\cong 0.37 \text{ (N}\cdot\text{m)} < \text{Instantaneous peak torque} \cdots \text{Satisfactory} \end{aligned}$$

$$\begin{aligned} \text{• Torque effective value: } T_{rms} &= \sqrt{\frac{T_P^2 \cdot t_a + T_L^2 \cdot t_c + T_S^2 \cdot t_d}{t}} = \sqrt{\frac{(1.23)^2 \times 0.1 + (0.43)^2 \times 1.0 + (0.37)^2 \times 0.1}{1.5}} \\ &\cong 0.483 \text{ (N}\cdot\text{m)} < \text{Rated torque} \cdots \text{Satisfactory} \end{aligned}$$

(9) Result

The provisionally selected servomotor is confirmed to be applicable.
The torque diagram is shown below.

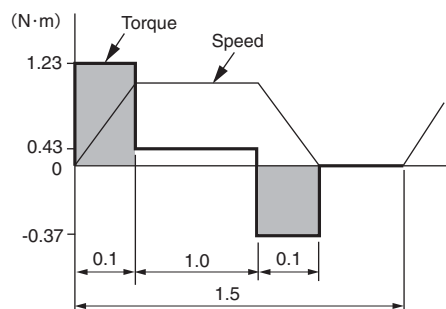

Servomotor Capacity Selection Examples

Use the AC servo drive capacity selection program SigmaJunmaSize+ to select servomotor capacity. The program can be downloaded for free from our web site (<http://www.e-mechatronics.com/>).

● Selection Example for Position Control

Mechanical Specifications

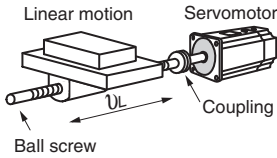

- Load speed: $v_L = 15$ m/min
- Linear motion section mass: $m = 80$ kg
- Ball screw length: $l_B = 0.8$ m
- Ball screw diameter: $d_B = 0.016$ m
- Ball screw lead: $P_B = 0.005$ m
- Ball screw material density: $\rho = 7.87 \times 10^3$ kg/m³
- Coupling mass: $m_C = 0.3$ kg
- Coupling outer diameter: $d_C = 0.03$ m
- Positioning times: $n = 40$ times/min
- Positioning distance: $l = 0.25$ m
- Positioning time: $t_m = 1.2$ s max.
- Electrical stop accuracy: $\delta = \pm 0.01$ mm
- Friction coefficient: $\mu = 0.2$
- Mechanical efficiency: $\eta = 0.9$ (90%)

(1) Speed Diagram

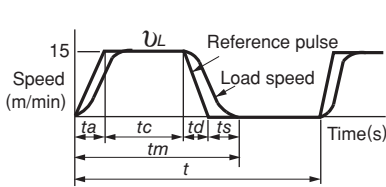

$$t = \frac{60}{n} = \frac{60}{40} = 1.5(\text{s})$$

$$\text{Where } t_a = t_d, t_s = 0.1(\text{s})$$

$$t_a = t_m - t_s - \frac{60l}{v_L} = 1.2 - 0.1 - \frac{60 \times 0.25}{15} = 0.1(\text{s})$$

$$t_c = 1.2 - 0.1 - 0.1 \times 2 = 0.9(\text{s})$$

(2) Rotation Speed

- Load axis rotation speed $n_L = \frac{v_L}{P_B} = \frac{15}{0.005} = 3000(\text{min}^{-1})$

- Motor shaft rotation speed with direct coupling: Gear ratio $1/R = 1/1$

$$\text{Therefore, } n_M = n_L \cdot R = 3000 \times 1 = 3000 (\text{min}^{-1})$$

(3) Load Torque

$$T_L = \frac{9.8\mu \cdot m \cdot P_B}{2\pi R \cdot \eta} = \frac{9.8 \times 0.2 \times 80 \times 0.005}{2\pi \times 1 \times 0.9} = 0.139(\text{N}\cdot\text{m})$$

(4) Load Moment of Inertia

- Liner motion section $J_{L1} = m \left(\frac{P_B}{2\pi R} \right)^2 = 80 \times \left(\frac{0.005}{2\pi \times 1} \right)^2 = 0.507 \times 10^{-4}(\text{kg}\cdot\text{m}^2)$

- Ball screw $J_B = \frac{\pi}{32} \rho \cdot l_B \cdot d_B^4 = \frac{\pi}{32} \times 7.87 \times 10^3 \times 0.8 \times (0.016)^4 = 0.405 \times 10^{-4}(\text{kg}\cdot\text{m}^2)$

- Coupling $J_C = \frac{1}{8} m_C \cdot d_C^2 = \frac{1}{8} \times 0.3 \times (0.03)^2 = 0.338 \times 10^{-4}(\text{kg}\cdot\text{m}^2)$

- Load moment of inertia at the motor shaft

$$J_L = J_{L1} + J_B + J_C = 1.25 \times 10^{-4}(\text{kg}\cdot\text{m}^2)$$

Servomotor Capacity Selection Examples

(5) Load Moving Power

$$P_o = \frac{2\pi n_M \cdot T_L}{60} = \frac{2\pi \times 3000 \times 0.139}{60} = 43.7(\text{W})$$

(6) Load Acceleration Power

$$P_a = \left(\frac{2\pi}{60} n_M \right)^2 \frac{J_L}{t_a} = \left(\frac{2\pi}{60} \times 3000 \right)^2 \times \frac{1.25 \times 10^{-4}}{0.1} = 123.4(\text{W})$$

(7) Provisionally Servomotor Selection

- (a) Selecting Conditions
- $T_L \leq$ Motor rated torque
 - $\frac{(P_o + P_a)}{2} <$ Provisionally selected servomotor rated output $< (P_o + P_a)$
 - $n_M \leq$ Motor rated speed
 - $J_L \leq$ Allowable load moment of inertia

The followings satisfy the conditions.

- Servomotor SGMJV-01A

(b) Specifications of Servomotor

- Rated output : 100 (W)
- Rated motor speed : 3000 (min^{-1})
- Rated torque : 0.318 ($\text{N} \cdot \text{m}$)
- Instantaneous peak torque : 1.11 ($\text{N} \cdot \text{m}$)
- Servomotor rotor moment of inertia : 0.0665×10^{-4} ($\text{kg} \cdot \text{m}^2$)
- Allowable load moment of inertia : $0.0665 \times 10^{-4} \times 20 = 1.33 \times 10^{-4}$ ($\text{kg} \cdot \text{m}^2$)
- Encoder resolution : 20 bit (1048576P/rev)

(8) Verification on Provisionally Selected Servomotor

$$\begin{aligned} \cdot \text{Required acceleration torque: } T_P &= \frac{2\pi n_M (J_M + J_L)}{60 t_a} + T_L = \frac{2\pi \times 3000 \times (0.0665 + 1.25) \times 10^{-4}}{60 \times 0.1} + 0.139 \\ &\cong 0.552 (\text{N} \cdot \text{m}) < \text{Instantaneous peak torque} \cdots \text{Satisfactory} \end{aligned}$$

$$\begin{aligned} \cdot \text{Required deceleration torque: } T_S &= \frac{2\pi n_M (J_M + J_L)}{60 t_d} - T_L = \frac{2\pi \times 3000 \times (0.0665 + 1.25) \times 10^{-4}}{60 \times 0.1} - 0.139 \\ &\cong 0.275 (\text{N} \cdot \text{m}) < \text{Instantaneous peak torque} \cdots \text{Satisfactory} \end{aligned}$$

$$\begin{aligned} \cdot \text{Torque effective value: } T_{rms} &= \sqrt{\frac{T_P^2 \cdot t_a + T_L^2 \cdot t_c + T_S^2 \cdot t_d}{t}} = \sqrt{\frac{(0.552)^2 \times 0.1 + (0.139)^2 \times 0.9 + (0.275)^2 \times 0.1}{1.5}} \\ &\cong 0.192 (\text{N} \cdot \text{m}) < \text{Rated torque} \cdots \text{Satisfactory} \end{aligned}$$

The above confirms that the provisionally selected servomotor is sufficient. In the next step, their performance in position control are checked.

Servomotor Capacity Selection Examples

(9) PG Feedback Pulse Dividing Ratio: Setting of Electronic Gear Ratio $\left(\frac{B}{A}\right)$

As the electrical stop accuracy $\delta = \pm 0.01\text{mm}$, take the position detection unit $\Delta\ell = 0.01\text{mm/pulse}$.

$$\frac{P_B}{\Delta\ell} \times \left(\frac{B}{A}\right) = \frac{5}{0.01} \times \left(\frac{B}{A}\right) = 1048576$$

$$k = \left(\frac{B}{A}\right) = \frac{1048576}{500}$$

(10) Reference Pulse Frequency

$$v_s = \frac{1000v_L}{60 \times \Delta\ell} = \frac{1000 \times 15}{60 \times 0.01} = 25,000(\text{pps})$$

(11) Error Counter Pulses

Position loop gain $K_P = 40$ (1/s)

$$\varepsilon = \frac{v_s}{K_P} = \frac{25,000}{40} = 625(\text{pulse})$$

(12) Electrical Stop Accuracy

$$\pm\Delta\varepsilon = \pm \frac{\varepsilon}{(\text{SERVOPACK control range}) \times \frac{n_M}{n_R}} = \pm \frac{625}{5000 \times \frac{3000}{3000}} = \pm 0.125 < \pm 1(\text{pulse}) = \pm 0.01(\text{mm})$$

The above results confirm that the selected servomotor is applicable for the position control.

Selecting Regenerative Resistors

(1) Simple Calculation

When driving a servomotor with the horizontal axis, check the external regenerative resistor requirements using the calculation method shown below.

(a) SGD V-□□□F, -R70A, -R90A, -1R6A, and -2R8A SERVOPACKs

These SERVOPACKs do not have built-in regenerative resistors. The energy that can be charged with capacitors is shown in the following table. If the rotational energy in the servomotor exceeds these values, then connect an external regenerative resistor.

Voltage	Applicable SERVOPACK	Regenerative Energy that Can be Processed (joules)	Remarks
Single-phase 100 V	SGDV-R70F, R90F, 2R1F	26.4	Value when main circuit input voltage is 100 VAC
	SGDV-2R8F	44.1	
Three-phase 200V	SGDV-R70A, -R90A, -1R6A	24.2	Value when main circuit input voltage is 200 VAC
	SGDV-2R8A	31.7	

Calculate the rotational energy (E_s) in the servomotor from the following equation:

$$E_s = J \times (nM)^2 / 182 \text{ (joules)}$$

$$\cdot J = J_M + J_L$$

• J_M : Servomotor rotor moment of inertia ($\text{kg}\cdot\text{m}^2$)

• J_L : Load converted to shaft moment of inertia ($\text{kg}\cdot\text{m}^2$)

• nM : Rotation speed used by servomotor (min^{-1})

(b) SGD V-3R8A, -5R5A, -7R6A, -120A, -180A, -200A, -330A, -1R9D, -3R5D, -5R4D, -8R4D, -120D, -170D SERVOPACKs

These SERVOPACKs have built-in regenerative resistors. The allowable frequencies for just the servomotor in acceleration and deceleration operation, during the rotation speed cycle from 0 (min^{-1}) to the maximum rotation speed to 0, are summarized in the following table.

Convert the data into the values obtained with actual rotation speed and load moment of inertia to determine whether an external regenerative resistor is needed.

Voltage	Servomotor Model	Allowable Frequencies in Regenerative Mode (time/min)													
		03	05	06	08	09	10	13	15	20	25	30	40	44	50
Three-phase 200 V	SGMJV-□□	-	-	-	15	-	-	-	-	-	-	-	-	-	-
	SGMAV-□□	-	-	74	31	-	20	-	-	-	-	-	-	-	-
	SGMPS-□□	-	-	-	11	-	-	-	7	-	-	-	-	-	-
	SGMGV-□□A	39	29	-	-	6	-	6	-	7	-	9*	-	6	-
	SGMSV-□□A	-	-	-	-	-	13	-	21	28	21	10	16	-	12
Three-phase 400V	SGMGV-□□D	68	51	-	-	10	-	8	-	13	-	7	-	6	-
	SGMSV-□□D	-	-	-	-	-	24	-	30	49	38	17	16	-	12

*: This value is "4," when used in combination with SGD V-200A SERVOPACK.

Selecting Regenerative Resistors

Operating Conditions for Allowable Regenerative Frequency Calculation

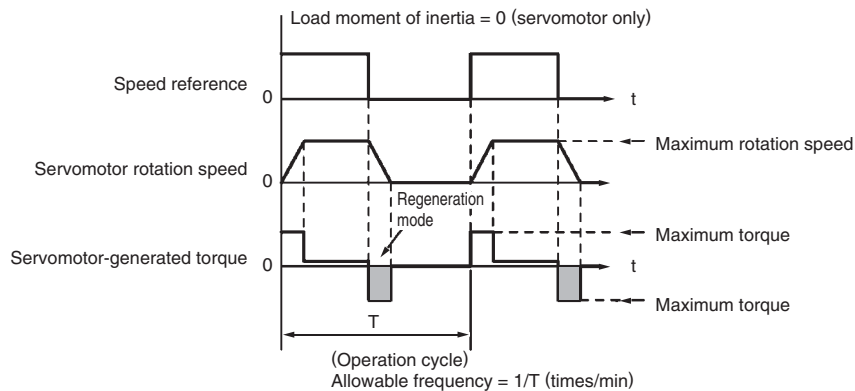

Use the following equation to calculate the allowable frequency for regeneration mode operation

$$\text{Allowable frequency} = \frac{\text{Allowable frequency for Servomotor only}}{(1+n)} \times \left(\frac{\text{Max. rotation speed}}{\text{Rotation speed}} \right)^2 \text{ (time/min)}$$

- $n = J_L / J_M$
- J_M : Servomotor rotor moment of inertia ($\text{kg}\cdot\text{m}^2$)
- J_L : Load converted to shaft moment of inertia ($\text{kg}\cdot\text{m}^2$)

(c) SGD V-470A, -550A, -590A, -780A, -210D, -260D, -280D, -370D SERVOPACKs

These SERVOPACKs do not have built-in regenerative resistors. The following table shows the allowable regenerative frequencies when the JUSP-RA04-E, JUSP-RA05-E, JUSP-RA18-E or JUSP-RA19-E regenerative resistor is used together with an applicable SERVOPACK.

The servomotor driving conditions and the conversion equation for the allowable regenerative frequencies to the rotation speed and load moment of inertia are the same as that shown in (b) on the previous page.

Voltage	Servomotor Model	Allowable Frequencies in Regenerative Mode (time/min)				
		55	70	75	1A	1E
Three-phase 200 V	SGMGV-□□A	24	–	34	39	31
	SGMSV-□□A	–	124	–	–	–
Three-phase 400 V	SGMGV-□□D	24	–	17	39	31

Selecting Regenerative Resistors

(2) Calculating the Regenerative Energy

This section shows the procedure for calculating the regenerative resistor capacity when acceleration and deceleration operation is as shown in the following diagram

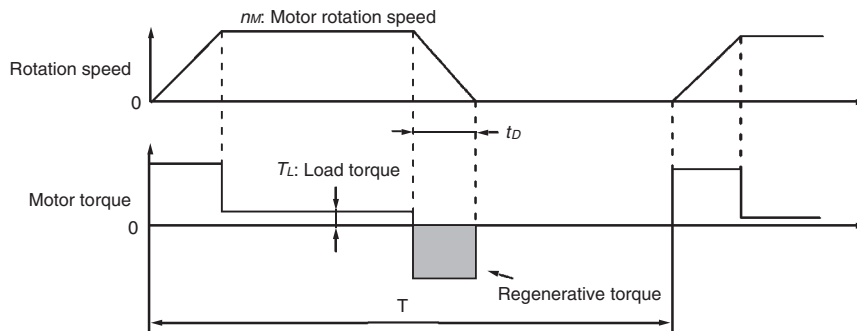

• Calculation Procedure

The procedure for calculating the regenerative capacity is as follows:

Step	Item	Symbol	Equation
1	Calculate the rotational energy of the servomotor.	E_s	$E_s = JnM^2 / 182$
2	Calculate the energy consumed by load loss during the deceleration period	E_L	$E_L = (\pi/60)nMT_L t_D$
3	Calculate the energy lost from servomotor winding resistance.	E_M	(Value calculated from (4) <i>Servomotor Winding Resistance Loss</i> diagrams) $\times t_D$
4	Calculate the SERVOPACK energy that can be absorbed.	E_C	Calculate from (3) <i>SERVOPACK's Absorbable Energy</i> diagrams.
5	Calculate the energy consumed by the regenerative resistor.	E_K	$E_K = E_s - (E_L + E_M + E_C)$
6	Calculate the required regenerative resistor capacity (W).	W_K	$W_K = E_K / (0.2 \times T)$

Note: 1 The "0.2" in the equation for calculating W_K is the value for when the regenerative resistor's utilized load ratio is 20%.

2 The units for the various symbols are as follows:

E_s to E_K : Energy joules (J)

W_K : Regenerative resistor required capacity (W)

J : ($= J_M + J_L$) (kg·m²)

nM : Servomotor rotation speed (min⁻¹)

T_L : Load torque (N·m)

t_D : Deceleration stopping time (s)

T : Servomotor repeat operation period (s)

If the above calculation determines that the amount of regenerative power (W_K) processed by the built-in resistor is not exceeded, then an external regenerative resistor is not required. Refer to *Specifications of Built-in Regenerative Resistor* on page 361 for regenerative resistors built into SERVOPACKs. If the amount of regenerative power that can be processed by the built-in resistor is exceeded, then install an external regenerative resistor for the capacity (W) obtained from the above calculation.

If the energy consumed by load loss (in step 2 above) is unknown, then perform the calculation using $E_L = 0$.

When the operation period in regeneration mode is continuous, add the following items to the above calculation procedure in order to find the required capacity (W) for the regenerative resistor.

- Energy for continuous regeneration mode operation period: E_G (joules)
- Energy consumed by regenerative resistor: $E_K = E_s - (E_L + E_M + E_C) + E_G$
- Required capacity of regenerative resistor: $W_K = E_K / (0.2 \times T)$

Here, $E_G = (2\pi/60) nMG T_G t_G$

- T_G : Servomotor's generated torque in continuous regeneration mode operation period (N·m)
- nMG : Servomotor rotation speed for same operation period as above (min⁻¹)
- t_G : Same operation period as above (s)

Selecting Regenerative Resistors

(3) SERVOPACK's Absorbable Energy

The following diagrams show the relationship between the SERVOPACK's input power supply voltage and its absorbable energy.

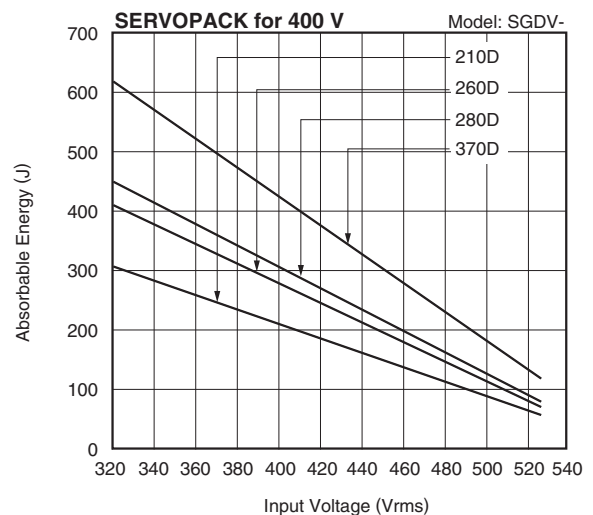
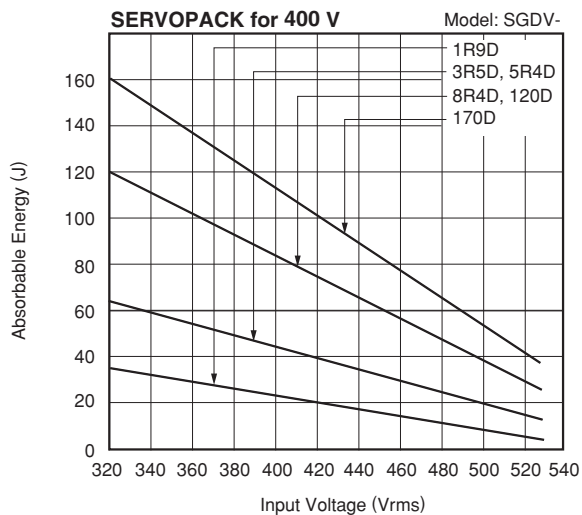
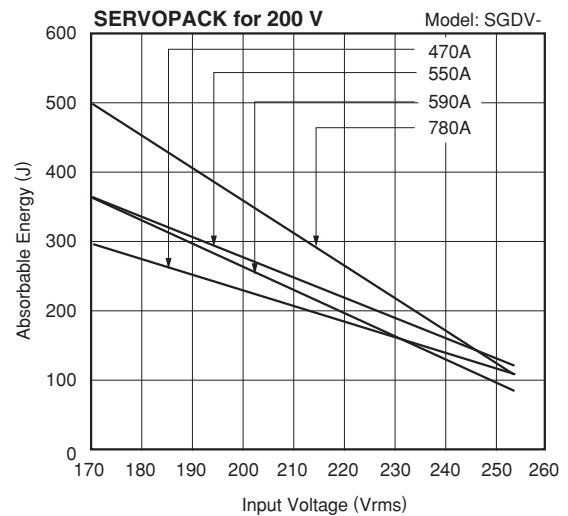
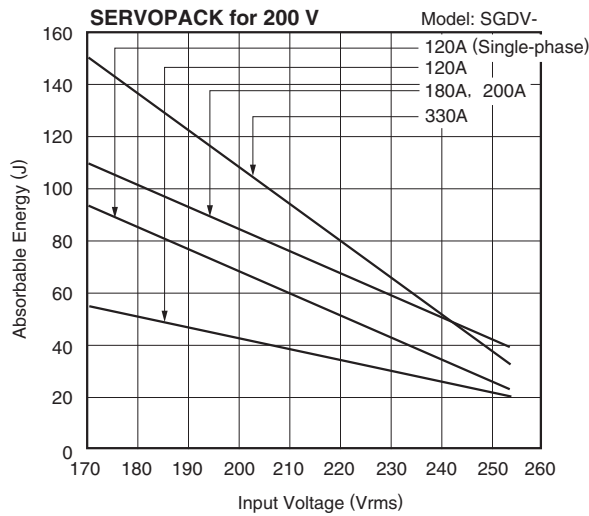
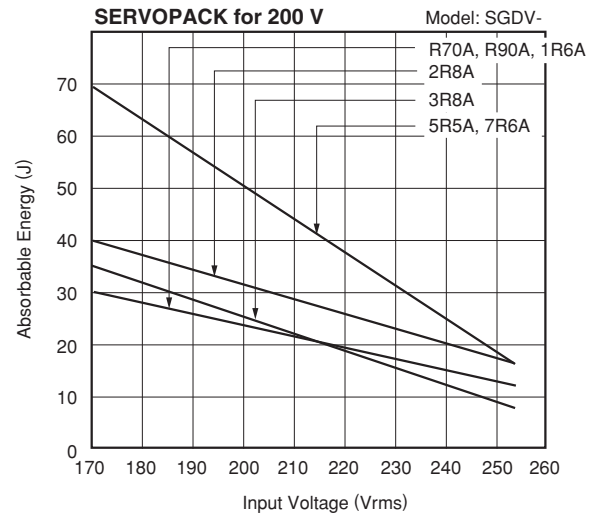
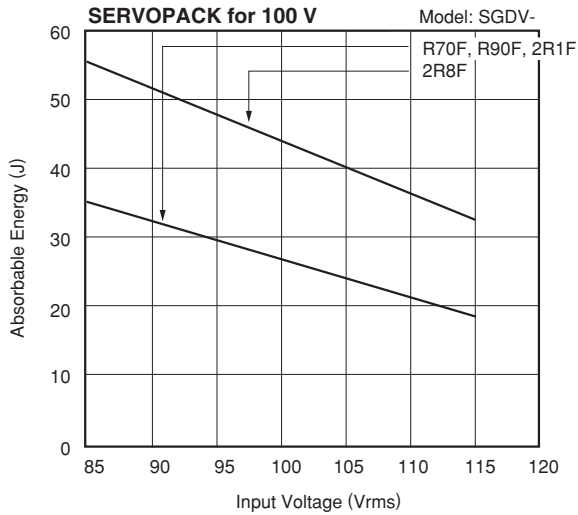

Selecting Regenerative Resistors

(4) Servomotor Winding Resistance Loss

The following diagrams show the relationship, for each servomotor, between the servomotor's generated torque and the winding resistance loss.

(a) SGMJV Rotary Servomotors

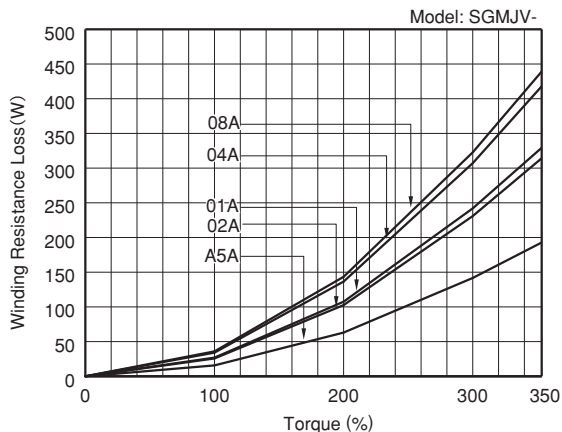

(b) SGMAV Rotary Servomotors

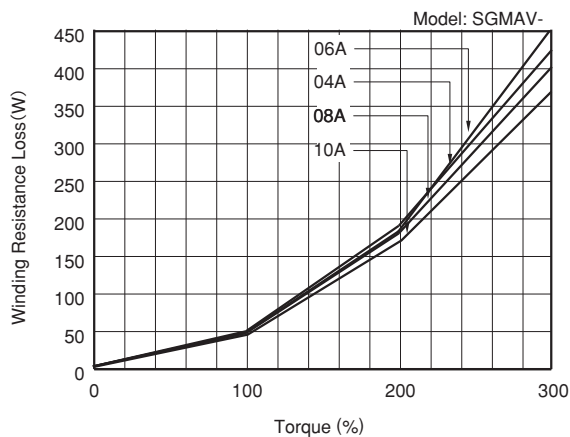
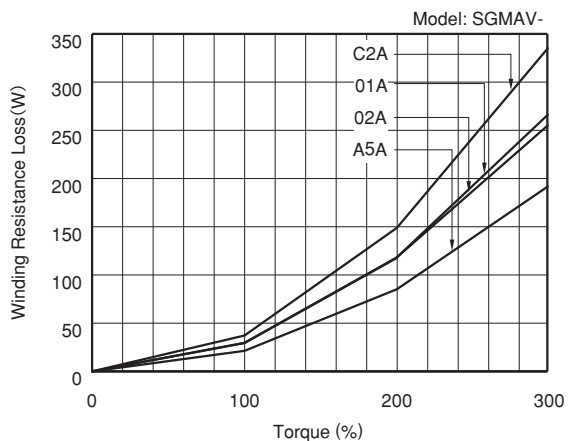

(c) SGMPS Rotary Servomotors

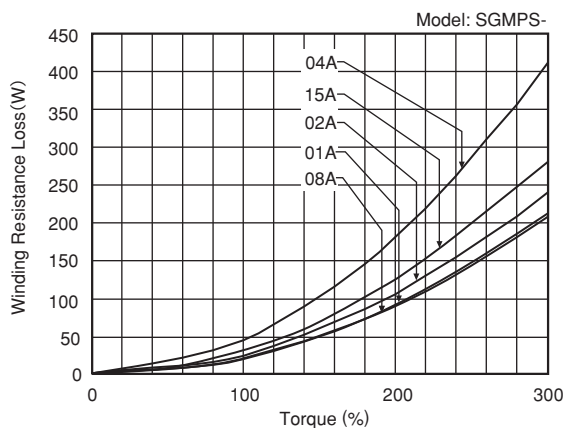

Selecting Regenerative Resistors

(d) SGMGV Rotary Servomotors

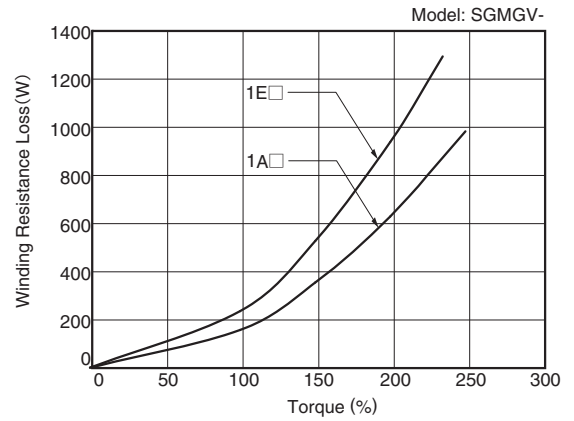
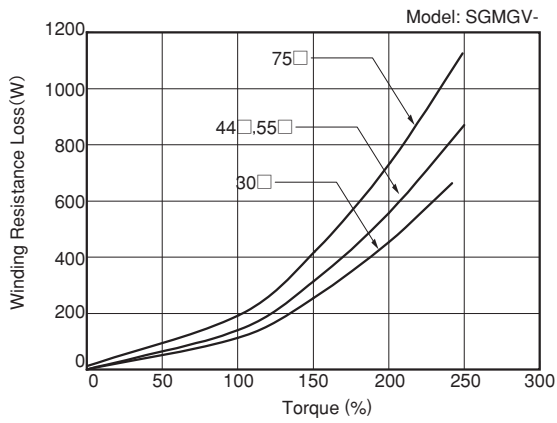
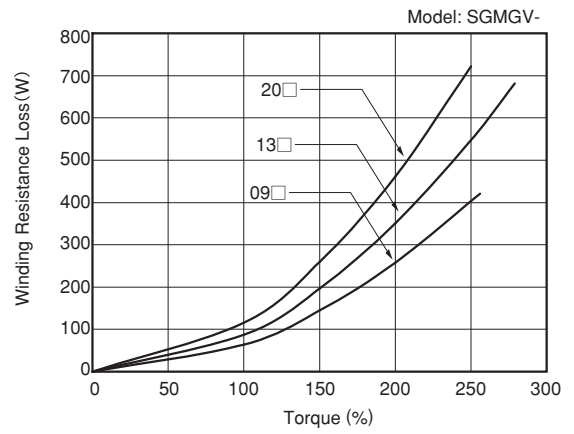
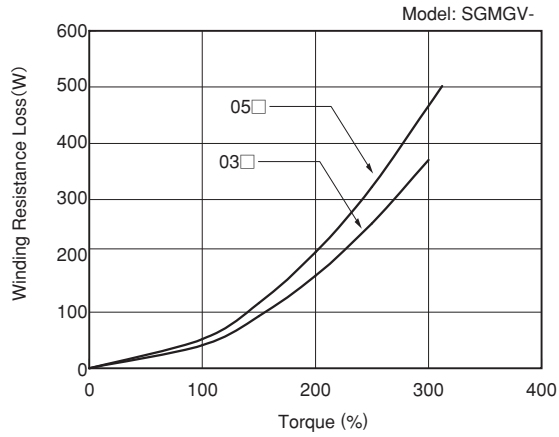

(e) SGMSV Rotary Servomotors

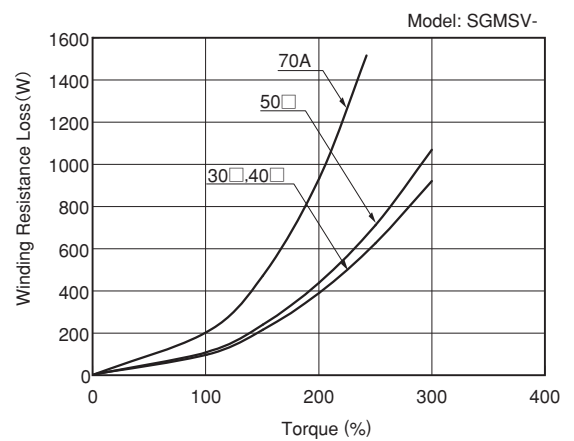
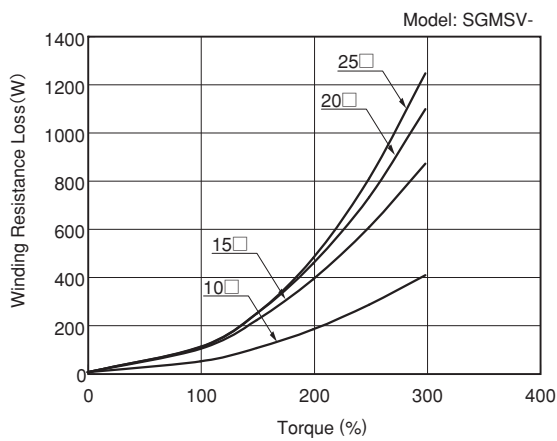

Selecting Regenerative Resistors

(f) SGMCS Direct Drive Servomotors

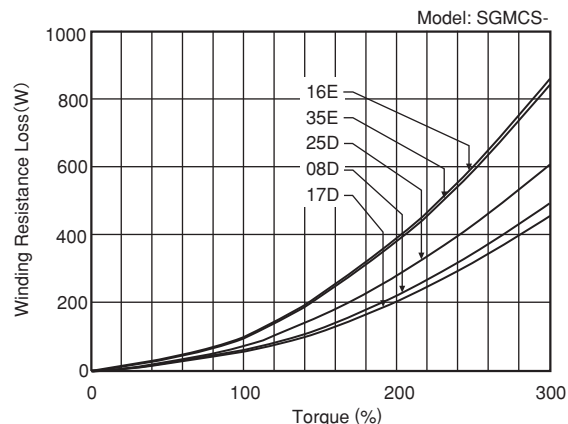
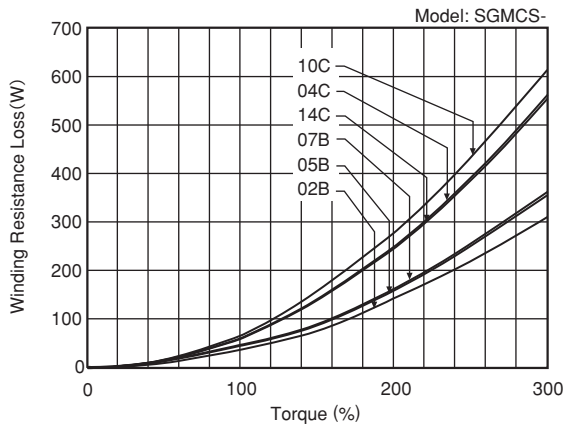

(g) SGLGW Linear Servomotors

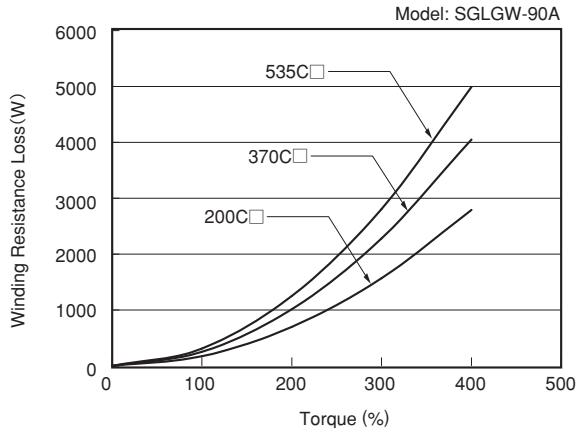
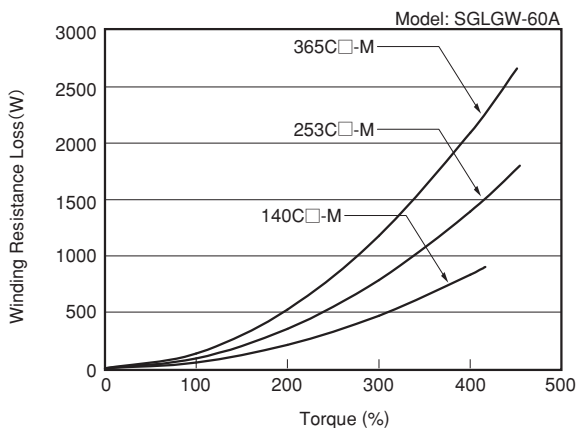
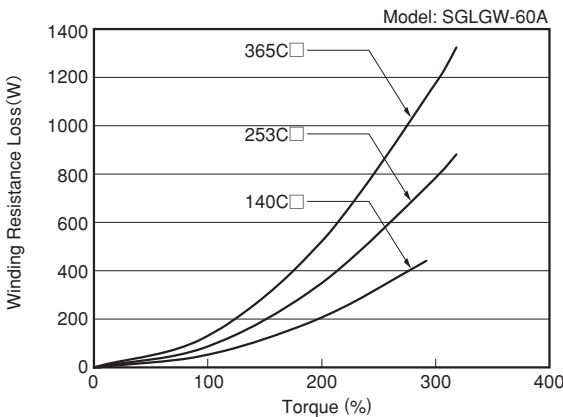
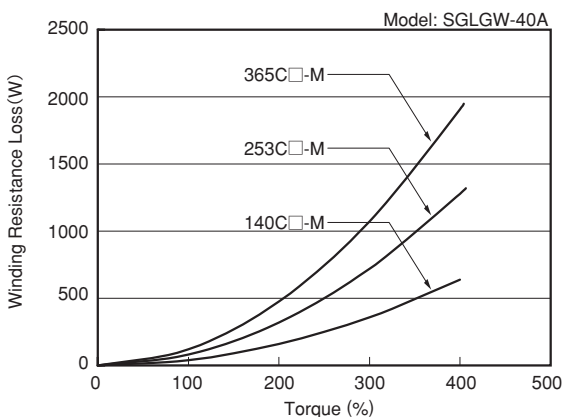
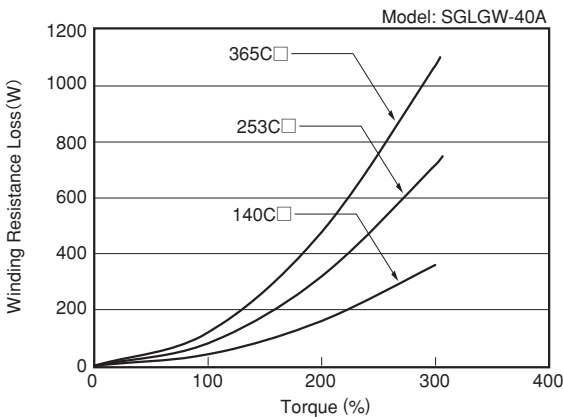
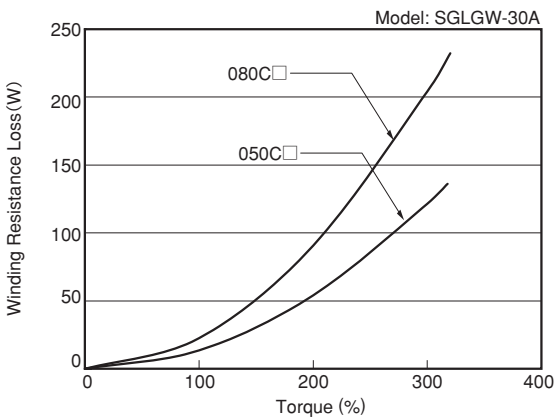

Selecting Regenerative Resistors

(h) SGLFW Linear Servomotors

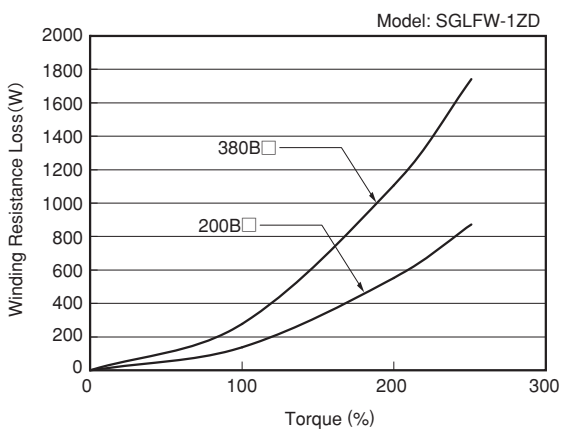
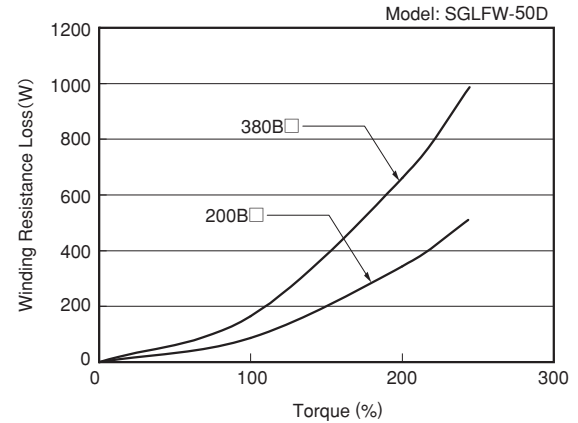
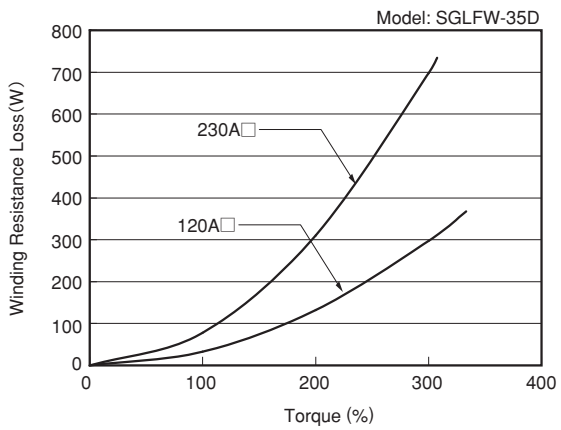
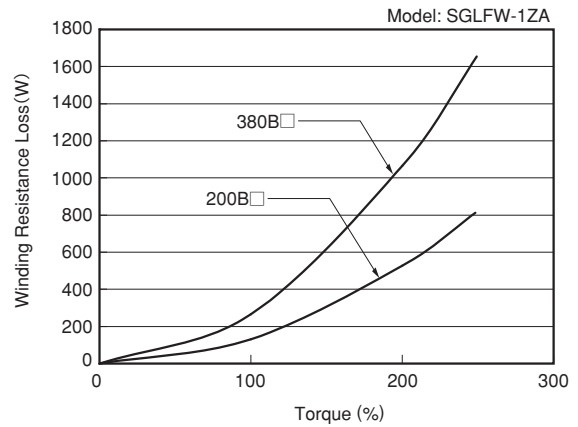
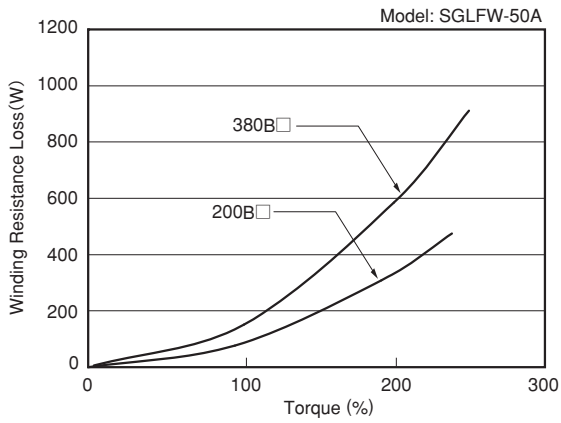
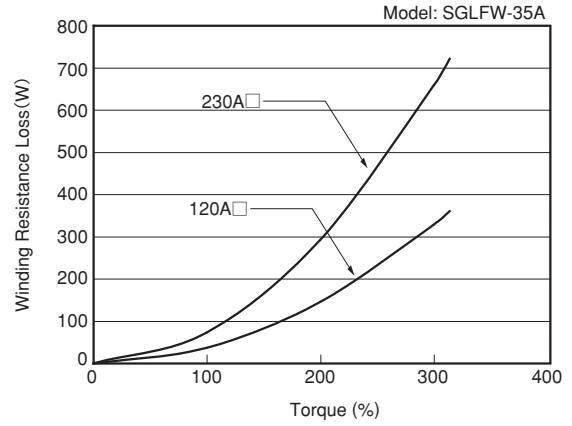
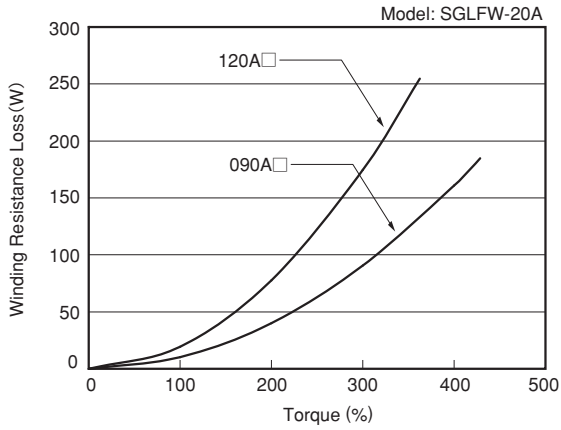

Selecting Regenerative Resistors

(i) SGLTW Linear Servomotors

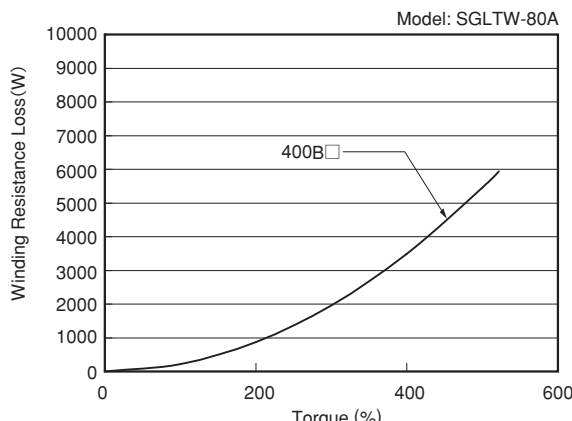
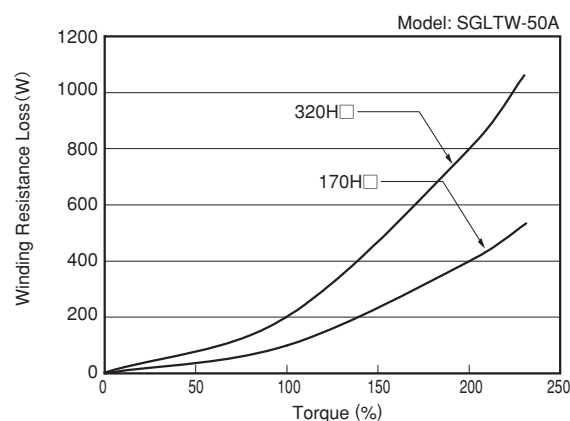
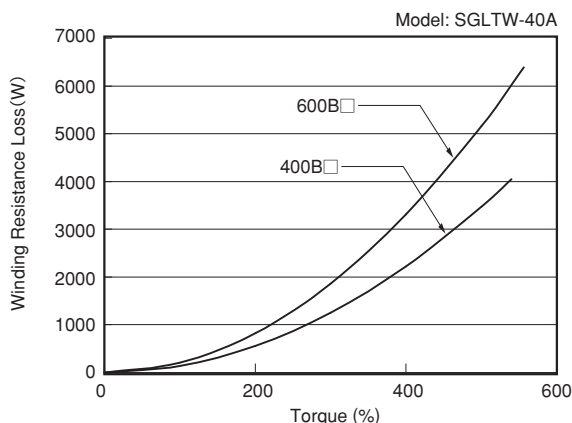
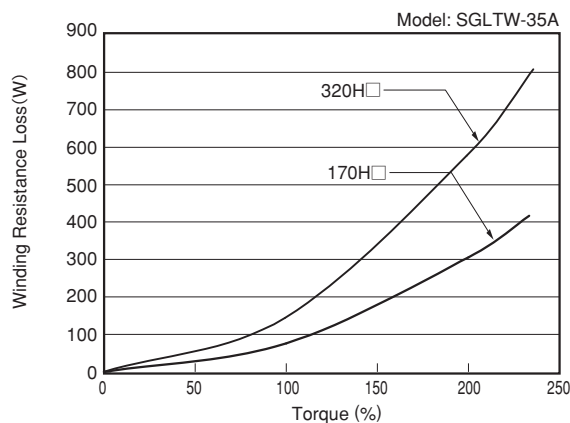
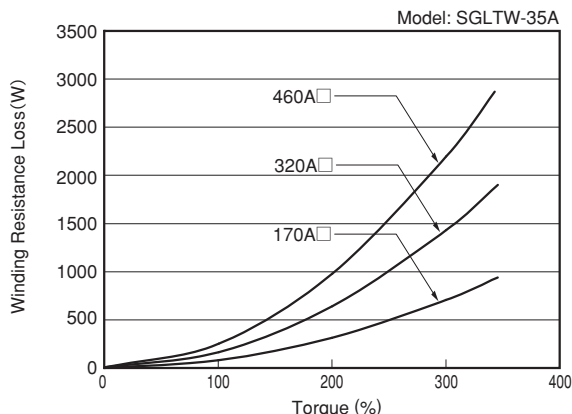
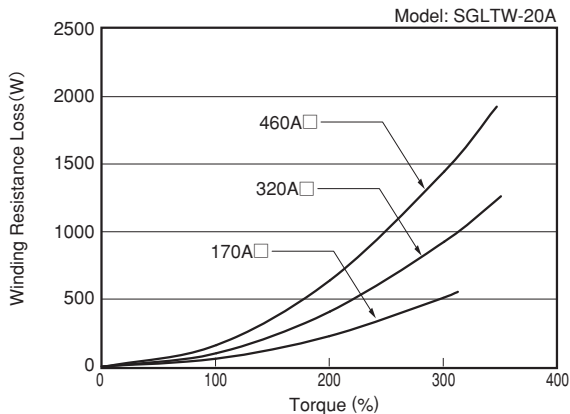

Selecting Regenerative Resistors

(i) SGLTW Linear Servomotors (cont'd)

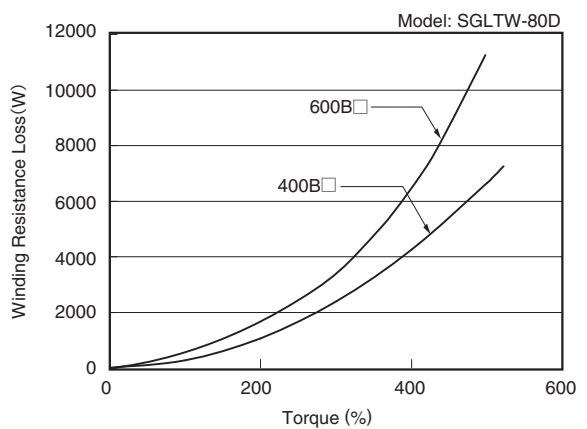
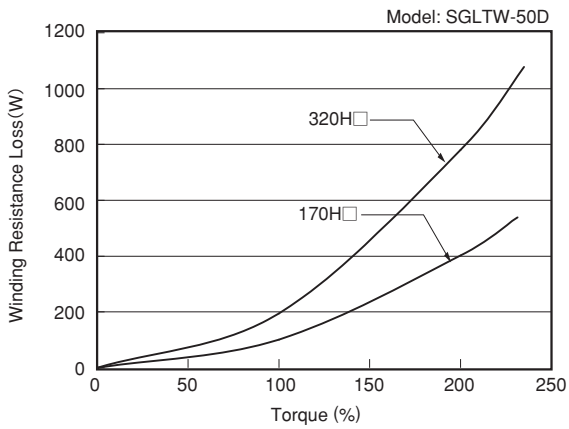
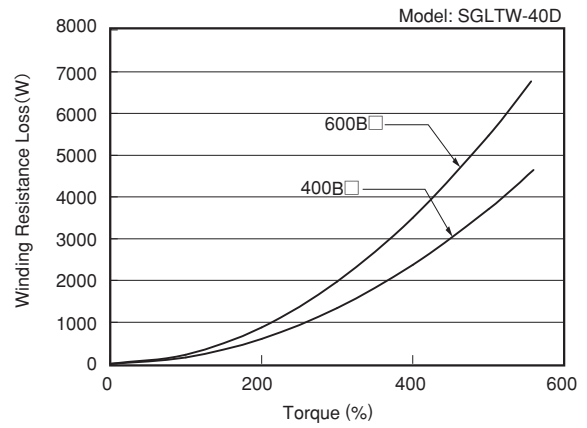
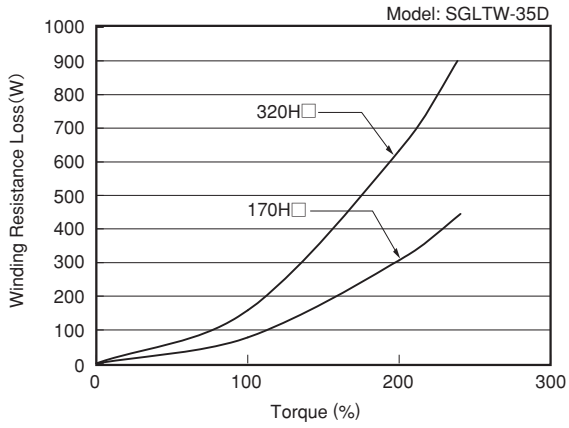

(j) SGLC Cylinder Type Linear Servomotors

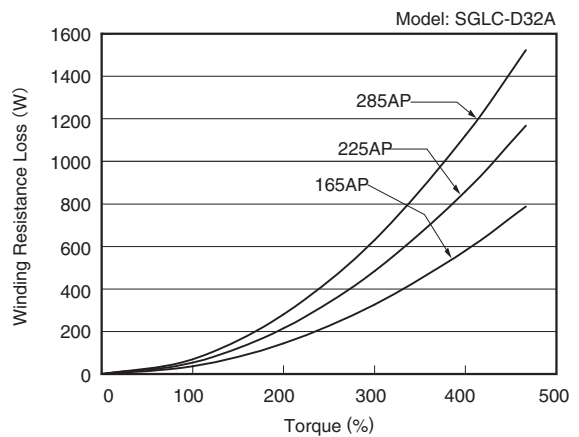
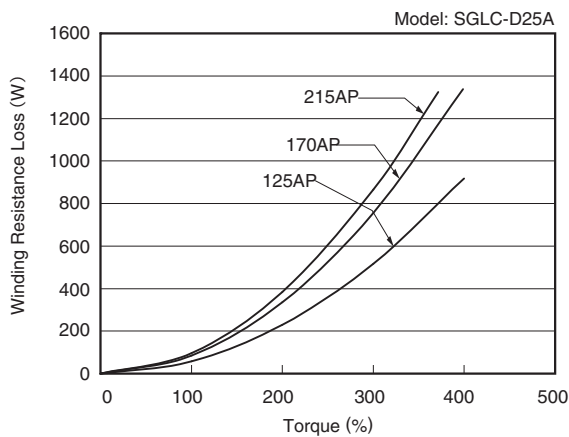
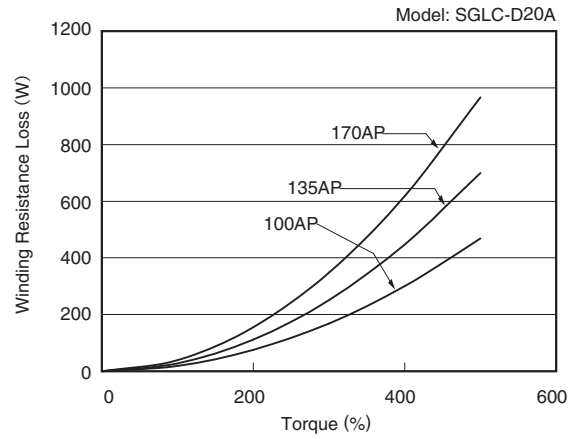
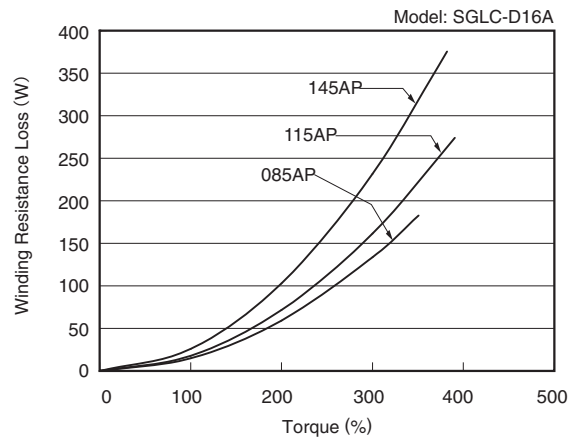

Selecting Regenerative Resistors

(k) SGT Linear Sliders

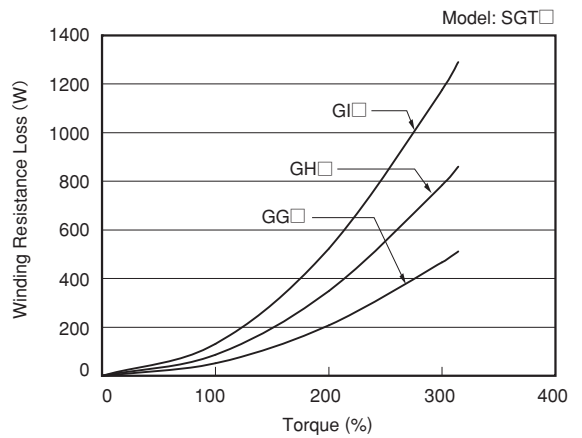
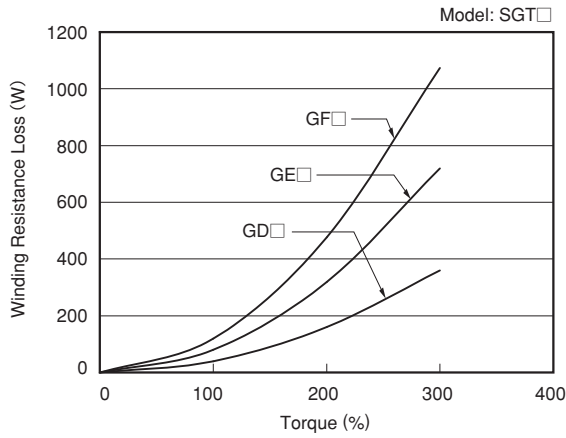
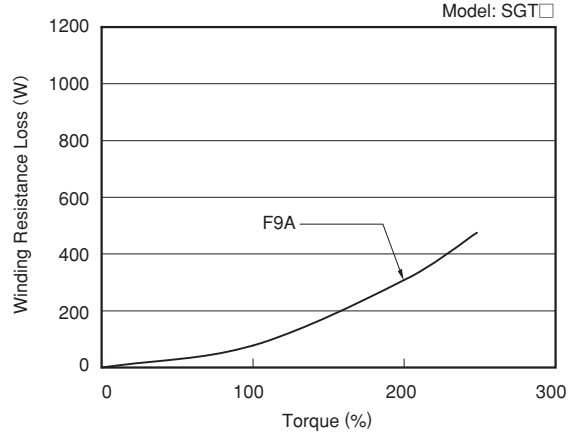
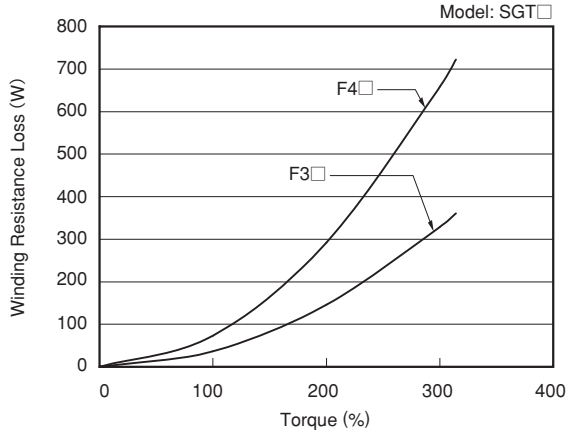



Connection to Host Controller

Example of Connection to Machine Controller MP2□□□

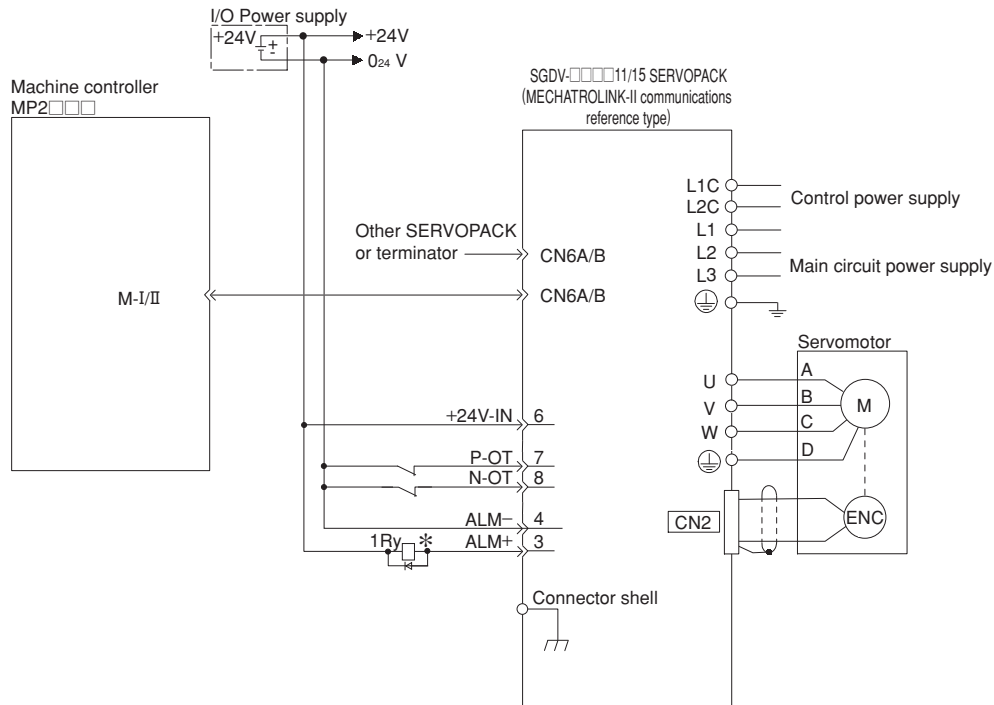

*: The ALM signal is output for five seconds or less when the power is turned ON. Take this into consideration when designing the power ON sequence. The ALM signal actuates the alarm detection relay "1Ry" to stop the main circuit power supply to the SERVOPACK.

- Notes: 1 Only signals applicable to Machine Controller MP2□□□ and Yaskawa's SGD□ SERVOPACK are shown in the diagram.
 2 The main circuit power supply is a three-phase 200 VAC SERVOPACK input in the example.
 3 Note that incorrect connection will cause damage to the Machine Controller and SERVOPACK. Take particular care to wire correctly.
 4 Open the signal lines not to be used.
 5 The above connection diagram shows only X-axis connection. When using another axes, make connection to the SERVOPACK in the same way.
 6 The normally closed (N.C.) input terminals not to be used at the Machine Controller I/O connector section must be short-circuited at the connector.
 7 The SERVOPACK has a built-in safety function to protect prevent anyone in the vicinity from being injured by unexpected motion. But, in order to use the function, the circuit for CN8 is required to be configured. When not using the function, use SERVOPACKs with the Safety Jumper Connector connected.

Example of Connection to MP2200 / MP2300 Motion Module SVA-01

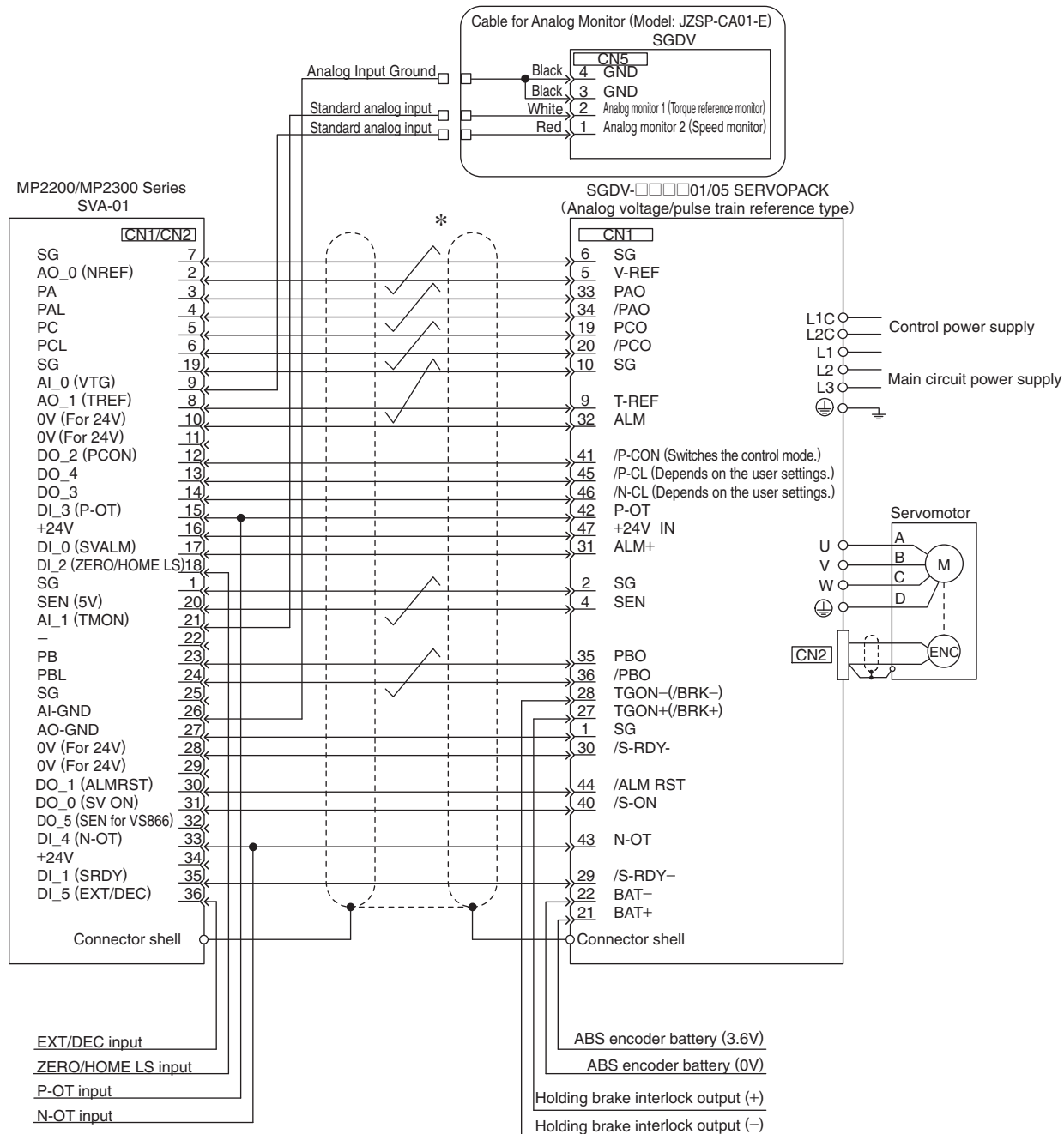

*: represents shielded twisted-pair wires.

- Notes:
- 1 Connection cables (model: JEPMC-W 2040-□□) to connect the SERVOPACK to the MP2200/MP2300 are provided by Yaskawa. For details, see "Machine Controller MP2200/MP2300 Motion Module User's Manual" (manual no. SIEP C880700 16).
 - 2 Only signals applicable to MP2200 / MP2300 Motion Module SVA-01 and Yaskawa's SGDV SERVOPACK are shown in the diagram.
 - 3 The main circuit power supply is a three-phase 200 VAC SERVOPACK input in the example.
 - 4 Note that incorrect connection will cause damage to the Machine Controller and SERVOPACK. Take particular care to wire correctly.
 - 5 Open the signal lines not to be used.
 - 6 The above connection diagram shows only X-axis connection. When using another axes, make connection to the SERVOPACK in the same way.
 - 7 The normally closed (N.C.) input terminals not to be used at the Machine Controller I/O connector section must be short-circuited at the connector.
 - 8 Make the setting so that the servo can be turned ON/OFF by the /S-ON signal.
 - 9 The SERVOPACK has a built-in safety function to protect prevent anyone in the vicinity from being injured by unexpected motion. But, in order to use the function, the circuit for CN8 is required to be configured. When not using the function, use SERVOPACKS with the Safety Jumper Connector connected.

Example of Connection to MP920 4-axes Analog Module SVA-01

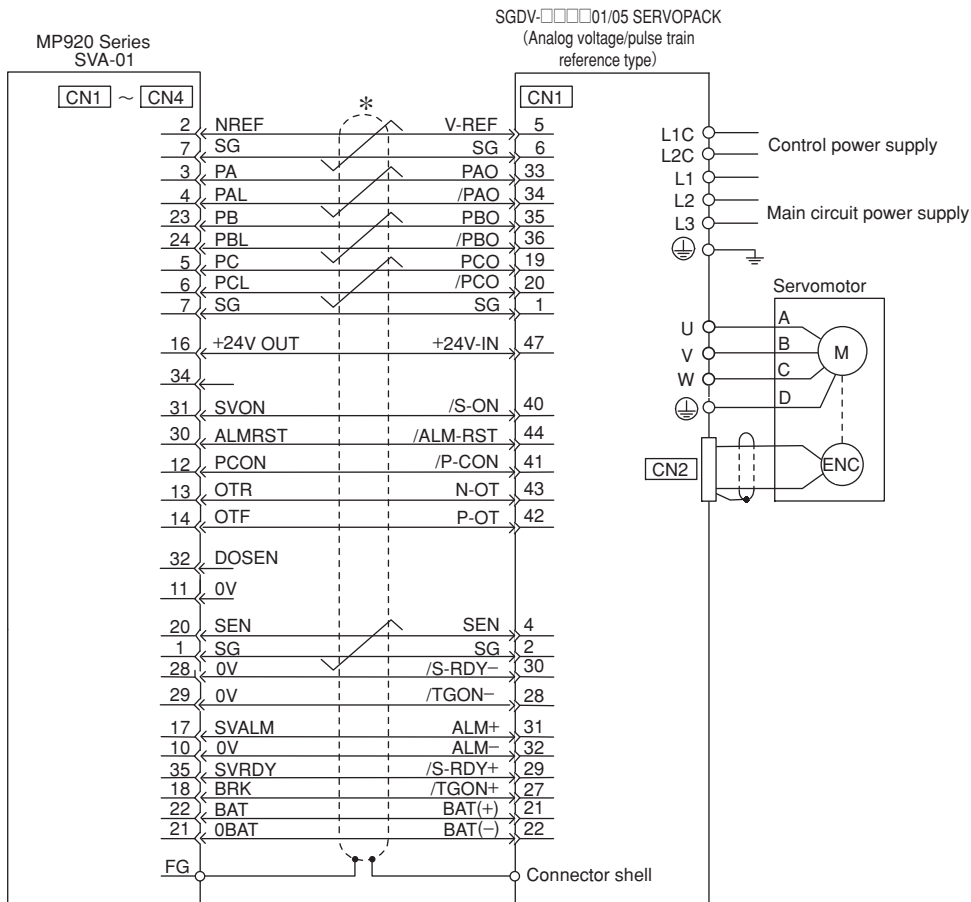

*: represents shielded twisted-pair wires.

- Notes:
- 1 Connection cables (model: JEPMC-W6050-□□) to connect the SERVOPACK to the MP920 are provided by Yaskawa. For details, see "Machine Controller MP920 User's Manual Design and Maintenance" (manual no. SIEZ-C887-2.1).
 - 2 Only signals applicable to MP920 4-axes Analog Module SVA-01 and Yaskawa's SGD Servopack are shown in the diagram.
 - 3 The main circuit power supply is a three-phase 200 VAC SERVOPACK input in the example.
 - 4 Note that incorrect connection will cause damage to the Machine Controller and SERVOPACK. Take particular care to wire correctly.
 - 5 Open the signal lines not to be used.
 - 6 The above connection diagram shows only X-axis connection. When using another axes, make connection to the SERVOPACK in the same way.
 - 7 The normally closed (N.C.) input terminals not to be used at the Machine Controller I/O connector section must be short-circuited at the connector.
 - 8 Make the setting so that the servo can be turned ON/OFF by the /S-ON signal.
 - 9 The SERVOPACK has a built-in safety function to protect prevent anyone in the vicinity from being injured by unexpected motion. But, in order to use the function, the circuit for CN8 is required to be configured. When not using the function, use SERVOPACKs with the Safety Jumper Connector connected.

Example of Connection to OMRON's Motion Control Unit

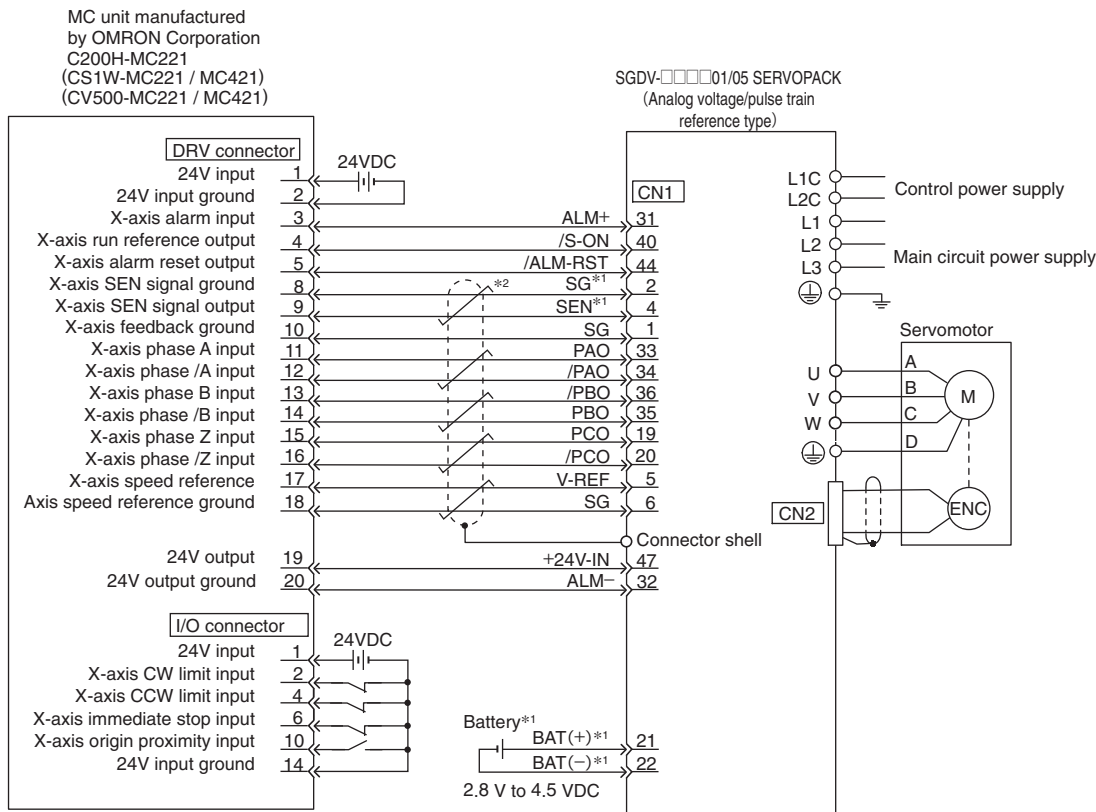

*1: Use a battery when using an absolute encoder.

No battery is needed for CN1 (between 21, 22) when using an encoder cable with a battery.

- Battery for CN1 : ER6VC3N (3.6 V, 2000 mA)
- Battery for battery unit : JZSP-BA01 (3.6 V, 1000 mA)

*2:  represents shielded twisted-pair wires.

Notes: 1 Only signals applicable to OMRON Corporation's MC unit and Yaskawa's SGDV SERVOPACK are shown in the diagram.

2 The main circuit power supply is a three-phase 200 VAC SERVOPACK input in the example.

3 Note that incorrect connection will cause damage to the MC unit and SERVOPACK.

Take particular care to wire correctly.

4 Open the signal lines not to be used.

5 The above connection diagram shows only X-axis connection. When using another axes, make connection to the SERVOPACK in the same way.

6 The normally closed (N.C.) input terminals not to be used at the motion control unit I/O connector section must be short-circuited at the connector.

7 Make the setting so that the servo can be turned ON/OFF by the /S-ON signal.

8 The SERVOPACK has a built-in safety function to prevent anyone in the vicinity from being injured by unexpected motion. But, in order to use the function, the circuit for CN8 is required to be configured. When not using the function, use SERVOPACKs with the Safety Jumper Connector connected.

Example of Connection to OMRON's Position Control Unit

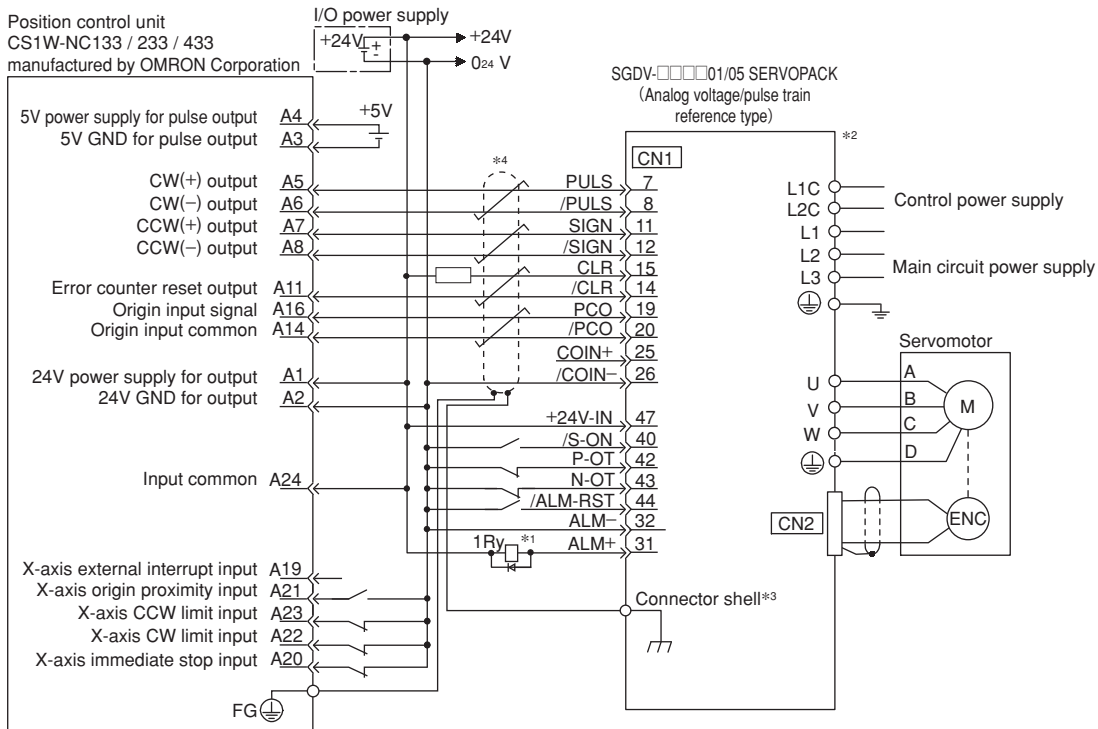

*1: The ALM signal is output for five seconds or less when the power is turned ON. Take this into consideration when designing the power ON sequence. The ALM signal actuates the alarm detection relay "1Ry" to stop the main circuit power supply to the SERVOPACK.

*2: Set parameter Pn200.0 = 1 or 6.

*3: Connect the shield wire to the connector shell.

*4:  represents shielded twisted-pair wires.

- Notes: 1 Only signals applicable to OMRON Corporation's position control unit and Yaskawa's SGDV SERVOPACK are shown in the diagram.
 2 The main circuit power supply is a three-phase 200 VAC SERVOPACK input in the example.
 3 Note that incorrect connection will cause damage to the position control unit and SERVOPACK. Take particular care to wire correctly.
 4 Open the signal lines not to be used.
 5 The above connection diagram shows only X-axis connection. When using another axes, make connection to the SERVOPACK in the same way.
 6 The normally closed (N.C.) input terminals not to be used at the position control unit I/O connector section must be short-circuited at the connector.
 7 Make the setting so that the servo can be turned ON/OFF by the /S-ON signal.
 8 The SERVOPACK has a built-in safety function to prevent anyone in the vicinity from being injured by unexpected motion. But, in order to use the function, the circuit for CN8 is required to be configured. When not using the function, use SERVOPACKs with the Safety Jumper Connector connected.

Example of Connection to Mitsubishi's AD72 Positioning Unit (SERVOPACK in Speed Control)

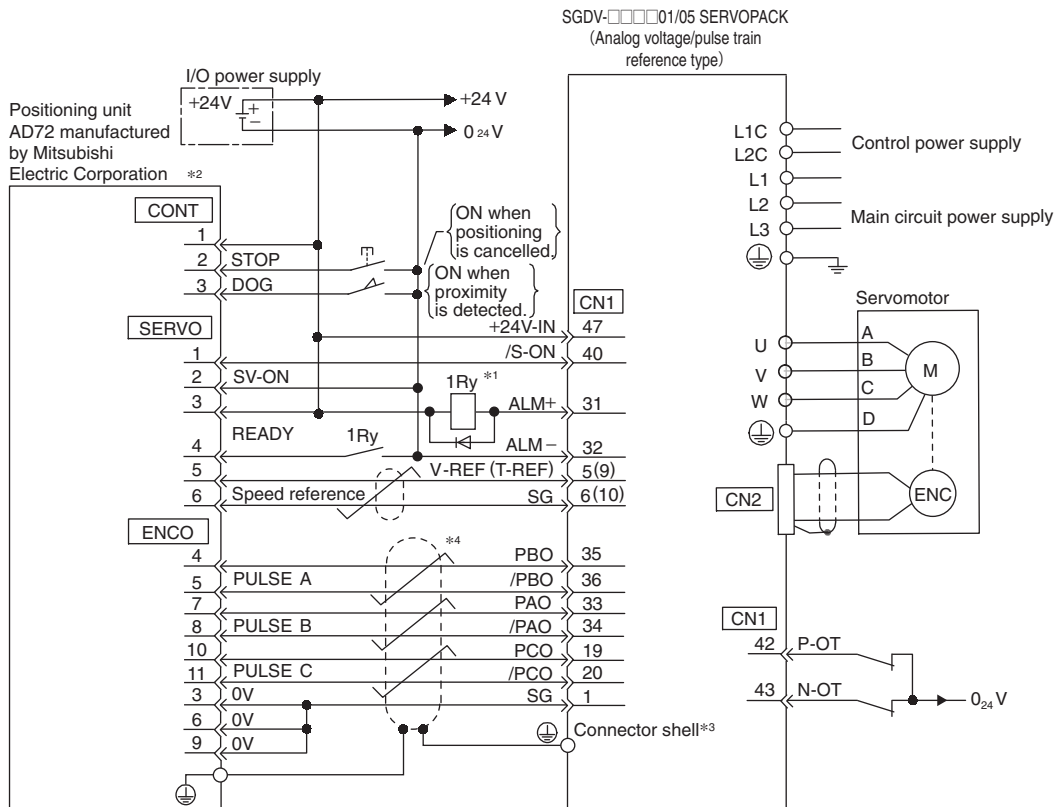

*1: The ALM signal is output for five seconds or less when the power is turned ON. Take this into consideration when designing the power ON sequence. The ALM signal actuates the alarm detection relay "1Ry" to stop the main circuit power supply to the SERVOPACK.

*2: Pin numbers are the same both for X-axis and Y-axis.

*3: Connect the shield wire to the connector shell.

*4:  represents shielded twisted-pair wires.

Notes: 1 Only signals applicable to Mitsubishi Electric Corporation's AD72 positioning unit and Yaskawa's SGDV SERVOPACK are shown in the diagram.

2 The main circuit power supply is a three-phase 200 VAC SERVOPACK input in the example.

3 Note that incorrect connection will cause damage to the positioning unit and SERVOPACK. Take particular care to wire correctly.

4 Open the signal lines not to be used.

5 The above connection diagram shows only X-axis connection. When using another axes, make connection to the SERVOPACK in the same way.

6 The normally closed (N.C.) input terminals not to be used at the positioning unit I/O connector section must be short-circuited at the connector.

7 Make the setting so that the servo can be turned ON/OFF by the /S-ON signal.

8 The SERVOPACK has a built-in safety function to prevent anyone in the vicinity from being injured by unexpected motion. But, in order to use the function, the circuit for CN8 is required to be configured. When not using the function, use SERVOPACKs with the Safety Jumper Connector connected.

Example of Connection to Mitsubishi's AD75 Positioning Unit (SERVOPACK in Position Control)

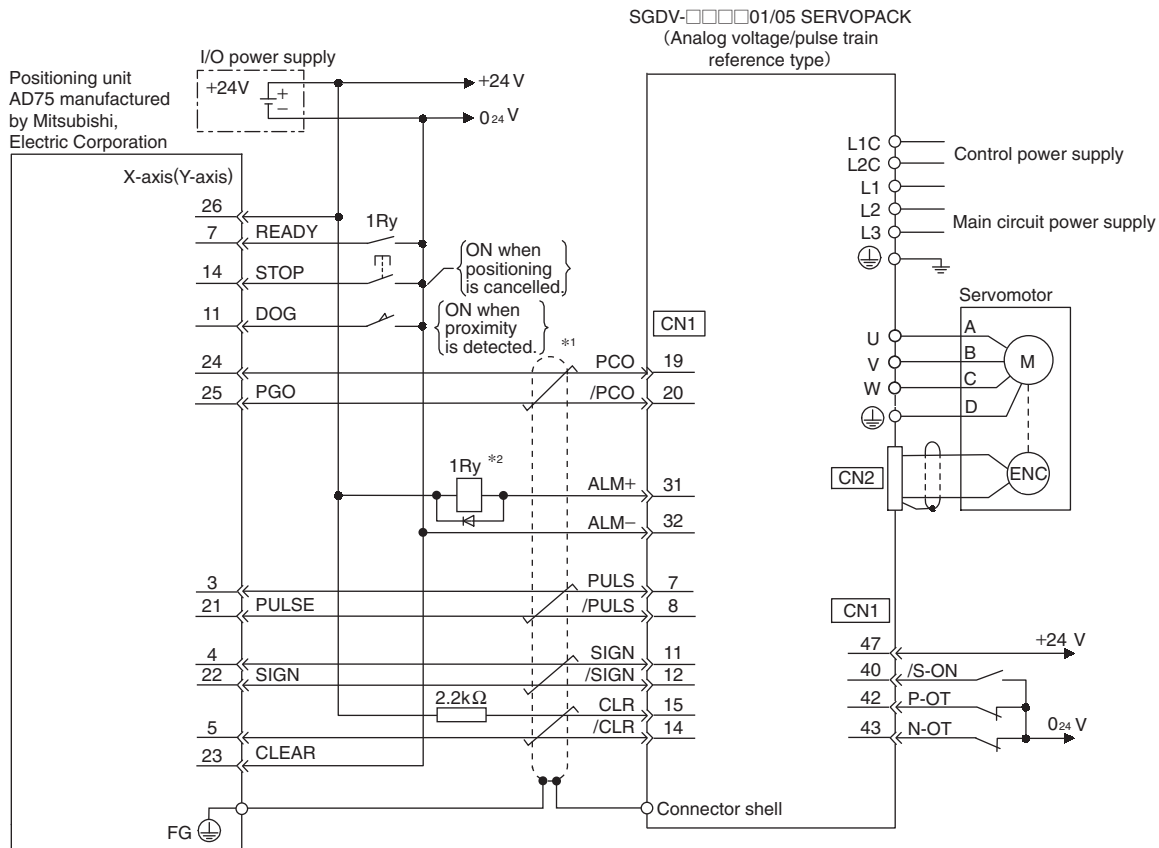

*1: represents shielded twisted-pair wires.

*2: The ALM signal is output for five seconds or less when the power is turned ON. Take this into consideration when designing the power ON sequence. The ALM signal actuates the alarm detection relay "1Ry" to stop the main circuit power supply to the SERVOPACK.

Notes: 1 Only signals applicable to Mitsubishi Electric Corporation's AD75 positioning unit and Yaskawa's SGDV SERVOPACK are shown in the diagram.

2 The main circuit power supply is a three-phase 200 VAC SERVOPACK input in the example.

3 Note that incorrect connection will cause damage to the positioning unit and SERVOPACK. Take particular care to wire correctly.

4 Open the signal lines not to be used.

5 The above connection diagram shows only X-axis connection. When using another axes, make connection to the SERVOPACK in the same way.

6 The normally closed (N.C.) input terminals not to be used at the positioning unit I/O connector section must be short-circuited at the connector.

7 Make the setting so that the servo can be turned ON/OFF by the /S-ON signal.

8 The SERVOPACK has a built-in safety function to prevent anyone in the vicinity from being injured by unexpected motion. But, in order to use the function, the circuit for CN8 is required to be configured. When not using the function, use SERVOPACKs with the Safety Jumper Connector connected.

Example of Connection to Mitsubishi's QD75D Positioning Unit (SERVOPACK in Position Control)

Positioning unit
QD75D manufactured
by Mitsubishi
Electric Corporation

SGDV-000001/05 SERVOPACK
(Analog voltage/pulse train
reference type)

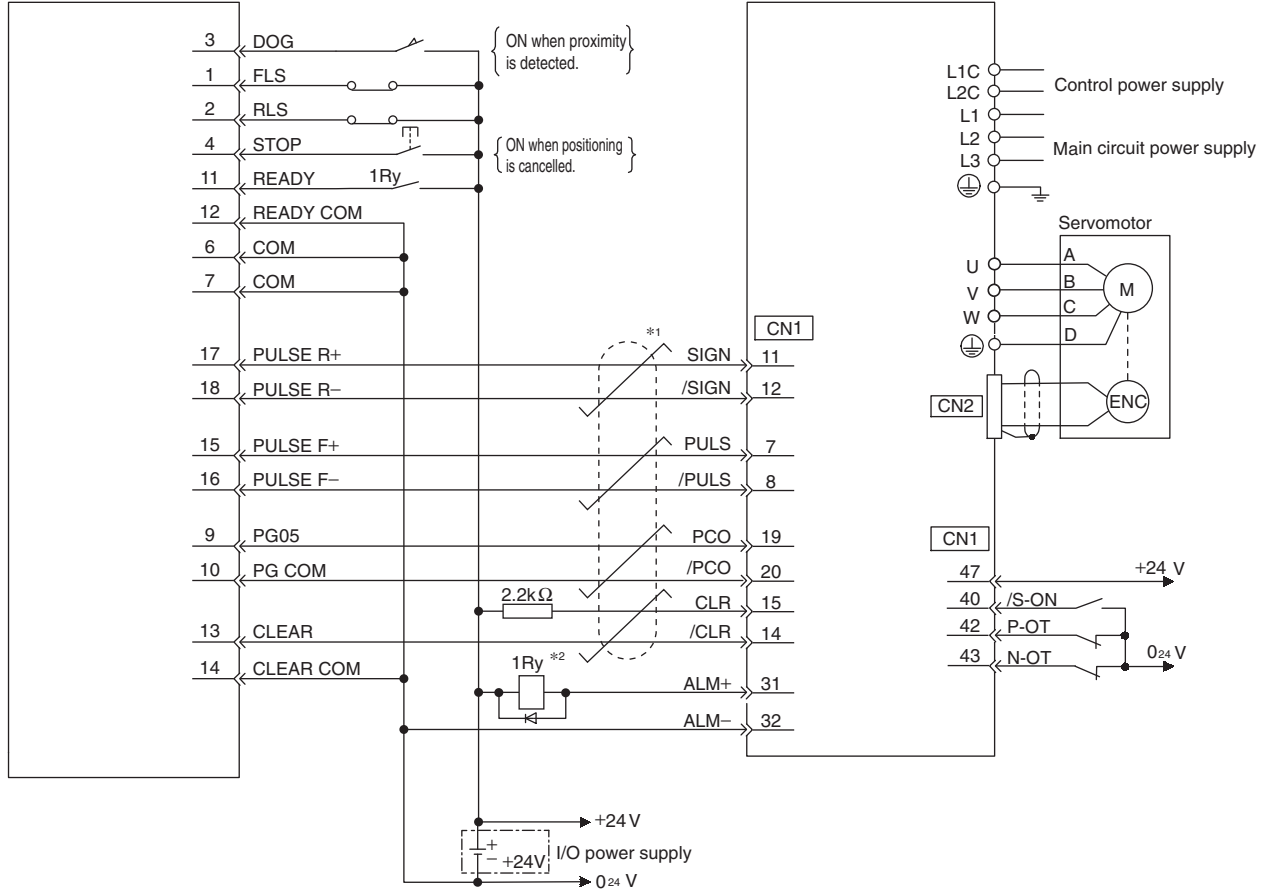

*1: represents shielded twisted-pair wires.

*2: The ALM signal is output for five seconds or less when the power is turned ON. Take this into consideration when designing the power ON sequence. The ALM signal actuates the alarm detection relay "1Ry" to stop the main circuit power supply to the SERVOPACK.

Notes: 1 Only signals applicable to Mitsubishi Electric Corporation's QD75D positioning unit and Yaskawa's SGDV SERVOPACK are shown in the diagram.

2 The main circuit power supply is a three-phase 200 VAC SERVOPACK input in the example.

3 Note that incorrect connection will cause damage to the positioning unit and SERVOPACK. Take particular care to wire correctly.

4 Open the signal lines not to be used.

5 The above connection diagram shows only X-axis connection. When using another axes, make connection to the SERVOPACK in the same way.

6 The normally closed (N.C.) input terminals not to be used at the positioning unit I/O connector section must be short-circuited at the connector.

7 Make the setting so that the servo can be turned ON/OFF by the /S-ON signal.

8 The SERVOPACK has a built-in safety function to prevent anyone in the vicinity from being injured by unexpected motion. But, in order to use the function, the circuit for CN8 is required to be configured. When not using the function, use SERVOPACKs with the Safety Jumper Connector connected.



Read Before Ordering

1. Product Warranty

During the warranty period, Yaskawa shall repair free of charge any defects attributable to Yaskawa that may occur in a product that was purchased (hereafter “delivered product”).

1) Scope of Warranty

Yaskawa shall replace or repair a defective product free of charge if a defect attributable to Yaskawa occurs during the period of warranty given in item 2 below. This warranty is limited to the product alone. Any damage or loss of opportunity arising from malfunction or defect in the product are outside the scope of this warranty. Defects due to the delivered product reaching the end of its service life and replacement of parts that require replacement or that have a limited service life are also outside the scope of this warranty.

2) Period of Warranty

The period of warranty for the delivered product is one year from the time of delivery to the location specified by the customer or 18 months from the time of shipment from the Yaskawa factory, whichever is sooner.

3) Limitations of Liability

Failures that occur for any of the following causes are outside the scope of the warranty.

- ① Using or handling the product under conditions or in environments not described in this catalog, the manuals of the delivered product, or separately agreed-upon specifications
- ② Causes not attributable to the product itself
- ③ Modifications or repairs not performed by Yaskawa
- ④ Using the product in a manner in which it was not originally intended
- ⑤ Causes that were not foreseeable with the scientific and technological understanding at the time of shipment from Yaskawa
- ⑥ Events for which Yaskawa is not responsible, such as natural or human-made disasters

2. Limitations of Liability

- ① Yaskawa shall in no event be responsible for any damage or loss of opportunity to the customer that arises due to failure of the delivered product.
- ② Yaskawa shall not be responsible for programming (including parameter settings) or the results of program execution if a programmable Yaskawa product was programmed by the user or by a third party.

3. Suitability for Use

- ① It is the customer's responsibility to confirm conformity with any standards, codes, or regulations that apply if the Yaskawa product is used in combination with any other products.
- ② The customer must confirm that the Yaskawa product is suitable for the systems, machines, and equipment used by the customer.
- ③ Consult with Yaskawa to determine whether use in the following applications is acceptable. If use in the application is acceptable, use the product with extra allowance in ratings and specifications, and provide safety measures to minimize hazards in the event of failure.
 - Outdoor use, use involving potential chemical contamination or electrical interference, or use in conditions or environments not described in this catalog
 - Nuclear energy control systems, combustion systems, railroad systems, aviation systems, vehicle systems, medical equipment, amusement machines, and installations subject to separate industry or government regulations
 - Systems, machines, and equipment that may present a risk to life or property
 - Systems that require a high degree of reliability, such as systems that supply gas, water, or electricity, or systems that operate continuously 24 hours a day
 - Other systems that require a similar high degree of safety
- ④ Never use the product for an application involving serious risk to life or property without first ensuring that the required safety has been designed into the system with risk warnings and redundancy, and that the Yaskawa product is properly rated and installed.
- ⑤ The circuit examples and other application examples described in this catalog are for reference. Check the functionality and safety of the actual devices and equipment to be used before using the product.
- ⑥ Read and understand all use prohibitions and precautions, and operate the Yaskawa product correctly to prevent accidental harm to third parties.

4. Changes to Specifications

The names, specifications, appearance, and accessories of products in this catalog may be changed at any time based on improvements and other reasons. Consult with your Yaskawa representative to confirm the actual specifications before purchasing a product.

Σ-V SERIES PRODUCT CATALOG

IRUMA BUSINESS CENTER (SOLUTION CENTER)

480, Kamifujisawa, Iruma, Saitama 358-8555, Japan
Phone 81-4-2962-5696 Fax 81-4-2962-6138

YASKAWA ELECTRIC AMERICA, INC.

2121 Norman Drive South, Waukegan, IL 60085, U.S.A.
Phone (800) YASKAWA (800-927-5292) or 1-847-887-7000 Fax 1-847-887-7370

YASKAWA ELÉTRICO DO BRASIL LTDA.

Avenida Fagundes Filho, 620 São Paulo-SP CEP 04304-000, Brazil
Phone 55-11-3585-1100 Fax 55-11-5581-8795

YASKAWA ELECTRIC EUROPE GmbH

Hauptstraße 185, 65760 Eschborn, Germany
Phone 49-6196-569-300 Fax 49-6196-569-398

YASKAWA ELECTRIC UK LTD.

1 Hunt Hill Orchardton Woods Cumbernauld, G68 9LF, United Kingdom
Phone 44-1236-735000 Fax 44-1236-458182

YASKAWA ELECTRIC KOREA CORPORATION

7F, Doore Bldg. 24, Yeoido-dong, Youngdungpo-Ku, Seoul 150-877, Korea
Phone 82-2-784-7844 Fax 82-2-784-8495

YASKAWA ELECTRIC (SINGAPORE) PTE. LTD.

151 Lorong Chuan, #04-01, New Tech Park 556741, Singapore
Phone 65-6282-3003 Fax 65-6289-3003

YASKAWA ELECTRIC (SHANGHAI) CO., LTD.

No.18 Xizang Zhong Road, Room 1702-1707, Harbour Ring Plaza Shanghai 200001, China
Phone 86-21-5385-2200 Fax 86-21-5385-3299

YASKAWA ELECTRIC (SHANGHAI) CO., LTD. BEIJING OFFICE

Room 1011A, Tower W3 Oriental Plaza, No.1 East Chang An Ave.,
Dong Cheng District, Beijing 100738, China
Phone 86-10-8518-4086 Fax 86-10-8518-4082

YASKAWA ELECTRIC TAIWAN CORPORATION

9F, 16, Nanking E. Rd., Sec. 3, Taipei, Taiwan
Phone 886-2-2502-5003 Fax 886-2-2505-1280



YASKAWA

YASKAWA ELECTRIC CORPORATION

In the event that the end user of this product is to be the military and said product is to be employed in any weapons systems or the manufacture thereof, the export will fall under the relevant regulations as stipulated in the Foreign Exchange and Foreign Trade Regulations. Therefore, be sure to follow all procedures and submit all relevant documentation according to any and all rules, regulations and laws that may apply. Specifications are subject to change without notice for ongoing product modifications and improvements.

© 2007-2009 YASKAWA ELECTRIC CORPORATION. All rights reserved.

LITERATURE NO. KAEP S800000 42E

Published in Japan May 2009 07-6 09-1