

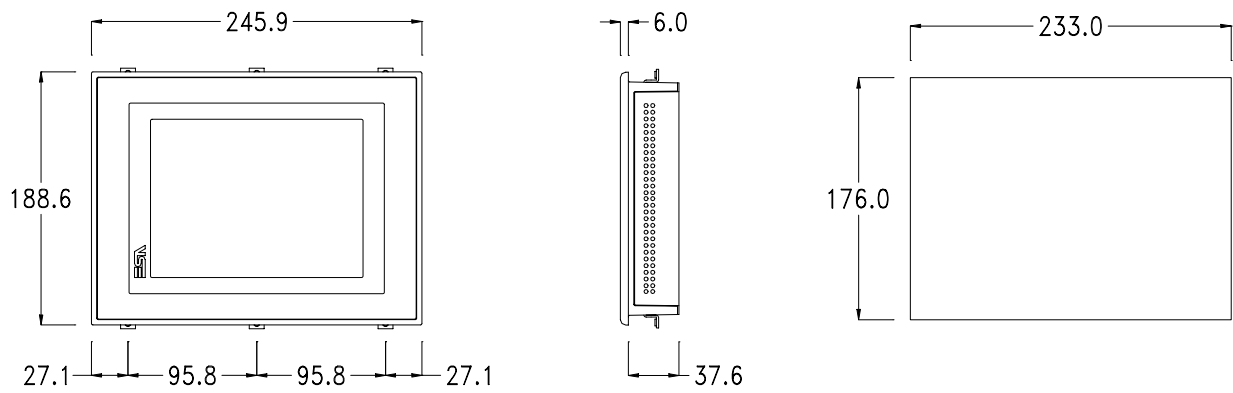

VT TERMINALI OPERATORE UNIVERSALI
VT UNIVERSAL OPERATOR TERMINALS
VT TERMINAUX OPERATEURS UNIVERSELS
VT UNIVERSELLE BEDIENTERMINALS
VT TERMINALES DE OPERADOR UNIVERSALES

**Dimensioni - Forature / Dimensions - Holes / Dimensions - Trous /
Abmessungen - Bohrungen / Dimensiones y perforaciones**

VT575W



VT580W

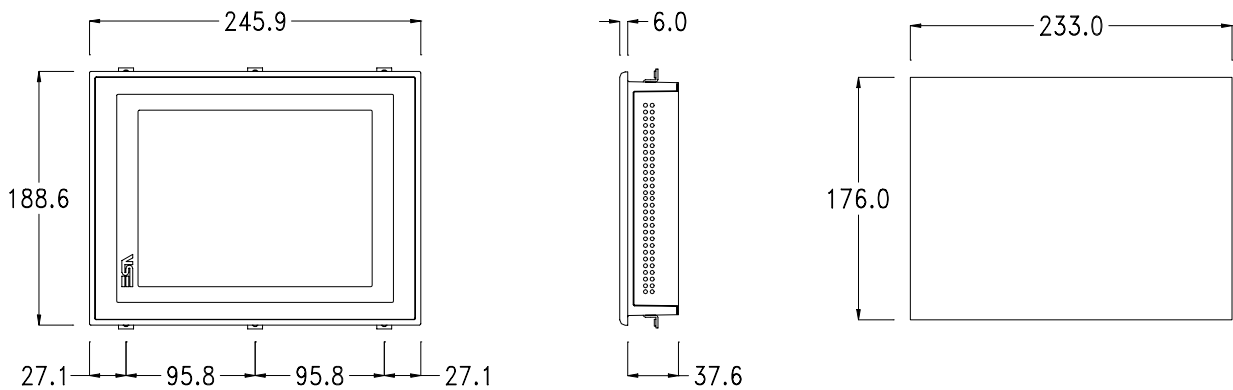

VT575W/VT580W

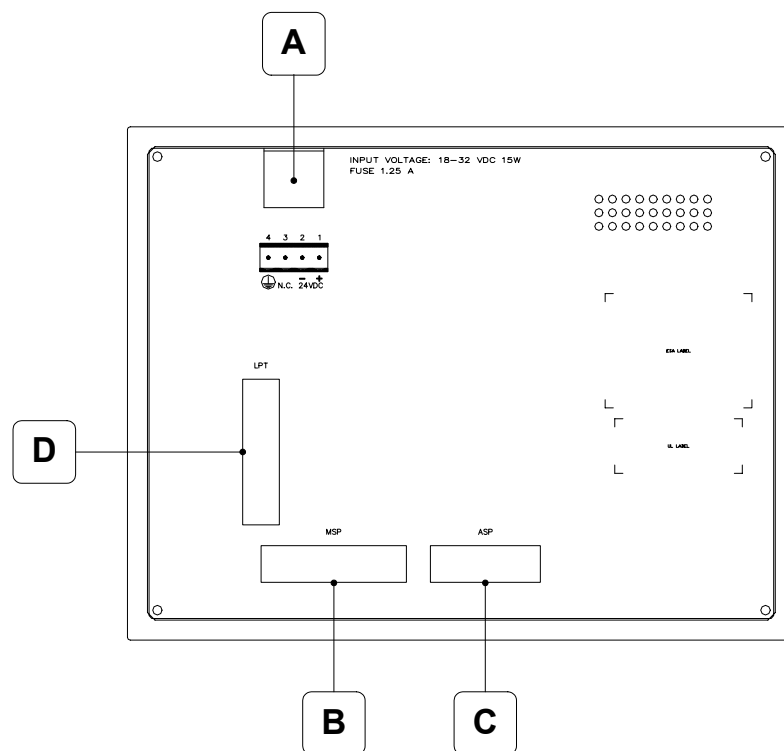

<p>A Connettore di alimentazione. Power supply connector. Connecteur d'alimentation. Anschluß für die Spannungsversorgung. Conector de alimentación.</p>	<p>C ASP Porta seriale per la comunicazione con PC o altri dispositivi. Serial port for communicating with PC or other devices. Port sériel pour la communication avec le PC ou autre dispositif. Serielle Schnittstelle für die Kommunikation mit PC oder mit anders Gerät. Puerto serie para la comunicación con PC o otro aparatos.</p>
<p>B MSP Porta seriale per la comunicazione con PLC/PC. Serial port for communicating with PLC/PC. Port sériel pour la communication avec le PLC/PC. Serielle Schnittstelle für die Kommunikation mit SPS/PC. Puerto serie para la comunicación con PLC/PC.</p>	<p>D LPT Porta parallela. Parallel port. Port parallèle. Paralleler Port. Puerto paralelo.</p>

Inserimento guarnizione di protezione e installazione VT / Attaching protective gasket and installing the VT / L'insertion du bourrelet isolant et l'installation du VT / Einfügung der Schutzdichtung und VT-Installation / Introducción de la guarnición de protección e instalación del VT

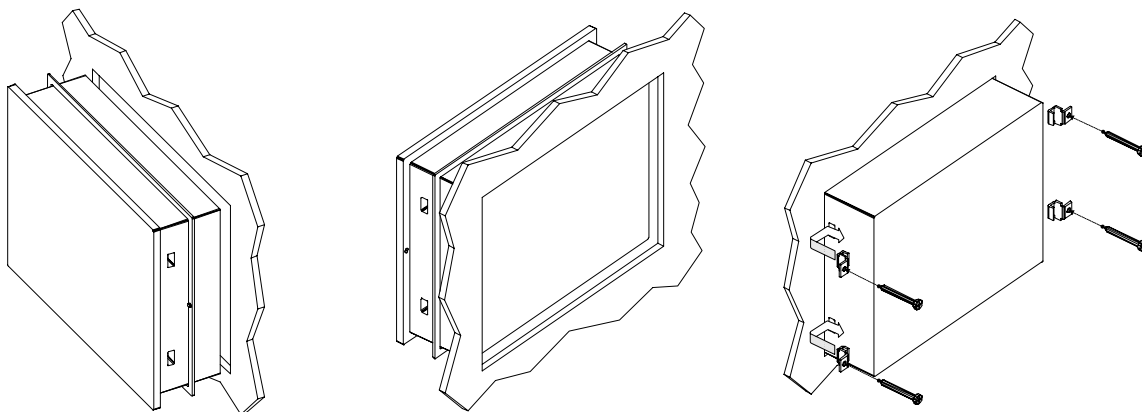

**Calibrazione Touch Screen / Touch screen calibration / Calibrage Écran Tactile /
Kalibrierung Touch Screens / Calibración Pantalla Táctil**

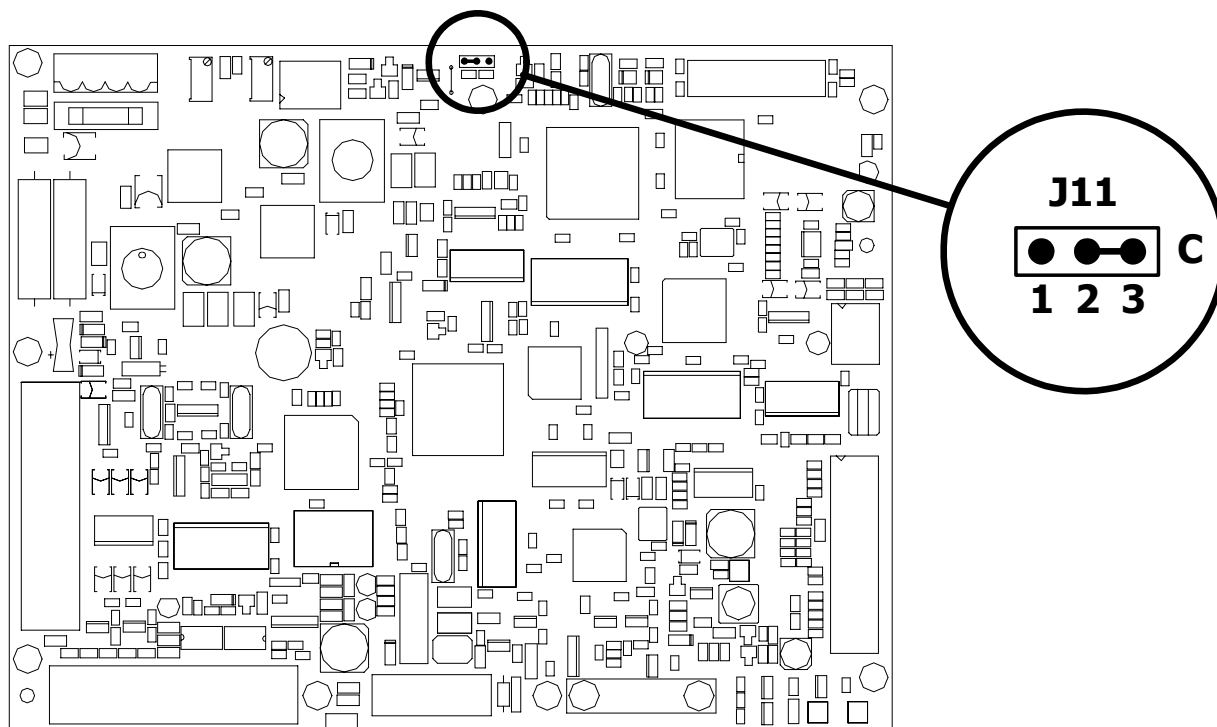

<p>Calibrazione OFF (default) / Calibration OFF (default) / Calibrage OFF (défaut) / Kalibrierung OFF (default) / Calibración OFF (default)</p>	<p>Calibrazione ON / Calibration ON / Calibrage ON / Kalibrierung ON / Calibración ON</p>
<p>J11 pin 1-2</p>	<p>J11 pin 2-3</p>

Calibrazione Touch Screen / Touch screen calibration / Calibrage Écran Tactile / Kalibrierung Touch Screens / Calibración Pantalla Táctil

Il terminale viene fornito con il touch screen già calibrato. Nel caso il touch screen perda la calibrazione (vedi anche Manuale Hardware Rel. 2.12 o superiore): / The terminal is supplied with its touch screen already calibrated. If the touch screen loses its calibration (see Hardware Manual Rel. 2.12 or later) carry out the following steps: / Le terminal est fourni avec l'écran tactile déjà calibré. Dans le cas où l'écran tactile perdrait son calibrage (voir également Manuel Hardware Ver. 2.12 ou supérieure): / Das Terminal wird mit bereits kalibriertem Touch Screen geliefert. Im Falle, dass der er die Kalibrierung verliert (siehe auch Hardware-Handbuch, Version. 2.12 oder später): / La pantalla táctil suministrada ya está calibrada. Cuando el terminal con pantalla táctil pierda la calibración (ver también Manual Hardware Rel. 2.12 o sucesivo):

1. Spegner il VT / Switch off VT / Éteindre le VT / Das VT ausschalten / Apague el VT
2. Rimuovere la copertura / Remove back cover / Enlever le couvercle / Das Gehäuse abnehmen / Quite la cubierta
3. Identificare J11 / Locate J11 / Identifier J11 / J11 ausfindig machen / Localice J11
4. Spostare il ponticello sui pin 2-3 / Move the jumper to pins 2-3 / Déplacer le shunt sur les pin 2-3 / Die Brücke auf Pins 2-3 setzen / Ponga el puente en los pin 2-3
5. Riaccendere il VT / Switch VT on again / Réallumer le VT / Das VT wieder einschalten / Vuelva a encender el VT
6. Calibrare seguendo le istruzioni a video / Calibrate following the instructions on-screen / Calibrer selon les instructions données sur l'écran / Die Kalibrierung den Anweisungen am Bildschirm entsprechend vornehmen / Calibre siguiendo las instrucciones visualizadas
7. Attendere il completo avviamento del VT / Wait for the start-up of the VT to be completed / Attendre le démarrage complet du VT / Das Starten des VTs vollständig durchführen lassen / Espere el encendido completo del VT
8. Spegner il VT / Switch off VT / Éteindre le VT / Das VT ausschalten / Apague el VT
9. Rimettere J11 sui pin 1-2 / Reset J11 to pins 1-2 / Remettre J11 sur les pin 1-2 / J11 erneut auf Pins 1-2 setzen / Ponga J11 en los pin 1-2
10. Rimontare la copertura / Replace back cover / Remonter le couvercle / Das Gehäuse wieder aufsetzen / Vuelva a montar la cubierta
11. Riavviare il VT / Re-start VT / Remettre en fonction le VT / Das VT erneut starten / Vuelva a encender el VT

Alimentazione / Power supply / Alimentation / Spannungsversorgung / Alimentación

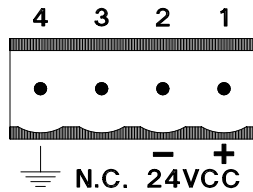

Power supply 4 pins connector	
1	+L 24 VDC
2	M 0 V
3	Not connected
4	PE Protective ground

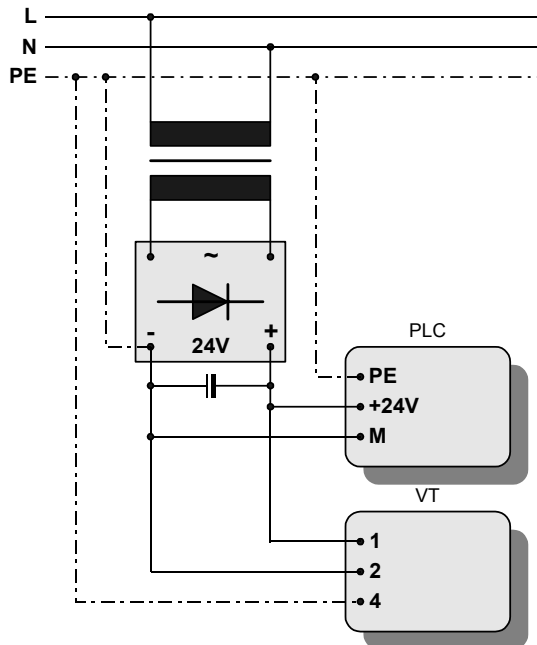

Attenzione: Queste due configurazioni danneggiano gravemente il VT.

Warning: These two configuration will seriously damage components.

Attention: Ces deux configurations peuvent endommager certains composants.

Warnung: Diese beiden Anschlussarten führen zu Schäden am VT Gerät.

Atencion: Las dos configuraciones de arriba dañan gravemente el VT.

IMPORTANTE

La massa dei dispositivi collegati alle porte di comunicazione seriali e/o parallele deve essere tassativamente allo stesso potenziale dello 0V di alimentazione del VT. La circolazione di una corrente tra lo 0V di alimentazione e la massa delle porte di comunicazione potrebbe causare il danneggiamento di alcuni componenti del VT o dei dispositivi ad esso collegati.

IMPORTANT

The earth of the devices connected to the serial and/or parallel communication ports MUST have the same potential as the 0V supply of the VT. The circulation of current between the 0V supply and the earth of the communication ports could cause damage to certain components of the VT or of the devices connected to it.

IMPORTANT

La masse des dispositifs connectés aux ports de communication parallèles ou sériels doit formellement être au même potentiel qu'il 0V d'alimentation du VT. La circulation d'un courant entre il 0V d'alimentation et la masse des ports de communication pourrait causer des dommages aux composants du VT ou des dispositifs connectés.

WICHTIG

Die Erde der Parallelen und/orer Seriellen Datenleitung müssen das gleiche Potential haben wie die Erde der Spannungsversorgung vom Bediengerät. Eine nicht korrekte Erdung der Spannungsversorgung und der Datenleitungen können schwere Schäden an den Bediengeräten sowie an den angeschlossene Komponenten hervor rufen.

ATENCION

La masa de los dispositivos conectados en los puertos de comunicación serie y/o paralelo tiene que estar conectada imprescindiblemente al mismo potencial del 0V de alimentación del VT. La circulación de una corriente entre el 0V de alimentación y la masa de los puertos de comunicación podría causar daños a algunos componentes del VT o bien a algunos dispositivos conectados.

Fusibile / Fuse / Fusible / Schmelzicherung / Fusible

1,25 A (5 x 20 mm)

Temperatura di esercizio / Working temperature / Température d'exercice / Betriebstemperatur / Temperatura de servicio

Display / Display / Afficheur / Display / Pantalla: 0 / +50°C

**Porte di comunicazione / Communication ports / Portes de communication /
Schnittstellen-Anschlüsse / Puertos de comunicación**

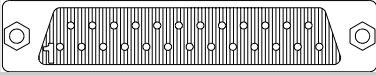
MSP	
	
Db 25 female connector	
Pin	Signal
1	N.C.
2	Tx RS232 OUT
3	Rx RS232 IN
4	RTS RS232 OUT
5	CTS RS232 IN
6	N.C.
7	Signal GND
8	N.C.
9	*Tx C.L. +OUT
10	Tx Rx485 -IN/OUT
11	*Tx C.L. -OUT
12	Tx RS422 -OUT
13	Rx RS422 + IN
14	IKT OUT
15	IKR OUT
16	+ 5 VCC (reserved)
17	N.C.
18	*Rx C.L. +IN
19	N.C.
20	N.C.
21	N.C.
22	Tx Rx485 +IN/OUT
23	Tx RS422 +OUT
24	Rx RS422 -IN
25	*Rx C.L. -IN

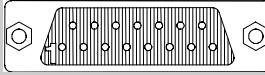
ASP	
	
Db 15 female connector	
Pin	Signal
1	DCD IN
2	RX IN
3	TX OUT
4	DTR OUT
5	Signal GND
6	N.C.
7	Signal GND
8	Tx Rx485 +IN/OUT
9	DSR IN
10	RTS OUT
11	CTS IN
12	RI IN
13	N.C.
14	N.C.
15	Tx Rx485 -IN/OUT

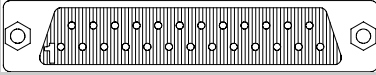
LPT	
	
Db 25 female connector	
Pin	Signal
1	Strobe
2	PRN Data 0
3	PRN Data 1
4	PRN Data 2
5	PRN Data 3
6	PRN Data 4
7	PRN Data 5
8	PRN Data 6
9	PRN Data 7
10	N.C.
11	PRN Busy
12	N.C.
13	N.C.
14	N.C.
15	N.C.
16	N.C.
17	N.C.
18	Signal GND
19	Signal GND
20	Signal GND
21	Signal GND
22	Signal GND
23	Signal GND
24	Signal GND
25	Signal GND

*C.L.: Current Loop (TTY).
N.C. : Not connected.



ESA elettronica S.p.A.
Via Padre Masciadri, 4/A
I - 22066 Mariano Comense (CO)
Tel. ++39-031757400 Fax ++39-031751777
web: <http://www.esahmi.com> e-mail: customer.care@esahmi.com