

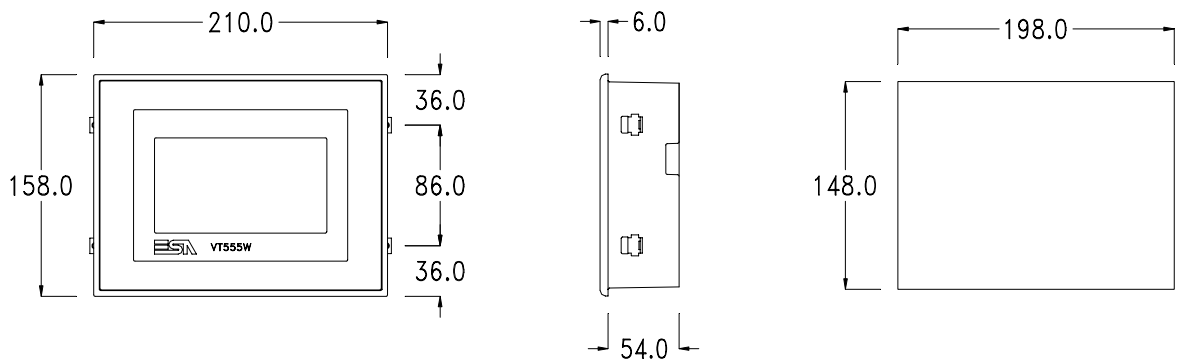

VT TERMINALI OPERATORE UNIVERSALI
VT UNIVERSAL OPERATOR TERMINALS
VT TERMINAUX OPERATEURS UNIVERSELS
VT UNIVERSELLE BEDIENTERMINALS
VT TERMINALES DE OPERADOR UNIVERSALES

**Dimensioni - Forature / Dimensions - Holes / Dimensions - Trous /
Abmessungen - Bohrungen / Dimensiones y perforaciones**

VT555W



VT560W - VT565W

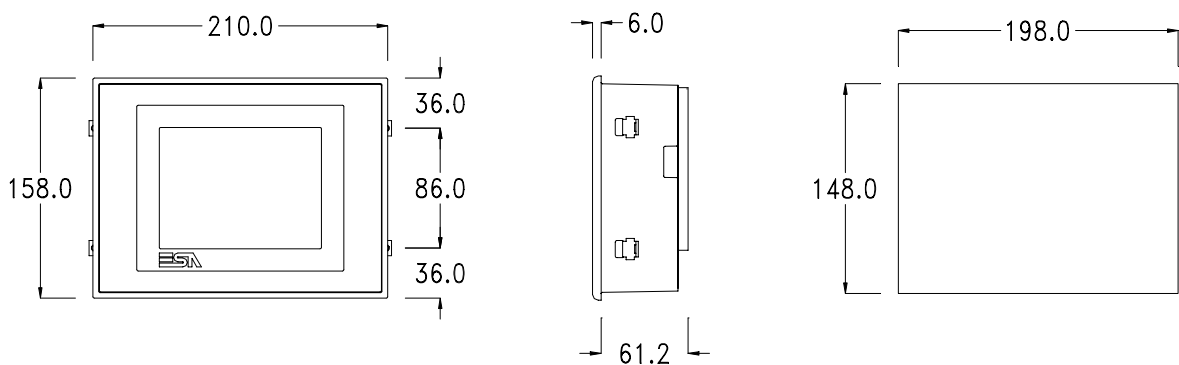

Posteriore / Rear side / Face arrières / Rückseiten / Posterior

VT555W

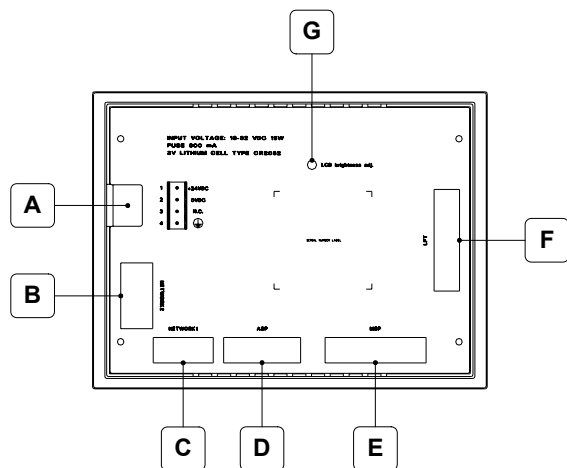

VT560W - VT565W

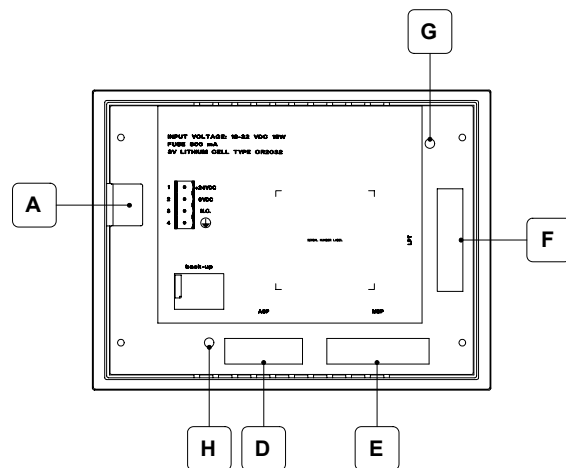

<p>A Connettore di alimentazione. Power supply connector. Connecteur d'alimentation. Anschluß für die Spannungsversorgung. Conector de alimentación.</p>	<p>E MSP Porta seriale per la comunicazione con PLC/PC. Serial port for communicating with PLC/PC. Port sériel pour la communication avec le PLC/PC. Serielle Schnittstelle für die Kommunikation mit SPS/PC. Puerto serie para la comunicación con PLC/PC.</p>
<p>B NETWORK2 (opzionale / optional / option / option / opción) Porta seriale per la comunicazione in rete. Serial port for connection in network. Porte série pour la connexion en réseau. Serielle Schnittstelle für den Anschluß an ein Netzwerk. Puerto serie para la conexión con red.</p>	<p>F LPT (opzionale / optional / option / option / opción) Porta parallela. Parallel port. Port parallèle. Paralleler Port. Puerto paralelo.</p>
<p>C NETWORK1 (opzionale / optional / option / option / opción) Porta seriale per la comunicazione in rete. Serial port for connection in network. Porte série pour la connexion en réseau. Serielle Schnittstelle für den Anschluß an ein Netzwerk. Puerto serie para la conexión con red.</p>	<p>G B&W Trimmer per regolazione della luminosità del display. Trimmer for brightness adjusting. Trimmer (potentiomètre) pour la réglage de brillance de l'affichage. Trimmer für die Helligkeitsregelung des Displays. Trimmer para la regulación de la luminosidad de la pantalla.</p>
<p>D ASP (opzionale / optional / option / option / opción) Porta seriale per la comunicazione con PC o altri dispositivi. Serial port for communicating with PC or other devices. Port sériel pour la communication avec le PC ou autre dispositif. Serielle Schnittstelle für die Kommunikation mit PC oder mit anders Gerät. Puerto serie para la comunicación con PC o otro aparatos.</p>	<p>H COLOR Trimmer per regolazione della luminosità del display. Trimmer for brightness adjusting. Trimmer (potentiomètre) pour la réglage de brillance de l'affichage. Trimmer für die Helligkeitsregelung des Displays. Trimmer para la regulación de la luminosidad de la pantalla.</p>

Inserimento guarnizione di protezione e installazione VT / Attaching protective gasket and installing the VT / L'insertion du bourrelet isolant et l'installation du VT / Einfügung der Schutzdichtung und VT-Installation / Introducción de la guarnición de protección e instalación del VT

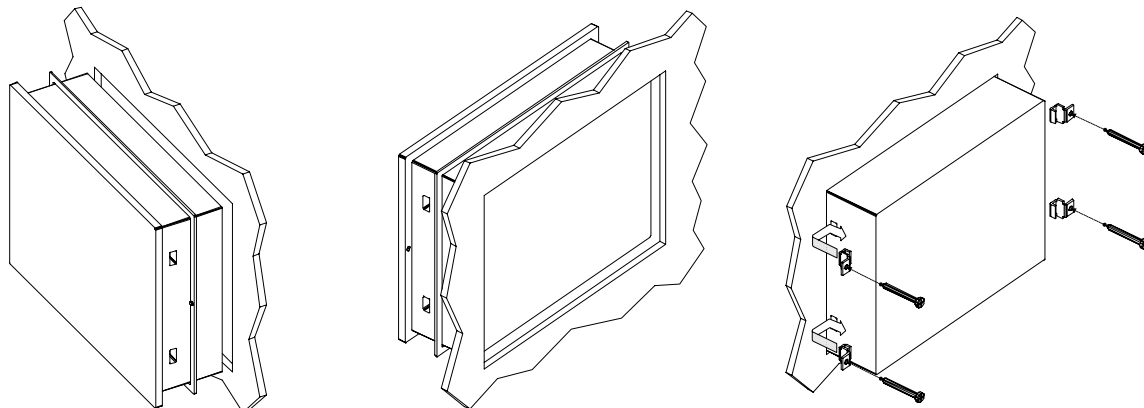

Alimentazione / Power supply / Alimentation / Spannungsversorgung / Alimentación

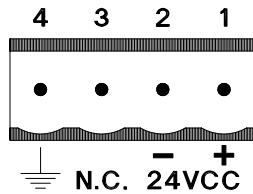

Power supply 4 pins connector	
1	+L 24 VDC
2	M 0 V
3	Not connected
4	PE Protective ground

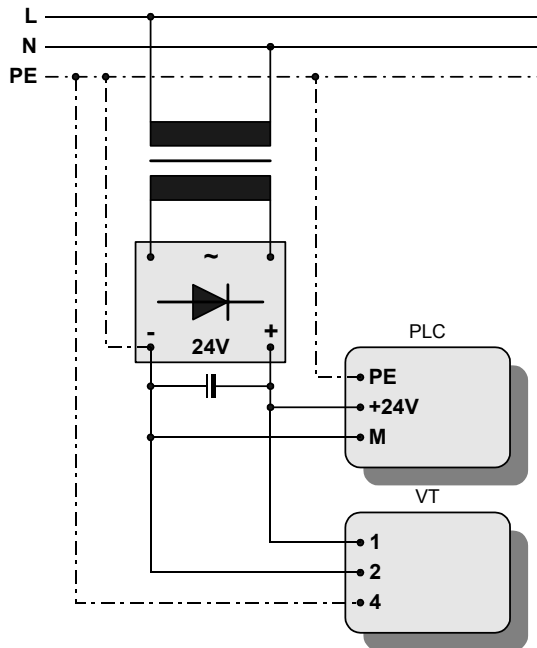

Attenzione: Queste due configurazioni danneggiano gravemente il VT.
Warning: These two configuration will seriously damage components.
Attention: Ces deux configurations peuvent endommager certains composants.
Warnung: Diese beiden Anschlussarten führen zu Schäden am VT Gerät.
Atencion: Las dos configuraciones de arriba dañan gravemente el VT.

IMPORTANTE

La massa dei dispositivi collegati alle porte di comunicazione seriali e/o parallele deve essere tassativamente allo stesso potenziale dello 0V di alimentazione del VT. La circolazione di una corrente tra lo 0V di alimentazione e la massa delle porte di comunicazione potrebbe causare il danneggiamento di alcuni componenti del VT o dei dispositivi ad esso collegati.

IMPORTANT

The earth of the devices connected to the serial and/or parallel communication ports MUST have the same potential as the 0V supply of the VT. The circulation of current between the 0V supply and the earth of the communication ports could cause damage to certain components of the VT or of the devices connected to it.

IMPORTANT

La masse des dispositifs connectés aux ports de communication parallèles ou sériels doit formellement être au même potentiel qu'il 0V d'alimentation du VT. La circulation d'un courant entre il 0V d'alimentation et la masse des ports de communication pouvait causer des dommages aux composants du VT ou des dispositifs connectés.

WICHTIG

Die Erde der Parallelen und/oder Seriellen Datenleitung müssen das gleiche Potential haben wie die Erde der Spannungsversorgung vom Bediengerät. Eine nicht korrekte Erdung der Spannungsversorgung und der Datenleitungen können schwere Schäden an den Bediengeräten sowie an den angeschlossene Komponenten hervor rufen.

ATENCIÓN

La masa de los dispositivos conectados en los puertos de comunicación serie y/o paralelo tiene que estar conectada imprescindiblemente al mismo potencial del 0V de alimentación del VT. La circulación de una corriente entre el 0V de alimentación y la masa de los puertos de comunicación podría causar daños a algunos componentes del VT o bien a algunos dispositivos conectados.

Fusibile / Fuse / Fusible / Schmelzsicherung / Fusible

800 mA (5 x 20 mm)

Temperatura di esercizio / Working temperature / Température d'exercice / Betriebstemperatur / Temperatura de servicio

Display / Display / Afficheur / Display / Pantalla: 0 / +50°C

**Porte di comunicazione / Communication ports / Portes de communication /
Schnittstellen-Anschlüsse / Puertos de comunicación**

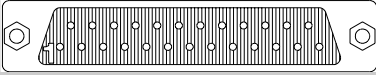
MSP	
	
Db 25 female connector	
Pin	Signal
1	N.C.
2	Tx RS232 OUT
3	Rx RS232 IN
4	RTS RS232 OUT
5	CTS RS232 IN
6	N.C.
7	Signal GND
8	N.C.
9	*Tx C.L. +OUT
10	Tx Rx485 -IN/OUT
11	*Tx C.L. -OUT
12	Tx RS422 -OUT
13	Rx RS422 + IN
14	IKT OUT
15	IKR OUT
16	+ 5 VCC (reserved)
17	N.C.
18	*Rx C.L. +IN
19	N.C.
20	N.C.
21	N.C.
22	Tx Rx485 +IN/OUT
23	Tx RS422 +OUT
24	Rx RS422 -IN
25	*Rx C.L. -IN

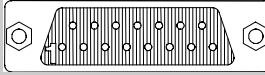
ASP	
	
Db 15 female connector	
Pin	Signal
1	DCD IN
2	RX IN
3	TX OUT
4	DTR OUT
5	Signal GND
6	N.C.
7	Signal GND
8	Tx Rx485 +IN/OUT
9	DSR IN
10	RTS OUT
11	CTS IN
12	RI IN
13	N.C.
14	N.C.
15	Tx Rx485 -IN/OUT

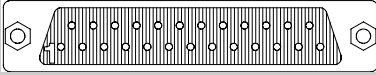
LPT	
	
Db 25 female connector	
Pin	Signal
1	Strobe
2	PRN Data 0
3	PRN Data 1
4	PRN Data 2
5	PRN Data 3
6	PRN Data 4
7	PRN Data 5
8	PRN Data 6
9	PRN Data 7
10	N.C.
11	PRN Busy
12	N.C.
13	N.C.
14	N.C.
15	N.C.
16	N.C.
17	N.C.
18	Signal GND
19	Signal GND
20	Signal GND
21	Signal GND
22	Signal GND
23	Signal GND
24	Signal GND
25	Signal GND

*C.L.: Current Loop (TTY).
N.C. : Not connected.

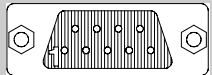
NETWORK1 Profibus-DP	
	
Db 9 female connector	
Pin	Signal
1	Shield
2	N.C.
3	TXRX485+ Data B
4	Repeater-Control-signal RTS
5	Signal GND
6	P5V
7	N.C.
8	TXRX485- Data A
9	N.C.



ESA elettronica S.p.A.
Via Padre Masciadri, 4/A
I - 22066 Mariano Comense (CO)
Tel. ++39-031757400 Fax ++39-031751777
web: <http://www.esahmi.com> e-mail: customer.care@esahmi.com