

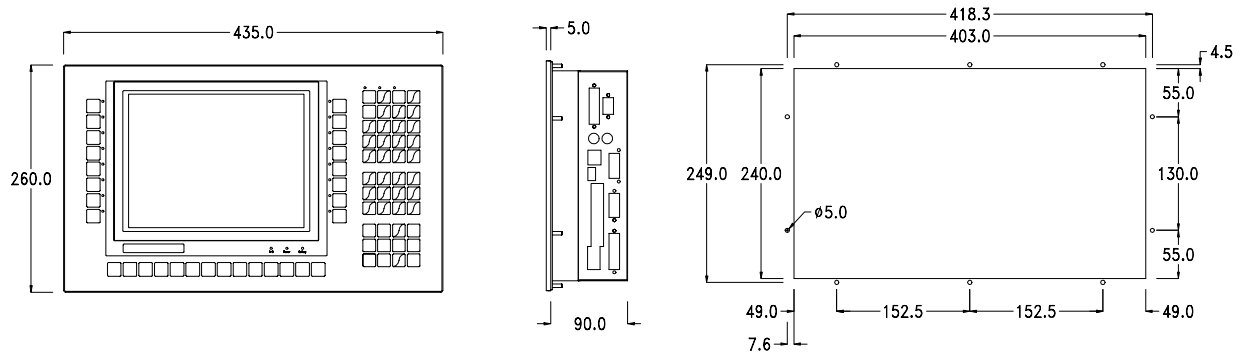

VTCE TERMINALI OPERATORE UNIVERSALI
VTCE UNIVERSAL OPERATOR TERMINALS
VTCE TERMINAUX OPERATEURS UNIVERSELS
VTCE UNIVERSELLE BEDIENTERMINALS
VTCE TERMINALES DE OPERADOR UNIVERSALES

**Dimensioni - Forature / Dimensions - Holes / Dimensions - Trous /
Abmessungen - Bohrungen / Dimensiones y perforaciones**

VT330CE



Posteriore / Rear side / Face arrières / Rückseiten / Posterior

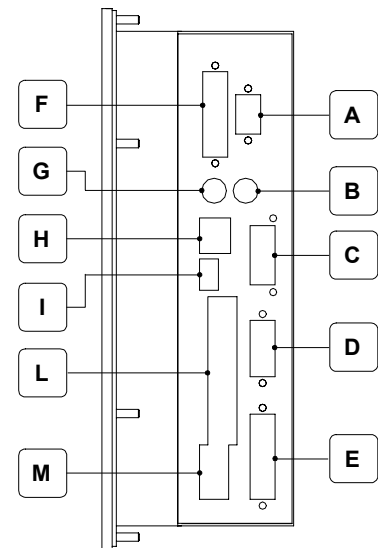
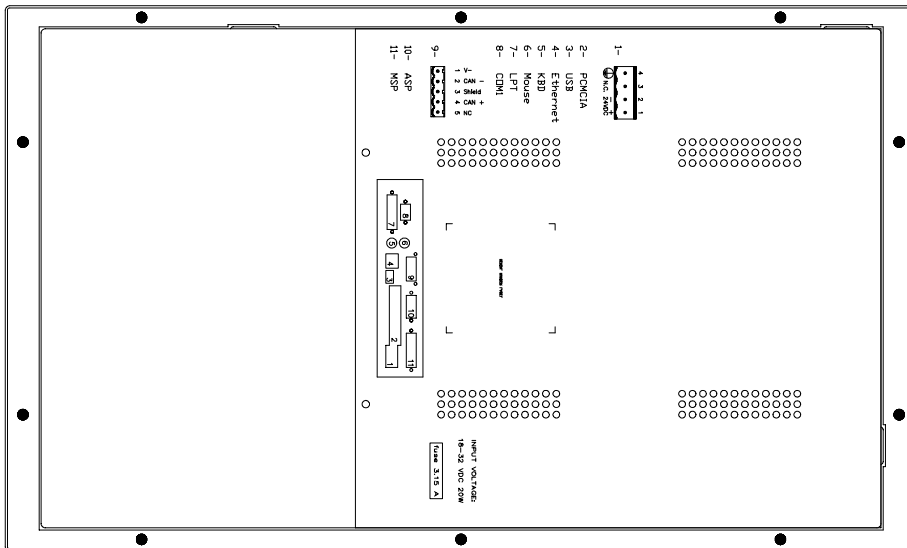

<p>A COM1 Porta seriale standard. Standard serial port. Port sériel standard. Standard Serieller Port. Puerto serie estándar.</p>	<p>G KBD Porta tastiera PS/2. Keyboard PS/2 port. Port clavier PS/2. Externe Tastatur PS/2 Port. Puerto teclado externo PS/2.</p>
<p>B MOUSE Porta mouse PS/2. Mouse PS/2 port. Port souris PS/2. Mouse PS/2 Port. Puerto mouse PS/2.</p>	<p>H Ethernet Ethernet 10/100 Mbit - Rj45. Ethernet 10/100 Mbit - Rj45. Ethernet 10/100 Mbit - Rj45. Ethernet 10/100 Mbit - Rj45. Ethernet 10/100 Mbit - Rj45.</p>
<p>C ASP (Opzione / Option / En option / Optionell / Opción) Porta seriale per la comunicazione con PC o altri dispositivi. Serial port for communicating with PC or other devices. Port sériel pour la communication avec le PC ou autre dispositif. Serielle Schnittstelle für die Kommunikation mit PC oder mit anders Gerät. Puerto serie para la comunicación con PC o otro aparatos</p>	<p>I USB Porta seriale USB. USB port. Port USB. USB Port. Puerto USB.</p>
<p>D CAN (Opzione / Option / En option / Optionell / Opción) Porta seriale CAN. CAN serial port. Port sériel CAN. Serieller Port CAN. Puerto serie CAN.</p>	<p>L PCMCIA Slot PCMCIA Tipo I. PCMCIA Type I slots. Slot PCMCIA Type I. PCMCIA Typ I Steckplätze. Slot PCMCIA Tipo I.</p>
<p>E MSP (Opzione / Option / En option / Optionell / Opción) Porta seriale per la comunicazione con PLC/PC. Serial port for communicating with PLC/PC. Port sériel pour la communication avec le PLC/PC. Serielle Schnittstelle für die Kommunikation mit SPS/PC. Puerto serie para la comunicación con PLC/PC.</p>	<p>M Connettore di alimentazione. Power supply connector. Connecteur d'alimentation. Anschluß für die Spannungsversorgung. Conector de alimentación.</p>
<p>F LPT Porta parallela. Parallel port. Port parallèle. Paralleler Port. Puerto paralelo.</p>	

Terminazione linea CAN / CAN line termination / Extremité de ligne CAN / CAN-Leitungsende / Extremo de línea CAN

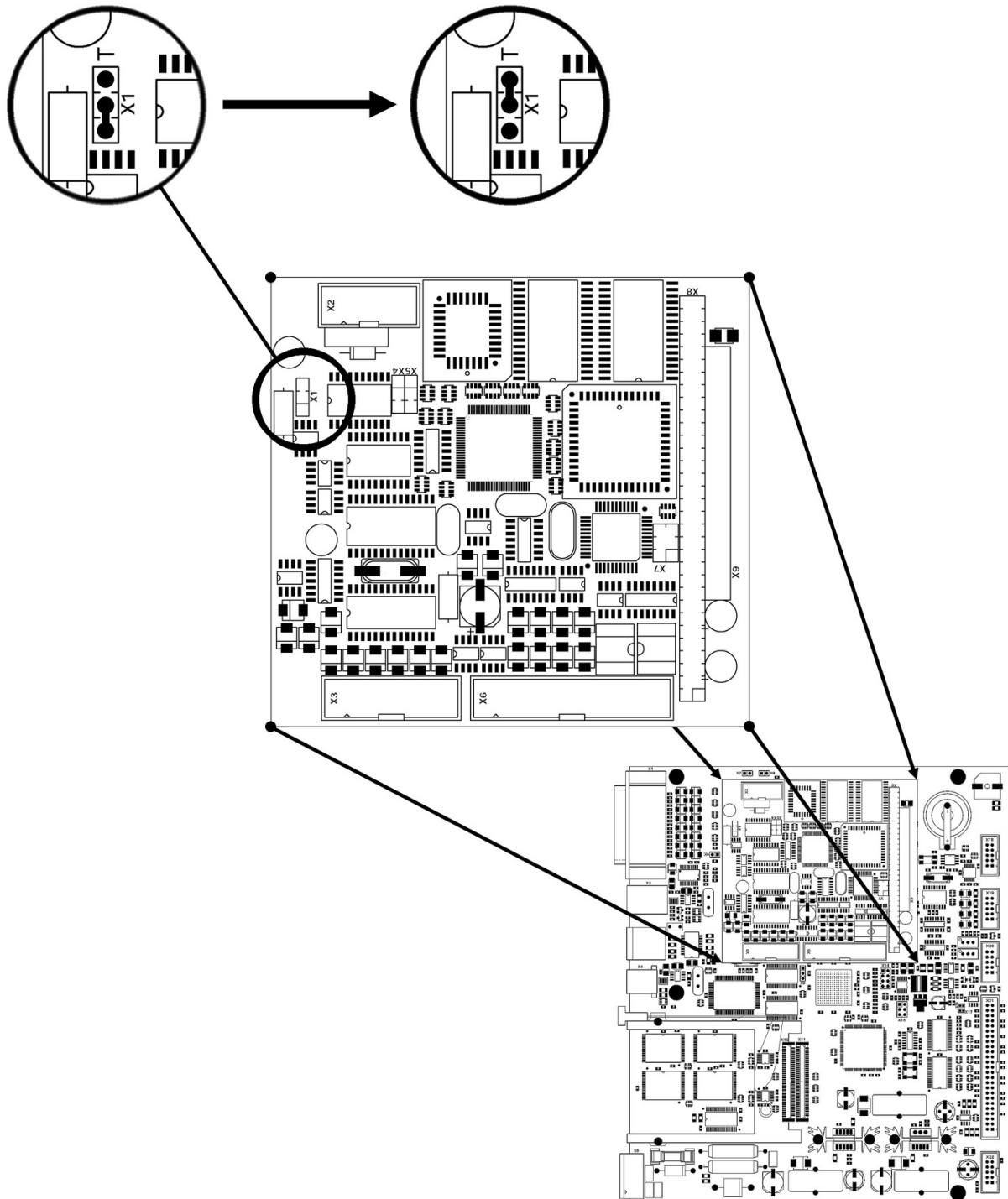

<p>Linea aperta (default) / Open line (default) / Ligne ouverte (défaut) / Offene Leitung (default) / Línea abierta (default)</p>	<p>Linea terminata (120 ohm) / Line termination (120 Ohms) / Extremité de ligne (120 Ohm) / Leitungsende (120 Ohm) / Línea extrema (120 ohm)</p>
<p>X1 pin 1-2</p>	<p>X1 pin 2-3 (T)</p>

Alimentazione / Power supply / Alimentation / Spannungsversorgung / Alimentación

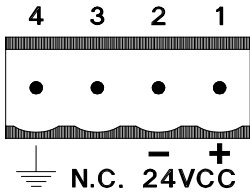

Power supply 4 pins connector	
1	+L 24 VDC
2	M 0 V
3	Not connected
4	PE Protective ground

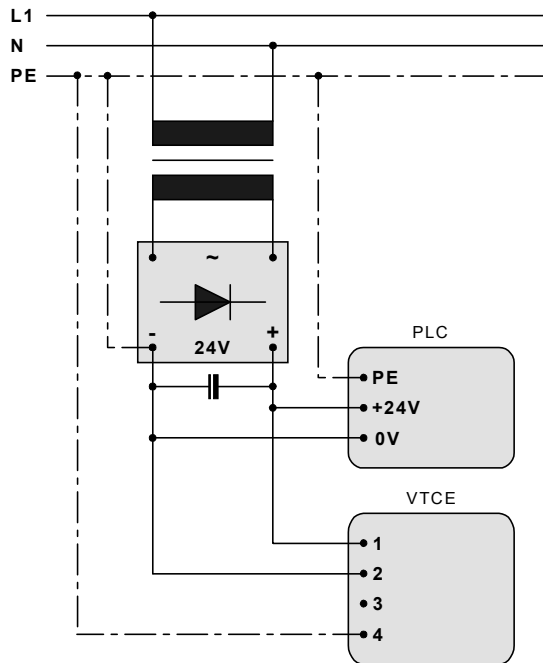

Attenzione: Queste due configurazioni danneggiano gravemente il VTCE.
Warning: These two configuration will seriously damage components.
Attention: Ces deux configurations peuvent endommager certains composants.
Warnung: Diese beiden Anschlussarten führen zu Schäden am VTCE Gerät.
Atencion: Las dos configuraciones de arriba dañan gravemente el VTCE.

IMPORTANTE

La massa dei dispositivi collegati alle porte di comunicazione seriali e/o parallele deve essere tassativamente allo stesso potenziale dello 0V di alimentazione del VTCE. La circolazione di una corrente tra lo 0V di alimentazione e la massa delle porte di comunicazione potrebbe causare il danneggiamento di alcuni componenti del VTCE o dei dispositivi ad esso collegati.

IMPORTANT

The earth of the devices connected to the serial and/or parallel communication ports **MUST** have the same potential as the 0V supply of the VTCE. The circulation of current between the 0V supply and the earth of the communication ports could cause damage to certain components of the VTCE or of the devices connected to it.

IMPORTANT

La masse des dispositifs connectés aux ports de communication parallèles ou sériels doit formellement être au même potentiel qu'il 0V d'alimentation du VTCE. La circulation d'un courant entre le 0V d'alimentation et la masse des ports de communication pourrait causer des dommages aux composants du VTCE ou des dispositifs connectés.

WICHTIG

Die Erde der Parallelen und/oder Seriellen Datenleitung müssen das gleiche Potential haben wie die Erde der Spannungsversorgung vom Bediengerät. Eine nicht korrekte Erdung der Spannungsversorgung und der Datenleitungen können schwere Schäden an den Bediengeräten sowie an den angeschlossene Komponenten hervor rufen.

ATENCIÓN

La masa de los dispositivos conectados en los puertos de comunicación serie y/o paralelo tiene que estar conectada imprescindiblemente al mismo potencial del 0V de alimentación del VTCE. La circulación de una corriente entre el 0V de alimentación y la masa de los puertos de comunicación podría causar daños a algunos componentes del VTCE o bien a algunos dispositivos conectados.

Fusibile / Fuse / Fusible / Schmelzicherung / Fusible

3.15 A (5 x 20 mm)

Temperatura di esercizio / Working temperature / Température d'exercice / Betriebstemperatur / Temperatura de servicio

Display / Display / Afficheur / Display / Pantalla: 0 / +50°C

**Porte di comunicazione / Communication ports / Portes de communication /
Schnittstellen-Anschlüsse / Puertos de comunicación**

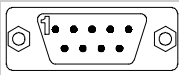
COM1	
	
Db 9 male connector	
1	DCD1 IN
2	RX1 IN
3	TX1 OUT
4	DTR1 OUT
5	Signal GND
6	DSR1 IN
7	RTS1 OUT
8	CTS1 IN
9	RI1 IN

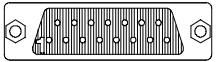
ASP	
	
Db 15 female connector	
1	DCD IN
2	RX IN
3	TX OUT
4	DTR OUT
5	Signal GND
6	N.C.
7	Signal GND
8	Tx/Rx +IN/OUT
9	DSR IN
10	RTS OUT
11	CTS IN
12	RI IN
13	+5Vcc (150mA Max.)
14	N.C.
15	Tx/Rx -IN/OUT

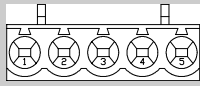
CAN	
	
5 pin female connector	
1	V-
2	CAN -
3	Shield
4	CAN +
5	N.C.

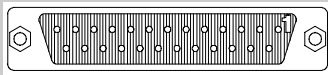
MSP	
	
Db 25 female connector	
1	N.C.
2	Tx RS232 OUT
3	Rx RS232 IN
4	RTS RS232 OUT
5	CTS RS232 IN
6	N.C.
7	Signal GND
8	N.C.
9	*Tx C.L. +OUT
10	Tx Rx485 -IN/OUT
11	*Tx C.L. -OUT
12	Tx RS422 -OUT
13	Rx RS422 + IN
14	IKT OUT
15	IKR OUT
16	+ 5 VCC (reserved)
17	N.C.
18	*Rx C.L. +IN
19	N.C.
20	N.C.
21	N.C.
22	Tx Rx485 +IN/OUT
23	Tx RS422 +OUT
24	Rx RS422 -IN
25	N.C.

MOUSE	
	
Minidin 6 female connector	
1	MSDATA
2	N.C.
3	Signal GND
4	PS2VCC
5	MSCLK
6	N.C.

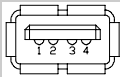
USB	
	
4 pin male connector	
1	USBVCC
2	USBD-
3	USBD+
4	Signal GND

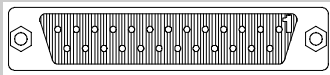
LPT	
	
Db 25 female connector	
1	BSTRB
2	BPD0
3	BPD1
4	BPD2
5	BPD3
6	BPD4
7	BPD5
8	BPD6
9	BPD7
10	BACK
11	BBUSY
12	BPE
13	BSLCT
14	BAFDT
15	BERROR
16	BINIT
17	BSLCTIN
18	GND
19	GND
20	GND
21	GND
22	GND
23	GND
24	GND
25	GND

KBD	
	
Minidin 6 female connector	
1	TPDATA
2	N.C.
3	Signal GND
4	PS2VCC
5	TPCLK
6	N.C.

Ethernet	
	
RJ45 8 pin female connector	
1	TX+
2	TX-
3	RX+
4	--
5	--
6	RX-
7	--
8	--

*C.L.: Current Loop (TTY).
N.C. : Not connected.



ESA elettronica S.p.A.
Via Padre Masciadri, 4/A
I - 22066 Mariano Comense (CO)
Tel. ++39-031757400 Fax ++39-031751777
web: <http://www.esahmi.it> e-mail: esahotln@esahmi.it

Mind over matter