



YASKAWA

YASKAWA AC Drive-Option Card

DeviceNet

Installation Manual

Type SI-N3

To properly use the product, read this manual thoroughly and retain for easy reference, inspection, and maintenance. Ensure the end user receives this manual.

安川インバータ オプションカード

DeviceNet 通信

取扱説明書

形式 SI-N3

製品を安全にお使い頂くために、この取扱説明書を必ずお読みください。
また、本書をお手元に保管していただくとともに、最終的に本製品をご使用になるユーザー様のお手元に確実に届けられるよう、お取り計らい願います。

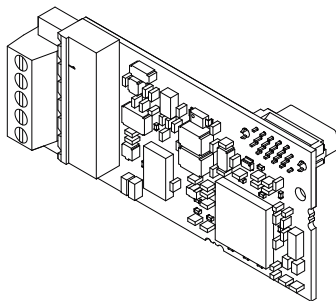

This Page Intentionally Blank



Table of Contents

1 PREFACE AND SAFETY	4
2 PRODUCT OVERVIEW	8
3 RECEIVING	9
4 DEVICENET OPTION COMPONENTS	10
5 INSTALLATION PROCEDURE	14
6 DEVICENET OPTION DRIVE PARAMETERS	22
7 TROUBLESHOOTING	25
8 CONFIGURING DEVICENET MESSAGING	28
9 SPECIFICATIONS	31

Copyright © 2008 YASKAWA ELECTRIC CORPORATION

All rights reserved. No part of this publication may be reproduced, stored in a retrieval system, or transmitted, in any form or by any means, mechanical, electronic, photocopying, recording, or otherwise, without the prior written permission of Yaskawa. No patent liability is assumed with respect to the use of the information contained herein. Moreover, because Yaskawa is constantly striving to improve its high-quality products, the information contained in this manual is subject to change without notice. Every precaution has been taken in the preparation of this manual. Yaskawa assumes no responsibility for errors or omissions. Neither is any liability assumed for damages resulting from the use of the information contained in this publication.

1 Preface and Safety

Yaskawa manufactures products used as components in a wide variety of industrial systems and equipment. The selection and application of Yaskawa products remain the responsibility of the equipment manufacturer or end user. Yaskawa accepts no responsibility for the way its products are incorporated into the final system design. Under no circumstances should any Yaskawa product be incorporated into any product or design as the exclusive or sole safety control. Without exception, all controls should be designed to detect faults dynamically and fail safely under all circumstances. All systems or equipment designed to incorporate a product manufactured by Yaskawa must be supplied to the end user with appropriate warnings and instructions as to the safe use and operation of that part. Any warnings provided by Yaskawa must be promptly provided to the end user. Yaskawa offers an express warranty only as to the quality of its products in conforming to standards and specifications published in the Yaskawa manual. **NO OTHER WARRANTY, EXPRESSED OR IMPLIED, IS OFFERED.** Yaskawa assumes no liability for any personal injury, property damage, losses, or claims arising from misapplication of its products.

◆ Applicable Documentation

The following manuals are available for the DeviceNet Option:

Option Card

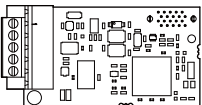
	YASKAWA AC Drive-Option Card DeviceNet Installation Manual Manual No. : TOBPC73060043
	Read this manual first. The installation manual is packaged with the DeviceNet Option and contains a basic overview of wiring, settings, functions, and fault diagnoses.
	YASKAWA AC Drive-Option Card DeviceNet Technical Manual (This book) Manual No. : SIEPC73060043
	The technical manual contains detailed information. To obtain the technical manual access these sites: Europe: http://www.yaskawa.eu.com Japan: http://www.e-mechatronics.com Other areas: contact a Yaskawa representative.

Yaskawa Drive

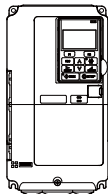
	Refer to the manual of the drive this option card is being used with. The instruction manual for the drive covers basic installation, wiring, operation procedures, functions, troubleshooting, and maintenance information. It also includes important information on parameter settings and how to tune the drive. A Quick Start Guide is included with the drive. For the more detailed Technical Manual, visit Yaskawa's homepage. Europe: http://www.yaskawa.eu.com Japan: http://www.e-mechatronics.com Other areas: contact a Yaskawa representative
-------------------------------------------------------------------------------------	-------------------------------------------------------------------------------------------------------------------------------------------------------------------------------------------------------------------------------------------------------------------------------------------------------------------------------------------------------------------------------------------------------------------------------------------------------------------------------------------------------------------------------------------------------------------------------------------------------------------------------------------------------------------

◆ Terms

Note: Indicates a supplement or precaution that does not cause drive damage.

DeviceNet Option: YASKAWA AC Drive -SI-N3 DeviceNet option card

◆ Registered Trademarks

- DeviceNet is a trademark of the ODVA.
- All trademarks are the property of their respective owners.

1 Preface and Safety

◆ Supplemental Safety Information

Read and understand this manual before installing, operating, or servicing this option card. The option card must be installed according to this manual and local codes.

The following conventions are used to indicate safety messages in this manual. Failure to heed these messages could result in serious or possibly even fatal injury or damage to the products or to related equipment and systems.

DANGER

Indicates a hazardous situation, which, if not avoided, will result in death or serious injury.

WARNING

Indicates a hazardous situation, which, if not avoided, could result in death or serious injury.

CAUTION

Indicates a hazardous situation, which, if not avoided, could result in minor or moderate injury.

NOTICE

Indicates an equipment damage message.

■ General Safety

General Precautions

- The diagrams in this section may include option cards and drives without covers or safety shields to illustrate details. Be sure to reinstall covers or shields before operating any devices. The option should be used according to the instructions described in this manual.
- Any illustrations, photographs, or examples used in this manual are provided as examples only and may not apply to all products to which this manual is applicable.
- The products and specifications described in this manual or the content and presentation of the manual may be changed without notice to improve the product and/or the manual.
- When ordering a new copy of the manual due to damage or loss, contact your Yaskawa representative or the nearest Yaskawa sales office and provide the manual number shown on the front cover.

DANGER

Heed the safety messages in this manual.

Failure to comply will result in death or serious injury.

The operating company is responsible for any injuries or equipment damage resulting from failure to heed the warnings in this manual.

NOTICE

Do not expose the drive to halogen group disinfectants.

Failure to comply may cause damage to the electrical components in the option card.

Do not pack the drive in wooden materials that have been fumigated or sterilized.

Do not sterilize the entire package after the product is packed.

Do not modify the drive circuitry.

Failure to comply could result in damage to the drive and will void warranty.

YASKAWA is not responsible for any modification of the product made by the user. This product must not be modified.

2 Product Overview

◆ About This Product

The DeviceNet option provides a communications connection between the drive and an ODVA DeviceNet network. The SI-N3 DeviceNet Option connects the drive to a DeviceNet network and facilitates the exchange of data.

This manual explains the handling, installation and specifications of this product.

DeviceNet is a communications link to connect industrial devices (such as limit switches, photoelectric switches, valve manifolds, motor starters, smart motor controllers, operator interfaces, and variable frequency drives) as well as control devices (such as programmable controllers and computers) to a network. DeviceNet is a simple, networking solution that reduces the cost and time to wire and install factory automation devices, while providing interchangeability of "like" components from multiple vendors.

By installing the DeviceNet Option to a drive, it is possible to do the following from a DeviceNet master device:

- Operate the drive
- Monitor the operation status of the drive
- Change parameter settings.



Figure 1 DeviceNet Approved





3 Receiving

Please perform the following tasks after receiving the DeviceNet Option:

- Inspect the DeviceNet Option for damage.
If the DeviceNet Option appears damaged upon receipt, contact the shipper immediately.
- Verify receipt of the correct model by checking the information on the PCB (see [Figure 2](#)).
- If you have received the wrong model or the DeviceNet Option does not function properly, contact your supplier.

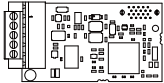
◆ Contents and Packaging

Table 1 Contents of Package

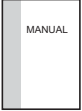
Description:	Option Card	Ground Cable	Screws	LED Label	Installation Manual
					
Quantity:	1	1	3	1	1

◆ Tool Requirements

A Phillips screwdriver (M3) metric or (#1, #2) U.S. standard size is required to install the DeviceNet Option.

A straight-edge screwdriver (M2) is required to wire the terminal block.

4 DeviceNet Option Components

◆ DeviceNet Option

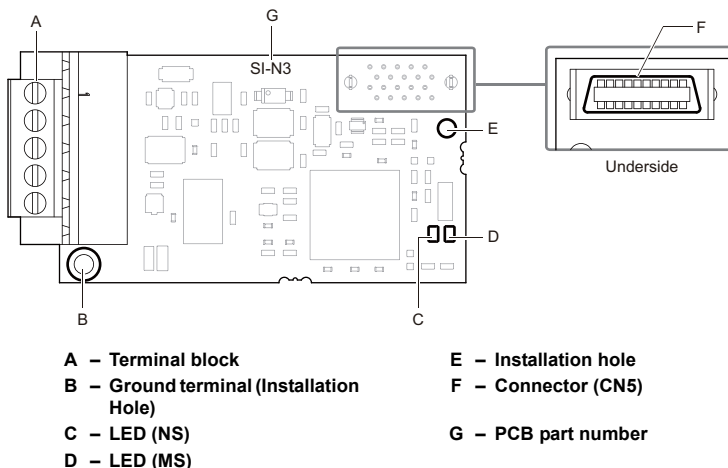

Figure 2 Option Card

Note: For details on the LEDs, [Refer to DeviceNet Option LED Display on page 11.](#)

◆ Terminal Block

The communication connector is a pluggable terminal block. This pluggable terminal block is the connection point of the DeviceNet network communication cable to the Option.

Table 2 Terminal Descriptions

Terminal	Pin	Color	Signal	Description
	1	Black	V-	Network common
	2	Blue	CAN_L	CAN data Low
	3	–	Shield	Cable shield
	4	White	CAN_H	CAN data High
	5	Red	V+	Communications DC+24V

◆ DeviceNet Option LED Display

The DeviceNet Option has two bicolor , red/green LEDs, one for Module Status (MS) and one for Network Status (NS).

The operational states of the DeviceNet Option LEDs after the DeviceNet power-up diagnostic LED sequence is completed are described in [Table 4](#). Wait at least 2 seconds for the power-up diagnostic process to complete before verifying the states of the LEDs.

Table 3 DeviceNet Operation LED States

Name	Indication		Operating Status	Remarks
	Color	Status		
MS	–	OFF	Power supply OFF	Power is not being supplied to the drive.
	Green	ON	SI-N3 Option operating	The SI-N3 Option card is operating normally.
	Green	Flashing	SI-N3 Option initializing	There is an incorrect baud rate setting or there is a MAC ID.
	Red	ON	Fatal error occurred	A fatal (irrecoverable) error occurred in the SI-N3 Option.
	Red	Flashing	Non-fatal error occurred	A non-fatal (recoverable) error occurred.
	Green/Red	Flashing	Device self-test	Device in self-test mode.
NS	–	OFF	Offline or Power supply OFF	–
	Green	ON	Online communications established	Device is on-line and has connections in the established state.
	Green	Flashing	Online communications not established	Device is on-line but has no connections in the established state. Dup Mac-ID test has been passed, is on-line but has no open connections to other nodes.
	Red	ON	Communications error	An error occurred that disables DeviceNet communications. MAC ID duplication Bus Off detected
	Red	Flashing	Communications time-out	A communications time-out occurred with the master.
	Green/Red	Flashing	Communication faulted	Specific communication faulted device. The device has detected a network access error and is in the communications faulted state. The device has then received and accepted an Identify communication fault request-long protocol message.

4 DeviceNet Option Components

■ Power-Up Diagnostics

An LED test is performed each time the drive is powered up. The initial boot sequence may take several seconds. After the LEDs have completed the DeviceNet diagnostic LED sequence, the DeviceNet Option is successfully initialized. The LEDs then assume operational conditions as shown in [Table 3](#).

Table 4 Power-Up Diagnostic LED Sequence

Sequence	Module Status (MS)	Network Status (NS)	Time (ms)
1	GREEN	OFF	250
2	RED	OFF	250
3	GREEN	GREEN	250
4	GREEN	RED	250
5	GREEN	OFF	-

◆ Set the DeviceNet Option MAC ID

■ Parameter F6-50, MAC ID Setting

Range: 0~64

The MAC ID is set by drive parameter F6-50. A MAC ID setting in the range of 0~63 is considered a valid MAC ID. A value other than 0~63 indicates the MAC ID is settable over the network.

The DeviceNet Option SI-N3 reads the MAC ID value from parameter F6-50 upon power-up and upon a network reset.

◆ Set the DeviceNet Option Baud Rate

The DeviceNet Option will support standard baud rates of 125 k bit/s, 250 k bit/s, and 500 k bit/s.

Table 5 Parameter F6-51 Baud Rate Setting

Description	Value
125 k bit/s	0
250 k bit/s	1
500 k bit/s	2
Programmable From Network	3
Auto Detect	4

■ Auto Baud Rate Sensing (F6-51 = 4)

Setting parameter F6-51 = 4, "Auto Detect" causes the DeviceNet Option to determine the data rate of the DeviceNet Network and configure itself appropriately.

Note: The auto baud capability will only be valid when there is more than one node physically on the DeviceNet network segment. The drive digital operator will display "bUS" and the DeviceNet option LEDs will be (NS-OFF and MS=Solid Green) as long as auto baud rate sensing fails to detect the baud rate.

5 Installation Procedure

◆ Section Safety

DANGER

Electrical Shock Hazard

Power to the drive must be shut off when installing the DeviceNet Option.

Even though the power has been shut off, voltage still remains in the drive's DC bus. Wait before removing the front cover once the drive has been turned off.

The CHARGE light on the drive will go out after voltage in the DC bus drops below 50 V, at which point it is safe to remove the front cover.

Due to the risk of electric shock, be sure that all LEDs have gone out and that the DC bus voltage has reached a safe level prior to performing any work on the drive.

WARNING

Electrical Shock Hazard

Do not remove the front cover of the drive while the power is on.

Failure to comply could result in death or serious injury.

The diagrams in this section may include option cards and drives without covers or safety shields to show details. Be sure to reinstall covers or shields before operating any devices.

The option should be used according to the instructions described in this manual.

Do not allow unqualified personnel to use equipment.

Failure to comply could result in death or serious injury.

Maintenance, inspection, and replacement of parts must be performed only by authorized personnel familiar with installation, adjustment, and maintenance of this product.



WARNING

Do not touch circuit boards while the power to the drive is on.

Failure to comply could result in death or serious injury.

Do not use damaged wires, place excessive stress on wiring, or damage the wire insulation.

Failure to comply could result in death or serious injury.

NOTICE

Damage to Equipment

Observe proper electrostatic discharge (ESD) procedures when handling the option card, drive, and circuit boards.

Failure to comply may result in ESD damage to circuitry.

Never shut the power off while the drive is outputting voltage.

Failure to comply may cause the application to operate incorrectly or damage the drive.

Do not operate damaged equipment.

Failure to comply may cause further damage to the equipment.

Do not connect or operate any equipment with visible damage or missing parts.

Tighten all terminal screws to the specified tightening torque.

Loose electrical connections could result in death or serious injury by fire due to overheating of electrical connections.

Do not use unshielded cable for control wiring.

Failure to comply may cause electrical interference resulting in poor system performance.

Use shielded twisted-pair wires and ground the shield to the ground terminal of the drive.

5 Installation Procedure

NOTICE

Properly connect all pins and connectors.

Failure to comply may prevent proper operation and possibly damage equipment.

Check wiring to ensure that all connections are correct after installing the option card and connecting any other devices.

Failure to comply may result in damage to the option card.

◆ Wiring Diagram

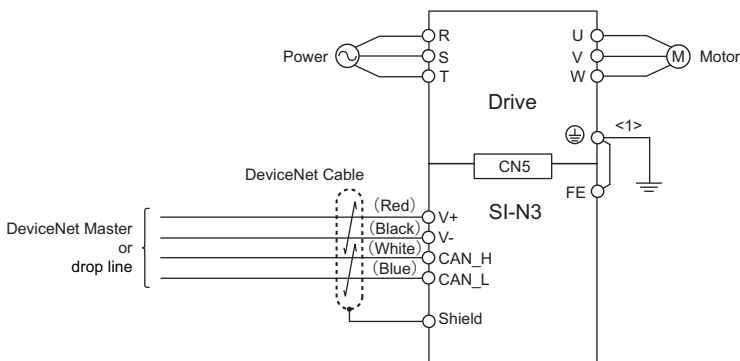

Figure 3 Wiring Diagram

<1> The FE terminal on the DeviceNet Option is supplied with a ground cable that should be connected to the ground terminal on the drive.

◆ Prior to Installing the Option Card

Prior to installing the DeviceNet Option, wire the drive and make necessary connections to the drive terminals. Refer to the Quick Start Guide for information on wiring and connecting the drive. Verify that the drive functions normally prior to installing the Option.

◆ Installing the Card Option

This DeviceNet Option can be inserted into the either only CN5-A connectors located on the drive's control board.

See the drive manual for directions on removing the front cover.

1. Shut off power to the drive, wait the appropriate amount of time for voltage to dissipate, then remove the operator and front cover.
2. Insert the CN5 connector on the DeviceNet Option into the matching CN5 connector on the drive, then fasten it into place using one of the screws included with the DeviceNet Option.
Connect one of the lead lines using one of the screws to the ground terminal. Three separate lead lines have been included with the DeviceNet Option to connect to three separate ports. Use the lead line with the length appropriate for the distance of the port.

Note: There are only two screw holes on the drive for ground terminals. If three option cards are connected, two of the lead lines will need to share the same ground terminal.

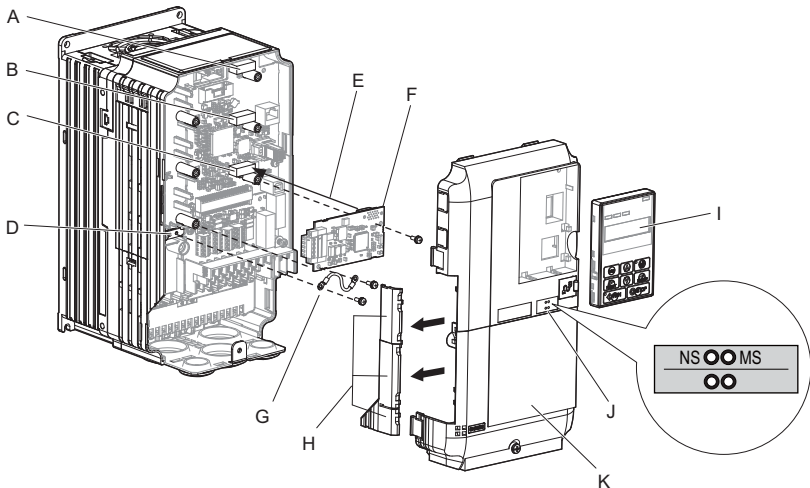

A – Connector CN5-C

B – Connector CN5-B

C – Connector CN5-A

D – Drive grounding terminal (FE)

E – Insert connector CN5 here

F – DeviceNet Option

G – Lead line

H – Use wire cutters to create an opening for cable lines

I – Operator

J – LED label

K – Front cover

Figure 4 Installing the Option

5 Installation Procedure

- 3.** Wire the DeviceNet Option to the terminal block on the DeviceNet Option.
For exposed cables in drives 2A004 to 0069, 4A0002 to 0044, use a pair of wire cutters to create an opening on the left side of the front cover that allows wiring to pass through. Sharp edges along the opening that was created should be smoothed down with a file or sand paper so prevent any damage to the wires.
Drives 2A0081 to 0021, 4A0058 to 0165 have enough space to keep all wiring inside the unit.

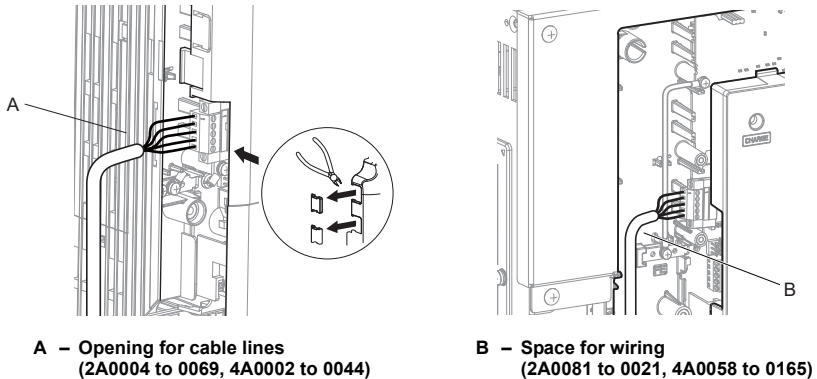

Figure 5 Wiring space

- 4.** Place the front cover back onto the drive as it was before.

Note:

1. Take care when wiring the DeviceNet Option so that the front cover easily fits back onto the drive.
2. Install Cable Cover option to maintain the drive Enclosure Type.

◆ Communication Cable Wiring

■ Procedure

Follow the instructions below to connect the communications cable to the terminal block.

WARNING! Tighten all terminal screws according to the specified tightening torque. Tightening screws too tight could damage the terminal block, and leaving screws too loose can cause a short-circuit or drive malfunction.

1. Connect the communications cable to the terminal block as shown in the diagram below.

Note: Communication lines should be separated from main circuit wiring and other electrical lines. (Tightening torque: 0.5 to 0.6 (N·m) or 4.4 to 5.3 (inch-lbs)) for Network Cable Wiring.

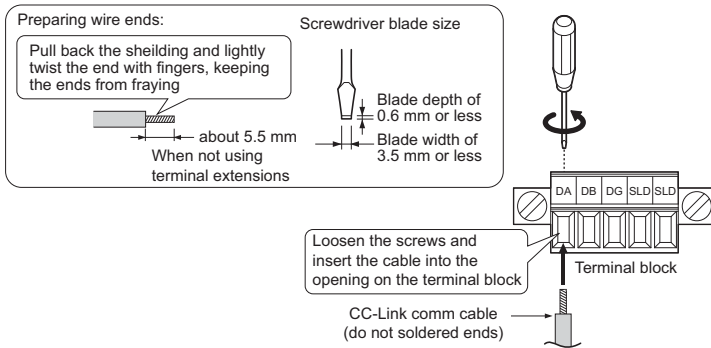

Figure 6 Communication Cable Wiring

2. Ensure all wiring connections are tightened and wire insulation is not pinched in the terminal block. Remove any stray wire strands that touch other terminals.
3. After the terminal block is fully attached to the option card, tighten the screws on the left and right sides of the terminal block. (Tightening torque: 0.5 to 0.6 (N·m) or 4.4 to 5.3 (inch-lbs)).

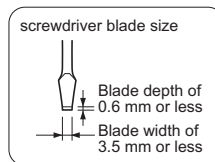

Figure 7 Terminal Block Installation

5 Installation Procedure

◆ Termination Resistor Connection

A network termination resistor (121 Ω \pm 1%, 1/4 W) must be connected only to nodes of the two ends of trunkline. Refer to ODVA specification for more details on DeviceNet termination.

◆ Communication Cable Specifications

Refer to the ODVA website for more information on network cabling (<http://www.odva.org/>).

◆ Cable Length

■ Trunk Line

The maximum allowed trunk line length depends on the type of cable used and the network baud rate. The total cable length includes the length of the trunk and the sum of all the drop lines.

Table 6 Trunk Line Cable Length

Baud Rate (k bit/s)	Thick Cable (m)	Thin Cable (m)
125	500	100
250	250	100
500	100	100

To calculate the maximum total length for trunk lines of mixed thick and thin cables, use the following formulas:

- 125 k bit/s: $L_{\text{thick}} + (5 \times L_{\text{thin}}) \leq 500$ m
- 250 k bit/s: $L_{\text{thick}} + (2.5 \times L_{\text{thin}}) \leq 250$ m
- 500 k bit/s: $L_{\text{thick}} + L_{\text{thin}} \leq 100$ m

■ Drop Line

The drop line is measured from the tap on the trunk line to the transceiver of the DeviceNet node. Note that the total cable length includes the length of the trunk and the sum of all the drop lines.

Table 7 Drop Line Cable Length

Baud Rate (k bit/s)	Maximum at Each Drop (m)	Maximum Total (m)
125	6	156
250		78
500		39

◆ EDS Files

For easy network implementation of drives equipped with a SI-N3, an EDS file can be obtained from:

Europe: <http://www.yaskawa.eu.com>

Japan: <http://www.e-mechatronics.com>

Other areas: contact a Yaskawa representative.

6 DeviceNet Option Drive Parameters

Confirm proper setting of the all parameters in *Table 8* before starting network communications.

Table 8 Parameter Settings

No. (Addr. Hex)	Name	Description	Values
b1-01 (180) <D>	Frequency Reference Selection	Selects the frequency reference input source 0: Digital Operator - Digital preset speed d1-01 to d1-17 1: Terminals - Analog input terminal A1 or A2 2: MEMOBUS/Modbus communications 3: Option PCB 4: Pulse Input (Terminal RP)	Default: 1 Range: 0~4 (Set to 3 for DeviceNet only)
b1-02 (181) <D>	Run Command Selection	Selects the run command input source 0: Digital Operator - RUN and STOP keys 1: Digital input terminals S□ 2: MEMOBUS/Modbus communications 3: Option PCB	Default: 1 Range: 0~3 (Set to 3 for DeviceNet only)
F6-01 (3A2)	Operation Selection after Communications Error	Determines drive response when a bUS error is detected during communications with the DeviceNet Option 0: Ramp to Stop 1: Coast to Stop 2: Fast-Stop 3: Alarm Only <D>	Default: 1 Range: 0~3
F6-02 (3A3)	External Fault Detection Conditions (EF0)	Sets the condition for external fault detection (EF0) 0: Always detected 1: Detected only during operation	Default: 0 Range: 0~1
F6-03 (3A4)	Stopping Method for External Fault from Communication Option	Determines drive response for external fault input (EF0) detection during DeviceNet communication 0: Ramp to Stop 1: Coast to Stop 2: Fast-Stop 3: Alarm Only <D>	Default: 1 Range: 0~3
F6-06 <D>	Torque Reference/ Torque Limit Selection from Communications Option	0: Torque reference / torque limit via network communications are disabled. 1: Torque reference / torque limit via network communications are enabled. <D>	0
F6-07 (3A8)	NetRef/ComRef Selection Function	0: Multi-step speed reference disabled (F7 mode) 1: Multi-step speed reference allowed (V7 mode)	Default: 0

6 DeviceNet Option Drive Parameters

No. (Addr. Hex)	Name	Description	Values
F6-08 (36A)	Reset Communication Related Parameters	Determines which F6-□□ and F7-□□ parameters are reset to default values when the drive is initialized using A1-03. 0: Do not reset parameters 1: Reset parameters	Default: 0
F6-50 (3C1) <-> <->	MAC ID	Selects the drive MAC address Note: Used in the DeviceNet Object	Default: 0 Range: 0~64
F6-51 (3C2) <->	Baud Rate	DeviceNet communication speed 0: 125 k bit/s 1: 250 k bit/s 2: 500 k bit/s 3: Programmable from Network 4: Detect automatically Note: Used in the DeviceNet Object	Default: 0 Range: 0~4
F6-52 (3C3) <->	PCA setting	I/O Polled Consuming Assembly data instance Note: Used in the Connection Object	Default: 21 Range: 0~255
F6-53 (3C4) <->	PPA setting	I/O Polled Producing Assembly data instance Note: Used in the Connection Object	Default: 71 Range: 0~255
F6-54 (3C5) <->	Idle Mode Fault Detection Selection	When detection is enabled and idle messages are detected, the option will set Run and Frequency to 0. 0: Detection enabled 1: No detection	Default: 0 Range: 0~1
F6-55 (3C6)	Baud rate from Network	(Read only) DeviceNet actual communication speed 0: 125 k bit/s 1: 250 k bit/s 2: 500 k bit/s Note: Used in the DeviceNet Object	Range: 0~2
F6-56 (3D7)	Speed Scaling	Sets the scaling factor for the Speed Monitor in the DeviceNet Object Class 2A hex Note: Used in the AC/DC Drive Object	Default: 0 Range: -15~15
F6-57 (3D8)	Current Scaling	Sets the scaling factor for the Output Current Monitor in the DeviceNet Object Class 2A hex Note: Used in the AC/DC Drive Object	Default: 0 Range: -15~15
F6-58 (3D9)	Torque Scaling	Sets the scaling factor for the Torque Monitor in the DeviceNet Object Class 2A hex Note: Used in the AC/DC Drive Object	Default: 0 Range: -15~15
F6-59 (3DA)	Power Scaling	Sets the scaling factor for the Power Monitor in the DeviceNet Object Class 2A hex Note: Used in the AC/DC Drive Object	Default: 0 Range: -15~15

6 DeviceNet Option Drive Parameters

No. (Addr. Hex)	Name	Description	Values
F6-60 (3DB)	Voltage Scaling	Sets the scaling factor for the Voltage Monitor in the DeviceNet Object Class 2A Note: Used in the AC/DC Drive Object	Default: 0 Range: -15~15
F6-61 (3DC)	Time Scaling	Sets the scaling factor for the Time Monitor in the DeviceNet Object Class 2A hex Note: Used in the AC/DC Drive Object	Default: 0 Range: -15~15
F6-62 (3DD)	Heart Beat	Sets the heartbeat interval Note: Used in the Identity Object	Default: 0 Range: 0~10
F6-63 (3DE)	MAC ID from Network	(Read only) Actual MAC address Note: Used in the DeviceNet Object	Range: 0~63
U6-98 (7F8)	Previous Option Fault	Displays previous faulted status. 0: No fault 1: Option failure 2: PLC in idle state 3: Forcefault 1000: Network power loss 1001: Connection timeout 1002: Duplicate MAC ID 1003: Bus-Off Note: Used in DeviceNet Option Faults	Range: 0~3; 1000~1003
U6-99 (7F9)	Current Option Fault	Displays the most recent fault status. 0:No fault 1: Option failure 2: PLC in idle state 3: Force fault 1000: Network power loss 1001: Connection timeout 1002: Duplicate MAC ID 1003: Bus-Off Note: Used in DeviceNet Option Faults	Range: 0~3; 1000~1003

- <1> To start and stop the drive with the DeviceNet master device using serial communications, set b1-02 to “3” or set the “Net Control” bit in the assemblies or Control Supervisor Object. To control the frequency reference of the drive via the master device, set b1-01 to “3” or set the “Net Reference” bit in the assemblies or AC/DC object.
- <2> If F6-01 or F6-03 is set to 3, then the drive will continue to operate when a fault is detected. Take proper safety measures, such as installing an emergency stop switch.
- <3> Enabled in CLV, PM OLV 2, and PM CLV control modes (A1-02 = 3, 6, or 7). When enabled, d5-01 determines whether the value is read as the torque limit value (d5-01 = 0) or read as the torque reference value (d5-01 = 1). In Closed Loop Vector for PM motors, this value is read as the torque limit.
- <4> Default setting specifies that the torque reference or torque limit is to be provided via network communications (F6-06 = 1). The motor may not rotate if no torque reference or torque limit is supplied from the PLC.
- <5> All MAC addresses must be unique.
- <6> PCA and PPA will be initialized if unavailable values are set.
- <7> Power must be cycled in order for any setting changes to take affect.

7 Troubleshooting

◆ Drive-Side Error Codes

Drive-side error codes appear on the drive digital operator. Causes of the errors and corrective actions are listed in [Table 9](#).

For additional error codes that may appear on the digital operator screen, refer to the technical manual for the drive.

■ Faults

Both bUS (DeviceNet Option Communication Error) and EF0 (External Fault Input from the DeviceNet Option) can appear as an alarm or as a fault. When a fault occurs, the digital operator ALM LED remains. When an alarm occurs, the digital operator ALM LED flashes.

If communication stops while the drive is running, answer the following questions to help remedy the fault:

- Is the DeviceNet Option properly installed?
- Is the communication line properly connected to the DeviceNet Option? Is it loose?
- Is the controller program working? Has the controller CPU stopped?
- Did a momentary power loss interrupt communications?

Table 9 Fault Display and Possible Solutions

Digital Operator Display		Fault Name
bUS	bUS	DeviceNet Option Communication Error
		After establishing initial communication, the connection was lost. Only detected when the run command frequency reference is assigned to the option (bl-01 = 3 or bl-02 = 3).
Cause		Possible Solution
Master controller (PLC) has stopped communicating.		Check for faulty wiring. Correct any wiring problems.
Communication cable is not connected properly.		
A data error occurred due to noise.		Check the various options available to minimize the effects of noise. Take steps to counteract noise in the control circuit wiring, main circuit lines, and ground wiring. If a magnetic contactor is identified as a source of noise, install a surge absorber to the contactor coil. Make sure the cable used fulfills the DeviceNet requirements. Ground the shield on the controller side and on the DeviceNet Option side.
DeviceNet Option is damaged.		If there are no problems with the wiring and the error continues to occur, replace the DeviceNet Option.
Network power loss		The power on the DeviceNet network cable is 0. Verify power is available between option terminals V+ (red) and V- (black).

7 Troubleshooting

Connection timeout	The DeviceNet option Expected Packet Rate (EPR) timer timed out. Make sure that EPR time is set properly.	
Duplicate MAC ID	The DeviceNet option MAC ID and at least one other mode have the same MAC ID. Verify F6-50 is set properly.	
Digital Operator Display		Fault Name
\square EF0	EF0	External Fault Input from DeviceNet Option
		The alarm function for an external device has been triggered.
Cause		Possible Solution
An external fault is being sent from the upper controller (PLC).		Remove the cause of the external fault. Reset the external fault input from the PLC device.
Problem with the PLC program.		Check the program used by the PLC and make the appropriate corrections.
Digital Operator Display		Fault Name
\square FA00	oFA00	DeviceNet Option Fault (CN5-A)
		DeviceNet Option is not properly connected.
Cause		Possible Solution
Non-compatible option connected to the drive.		Connect an option that is compatible with the drive.
Digital Operator Display		Fault Name
\square FA01	oFA01	DeviceNet Option Fault (CN5-A)
		DeviceNet Option is not properly connected.
Cause		Possible Solution
Problem with the connectors between the drive and DeviceNet Option.		Turn the power off and check the connectors between the drive and DeviceNet Option.
Digital Operator Display		Fault Name
\square FA30 to \square FA43	oFA30 to oFA43	DeviceNet Option Fault (CN5-A)
		Communication ID error
Cause		Possible Solution
DeviceNet Option hardware fault		Replace the DeviceNet Option. Contact Yaskawa for assistance.
Operator Display		Fault Name
\square Fb00	oFb00	DeviceNet Option Fault (CN5-B)
		Non-compatible option card is connected.
Cause		Possible Solution
Non-compatible option connected to the drive.		⇒ Connect the correct option card to CN5-A.

Operator Display		Fault Name
oFb02	oFb02	DeviceNet Option Fault (CN5-B)
		Two of the same option cards are connected at the same time.
Cause		Possible Solution
Option cards AI-A3 or DI-A3 were connected to the CN5-B port while an option card was already connected to CN5-A.		⇒ Only one type of option input card AI-A3 or DI-A3 can be connected to the drive. Only this option card for DeviceNet can be connected to CN5-A.
Operator Display		Fault Name
oFc00	oFc00	DeviceNet Option Fault (CN5-C)
		Non-compatible option card is connected.
Cause		Possible Solution
Non-compatible option card connected to the drive.		⇒ Connect the correct option card to CN5-A.
Operator Display		Fault Name
oFc02	oFc02	DeviceNet Option Fault (CN5-C)
		Two of the same option cards are connected at the same time.
Cause		Possible Solution
Option cards AI-A3 or DI-A3 were connected to the CN5-C port while an option card was already connected to CN5-A.		⇒ Only one type of option input card AI-A3 or DI-A3 can be connected to the drive. Only this option card for DeviceNet can be connected to CN5-A.

■ Minor Faults and Alarms

Digital Operator Display		Fault Name	
CALL	CALL	Serial Communication Transmission Error	
		Communication has not yet been established.	
Cause		Possible Solution	Minor Fault (H2-□□ = 10)
Communication wiring or terminal resistor connection is faulty, there is a short circuit, or something is not connected properly.		Check for wiring errors. Correct the wiring. Remove and ground shorts and reconnect loose wires.	Yes
Programming error on the master side		Check communications at start-up and correct programming errors.	
Communication circuitry is damaged.		Perform a self-diagnostics check. Replace the drive if the fault continues to occur.	

8 Configuring DeviceNet Messaging

This section provides information on the various methods used to control the drive on DeviceNet.

◆ Drive Configuration on DeviceNet

■ Polled Configuration

The Drive DeviceNet Polled connection must be configured before receiving commands from a Master device. The two parameters that must be configured are:

- F6-52: Polled Consuming Assembly (PCA)
Note: Output assembly consumed by the drive.
- F6-53: Polled Producing Assembly (PPA)
Note: Input assembly produced by the drive.

The default connection paths for the DeviceNet Option are set for Extended Speed Control.

The PCA and PPA parameters can be accessed by two methods.

- A software configuration tool (not supplied), and Yaskawa Electronic Data Sheet (EDS)
Note: The PCA and PPA parameters can be accessed from the “DN: Polled Config” parameter group.
- A software configuration tool (not supplied), via a DeviceNet message path, such as (Extended Speed Control)
Note: Use DeviceNet Connection Object to change the PCA or PPA if required by the application (Class 5, Instance 1, Attributes 14 and 16)

One each PCA and PPA assembly from the following table must be selected to configure the drive for polled operation.

Table 10 Supported Polled Assemblies (PCA and PPA)

Assembly Number (decimal)	Description	Type	Bytes	Page
20	Basic Speed Control Output - 20 (0x14)	PCA	4	30
21	Extended Speed Control Output - 21 (0x15) (Default Setting)	PCA	4	30
22	Speed and Torque Control Output - 22 (0x16)	PCA	6	–
23	Extended Speed and Torque Control Output - 23 (0x17)	PCA	6	–
70	Basic Speed Control Input - 70 (0x46)	PPA	4	30
71	Extended Speed Control Input - 71 (0x47) (Default Setting)	PPA	4	30
72	Speed and Torque Control Input - 72 (0x48)	PPA	6	–
73	Extended Speed and Torque Control Input - 73 (0x49)	PPA	6	–
100	MEMOBUS/Modbus Message Command (Vendor Specific YE Assy) - 100 (0x64)	PCA	5	–

8 Configuring DeviceNet Messaging

Assembly Number (decimal)	Description	Type	Bytes	Page
101	Standard Control (Vendor Specific YE Assy) - 101 (0x65)	PCA	8	–
102	Accel/Decel Time (Vendor Specific YE Assy) - 102 (0x66)	PCA	8	–
105	Enhanced Speed Control, Dynamic (Vendor Specific YE Assy) - 105 (0x69)	PCA	8	–
106	Enhanced Control (Vendor Specific YE Assy) - 106 (0x6A)	PCA	8	–
107	Standard DI/DO Control (Vendor Specific YE Assy) - 107 (0x6B)	PCA	8	–
108	Enhanced Torque Control, Dynamic (Vendor Specific YE Assy) - 108 (0x6C)	PCA	8	–
120	Speed Command 1 (Vendor Specific YE Assy) - 120 (0x78)	PCA	4	–
121	Torque Command 1 (Vendor Specific YE Assy) - 121 (0x79)	PCA	4	–
122	Speed Command 2 (Vendor Specific YE Assy) - 122 (0x7A)	PCA	6	–
123	Torque Command 2 (Vendor Specific YE Assy) - 123 (0x7B)	PCA	6	–
124	Speed Dynamic Assy (Vendor Specific YE Assy) - 124 (0x7C)	PCA	8	–
125	Torque Dynamic Assy (Vendor Specific YE Assy) - 125 (0x7D)	PCA	8	–
126	Speed/Torque Assy (Vendor Specific YE Assy) - 126 (0x7E)	PCA	8	–
130	Speed Status (Vendor Specific YE Assy) - 130 (0x82)	PPA	4	–
131	Current Status (Vendor Specific YE Assy) - 131 (0x83)	PPA	4	–
132	Current & Speed Status (Vendor Specific YE Assy) - 132 (0x84)	PPA	6	–
134	Speed Status Dynamic Assy (Vendor Specific YE Assy) - 134 (0x86)	PPA	8	–
135	Current Status Dynamic Assy (Vendor Specific YE Assy) - 135 (0x87)	PPA	8	–
136	Torque and Speed Status (Vendor Specific YE Assy) - 136 (0x88)	PPA	8	–
150	MEMOBUS/Modbus Message Reply (Vendor Specific YE Assy) - 150 (0x96)	PPA	5	–
151	Standard Status 1 (Vendor Specific YE Assy) - 151 (0x97)	PPA	8	–
152	Standard Status 2 (Vendor Specific YE Assy) - 152 (0x98)	PPA	8	–
155	Enhanced Speed Status, Dynamic (Vendor Specific YE Assy) - 155 (0x9B)	PPA	8	–
156	Enhanced Control Status (Vendor Specific YE Assy) - 156 (0x9C)	PPA	8	–
157	Standard DI/DO Status (Vendor Specific YE Assy) - 157 (0x9D)	PPA	8	–
158	Enhanced Torque Status, Dynamic (Vendor Specific YE Assy) - 158 (0x9E)	PPA	8	–
199	Change of State Response (Vendor Specific YE Assy) - 199 (0xC7)	PPA	8	–

◆ Drive Operation on DeviceNet

■ Polled Assemblies Quick Reference

Refer to the DeviceNet Option SI-N3 Technical Manual for details on polled assemblies and other message types.

8 Configuring DeviceNet Messaging

Output Assemblies/Drive Consumes

Instance	Byte	Bit 7	Bit 6	Bit 5	Bit 4	Bit 3	Bit 2	Bit 1	Bit 0
20 DeviceNet Basic Speed Control	0	-	-	-	-	-	Fault Reset	-	Run Fwd
	1	-							
	2	Speed Reference (Low Byte)							
	3	Speed Reference (High Byte)							

Instance	Byte	Bit 7	Bit 6	Bit 5	Bit 4	Bit 3	Bit 2	Bit 1	Bit 0
21 DeviceNet Extended Speed Control	0	-	Net Ref	Net Ctrl	-	-	Fault Reset	Run Rev	Run Fwd
	1	-							
	2	Speed Reference (Low Byte)							
	3	Speed Reference (High Byte)							

Input Assemblies/Drive Produces

Instance	Byte	Bit 7	Bit 6	Bit 5	Bit 4	Bit 3	Bit 2	Bit 1	Bit 0
70 DeviceNet Basic Speed Control	0	-	-	-	-	-	Running 1 (FWD)	-	Faulted
	1	-							
	2	Speed Actual (Low Byte)							
	3	Speed Actual (High Byte)							

Instance	Byte	Bit 7	Bit 6	Bit 5	Bit 4	Bit 3	Bit 2	Bit 1	Bit 0
71 DeviceNet Extended Speed Control	0	At Speed	Ref from Net	Ctrl from Net	Ready	Running 2 (REV)	Running 1 (FWD)	Warning	Faulted
	1	State							
	2	Speed Actual (Low Byte)							
	3	Speed Actual (High Byte)							

9 Specifications

◆ Specifications

Table 11 Option Specifications

Items	Specifications
Model	SI-N3
SI-N3 Supported Messages	Group 2 Server (UCMM capable) Explicit Messages: Fragmentation is supported. Up to 32 bytes can be input and output. Polled I/O Messages: Fragmentation is not supported. Up to 8 bytes can be input and output. Faulted Node Recovery / Offline Connection Set Messages / Automatic Device Replacement (ADR) Change of State Message (COS). COS can be used as an I/O Input Assembly.
I/O Assembly Instance	Input: 17 types (4~8 bytes) Output: 18 types (4~8 bytes)
DeviceNet Specification	Conformance Level 19: Passed
DeviceNet Profile	AC Drive
Input Power	Voltage: 11~25 Vdc Current: 40 mA
Connector Type	5-pin open-style screw connector
Physical Layer Type	Isolated Physical Layer CAN transceiver + photocoupler
MAC ID Setting	Programmable from drive keypad or network: MAC ID 0 to 63
Communications Speed/Baud Rate	Programmable from drive keypad or network: 125/250/500 k bit/s Auto Baud Rate Idle Mode Detect Heartbeat
Ambient Temperature	-10 °C to +50 °C
Humidity	up to 95% RH (no condensation)
Storage Temperature	-20 °C to +60 °C (allowed for short-term transport of the product)
Area of Use	Indoor (free of corrosive gas, airborne particles, etc.)
Altitude	up to 1000 m

9 Specifications

◆ Revision History

The revision dates and the numbers of the revised manuals appear on the bottom of the back cover.

MANUAL NO. TOBP C730600 43A

Published in Japan July 2008 08-7

└─ Date of
publication ─┬─ Date of original
publication

Date of Publication	Revision Number	Section	Revised Content
July 2008	–	–	First edition

YASKAWA AC Drive-Option Card

DeviceNet Installation Manual

IRUMA BUSINESS CENTER (SOLUTION CENTER)

480, Kamifuji-sawa, Iruma, Saitama 358-8555, Japan
Phone 81-4-2962-5696 Fax 81-4-2962-6138

YASKAWA ELECTRIC AMERICA, INC.

2121 Norman Drive South, Waukegan, IL 60085, U.S.A.
Phone 1-847-887-7000 Fax 1-847-887-7370

YASKAWA ELÉTRICO DO BRASIL LTDA.

Avenida Fagundes Filho, 620 São Paulo-SP CEP 04304-000, Brazil
Phone 55-11-3585-1100 Fax 55-11-5581-8795

YASKAWA ELECTRIC EUROPE GmbH

Hauptstraße 185, 65760 Eschborn, Germany
Phone 49-6196-569-300 Fax 49-6196-569-398

YASKAWA ELECTRIC UK LTD.

1 Hunt Hill Orchardton Woods Cumbernauld, G68 9LF, United Kingdom
Phone 44-1236-735000 Fax 44-1236-458182

YASKAWA ELECTRIC KOREA CORPORATION

7F, Doore Bldg. 24, Yeoido-dong, Youngdungpo-Ku, Seoul 150-877, Korea
Phone 82-2-784-7844 Fax 82-2-784-8495

YASKAWA ELECTRIC (SINGAPORE) PTE. LTD.

151 Lorong Chuan, #04-01, New Tech Park 556741, Singapore
Phone 65-6282-3003 Fax 65-6289-3003

YASKAWA ELECTRIC (SHANGHAI) CO., LTD.

No.18 Xizang Zhong Road, Room 1702-1707, Harbour Ring Plaza Shanghai 200001, China
Phone 86-21-5385-2200 Fax 86-21-5385-3299

YASKAWA ELECTRIC (SHANGHAI) CO., LTD. BEIJING OFFICE

Room 1011A, Tower W3 Oriental Plaza, No.1 East Chang An Ave.,
Dong Cheng District, Beijing 100738, China
Phone 86-10-8518-4086 Fax 86-10-8518-4082

YASKAWA ELECTRIC TAIWAN CORPORATION

9F, 16, Nanking E. Rd., Sec. 3, Taipei, Taiwan
Phone 886-2-2502-5003 Fax 886-2-2505-1280



YASKAWA

YASKAWA ELECTRIC CORPORATION

In the event that the end user of this product is to be the military and said product is to be employed in any weapons systems or the manufacture thereof, the export will fall under the relevant regulations as stipulated in the Foreign Exchange and Foreign Trade Regulations. Therefore, be sure to follow all procedures and submit all relevant documentation according to any and all rules, regulations and laws that may apply. Specifications are subject to change without notice for ongoing product modifications and improvements.

© 2008 YASKAWA ELECTRIC CORPORATION. All rights reserved.

MANUAL NO. TOBP C730600 3A4

Published in Japan July 2008 08-7
08-5-3